

\sqrt{N} 54/74157 011147
 \sqrt{N} 54S/74S157 011151
 \sqrt{N} 54LS/74LS157 011150
QUAD 2-INPUT MULTIPLEXER

**CONNECTION DIAGRAM
PINOUT A**

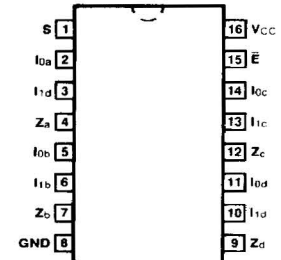

DESCRIPTION — The '157 is a high speed quad 2-input multiplexer. Four bits of data from two sources can be selected using the common Select and Enable inputs. The four buffered outputs present the selected data in the true (non-inverted) form. The '157 can also be used to generate any four of the 16 different functions to two variables.

ORDERING CODE: See Section 9

PKGS	PIN OUT	COMMERCIAL GRADE	MILITARY GRADE	PKG TYPE
		V _{CC} = +5.0 V ±5%, T _A = 0°C to +70°C	V _{CC} = +5.0 V ±10%, T _A = -55°C to +125°C	
Plastic DIP (P)	A	74157PC, 74S157PC 74LS157PC		9B
Ceramic DIP (D)	A	74157DC, 74S157DC 74LS157DC	54157DM, 54S157DM 54LS157DM	6B
Flatpak (F)	A	74157FC, 74S157FC 74LS157FC	54157FM, 54S157FM 54LS157FM	4L

LOGIC SYMBOL

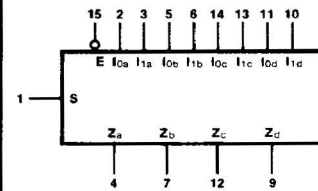

V_{CC} = Pin 16
GND = Pin 8

INPUT LOADING/FAN-OUT: See Section 3 for U.L. definitions

PIN NAMES	DESCRIPTION	54/74 (U.L.) HIGH/LOW	54/74S (U.L.) HIGH/LOW	54/74LS (U.L.) HIGH/LOW
I _{0a} — I _{0d}	Source 0 Data Inputs	1.0/1.0	1.25/1.25	0.5/0.25
I _{1a} — I _{1d}	Source 1 Data Inputs	1.0/1.0	1.25/1.25	0.5/0.25
\bar{E}	Enable Input (Active LOW)	1.0/1.0	2.5/2.5	1.0/0.5
S	Select Input	1.0/1.0	2.5/2.5	1.0/0.5
Z _a — Z _d	Outputs	20/10	25/12.5	10/5.0 (2.5)

FUNCTIONAL DESCRIPTION — The '157 is a quad 2-input multiplexer. It selects four bits of data from two sources under the control of a common Select input (S). The Enable input (\bar{E}) is active LOW. When \bar{E} is HIGH, all of the outputs (Z) are forced LOW regardless of all other inputs. The '157 is the logic implementation of a 4-pole, 2-position switch where the position of the switch is determined by the logic levels supplied to the Select input. The logic equations for the outputs are shown below:

$$Z_a = \bar{E} \cdot (I_{1a} \cdot S + I_{0a} \cdot \bar{S}) \quad Z_b = \bar{E} \cdot (I_{1b} \cdot S + I_{0b} \cdot \bar{S})$$

$$Z_c = \bar{E} \cdot (I_{1c} \cdot S + I_{0c} \cdot \bar{S}) \quad Z_d = \bar{E} \cdot (I_{1d} \cdot S + I_{0d} \cdot \bar{S})$$

A common use of the '157 is the moving of data from two groups of registers to four common output busses. The particular register from which the data comes is determined by the state of the Select input. A less obvious use is as a function generator. The '157 can generate any four of the 16 different functions of two variables with one variable common. This is useful for implementing highly irregular logic.

LOGIC DIAGRAMS
'157

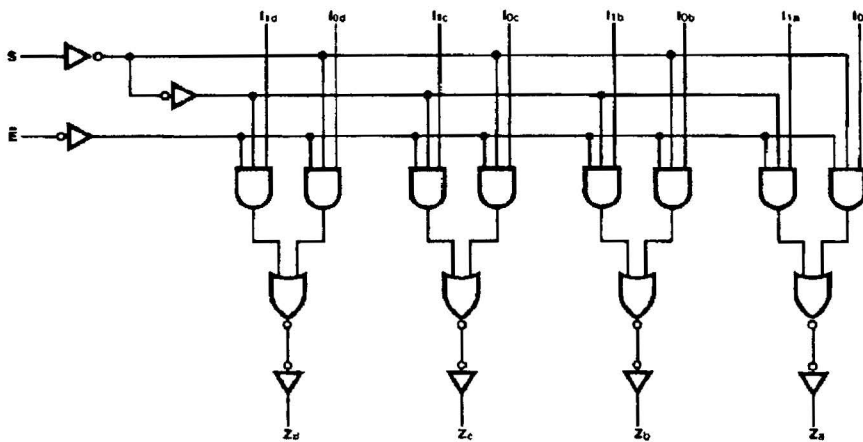

'S157 • 'LS157

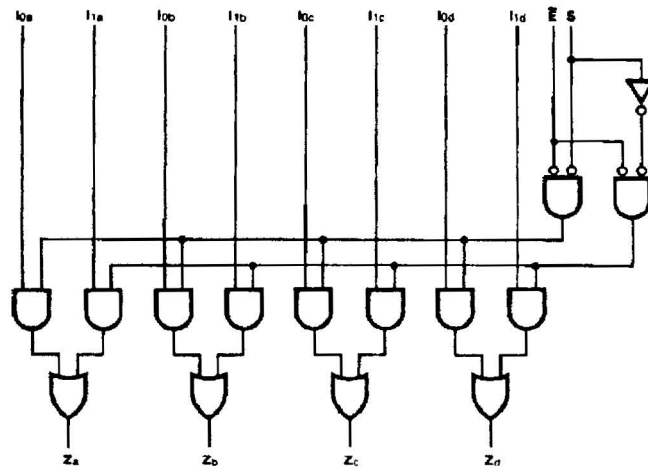

TRUTH TABLE

INPUTS				OUTPUT
\bar{E}	S	I_0	I_1	Z
H	X	X	X	L
L	H	X	L	L
L	H	X	H	H
L	L	L	X	L
L	L	H	X	H

H = HIGH Voltage Level
L = LOW Voltage Level
X = Immaterial

DC CHARACTERISTICS OVER OPERATING TEMPERATURE RANGE (unless otherwise specified)

SYMBOL	PARAMETER		54/74		54/74S		54/74LS		UNITS	CONDITIONS
			Min	Max	Min	Max	Min	Max		
I _{OS}	Output Short Circuit Current	XM	-20	-55	-40	-100	-20	-100	mA	V _{CC} = Max
		XC	-18	-55	-40	-100	-20	-100		
I _{CC}	Power Supply Current		48		78		16		mA	V _{CC} = Max All Inputs = 4.5 V

AC CHARACTERISTICS: V_{CC} = +5.0 V, T_A = +25°C (See Section 3 for waveforms and load configurations)

SYMBOL	PARAMETER	54/74		54/74S		54/74LS		UNITS	CONDITIONS
		C _L = 15 pF R _L = 400 Ω		C _L = 15 pF R _L = 280 Ω		C _L = 15 pF			
		Min	Max	Min	Max	Min	Max		
t _{PLH} t _{PHL}	Propagation Delay S to Z _n	23 27		15 15		26 24		ns	Figs. 3-1, 3-20
t _{PLH} t _{PHL}	Propagation Delay \bar{E} to Z _n	20 21		12.5 12		20 21		ns	Figs. 3-1, 3-4
t _{PLH} t _{PHL}	Propagation Delay I _n to Z _n	14 14		7.5 6.5		14 14		ns	Figs. 3-1, 3-5