

ZY1, ZY11 THRU ZY200

ZENER DIODES

DO-41 Plastic

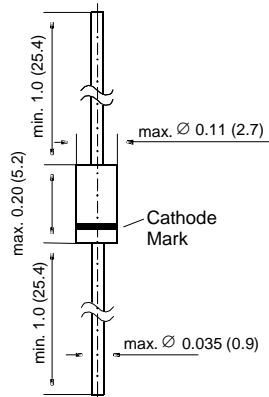

Dimensions are in inches and (millimeters)

FEATURES

- ◆ Silicon Power Zener Diodes
- ◆ For use in stabilizing and clipping circuits with high power rating
- ◆ The Zener voltages are graded according to the international E 24 standard. Smaller voltage tolerances are available upon request.

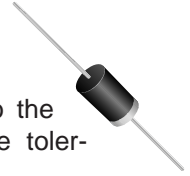

MECHANICAL DATA

Case: DO-41 Plastic Case

Weight: approx. 0.34 g

MAXIMUM RATINGS

Ratings at 25°C ambient temperature unless otherwise specified.

	SYMBOL	VALUE	UNIT
Zener Current (see Table "Characteristics")			
Power Dissipation at $T_{amb} = 25^{\circ}\text{C}$	P_{tot}	2.0 ¹⁾	Watts
Junction Temperature	T_j	150	°C
Storage Temperature Range	T_s	- 55 to +150	°C

	SYMBOL	MIN.	TYP.	MAX.	UNIT
Thermal Resistance Junction to Ambient Air	R_{thJA}	-	-	60 ¹⁾	°C/W

NOTES:

(1) Valid provided that leads are kept at ambient temperature at a distance of 10 mm from case.

ZY1, ZY11 THRU ZY200

ELECTRICAL CHARACTERISTICS

Ratings at 25°C ambient temperature unless otherwise specified.

Type	Zener voltage ⁽²⁾ at I _{ZT} V _Z (V)	Dynamic resistance at I _{ZT} f = 1 kHz max r _{zj} (Ω)	Temp. coeff. of Zener volt. at I _{ZT} α _{VZ} (10 ⁻⁴ /K)	Test current I _{ZT} (mA)	Reverse voltage at I _R = 0.5μA V _R (V)	Admissible Zener current ⁽¹⁾ at T _{amb} = 25°C I _Z (mA)
ZY1 ⁽³⁾	0.71 ... 0.82	0.5 (< 1)	-26 ... -16	100	–	1000
ZY11	10.4 ... 11.6	4 (< 7)	+5 ... +10	50	> 9.2	135
ZY12	11.4 ... 12.7	4 (< 7)	+5 ... +10	50	> 10	120
ZY13	12.4 ... 14.1	5 (< 10)	+5 ... +10	50	> 10.7	110
ZY15	13.8 ... 15.8	5 (< 10)	+5 ... +10	50	> 12	98
ZY16	15.3 ... 17.1	6 (< 15)	+6 ... +11	25	> 13.3	90
ZY18	16.8 ... 19.1	6 (< 15)	+6 ... +11	25	> 14.7	80
ZY20	18.8 ... 21.2	6 (< 15)	+6 ... +11	25	> 16.5	72
ZY22	20.8 ... 23.3	6 (< 15)	+6 ... +11	25	> 18.3	66
ZY24	22.8 ... 25.6	7 (< 15)	+6 ... +11	25	> 20.1	60
ZY27	25.1 ... 28.9	7 (< 15)	+6 ... +11	25	> 22.5	53
ZY30	28 ... 32	8 (< 15)	+6 ... +11	25	> 25.1	48
ZY33	31 ... 35	8 (< 15)	+6 ... +11	25	> 27.8	44
ZY36	34 ... 38	21 (< 40)	+6 ... +11	10	> 30.2	40
ZY39	37 ... 41	21 (< 40)	+6 ... +11	10	> 32.9	37
ZY43	40 ... 46	24 (< 45)	+7 ... +12	10	> 35.6	33
ZY47	44 ... 50	24 (< 45)	+7 ... +12	10	> 39.2	30
ZY51	48 ... 54	25 (< 60)	+7 ... +12	10	> 42.8	27
ZY56	52 ... 60	25 (< 60)	+7 ... +12	10	> 47.3	25
ZY62	58 ... 66	25 (< 80)	+8 ... +13	10	> 51.7	21
ZY68	64 ... 72	25 (< 80)	+8 ... +13	10	> 57.1	20
ZY75	70 ... 79	30 (< 100)	+8 ... +13	10	> 63.2	18
ZY82	77 ... 88	30 (< 100)	+8 ... +13	10	> 68.6	16
ZY91	85 ... 96	60 (< 200)	+9 ... +13	5	> 75.7	15
ZY100	94 ... 106	60 (< 200)	+9 ... +13	5	> 83.7	13
ZY110	104 ... 116	80 (< 250)	+9 ... +13	5	> 92.6	12
ZY120	114 ... 127	80 (< 250)	+9 ... +13	5	> 101.6	11
ZY130	124 ... 141	110 (< 300)	+9 ... +13	5	> 110.5	10
ZY150	138 ... 156	110 (< 300)	+9 ... +13	5	> 123	9
ZY160	153 ... 171	150 (< 350)	+9 ... +13	5	> 136	8.5
ZY180	168 ... 191	150 (< 350)	+9 ... +13	5	> 149	8
ZY200	188 ... 212	150 (< 350)	+9 ... +13	5	> 167	7.5

NOTES:

(1) Valid provided that leads are kept at ambient temperature at a distance of 10 mm from case

(2) Tested with pulses t_p = 5 ms

(3) The ZY1 is a silicon diode operated in forward direction. Hence, the index of all parameters ratings should be "F" instead of "Z". Connect the cathode lead to the negative pole

RATINGS AND CHARACTERISTIC CURVES ZY1, ZY11 THRU ZY200

Breakdown characteristics

$T_j = \text{constant (pulsed)}$

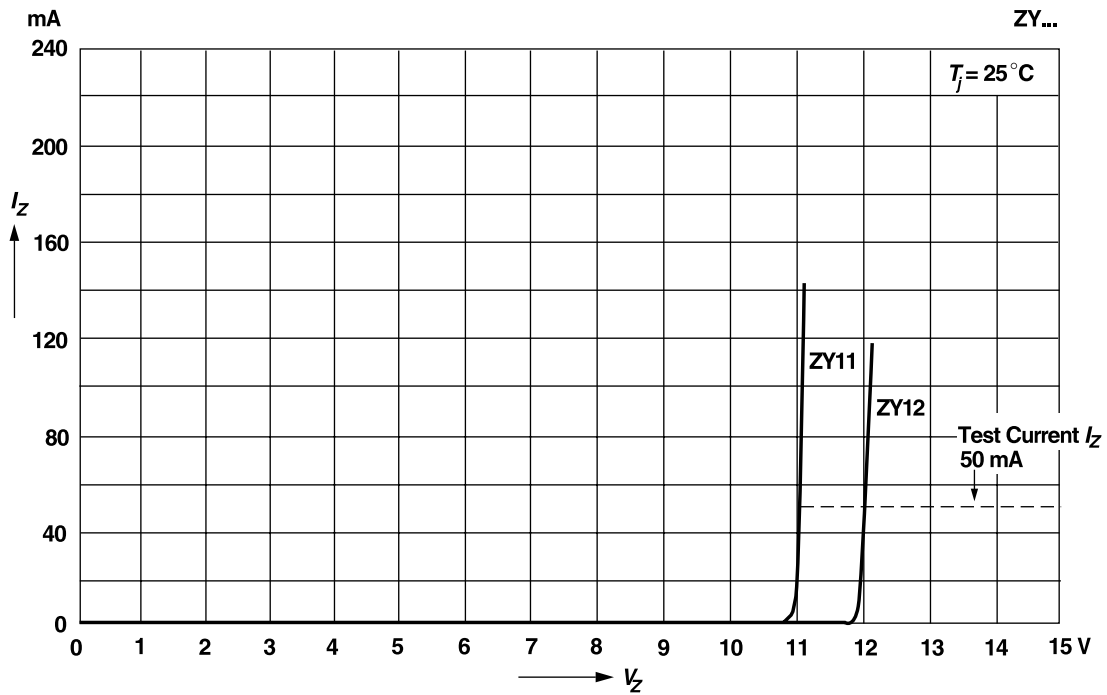

Breakdown characteristics

$T_j = \text{constant (pulsed)}$

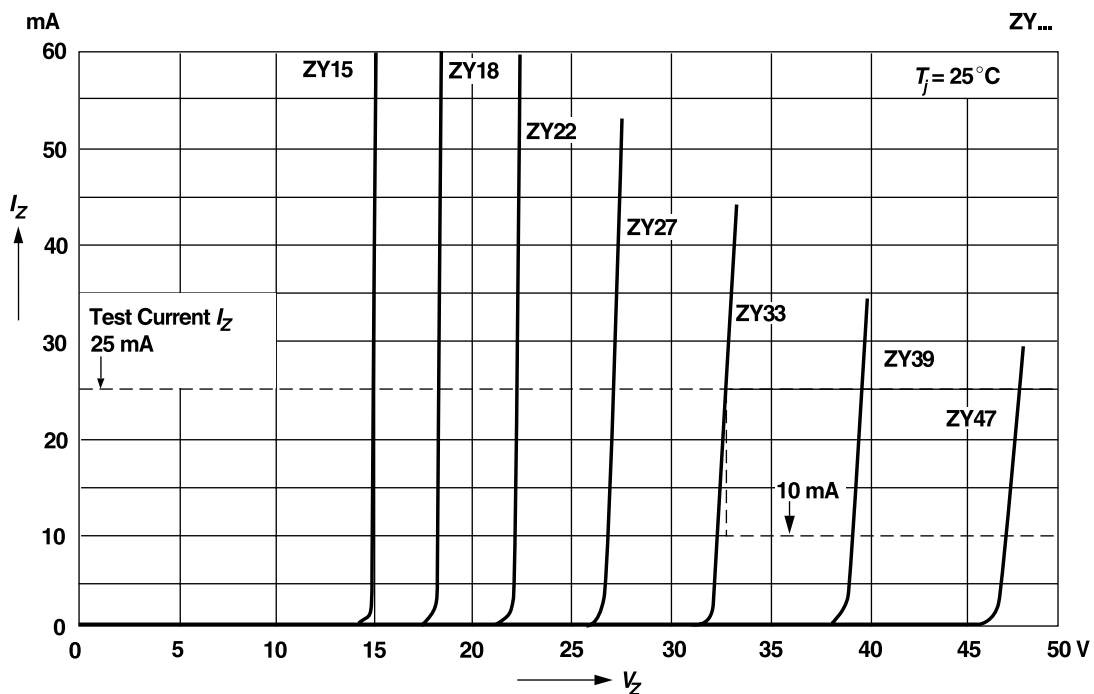

RATINGS AND CHARACTERISTIC CURVES ZY1, ZY11 THRU ZY200

Breakdown characteristics

$T_j = \text{constant (pulsed)}$

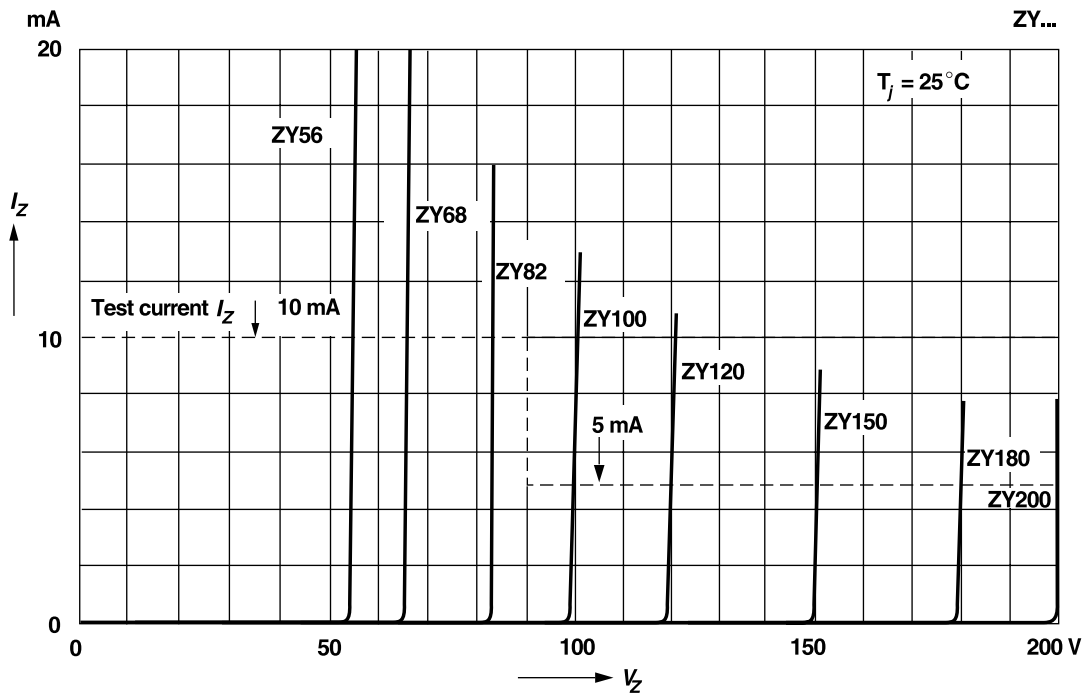

Admissible power dissipation versus ambient temperature

Valid provided that leads are kept at ambient temperature at a distance of 10 mm from case

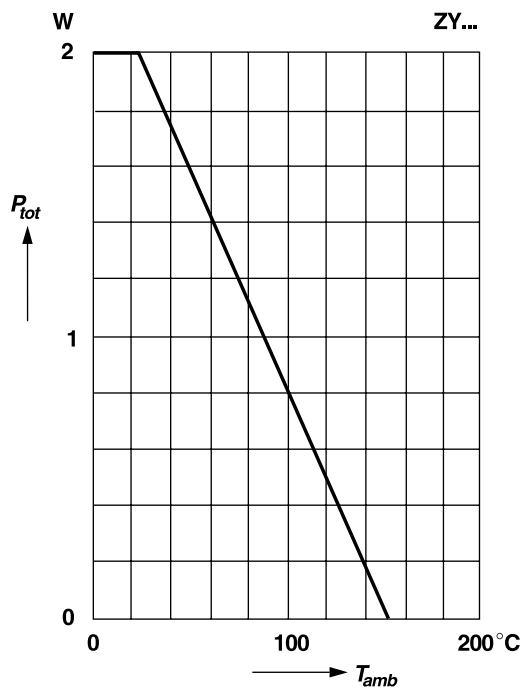

Dynamic resistance versus Zener current

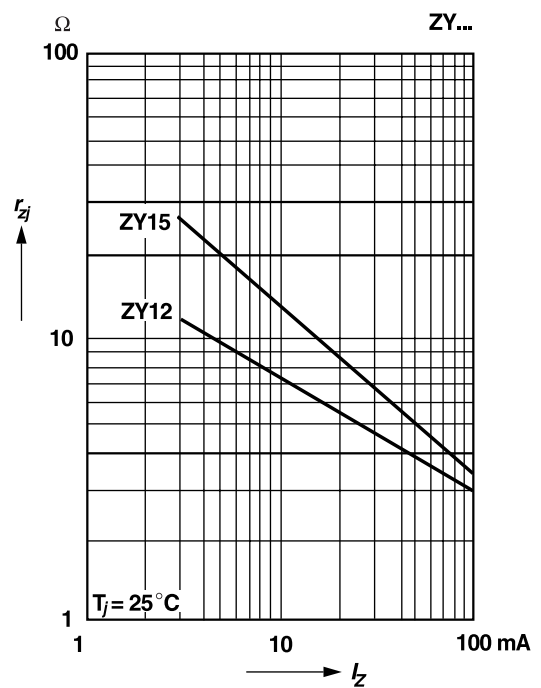

RATINGS AND CHARACTERISTIC CURVES ZY1, ZY11 THRU ZY200

Dynamic resistance versus Zener current

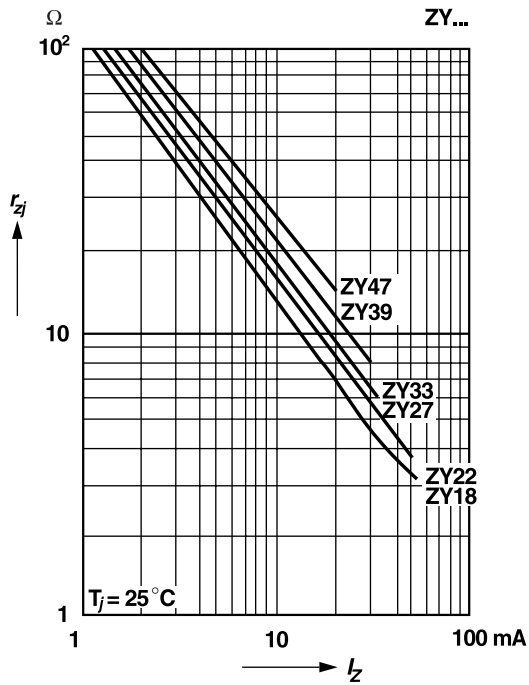

Thermal differential resistance versus Zener voltage

Valid provided that leads are kept at ambient temperature at a distance of 10 mm from case

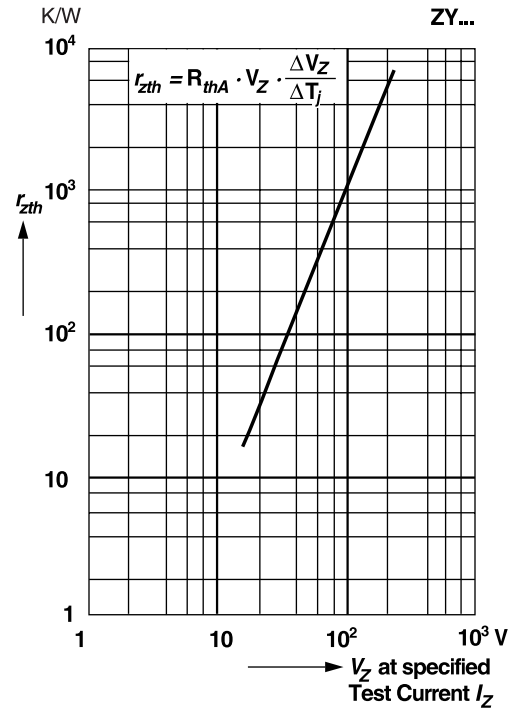

Dynamic resistance versus Zener current

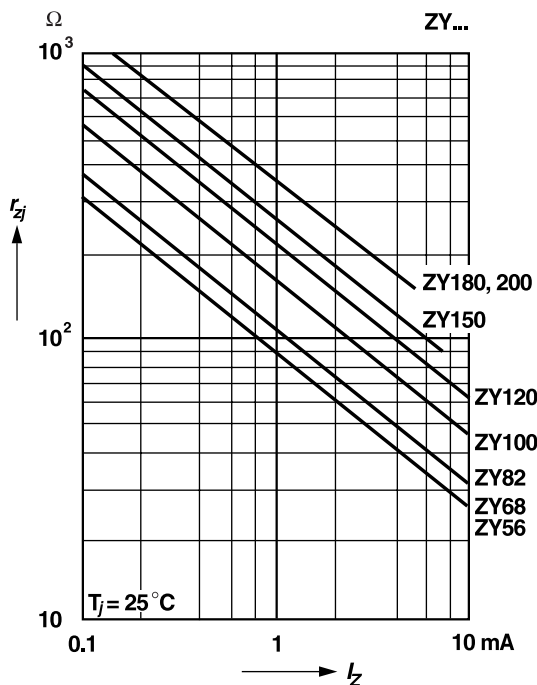

Change of Zener voltage from turn-on up to the point of thermal equilibrium versus Zener Voltage

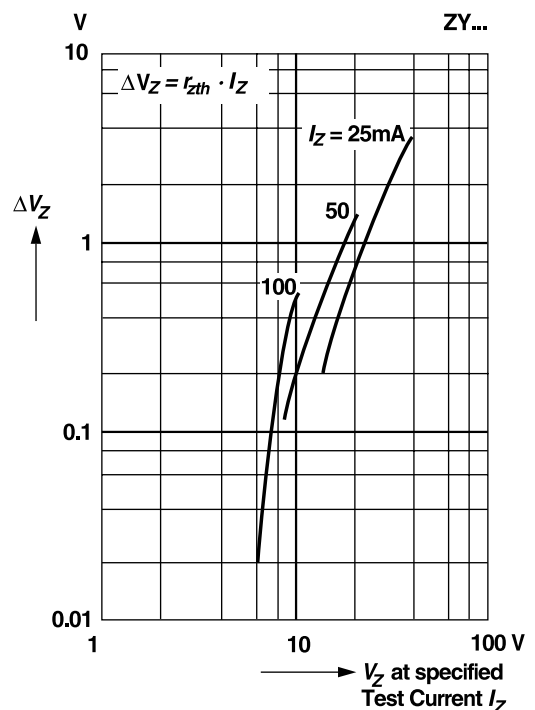

RATINGS AND CHARACTERISTIC CURVES ZY1, ZY11 THRU ZY200

Relative change of Zener voltage versus turn-on time

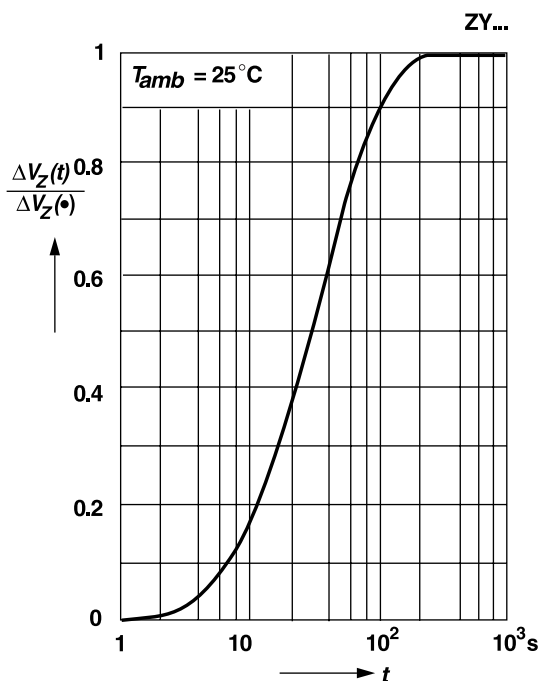

Thermal resistance versus lead length

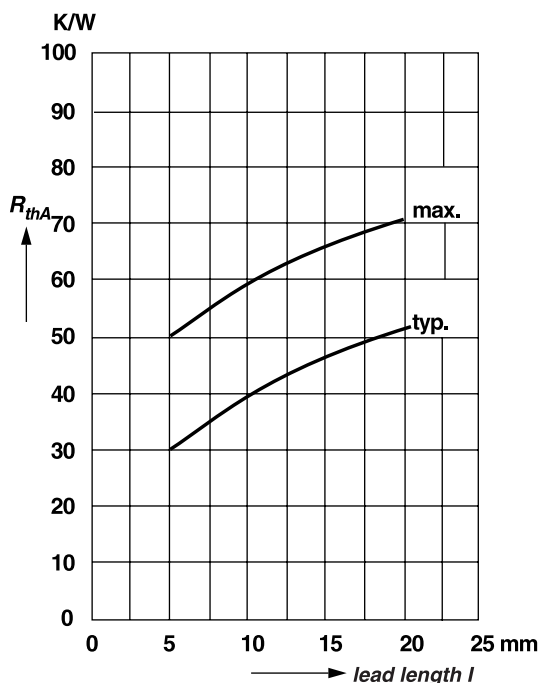

Pulse thermal resistance versus pulse duration

Valid provided that leads are kept at ambient temperature at a distance of 10 mm from case

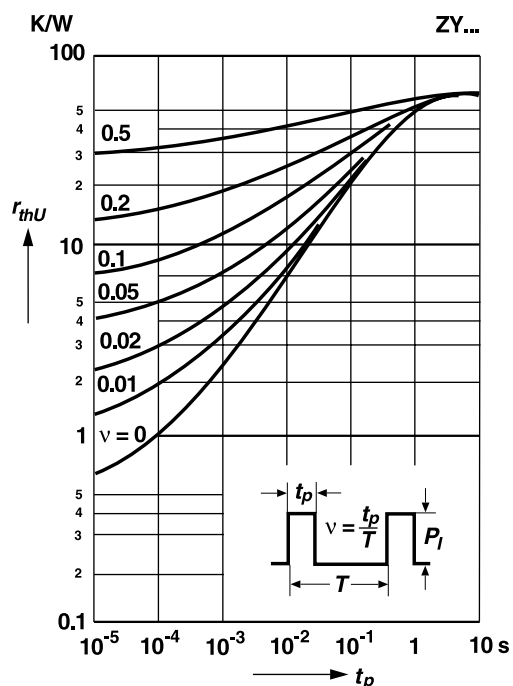

RATINGS AND CHARACTERISTIC CURVES ZY1, ZY11 THRU ZY200

Difference between Zener voltage at test current pulses less than 1 s duration and Zener voltage at the point of thermal equilibrium versus Zener current

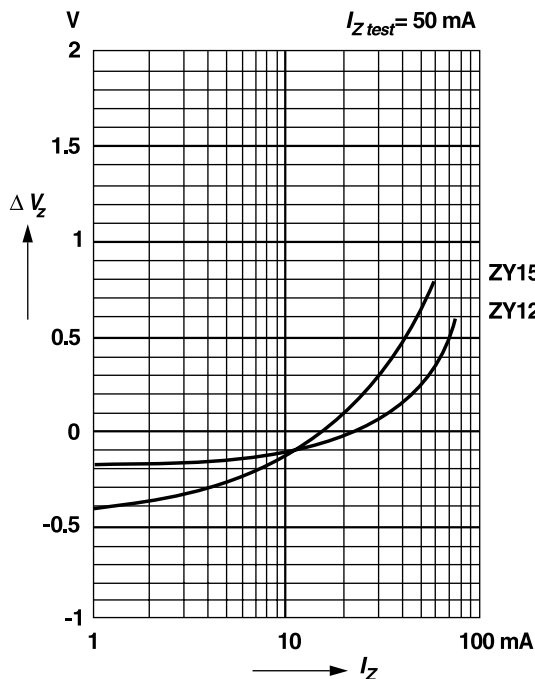

Difference between Zener voltage at test current pulses less than 1 s duration and Zener voltage at the point of thermal equilibrium versus Zener current

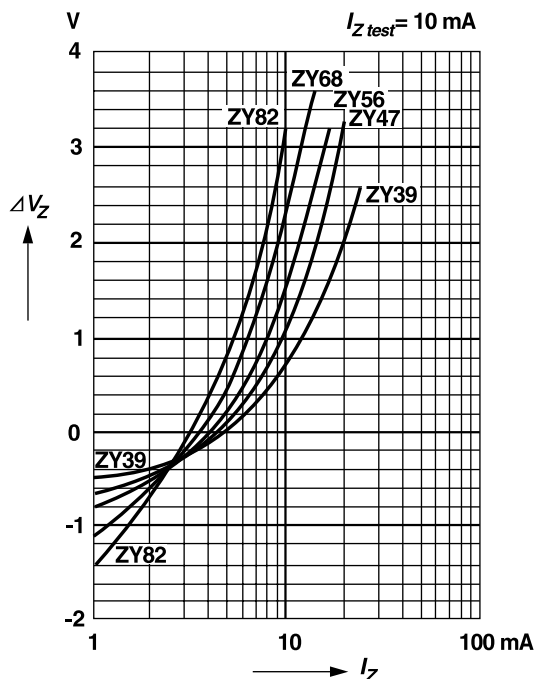

Difference between Zener voltage at test current pulses less than 1 s duration and Zener voltage at the point of thermal equilibrium versus Zener current

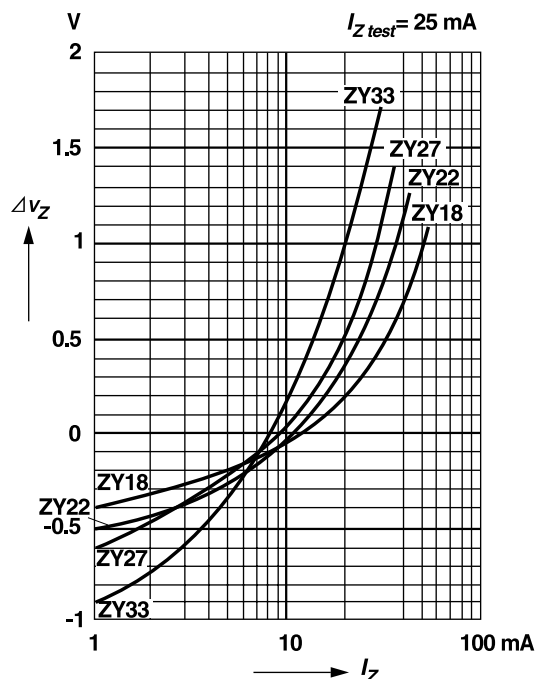

Difference between Zener voltage at test current pulses less than 1 s duration and Zener voltage at the point of thermal equilibrium versus Zener current

