

XJ Type

12.5 x 4.5 mm Crystal

FEATURE

- Typical 12.5 x 4.5 x 4.0 mm metal can SMD package..
- 24mm width Tape & Reel package for automatic assembly.
- Packing: Tape & Reel ,standard 1000 pcs per Reel.

TYPICAL APPLICATION

- Automotive
- Bluetooth, Wireless
- Computers, Modems, Communications
- Set-top Box, DECT/WDCT



RoHS Compliant Standard

DIMENSION (mm)

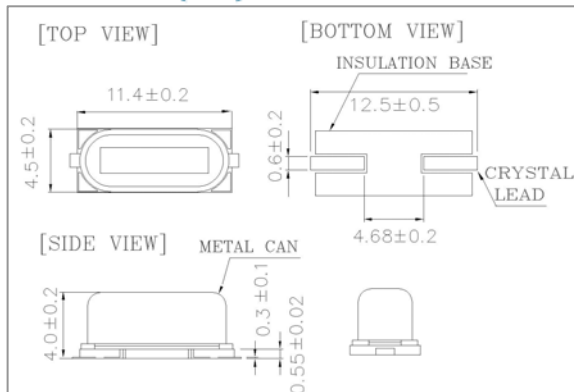

SOLDER PAD LAYOUT (mm)

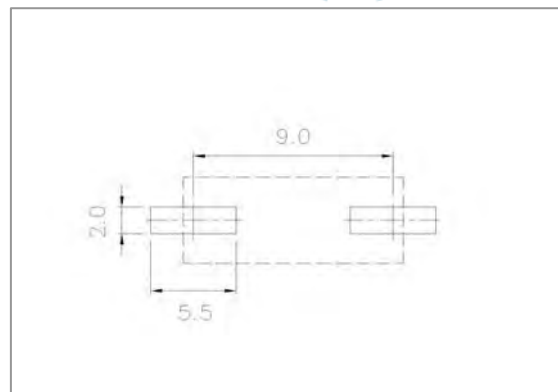

ELECTRICAL SPECIFICATION

Parameter	Min.	Typical	Max.	Unit
Storage Temp. Range	-55	-	125	°C
Level of Drive	-	10	800	µw
Shunt Capacitance (C ₀)	-	-	7.0	pF
Insulation Resistance	500 MΩ @ DC100V	-	-	-
Aging (@ 25°C, 1st year)	-	±5	-	ppm / year

Standard frequencies are frequencies which the crystal has been designed and does not imply a stock position.
 Packing: Tape & Reel, standard 1000 pcs per Reel.

EQUIVALENT SERIES RESISTANCE (E.S.R)

TYPE FREQUENCY	MODE	E.S.R
Freq. ≤ 4 MHz	A1	<140 Ω
4 MHz < Freq. < 5 MHz	A1	<120 Ω
5 MHz ≤ Freq. < 7 MHz	A1	<80 Ω
7 MHz ≤ Freq. < 9 MHz	A1	<45 Ω
9 MHz ≤ Freq. < 13 MHz	A1	<40 Ω
13 MHz ≤ Freq. < 16 MHz	A1	<35 Ω
16 MHz ≤ Freq. < 20 MHz	A1	<30 Ω
20 MHz ≤ Freq. < 30 MHz	A1	<25 Ω
30 MHz ≤ Freq. < 36 MHz	A1	<25 Ω
30 MHz ≤ Freq. < 36 MHz	A3	<80 Ω
36 MHz ≤ Freq. < 80 MHz	A3	<80 Ω

FREQ. STABILITY vs. LOAD CAPACITANCE

Load Capacitance	ppm	±5	±10	±15	±20	±30
8pF		X	X	△	○	○
10pF		X	X	△	○	○
12pF		X	△	○	○	○
16pF		X	△	○	○	○
Series		△	○	○	○	○

* ○: Available △:Conditional X: Not available

FREQ. STABILITY vs. TEMP. RANGE

Temp.(°C)	ppm	±5	±10	±15	±20
-10 ~ +60		X	○	○	○
-20 ~ +70		X	△	○	○
-40 ~ +85		X	X	X	○

* ○: Available △:Conditional X: Not available