

18-Line Low Capacitance SCSI Active Terminator

FEATURES

- Reverse Disconnect
- Complies with SCSI, SCSI-2 and SPI-2 Standards
- 6pF Channel Capacitance during Disconnect
- 100µA Supply Current in Disconnect Mode
- Meets SCSI Hot Plugging Capability
- -650mA Sourcing Current for Termination
- +200mA Sinking Current for Active Negation
- Provides Active Termination for 18 Lines
- Logic Command Disconnects all Termination Lines
- Trimmed Termination Current to 5%
- Trimmed Impedance to 5%
- Current Limit and Thermal Shutdown Protection

DESCRIPTION

The UC5609 provides 18 lines of active termination for a SCSI (Small Computer Systems Interface) parallel bus. The SCSI standard recommends active termination at both ends of the bus cable.

The UC5609 is pin-for-pin compatible with its predecessors, the UC5601, UC5602 and UC5608 - 18 Line Active Terminators, except for the reverse disconnect sense. Parametrically the UC5609 has a 5% tolerance on impedance and current compared to a 3% tolerance on the UC5601 and the sink current is increased from 20 to 200mA. The low side clamps have been removed. Custom power packages are utilized to allow normal operation at full power conditions (2 Watts).

When in disconnect mode the terminator will disconnect all terminating resistors and disable the regulator, greatly reducing standby power. The output channels remain high impedance even without Tempwr applied.

Internal circuit trimming is utilized to trim the impedance to a 5% tolerance and, most importantly, to trim the output current to a 5% tolerance, as close to the max SCSI spec as possible, which maximizes noise margin in fast SCSI operation.

Other features include 4.0 to 5.25V Tempwr, thermal shutdown and current limit.

This device is offered in low thermal resistance versions of the industry standard 28 pin wide body SOIC, 28 pin wide body TSSOP, and 28 pin PLCC, as well as 24 pin DIP.

BLOCK DIAGRAM

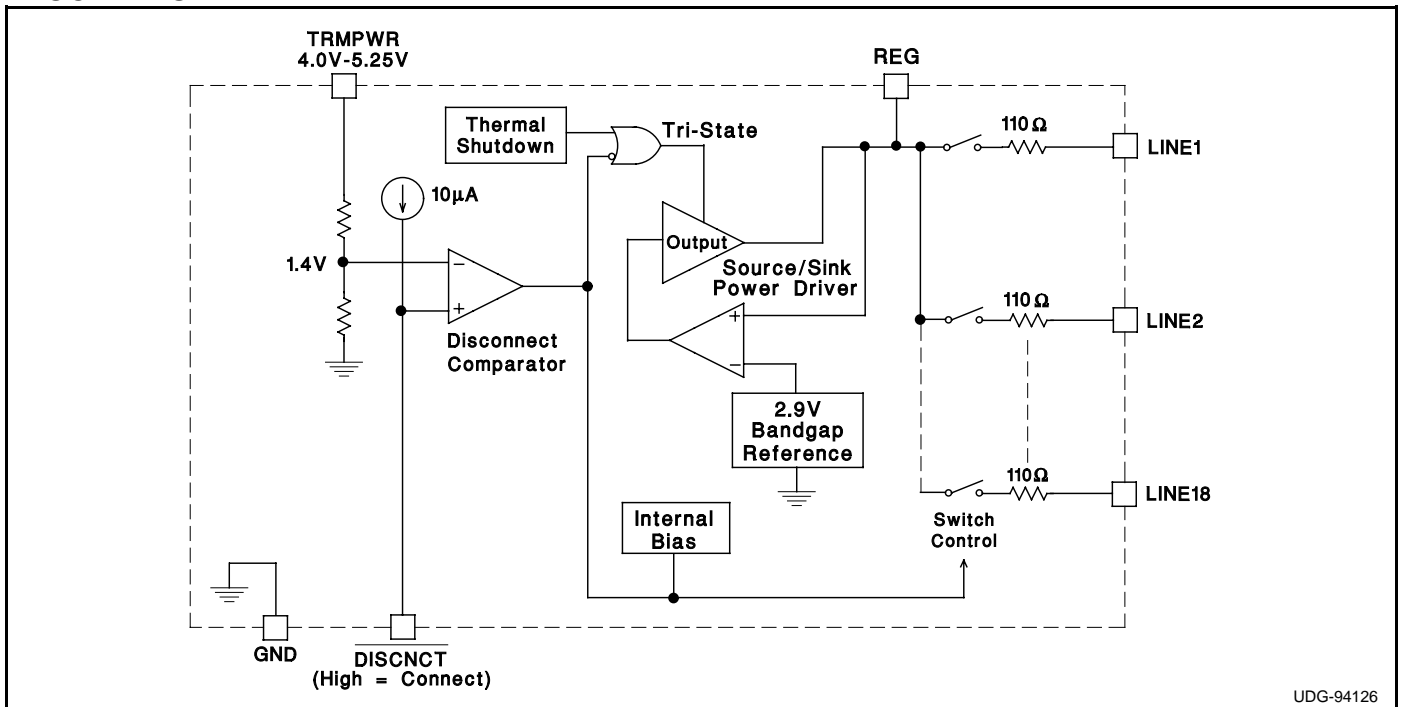

UDG-94126

Circuit Design Patented

ABSOLUTE MAXIMUM RATINGS

Tempwr Voltage	+7V
Signal Line Voltage	0V to +7V
Regulator Output Current	1A
Storage Temperature	-65°C to +150°C
Operating Temperature	-55°C to +150°C
Lead Temperature (Soldering, 10 Sec.)	+300°C

Unless otherwise specified all voltages are with respect to Ground. Currents are positive into, negative out of the specified terminal.

Consult Packaging Section of Unitrode Integrated Circuits databook for thermal limitations and considerations of packages.

RECOMMENDED OPERATING CONDITIONS

Tempwr Voltage	3.8V to 5.25V
Signal Line Voltage	0V to +5V
Disconnect Input Voltage	0V to Tempwr

CONNECTION DIAGRAMS

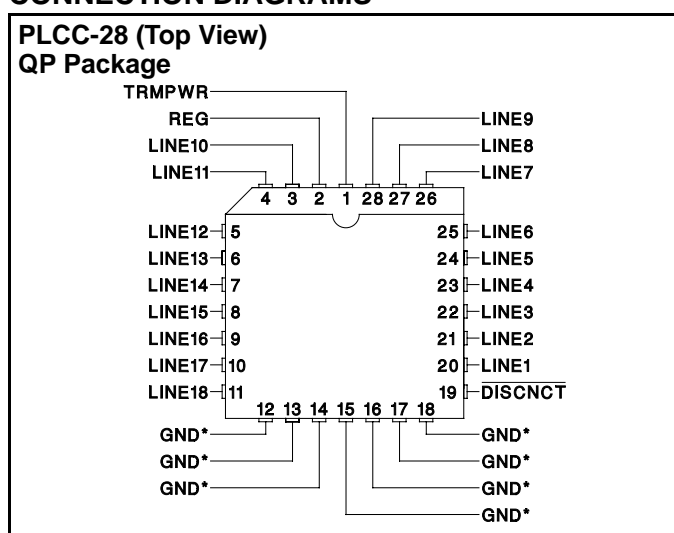

* QP package pins 12 - 18 serve as both heatsink and signal ground.

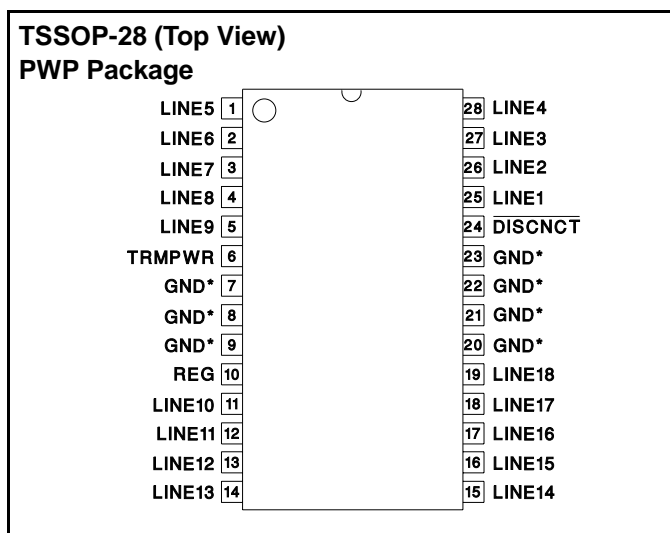

* PWP package pin 23 serves as signal ground; pins 7, 8, 9, 20, 21 and 22 serve as heatsink/ground.

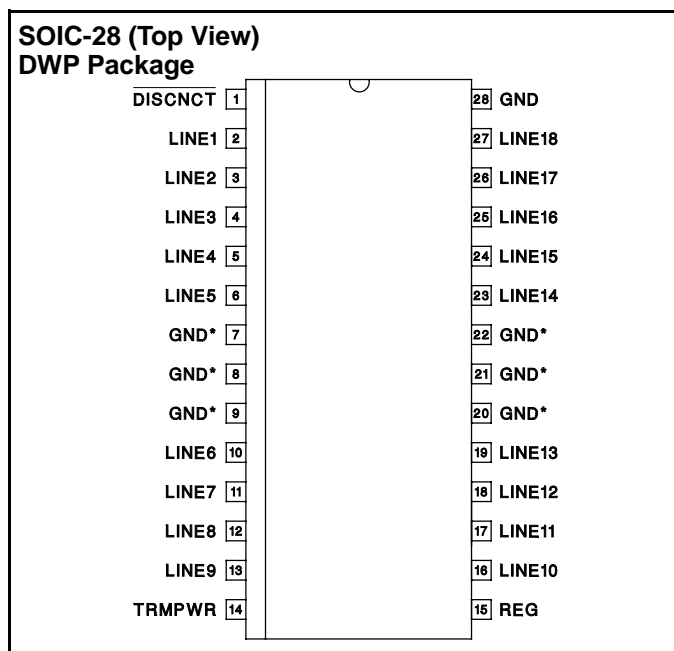

* DWP package pin 28 serves as signal ground; pins 7, 8, 9, 20, 21, 22 serve as heatsink/ground.

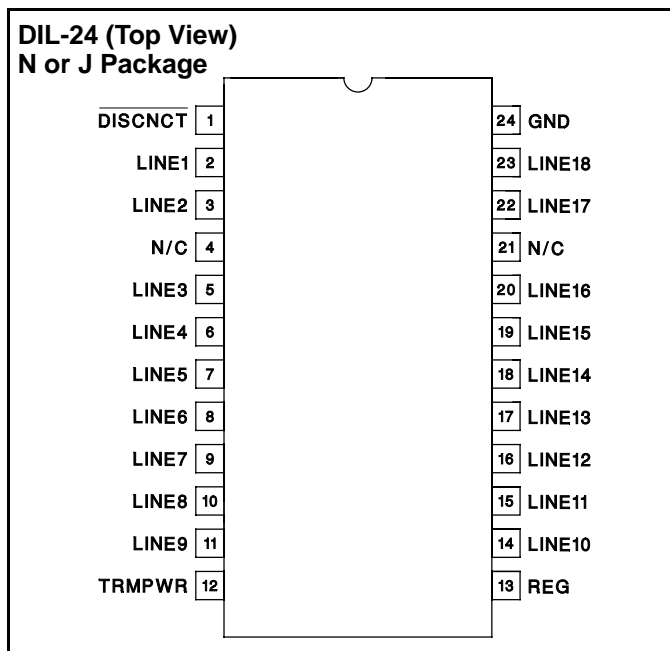

Note: Drawings are not to scale.

ELECTRICAL CHARACTERISTICS Unless otherwise stated, these specifications apply for $T_A = 0^\circ\text{C}$ to 70°C . TRMPWR = 4.75V, DISCNCT = 2.4V. $T_A = T_J$.

PARAMETER	TEST CONDITIONS	MIN	TYP	MAX	UNITS	
Supply Current Section						
Tempwr Supply Current	All termination lines = Open		17	25	mA	
	All termination lines = 0.5V		400	430	mA	
Power Down Mode	DISCNCT = GND		100	150	μA	
Output Section (Terminator Lines)						
Terminator Impedance	$\Delta\text{LINE} = -5\text{mA}$ to -15mA	104.5	110	115.5	Ω	
Output High Voltage	$V_{\text{TRMPWR}} = 4\text{V}$ (Note 1)	2.65	2.9	3.0	V	
Max Output Current	$V_{\text{LINE}} = 0.5\text{V}$	$T_J = 25^\circ\text{C}$	-20.3	-21.5	-22.4	mA
		$0^\circ\text{C} < T_J < 70^\circ\text{C}$	-19.8	-21.5	-22.4	mA
Max Output Current	$V_{\text{LINE}} = 0.5\text{V}$, TRMPWR = 4V (Note 1)	$T_J = 25^\circ\text{C}$	-19.5	-21.5	-22.4	mA
		$0^\circ\text{C} < T_J < 70^\circ\text{C}$	-19.0	-21.5	-22.4	mA
	$V_{\text{LINE}} = 0.2\text{V}$, TRMPWR = 4V to 5.25V	$0^\circ\text{C} < T_J < 70^\circ\text{C}$	-21.6	-24.0	-25.4	mA
Output Leakage	DISCNCT = GND	TRMPWR = 0V to 5.25V REG = 0V	$V_{\text{LINE}} = 0$ to 4V	10	400	nA
		TRMPWR = 0V to 5.25V, REG = Open $V_{\text{LINE}} = 0\text{V}$ to 5.25V	$V_{\text{LINE}} = 5.25\text{V}$		100	μA
				10	400	nA
Output Capacitance	DISCNCT = GND (Note 2)		6	7	pF	
Regulator Section						
Regulator Output Voltage		2.8	2.9	3	V	
Regulator Output Voltage	All Termination Lines = 4V	2.8	2.9	3	V	
Line Regulation	TRMPWR = 4V to 6V		10	20	mV	
Drop Out Voltage	All Termination Lines = 0.5V		1.0	1.2	V	
Short Circuit Current	$V_{\text{REG}} = 0\text{V}$	-450	-650	-950	mA	
Sinking Current Capability	$V_{\text{REG}} = 3.5\text{V}$	100	200	500	mA	
Thermal Shutdown			170		$^\circ\text{C}$	
Thermal Shutdown Hysteresis			10		$^\circ\text{C}$	
Disconnect Section						
Disconnect Threshold		1.1	1.4	1.7	V	

Note 1: Measuring each termination line while other 17 are low (0.5V).

Note 2: Guaranteed by design. Not 100% tested in production.

APPLICATION INFORMATION

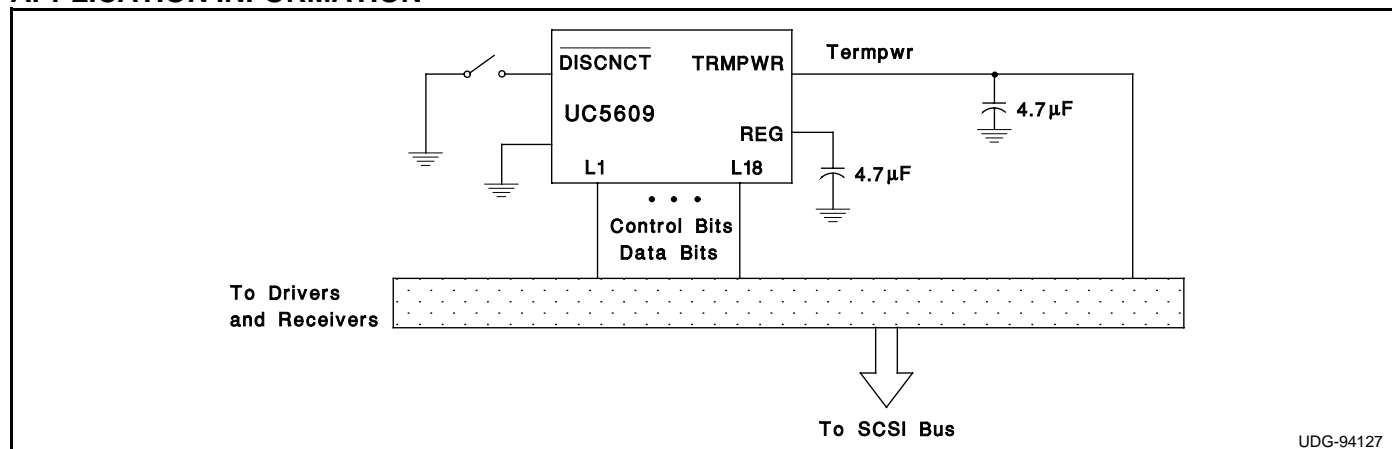

Figure 1: Typical SCSI Bus Configuration

IMPORTANT NOTICE

Texas Instruments and its subsidiaries (TI) reserve the right to make changes to their products or to discontinue any product or service without notice, and advise customers to obtain the latest version of relevant information to verify, before placing orders, that information being relied on is current and complete. All products are sold subject to the terms and conditions of sale supplied at the time of order acknowledgement, including those pertaining to warranty, patent infringement, and limitation of liability.

TI warrants performance of its semiconductor products to the specifications applicable at the time of sale in accordance with TI's standard warranty. Testing and other quality control techniques are utilized to the extent TI deems necessary to support this warranty. Specific testing of all parameters of each device is not necessarily performed, except those mandated by government requirements.

CERTAIN APPLICATIONS USING SEMICONDUCTOR PRODUCTS MAY INVOLVE POTENTIAL RISKS OF DEATH, PERSONAL INJURY, OR SEVERE PROPERTY OR ENVIRONMENTAL DAMAGE ("CRITICAL APPLICATIONS"). TI SEMICONDUCTOR PRODUCTS ARE NOT DESIGNED, AUTHORIZED, OR WARRANTED TO BE SUITABLE FOR USE IN LIFE-SUPPORT DEVICES OR SYSTEMS OR OTHER CRITICAL APPLICATIONS. INCLUSION OF TI PRODUCTS IN SUCH APPLICATIONS IS UNDERSTOOD TO BE FULLY AT THE CUSTOMER'S RISK.

In order to minimize risks associated with the customer's applications, adequate design and operating safeguards must be provided by the customer to minimize inherent or procedural hazards.

TI assumes no liability for applications assistance or customer product design. TI does not warrant or represent that any license, either express or implied, is granted under any patent right, copyright, mask work right, or other intellectual property right of TI covering or relating to any combination, machine, or process in which such semiconductor products or services might be or are used. TI's publication of information regarding any third party's products or services does not constitute TI's approval, warranty or endorsement thereof.