

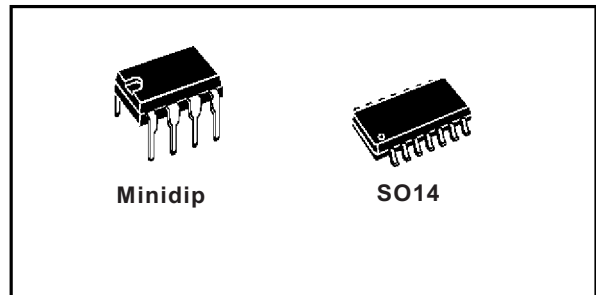

UC2842/3/4/5 UC3842/3/4/5

CURRENT MODE PWM CONTROLLER

- OPTIMIZED FOR OFF-LINE AND DC TO DC CONVERTERS
- LOW START-UP CURRENT ($< 1 \text{ mA}$)
- AUTOMATIC FEED FORWARD COMPENSATION
- PULSE-BY-PULSE CURRENT LIMITING
- ENHANCED LOAD RESPONSE CHARACTERISTICS
- UNDER-VOLTAGE LOCKOUT WITH HYSTERESIS
- DOUBLE PULSE SUPPRESSION
- HIGH CURRENT TOTEM POLE OUTPUT
- INTERNALLY TRIMMED BANDGAP REFERENCE
- 500 KHz OPERATION
- LOW R_o ERROR AMP



logic to insure latched operation, a PWM comparator which also provides current limit control, and a totem pole output stage designed to source or sink high peak current. The output stage, suitable for driving N-Channel MOSFETs, is low in the off-state.

Differences between members of this family are the under-voltage lockout thresholds and maximum duty cycle ranges. The UC3842 and UC3844 have UVLO thresholds of 16V (on) and 10V (off), ideally suited off-line applications. The corresponding thresholds for the UC3843 and UC3845 are 8.5 V and 7.9 V. The UC3842 and UC3843 can operate to duty cycles approaching 100%. A range of the zero to $< 50 \%$ is obtained by the UC3844 and UC3845 by the addition of an internal toggle flip flop which blanks the output off every other clock cycle.

DESCRIPTION

The UC3842/3/4/5 family of control ICs provides the necessary features to implement off-line or DC to DC fixed frequency current mode control schemes with a minimal external parts count. Internally implemented circuits include undervoltage lockout featuring start-up current less than 1 mA, a precision reference trimmed for accuracy at the error amp input,

BLOCK DIAGRAM (toggle flip flop used only in U3844 and UC3845)

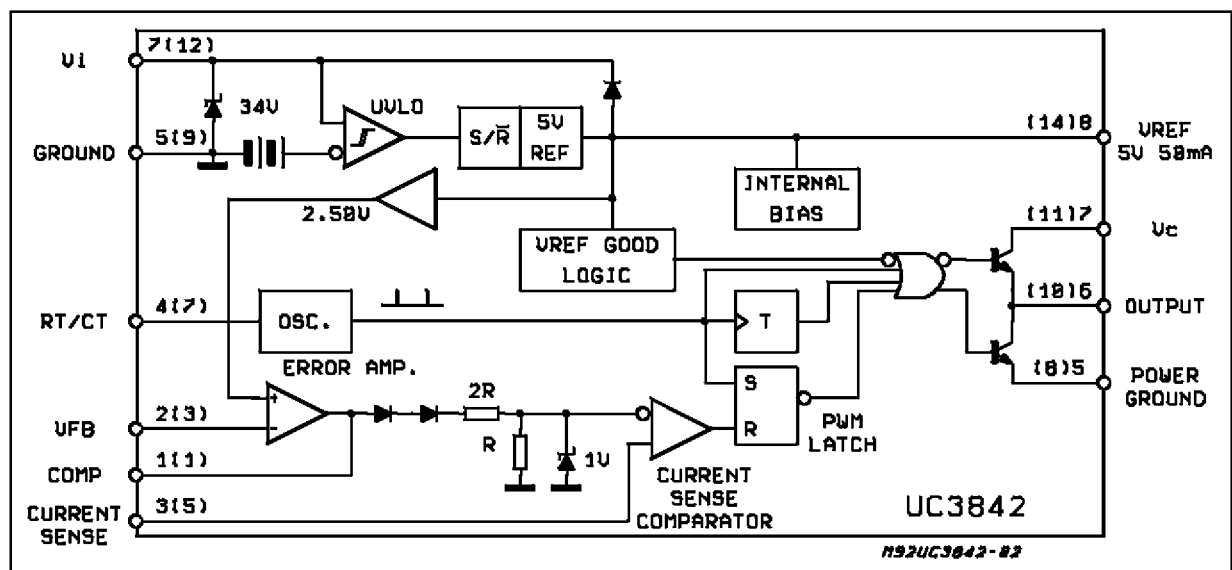

UC2842/3/4/5-UC3842/3/4/5

ABSOLUTE MAXIMUM RATINGS

Symbol	Parameter	Value	Unit
V_i	Supply Voltage (low impedance source)	30	V
V_i	Supply Voltage ($I_i < 30\text{mA}$)	Self Limiting	
I_o	Output Current	± 1	A
E_o	Output Energy (capacitive load)	5	μJ
	Analog Inputs (pins 2, 3)	- 0.3 to 6.3	V
	Error Amplifier Output Sink Current	10	mA
P_{tot}	Power Dissipation at $T_{\text{amb}} \leq 50^\circ\text{C}$ (minidip, DIP-14)	1	W
P_{tot}	Power Dissipation at $T_{\text{amb}} \leq 25^\circ\text{C}$ (SO14)	725	mW
T_{stg}	Storage Temperature Range	- 65 to 150	$^\circ\text{C}$
T_L	Lead Temperature (soldering 10s)	300	$^\circ\text{C}$

* All voltages are with respect to pin 5, all currents are positive into the specified terminal.

PIN CONNECTIONS (top views)

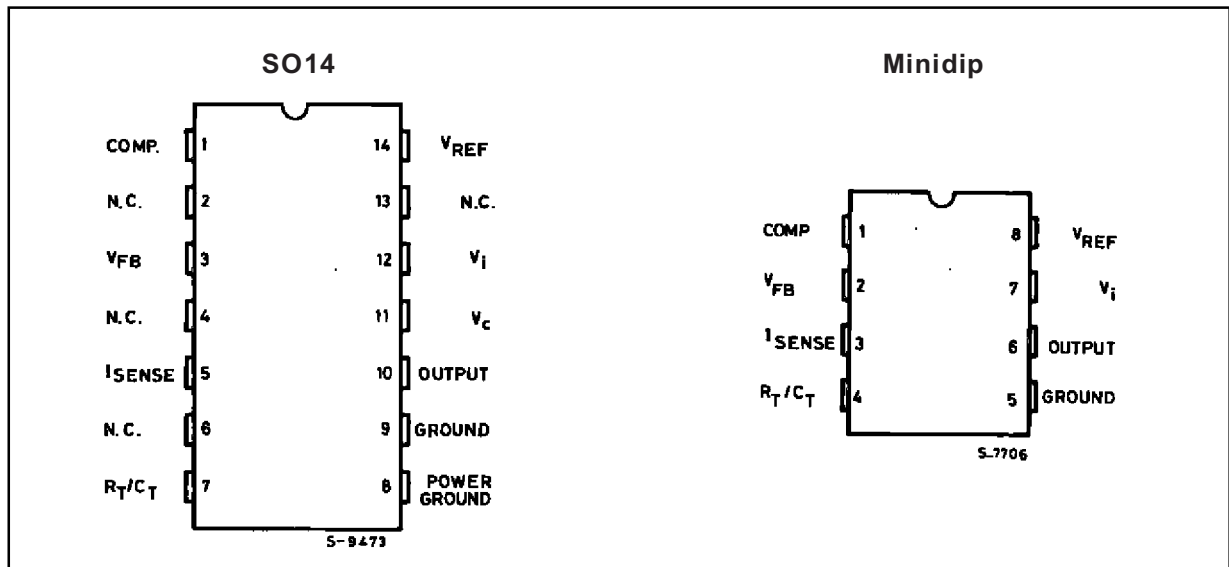

ORDERING NUMBERS

Type	Minidip	SO14
UC2842	UC2842N	UC2842D
UC3843	UC2843N	UC2843D
UC2844	UC2844N	UC2844D
UC2845	UC2845N	UC2845D
UC3842	UC3842N	UC3842D
UC3843	UC3843N	UC3843D
UC3844	UC3844N	UC3844D
UC3845	UC3845N	UC3845D

THERMAL DATA

Symbol	Description	Minidip	SO14	Unit
$R_{\text{thj-amb}}$	Thermal Resistance Junction-ambient.	max. 100	165	$^\circ\text{C}$

ELECTRICAL CHARACTERISTICS (Unless otherwise stated, these specifications apply for $-25 \leq T_{amb} \leq 85^{\circ}\text{C}$ for UC2824X; $0 \leq T_{amb} \leq 70^{\circ}\text{C}$ for UC384X; $V_i = 15\text{V}$ (note 5); $R_T = 10\text{K}$; $C_T = 3.3\text{nF}$)

Symbol	Parameter	Test Conditions	UC284X			UC384X			Unit
			Min.	Typ.	Max.	Min.	Typ.	Max.	
REFERENCE SECTION									
V_{REF}	Output Voltage	$T_j = 25^{\circ}\text{C}$ $I_o = 1\text{mA}$	4.95	5.00	5.05	4.90	5.00	5.10	V
ΔV_{REF}	Line Regulation	$12\text{V} \leq V_i \leq 25\text{V}$		6	20		6	20	mV
ΔV_{REF}	Load Regulation	$1 \leq I_o \leq 20\text{mA}$		6	25		6	25	mV
$\Delta V_{REF}/\Delta T$	Temperature Stability	(Note 2)		0.2	0.4		0.2	0.4	mV/ $^{\circ}\text{C}$
	Total Output Variant	Line, Load, Temperature (2)	4.9		5.1	4.82		5.18	V
e_N	Output Noise Voltage	$10\text{Hz} \leq f \leq 10\text{KHz}$ $T_j = 25^{\circ}\text{C}$ (2)		50			50		μV
	Long Term Stability	$T_{amb} = 125^{\circ}\text{C}$, 1000Hrs (2)		5	25		5	25	mV
I_{SC}	Output Short Circuit		-30	-100	-180	-30	-100	-180	mA
OSCILLATOR SECTION									
f_s	Initial Accuracy	$T_j = 25^{\circ}\text{C}$ (6)	47	52	57	47	52	57	KHz
	Voltage Stability	$12 \leq V_i \leq 25\text{V}$		0.2	1		0.2	1	%
	Temperature Stability	$T_{MIN} \leq T_{amb} \leq T_{MAX}$ (2)		5			5		%
V_4	Amplitude	V_{PIN4} Peak to Peak		1.7			1.7		V
ERROR AMP SECTION									
V_2	Input Voltage	$V_{PIN1} = 2.5\text{V}$	2.45	2.50	2.55	2.42	2.50	2.58	V
I_b	Input Bias Current			-0.3	-1		-0.3	-2	μA
	A_{VOL}	$2 \leq V_o \leq 4\text{V}$	65	90		65	90		dB
B	Unity Gain Bandwidth	(2)	0.7	1		0.7	1		MHz
SVR	Supply Voltage Rejection	$12\text{V} \leq V_i \leq 25\text{V}$	60	70		60	70		dB
I_o	Output Sink Current	$V_{PIN2} = 2.7\text{V}$ $V_{PIN1} = 1.1\text{V}$	2	6		2	6		V
I_o	Output Source Current	$V_{PIN2} = 2.3\text{V}$ $V_{PIN1} = 5\text{V}$	-0.5	-0.8		-0.5	-0.8		mA
	V_{OUT} High	$V_{PIN2} = 2.3\text{V}$; $R_L = 15\text{K}\Omega$ to Ground	5	6		5	6		V
	V_{OUT} Low	$V_{PIN2} = 2.7\text{V}$; $R_L = 15\text{K}\Omega$ to Pin 8		0.7	1.1		0.7	1.1	V
CURRENT SENSE SECTION									
G_V	Gain	(3 & 4)	2.85	3	3.15	2.8	3	3.2	V/V
V_3	Maximum Input Signal	$V_{PIN1} = 5\text{V}$ (3)	0.9	1	1.1	0.9	1	1.1	V
SVR	Supply Voltage Rejection	$12 \leq V_i \leq 25\text{V}$ (3)		70			70		dB
I_b	Input Bias Current			-2	-10		-2	-10	μA
	Delay to Output			150	300		150	300	ns
OUTPUT SECTION									
I_{OL}	Output Low Level	$I_{SINK} = 20\text{mA}$		0.1	0.4		0.1	0.4	V
		$I_{SINK} = 200\text{mA}$		1.5	2.2		1.5	2.2	V
I_{OH}	Output High Level	$I_{SOURCE} = 20\text{mA}$	13	13.5		13	13.5		V
		$I_{SOURCE} = 200\text{mA}$	12	13.5		12	13.5		V
t_r	Rise Time	$T_j = 25^{\circ}\text{C}$ $C_L = 1\text{nF}$ (2)		50	150		50	150	ns
t_f	Fall Time	$T_j = 25^{\circ}\text{C}$ $C_L = 1\text{nF}$ (2)		50	150		50	150	ns

ELECTRICAL CHARACTERISTICS (continued)

Symbol	Parameter	Test Conditions	UC284X			UC384X			Unit
			Min.	Typ.	Max.	Min.	Typ.	Max.	
UNDER-VOLTAGE LOCKOUT SECTION									
	Start Threshold	X842/4	15	16	17	14.5	16	17.5	V
		X843/5	7.8	8.4	9.0	7.8	8.4	9	V
	Min Operating Voltage After Turn-on	X842/4	9	10	11	8.5	10	11.5	V
		X843/5	7.0	7.6	8.2	7.0	7.6	8.2	V
PWM SECTION									
	Maximum Duty Cycle	X842/3	93	97	100	93	97	100	%
		X844/5	46	48	50	47	48	50	%
	Minimum Duty Cycle				0			0	%
TOTAL STANDBY CURRENT									
I _{st}	Start-up Current			0.5	1		0.5	1	mA
I _i	Operating Supply Current	V _{PIN2} = V _{PIN3} = 0V		11	20		11	20	mA
V _{iz}	Zener Voltage	I _i = 25mA		34			34		V

- Notes :**
2. These parameters, although guaranteed, are not 100% tested in production.
 3. Parameter measured at trip point of latch with V_{PIN2} = 0.
 4. Gain defined as :

$$A = \frac{\Delta V_{PIN1}}{\Delta V_{PIN3}} ; 0 \leq V_{PIN3} \leq 0.8V$$
 5. Adjust V₁ above the start threshold before setting at 15 V.
 6. Output frequency equals oscillator frequency for the UC3842 and UC3843.
 Output frequency is one half oscillator frequency for the UC3844 and UC3845.

Figure 1 : ErrorAmp Configuration.

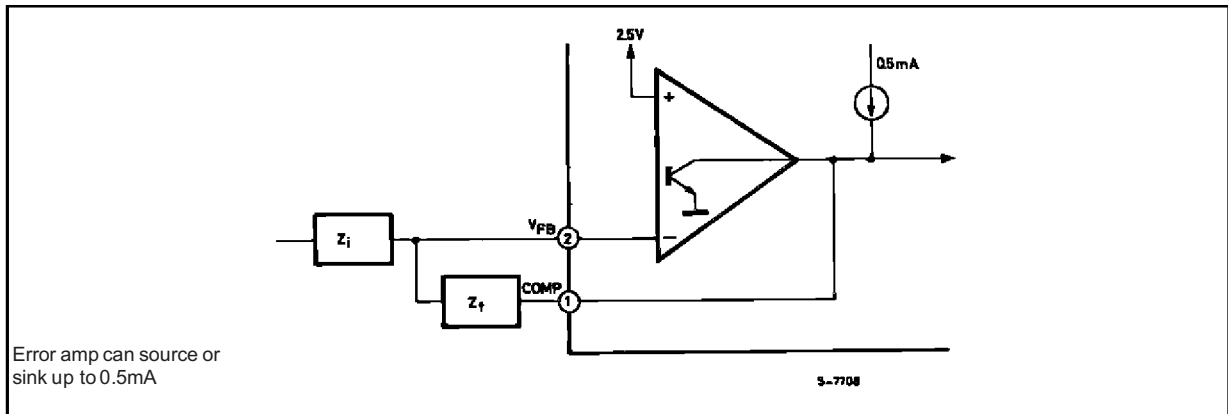
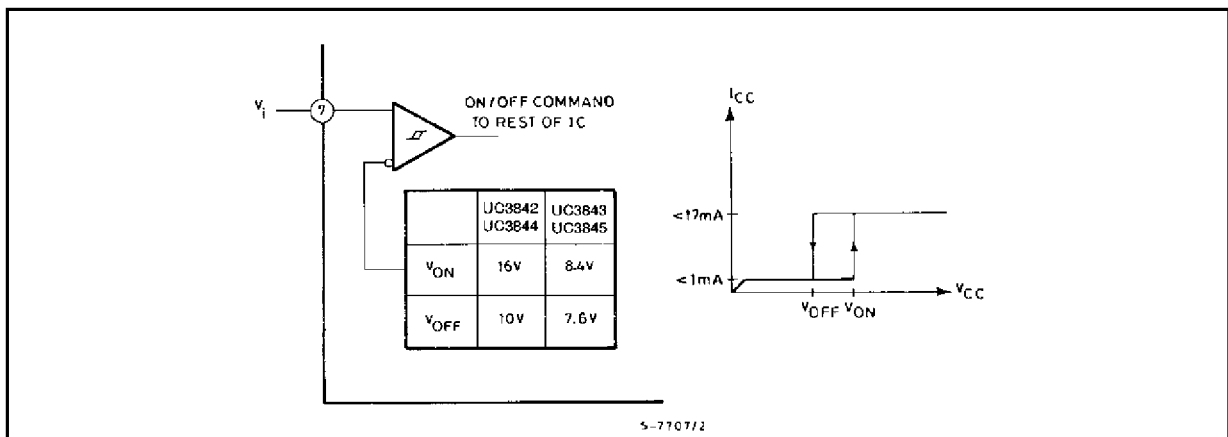

Figure 2 : UnderVoltage Lockout.



During Under-Voltage Lockout, the output driver is biased to sink minor amounts of current. Pin 6 should be shunted to ground with a bleeder resistor

to prevent activating the power switch with extraneous leakage currents.

Figure 3 : Current Sense Circuit .

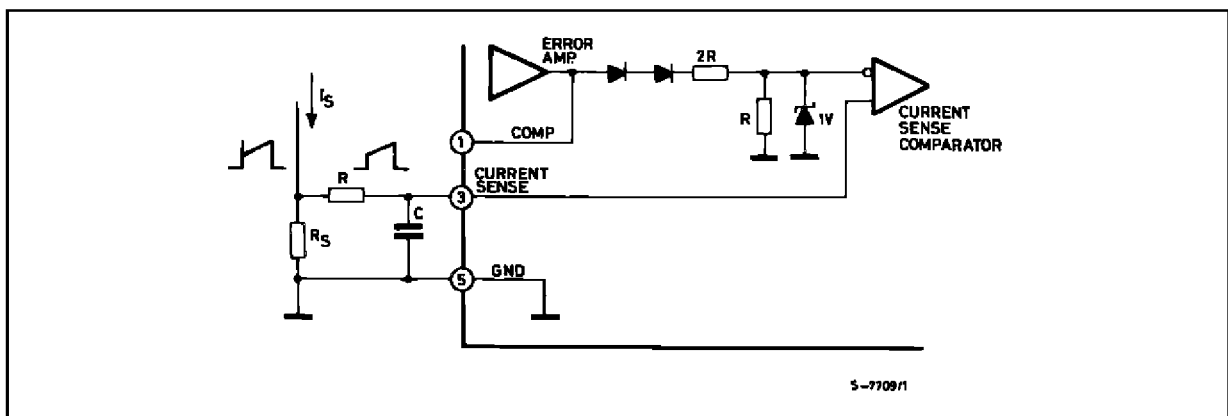

Peak current (i_s) is determined by the formula

$$I_{s \text{ max}} \approx \frac{1.0 \text{ V}}{R_s}$$

A small RC filter may be required to suppress switch transients.

Figure 4.

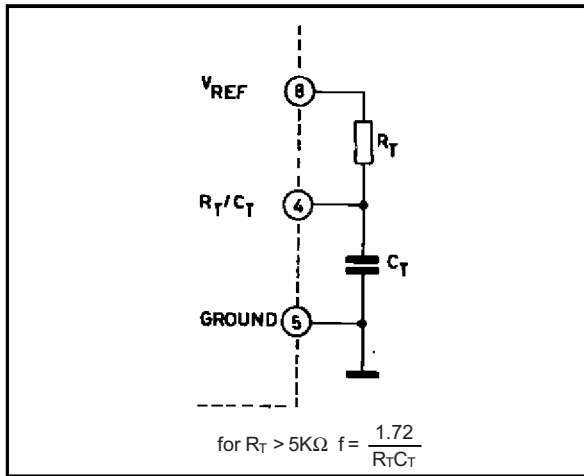

Figure 5 : Deadtime vs. C_T ($R_T > 5K\Omega$).

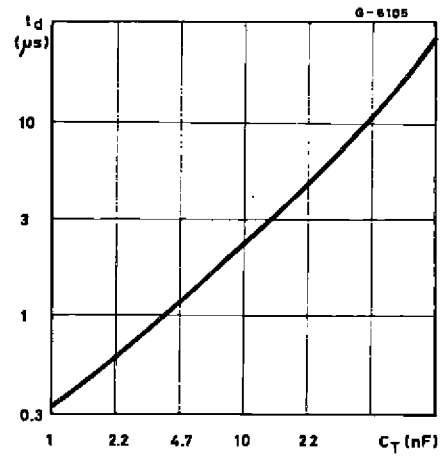

Figure 6 : Timing Resistance vs. Frequency.

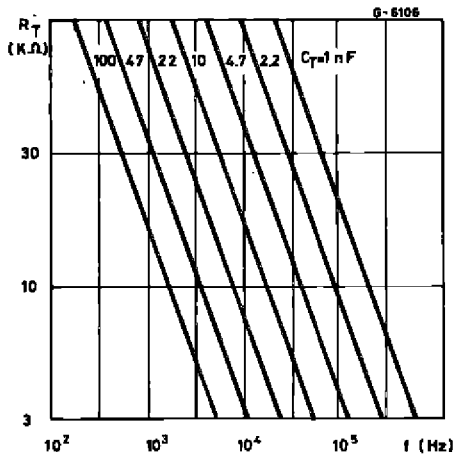

Figure 7 : Output Saturation Characteristics.

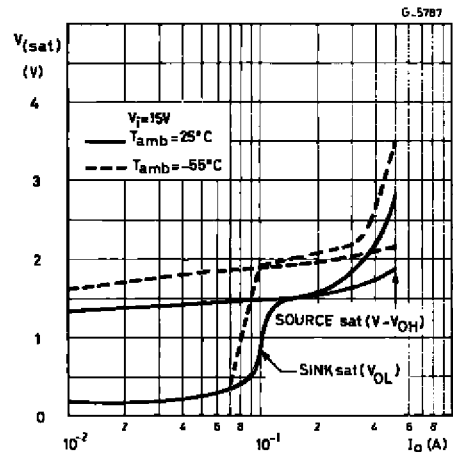

Figure 8 : Error Amplifier Open-loop Frequency Response.

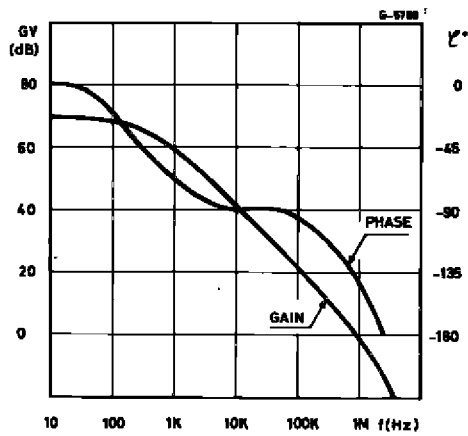
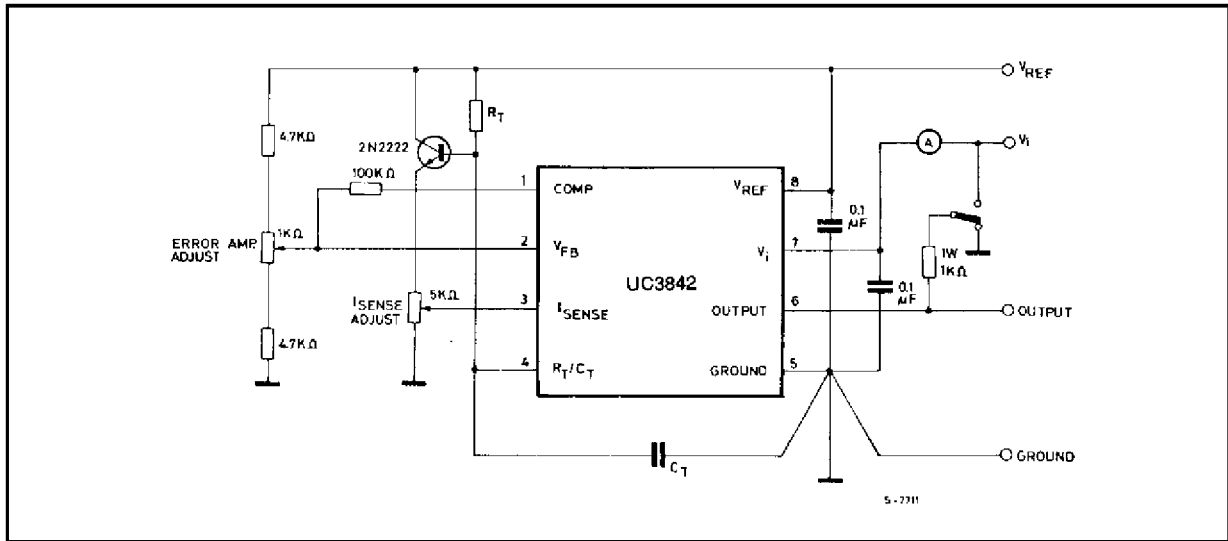

Figure 9 : Open Loop Test Circuit.



High peak currents associated with capacitive loads necessitate careful grounding techniques. Timing and bypass capacitors should be connected close

to pin 5 in a single point ground. The transistor and 5 kΩ potentiometer are used to sample the oscillator waveform and apply an adjustable ramp to pin 3.

Figure 10 : Shutdown Techniques.

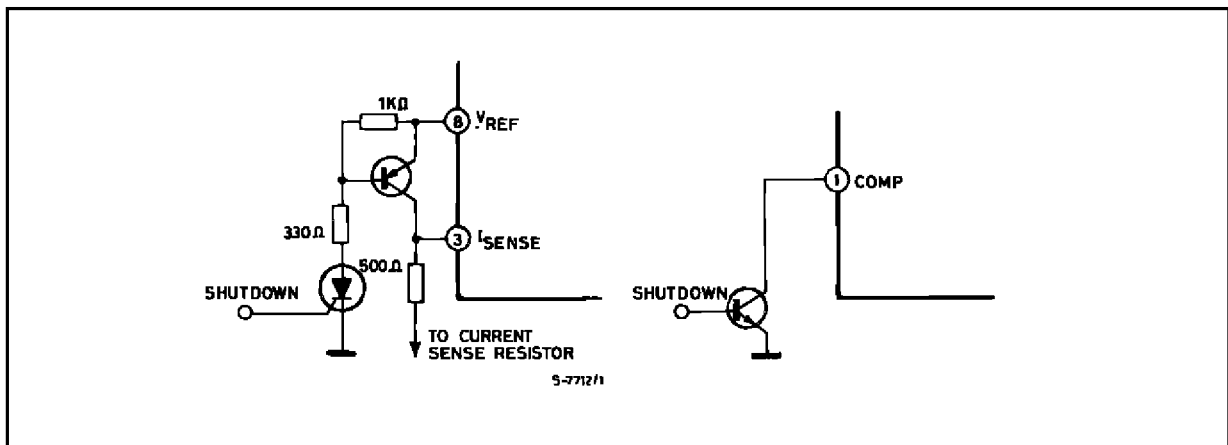

Shutdown of the UC2842 can be accomplished by two methods; either raise pin 3 above 1V or pull pin 1 below a voltage two diode drops above ground. Either method cause the output of the PWM comparator to be high (refer to block diagram). The PWM latch is reset dominant so that the output will remain low until the next clock cycle after the shut-

down condition at pins 1 and/or 3 is removed. In one example, an externally latched shutdown may be accomplished by adding an SCR which will be reset by cycling V_i below the lower UVLO threshold. At this point the reference turns off, allowing the SCR to reset.

Figure 11 : Off-line Flyback Regulator.

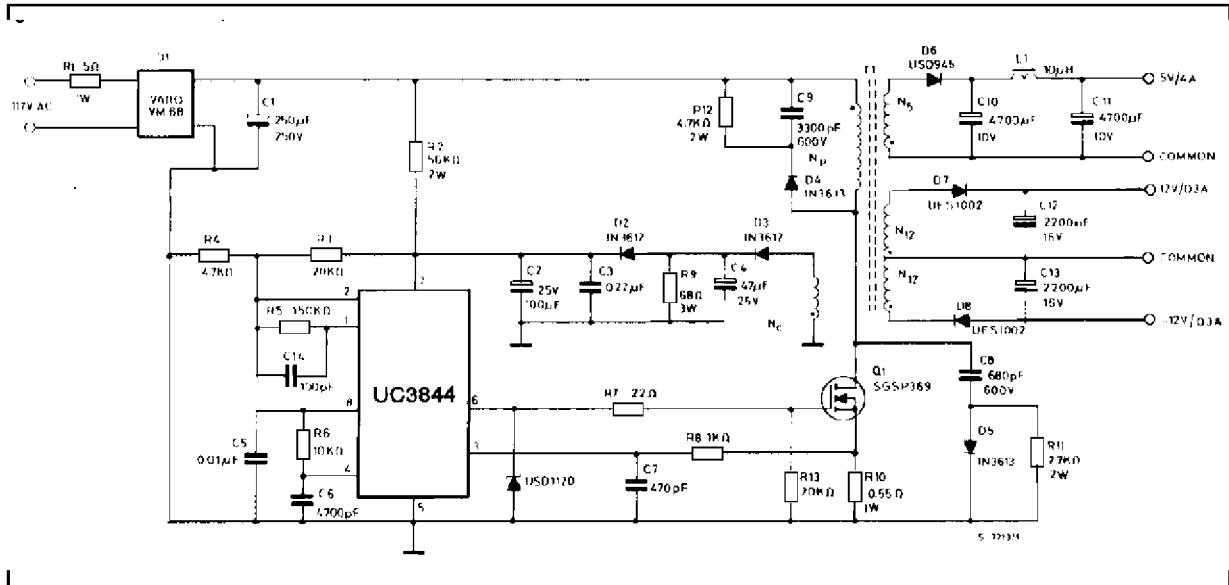

Power Supply Specifications

- | | | | |
|-----------------------------|------------------------------------|---------------------|--|
| 1. Input Voltage : | 95 VAC to 130 VAC
(50 Hz/60 Hz) | 5. Output Voltage : | A. + 5 V, ± 5 % : 1 A to 4 A load
Ripple voltage : 50 mV P-P Max. |
| 2. Line Isolation : | 3750 V | | B. + 12 V, ± 3 % : 0.1 A to 0.3 A load
Ripple voltage : 100 mV P-P Max. |
| 3. Switching Frequency : | 40 KHz | | C. - 12 V, ± 3 % : 0.1 A to 0.3 A load
Ripple voltage : 100 mV P-P Max. |
| 4. Efficiency @ Full Load : | 70 % | | |

Figure 12 : Slope Compensation.

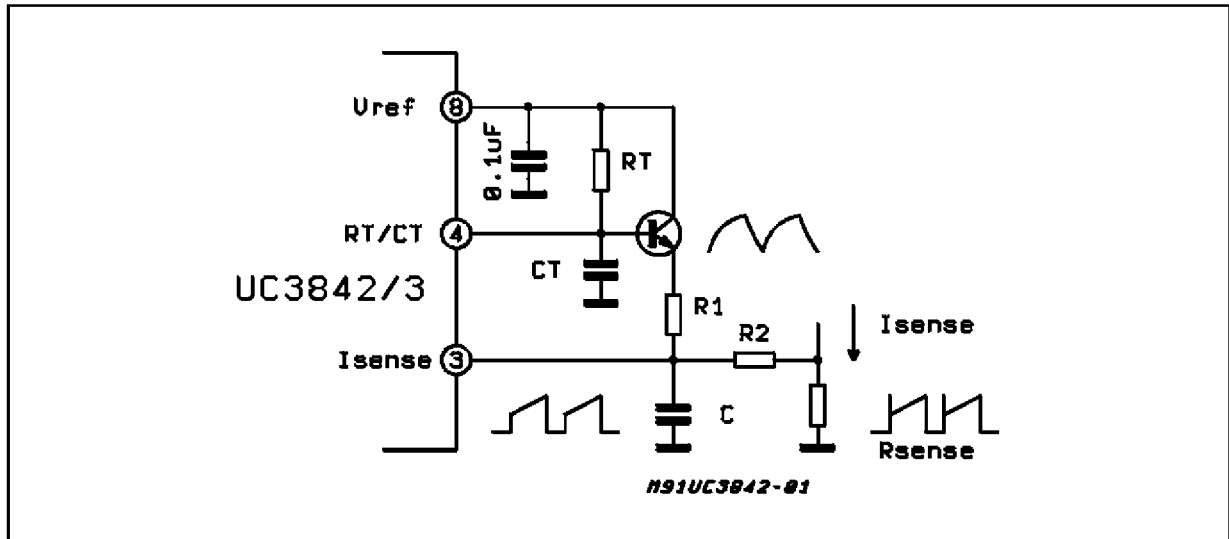

A fraction of the oscillator ramp can be resistively summed with the current sense signal to provide slope compensation for converters requiring duty cycles over 50 %.

Note that capacitor, C, forms a filter with R₂ to suppress the leading edge switch spikes.

DIM.	mm			inch		
	MIN..	TYP.	MAX..	MIN..	TYP..	MAX..
A			1.75			0.069
a1	0.1		0.25	0.004		0.009
a2			1.6			0.063
b	0.35		0.46	0.014		0.018
b1	0.19		0.25	0.007		0.010
C		0.5			0.020	
c1	45° (typ.)					
D (1)	8.55		8.75	0.336		0.344
E	5.8		6.2	0.228		0.244
e		1.27			0.050	
e3		7.62			0.300	
F (1)	3.8		4	0.150		0.157
G	4.6		5.3	0.181		0.209
L	0.4		1.27	0.016		0.050
M			0.68			0.027
S	8° (max)					

OUTLINE AND MECHANICAL DATA

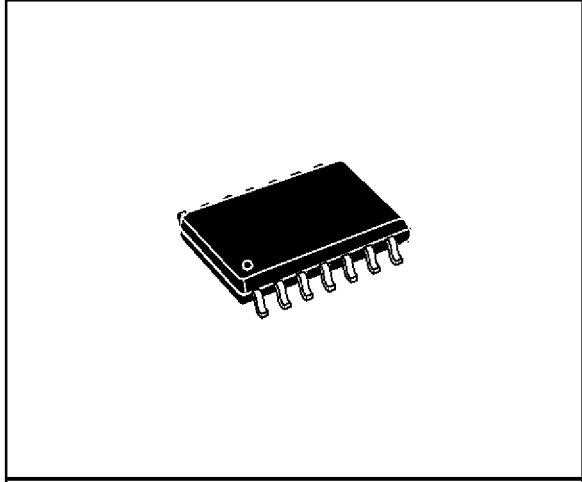

SO14

(1) D and F do not include mold flash or protrusions. Mold flash or protrusions shall not exceed 0.15mm (.006inch).

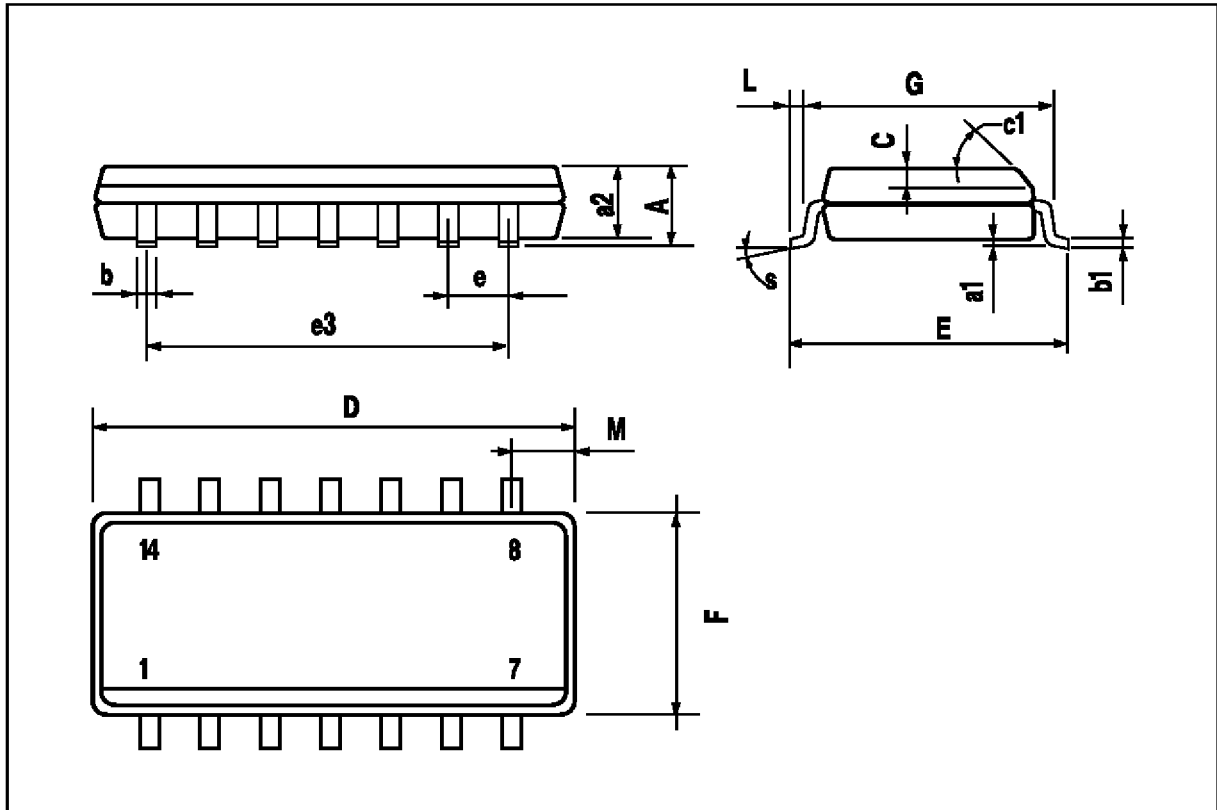

DIM.	mm			inch		
	MIN.	TYP.	MAX.	MIN.	TYP.	MAX.
A		3.3			0.130	
a1	0.7			0.028		
B	1.39		1.65	0.055		0.065
B1	0.91		1.04	0.036		0.041
b		0.5			0.020	
b1	0.38		0.5	0.015		0.020
D			9.8			0.386
E		8.8			0.346	
e		2.54			0.100	
e3		7.62			0.300	
e4		7.62			0.300	
F			7.1			0.280
I			4.8			0.189
L		3.3			0.130	
Z	0.44		1.6	0.017		0.063

OUTLINE AND MECHANICAL DATA

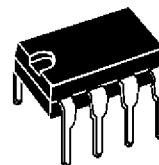

Minidip 0.300"

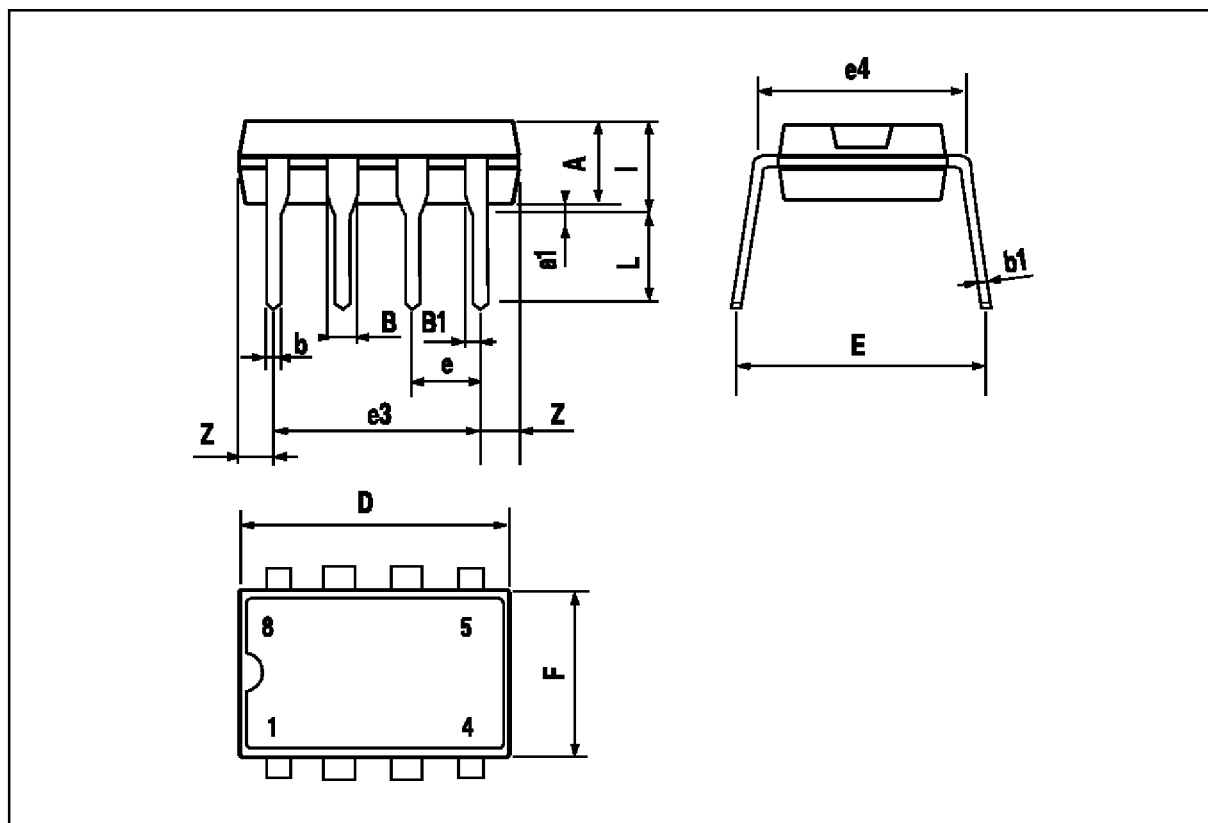

Information furnished is believed to be accurate and reliable. However, STMicroelectronics assumes no responsibility for the consequences of use of such information nor for any infringement of patents or other rights of third parties which may result from its use. No license is granted by implication or otherwise under any patent or patent rights of STMicroelectronics. Specification mentioned in this publication are subject to change without notice. This publication supersedes and replaces all information previously supplied. STMicroelectronics products are not authorized for use as critical components in life support devices or systems without express written approval of STMicroelectronics.

The ST logo is a registered trademark of STMicroelectronics
© 1998 STMicroelectronics – Printed in Italy – All Rights Reserved
STMicroelectronics GROUP OF COMPANIES

Australia - Brazil - Canada - China - France - Germany - Italy - Japan - Korea - Malaysia - Malta - Mexico - Morocco - The Netherlands -
Singapore - Spain - Sweden - Switzerland - Taiwan - Thailand - United Kingdom - U.S.A.

<http://www.st.com>

