

# DATA SHEET

## **UAA3202M** Frequency Shift Keying (FSK) receiver

Preliminary specification  
File under Integrated Circuits, IC01

1997 Aug 12

## Frequency Shift Keying (FSK) receiver

## UAA3202M

### FEATURES

- Low cost single-chip FSK receiver
- Superheterodyne architecture with high integration level
- Few external low cost components
- Wide supply voltage range
- Low power consumption
- Wide frequency range, 150 to 450 MHz
- High sensitivity
- IF band determined by application
- High selectivity
- Very low spurious radiation, -60 dBm (meets FTZ 17TR2100)
- Automotive temperature range
- Power-down mode
- SSOP20 package.

### Applications

- Keyless entry systems
- Car alarm systems
- Remote control systems
- Security systems
- Telemetry systems
- Wireless data transmission
- Domestic appliances.

### GENERAL DESCRIPTION

The UAA3202M is a fully integrated single-chip receiver, primarily intended for use in VHF and UHF systems employing direct Frequency Shift Keying (FSK) modulation. The UAA3202M incorporates a SAW stabilized local oscillator, balanced mixer, IF amplifier, limiter, Received Signal Strength Indicator (RSSI), RSSI comparator, FSK demodulator, data filter and data slicer. The device features a power-down mode in order to minimize the average receiver supply current.

### QUICK REFERENCE DATA

SYMBOL	PARAMETER	CONDITIONS	MIN.	TYP.	MAX.	UNIT
V <sub>CC</sub>	supply voltage		3.5	–	6	V
I <sub>CC</sub>	supply current for operating mode on operating mode off	V <sub>PWD</sub> = 0 V; R <sub>2</sub> = 560 Ω V <sub>PWD</sub> = V <sub>CC</sub>	2.0 –	3.4 3	4.7 30	mA μA
P <sub>sens</sub>	sensitivity	f <sub>i</sub> = 433.92 MHz; f <sub>mod</sub> = 250 Hz square wave; Δf = ±25 kHz; BER ≤ 3%	–	–	–94	dBm
T <sub>amb</sub>	operating ambient temperature		–40	–	+85	°C

### ORDERING INFORMATION

TYPE NUMBER	PACKAGE		
	NAME	DESCRIPTION	VERSION
UAA3202M	SSOP20	plastic shrink small outline package; 20 leads; body width 5.3 mm	SOT339-1



Frequency Shift Keying (FSK) receiver

UAA3202M

**PINNING**

SYMBOL	PIN	DESCRIPTION
MON	1	negative mixer output
MOP	2	positive mixer output
V <sub>CC</sub>	3	positive supply voltage
OSC	4	oscillator collector
OSE	5	oscillator emitter
V <sub>EO</sub>	6	negative supply voltage for oscillator
V <sub>EE</sub>	7	negative supply voltage
COMP	8	RSSI comparator output
CPB	9	comparator input B
CPA	10	comparator input A
DATA	11	data output
PWD	12	power-down control input
CPC	13	comparator input C
DMOD	14	demodulator frequency adjustment
RSSI	15	RSSI current output
LFB	16	limiter feedback
LIN	17	limiter input
MXIN	18	mixer input
V <sub>EM</sub>	19	negative supply voltage for mixer
FA	20	IF amplifier output

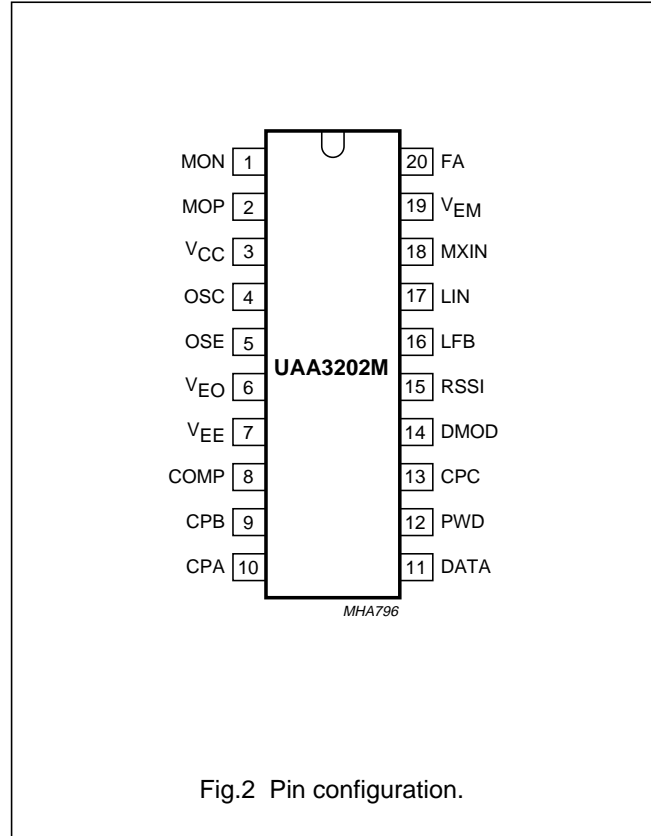

Fig.2 Pin configuration.

## Frequency Shift Keying (FSK) receiver

UAA3202M

### FUNCTIONAL DESCRIPTION

The device is based on the superheterodyne architecture incorporating a mixer, local oscillator, IF amplifier, limiter, RSSI, RSSI comparator, FSK demodulator, data filter, data slicer and power-down circuitry. The device employs a low IF frequency of typically 1 MHz in order to allow IF filtering by means of external low cost R, L and C components. If image rejection is required it can be achieved by applying a matching external front-end SAW filter. The device provides a wide IF range of 300 kHz in order to allow the use of a SAW stabilized oscillator.

The on-chip local oscillator provides the injection signal for the mixer. Tuning of the on-chip local oscillator is not necessary. The oscillator frequency is determined by an external 1-port SAW resonator. The RF input signal is fed to the mixer and down converted to the IF frequency. After amplification and filtering the RF signal is applied to a limiter. The IF filter order and characteristics are determined by the external low cost R, L and C components. The limiter amplifier provides a RSSI signal which can be routed to an on-chip RSSI level comparator in order to derive a field strength indication for external use. The limited IF signal is fed to the FSK demodulator. The demodulator centre frequency is determined by an external capacitor. No alignment is necessary for the FSK demodulator. After filtering the demodulated data signal is fed to a data slicer and is made available at the data output. The data filter characteristics are determined by external capacitors. The data slicer employs an adaptive slice reference in order to track frequency offsets.

The device is switched from power-down to operating mode and vice versa by means of a control input. Extremely low supply current is drawn when the device is in power-down mode. Measures are taken to allow fast receiver settling when the device is switched from power-down to operating mode.

#### Mixer

The mixer is a single balanced emitter coupled mixer with internal biasing. Matching of the RF source impedance to the mixer input requires an external matching network.

#### Oscillator

The oscillator consists of an on-chip transistor in common base configuration. An external tank and SAW resonator determines the oscillator frequency. Oscillator alignment is not necessary. Oscillator bias is controlled by an external resistor.

#### Post mixer amplifier

The Post Mixer Amplifier (PMA) is a differential input, single-ended output amplifier. It separates the first and second IF filters from each other. Amplifier gain is provided in order to reduce the influence of the limiter noise figure on the total noise figure.

#### Limiter

The limiter is a single-ended input multiple stage amplifier with high total gain. Amplifier stability is achieved by means of an external DC feedback capacitor, which is also used to determine the lower limiter cut-off frequency. An RSSI signal proportional to the limiter input signal is provided.

#### IF filters

IF filtering with high selectivity is realized by means of external low cost R, L and C components. The first IF filter is located directly following the mixer output. An external L/C network assembles a band-pass with low sensitivity in order to meet the bandwidth of an elliptic low-pass filter external to the device and is located in front of the limiter. The filter source impedance is determined by the drive impedance of the IF amplifier. In order to improve the IF filter selectivity below the pass-band a high-pass characteristic is added by means of a DC blocking capacitor in front of the limiter input and by means of the limiter DC feedback capacitor.

#### RSSI

The RSSI signal is a current proportional to the limiter input level (RF input power). By means of an external resistor the resulting RSSI voltage level is set in order to fit the application. The RSSI voltage is available to external circuits and is fed to the input of the RSSI level comparator. For RSSI filtering an external capacitor is connected.

#### RSSI level comparator

The RSSI level comparator compares the RSSI level with a fixed and independent internal reference voltage. If the RSSI level exceeds the internal reference voltage a logic HIGH signal is generated. The level comparator provides some hysteresis in order to avoid spurious oscillation. The output of the level comparator is designed as an open-collector with internal pull-up.

## Frequency Shift Keying (FSK) receiver

## UAA3202M

### FSK demodulator

The limited IF signal is converted into baseband data by means of a quadrature FM demodulator consisting of an all-pass filter and a mixer stage. No alignment of the demodulator is necessary. The demodulator centre frequency is set by a capacitor external to the device. The demodulator provides a large audio bandwidth in order to allow high data rate applications. The demodulator can detect a small IF frequency deviation even if a relatively large IF frequency offset is encountered.

### Data filters

After demodulation a two-stage data filtering circuit is provided in order to suppress unwanted frequency components. Two R/C low-pass filters with on-chip resistors are provided which are separated by a buffer stage.

### Data slicer

Data detection is provided by means of a level comparator with adaptive slice reference. After the first data filter stage the pre-filtered data is split into two parts. One part passes the second data filter stage and is fed to the positive comparator input.

The other path is fed to an integration circuit with a large time constant in order to derive the average value (DC component) as an adaptive slice reference which is presented to the negative comparator input. The adaptive reference enables the received data over a large range of demodulator frequency offsets to be detected. The integration circuit consists of a simple R/C low-pass filter with on-chip resistor. The level comparator output is designed as an open-collector with internal pull-up.

### Power-down circuitry

The device provides a power-down mode. While in power-down mode the device disables the majority of the internal circuits and consumes extremely low current. Measures are taken to allow fast receiver settling when normal operation is resumed. Thus circuits with large time constants are only powered down partly or provide a high impedance during power-down in order to avoid the discharge of external capacitors as much as possible. Power-down mode is entered when the control input is active HIGH. The control input provides an internal pull-up resistor of high impedance.

## LIMITING VALUES

In accordance with the Absolute Maximum Rating System (IEC 134).

SYMBOL	PARAMETER	CONDITIONS	MIN.	MAX.	UNIT
V <sub>CC</sub>	supply voltage		-0.3	+8.0	V
T <sub>amb</sub>	operating ambient temperature		-40	+85	°C
T <sub>stg</sub>	storage temperature		-55	+125	°C
V <sub>esd</sub>	electrostatic handling	note 1			
	pins 4 and 5		-2000	+1500	V
	pins 18 and 19		-1500	+2000	V
	all other pins		-2000	+2000	V

### Note

- Human body model: equivalent to discharging a 100 pF capacitor through a 1.5 kΩ series resistor.

## THERMAL CHARACTERISTICS

SYMBOL	PARAMETER	VALUE	UNIT
R <sub>th j-a</sub>	thermal resistance from junction to ambient in free air	125	K/W

## Frequency Shift Keying (FSK) receiver

UAA3202M

**DC CHARACTERISTICS** $V_{CC} = 3.5 \text{ V}$ ;  $T_{amb} = 25 \text{ }^\circ\text{C}$ ; for application diagram see Fig.11; unless otherwise specified.

SYMBOL	PARAMETER	CONDITIONS	MIN.	TYP.	MAX.	UNIT
<b>Supplies</b>						
$V_{CC}$	supply voltage		3.5	–	6	V
$I_{CC}$	supply current for operating mode on	note 1 $V_{PVD} = 0 \text{ V}$ ; $R_2 = 560 \Omega$	2.0	3.4	4.7	mA
	operating mode off	$V_{PVD} = V_{CC}$	–	3	30	$\mu\text{A}$
$V_{PVD(on)}$	PWD voltage for operating mode ON		0	–	300	mV
$V_{PVD(off)}$	PWD voltage for operating mode OFF		$V_{CC} - 0.3$	–	$V_{CC}$	V
$I_{PVD(on)}$	PWD current for operating mode ON	$V_{PVD} = 0 \text{ V}$	–30	–10	–3	$\mu\text{A}$
$I_{PVD(off)}$	PWD current for operating mode OFF	$V_{PVD} = V_{CC}$	–	1	3	$\mu\text{A}$
<b>Oscillator</b>						
$V_{OSC(DC)}$	DC operating point pin 4		3.28	3.34	3.40	V
<b>Mixer</b>						
$V_{MXIN(DC)}$	DC operating point pin 18		0.68	0.78	0.88	V
$V_{MOP(DC)}$	DC operating point pin 2		2.78	2.98	3.18	V
$V_{MON(DC)}$	DC operating point pin 1		2.78	2.98	3.18	V
<b>Post mixer amplifier</b>						
$V_{FA(DC)}$	DC operating point pin 20		2.14	2.27	2.40	V
<b>Limiter</b>						
$V_{LIN(DC)}$	DC operating point pin 17		3.45	3.49	3.50	V
$V_{LFB(DC)}$	DC operating point pin 16		2.76	2.81	2.86	V
$V_{RSSI(DC)}$	DC operating point pin 15		2.21	2.36	2.51	V
<b>Demodulator</b>						
$V_{DMOD(DC)}$	DC operating point pin 14		1.63	1.83	2.03	V
<b>Data slicer</b>						
$V_{CPC(DC)}$	DC operating point pin 13	note 2	1.43	1.93	2.43	V
$V_{CPA(DC)}$	DC operating point pin 10	note 2	1.43	1.93	2.43	V
$V_{CPB(DC)}$	DC operating point pin 9	note 2	1.43	1.93	2.43	V
$V_{OH(DAT)}$	HIGH-level data output voltage	$I_{DATA} = -10 \mu\text{A}$	$V_{CC} - 0.5$	–	$V_{CC}$	V
$V_{OL(DAT)}$	LOW-level data output voltage	$I_{DATA} = 200 \mu\text{A}$	0	–	0.6	V
<b>RSSI comparator</b>						
$V_{OH(RSSI)}$	HIGH-level comparator output voltage	$I_{RSSI} = -10 \mu\text{A}$	$V_{CC} - 0.5$	–	$V_{CC}$	V
$V_{OL(RSSI)}$	LOW-level comparator output voltage	$I_{RSSI} = 200 \mu\text{A}$	0	–	0.6	V

**Notes**

- The given values are valid for the whole temperature range from  $T_{amb} = -40$  to  $+85 \text{ }^\circ\text{C}$ .
- Tune RF input frequency until  $IF = 1 \text{ MHz}$ .

## Frequency Shift Keying (FSK) receiver

UAA3202M

**AC CHARACTERISTICS**

$V_{CC} = 3.5\text{ V}$ ;  $T_{amb} = 25\text{ }^{\circ}\text{C}$ ; for application diagram see Fig.11;  $f_i = 433.92\text{ MHz}$ ;  $\Delta f = \pm 25\text{ kHz}$ ;  $f_{mod} = 250\text{ Hz}$  square wave, i.e. 500 bits/s; unless otherwise specified.

SYMBOL	PARAMETER	CONDITIONS	MIN.	TYP.	MAX.	UNIT
<b>System performance</b>						
$P_{sens}$	sensitivity	$BER \leq 3\%$	–	–	–94	dBm
$P_{i(max)}$	maximum input power	$BER \leq 3\%$	–	–	–30	dBm
$\alpha_{rad}$	spurious radiation	note 1	–	–	–60	dBm
$t_{st}$	receiver settling time	$P_i = P_{sens} + 10\text{ dB}$ ; see Fig.5	–	2	5	ms
$B_{IF}$	IF bandwidth range	$P_i = P_{sens} + 3\text{ dB}$	850	1000	1150	kHz
$f_D$	data frequency		140	–	250	Hz
<b>Mixer</b>						
$G_{mix}$	mixer conversion gain		31	33	35	dB
$R_{o(mix)}$	mixer output resistance		2.7	3	3.3	k $\Omega$
<b>Post mixer amplifier</b>						
$IP3_{PMA}$	interception point (mixer + PMA)	note 2	–38	–35	–	dBm
$G_{PMA}$	PMA gain	note 2	9	10.4	12	dB
$P_{<1dB}$	compression (mixer + PMA)	$P_i = -45\text{ dBm}$	0	–	1	dBm
$BW_{PMA}$	PMA LP cut-off frequency		5	–	–	MHz
$R_{oPMA}$	PMA output resistance		1.2	1.4	1.6	k $\Omega$
<b>Limiter</b>						
$G_{lim}$	limiter gain		60	63.5	67	dB
$B_{lim}$	limiter LP cut-off frequency		2	5	8	MHz
$R_{i(lim)}$	limiter input resistance		40	50	60	k $\Omega$
<b>Demodulator</b>						
$G_{DMOD}$	demodulator gain	note 2	0.8	1	1.2	$\frac{mV}{kHz}$
$f_{c(DMOD)}$	demodulator centre frequency		800	1000	1200	kHz
$\Delta f$	frequency deviation		20	25	70	kHz
$R_{o(DMOD)}$	demodulator output resistance		24	30	36	k $\Omega$
<b>Data slicer</b>						
$B_{DS}$	data slicer bandwidth		35	50	–	kHz
$R_{o(DS)}$	data slicer output resistance		120	150	180	k $\Omega$
<b>RSSI comparator</b>						
$V_{o(RSSI)}$	RSSI output voltage	see Fig.3	–	–	–	–
$V_{o(COMP)}$	COMP output voltage	see Fig.4	–	–	–	–
$P_{th(on)}$	threshold for switching COMP output voltage to HIGH		–99.5	–95.5	–91.5	dBm
$P_{hys(W)}$	hysteresis width of COMP output voltage		1	2	4	dBm

**Notes**

1. Measured at the RF input connector of the test board.
2. Measured at test point A in Fig.11.

Frequency Shift Keying (FSK) receiver

UAA3202M

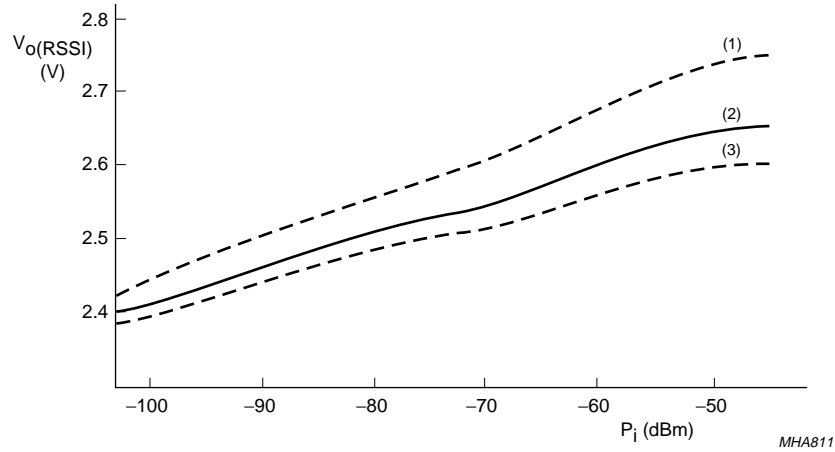

- (1)  $T_{\text{amb}} = 85^\circ\text{C}$ .
- (2)  $T_{\text{amb}} = 25^\circ\text{C}$ .
- (3)  $T_{\text{amb}} = -40^\circ\text{C}$ .

Fig.3 RSSI output voltage as a function of RF input power.

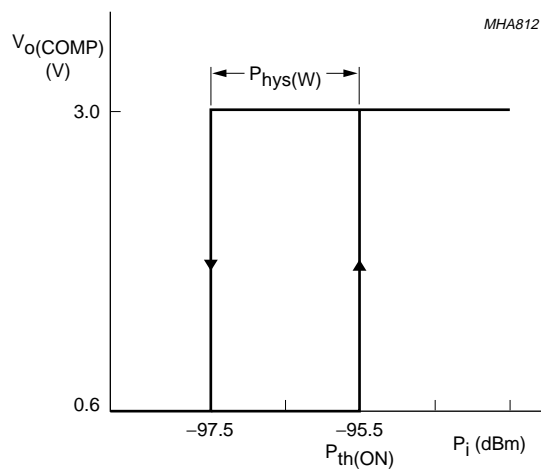

Fig.4 Comparator output voltage as a function of HF input power.

Frequency Shift Keying (FSK) receiver

UAA3202M

INTERNAL CIRCUITRY

Table 1 Equivalent pin circuits and pin voltages for rough test of printed circuit board;  $V_{CC} = 3.5\text{ V}$ ; no input signal

PIN	SYMBOL	DC VOLTAGE (V)	EQUIVALENT CIRCUIT
1	MON	2.98	
2	MOP	2.98	
3	$V_{CC}$	—	
4	OSC	3.34	
5	OSE	—	
6	$V_{EO}$	0	
7	$V_{EE}$	0	
8	COMP	—	
9	CPB	1.93	
10	CPA	1.93	

Frequency Shift Keying (FSK) receiver

UAA3202M

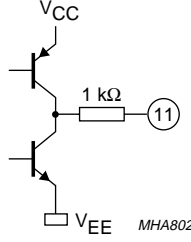
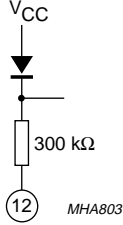
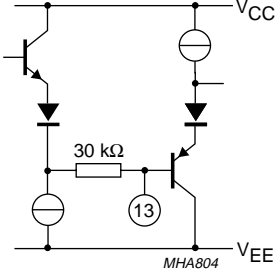
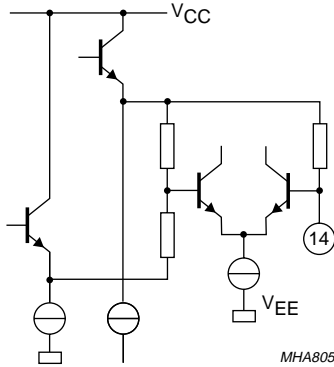
PIN	SYMBOL	DC VOLTAGE (V)	EQUIVALENT CIRCUIT
11	DATA	-	 <p style="text-align: right;"><i>MHA802</i></p>
12	PWD	-	 <p style="text-align: right;"><i>MHA803</i></p>
13	CPC	1.93	 <p style="text-align: right;"><i>MHA804</i></p>
14	DMOD	1.83	 <p style="text-align: right;"><i>MHA805</i></p>

Frequency Shift Keying (FSK) receiver

UAA3202M

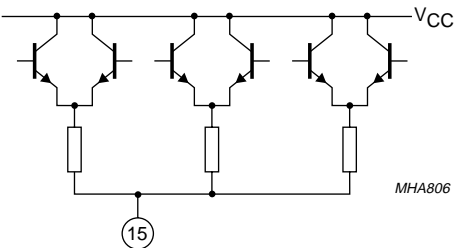
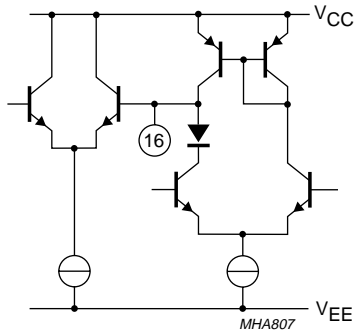
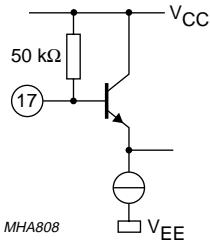
PIN	SYMBOL	DC VOLTAGE (V)	EQUIVALENT CIRCUIT
15	RSSI	2.36	
16	LFB	2.81	
17	LIN	3.49	

Frequency Shift Keying (FSK) receiver

UAA3202M

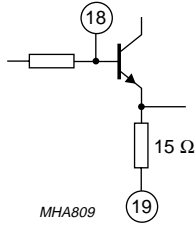
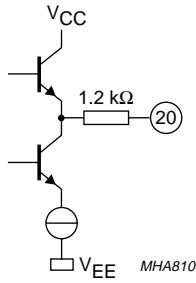
PIN	SYMBOL	DC VOLTAGE (V)	EQUIVALENT CIRCUIT
18	MXIN	0.78	
19	$V_{EM}$	0	
20	FA	2.27	

## Frequency Shift Keying (FSK) receiver

UAA3202M

## TEST INFORMATION

## Tuning procedure for AC tests

1. Turn on the signal generator ( $f_i = 433.92$  MHz; no modulation; RF input level =  $-60$  dBm).
2. Tune C6 (RF stage input) to obtain a peak voltage on test point A (see Fig.11).
3. Turn on modulation ( $f_i = 433.92$  MHz;  $f_{mod} = 250$  Hz square wave;  $\Delta f = 25$  kHz; RF input level =  $-60$  dBm).
4. Check that data is appearing on the data output (pin 11) and proceed with the AC tests.

## AC test conditions

Table 2 Test signals

The reference signal level  $P_{ref}$  for the following tests is defined as the minimum input level in dBm to give a  $BER \leq 3 \times 10^{-2}$  (e.g. 15 bit errors per second for 500 bits/s).

TEST SIGNAL	FREQUENCY (MHz)	DATA SIGNAL	MODULATION	FREQUENCY DEVIATION
1	433.92	250 Hz square wave	FM (FSK)	25 kHz
2	433.92	–	no modulation	–
3	433.82	–	no modulation	–

Table 3 Test results

$P_1$  is the maximum available power from signal generator 1 at the input of the test board;  $P_2$  is the maximum available power from signal generator 2 at the input of the test board.

TEST	GENERATOR		RESULT
	1	2	
Sensitivity into pin MXIN (see Fig.6)	modulated test signal 1; $P_1 \leq -94$ dBm	–	$BER \leq 3 \times 10^{-2}$ (e.g. 15 bit errors per second for 500 bits/s)
Maximum input power (see Fig.6)	modulated test signal 1; $P_1 \geq -30$ dBm (minimum $P_{max}$ )	–	$BER \leq 3 \times 10^{-2}$ (e.g. 15 bit errors per second for 500 bits/s)
Receiver turn-on time; note 1	test signal 1; $P_1 = P_{ref} + 10$ dB	–	check that the first 10 bits are correct; error counting is started 10 ms after PWD switched to operating mode: ON
Intercept point (mixer + PMA) see note 2 and Fig.7	test signal 3; $P_1 = -55$ dBm	test signal 2; $P_2 = P_1$	$IP3 = P_1 + \frac{1}{2} \times IM3$ (dB); $IP3 \geq -38$ dBm
Spurious radiation see note 3 and Fig.8	–	–	no spurious radiation (25 MHz – 1 GHz) with level higher than $-60$ dBm (maximum $P_{spur}$ )
1 dB compression point (mixer + PMA) see note 2 and Fig.9	test signal 3; $P_{11} = -70$ dBm; $P_{12} = -45$ dBm (minimum $P_{1dB}$ )	–	$(P_{o1} + 70$ dB) – $[P_{o2} + 45$ dB (minimum $P_{1dB}$ )] $\leq 1$ dB, where $P_{o1}$ , $P_{o2}$ is the output power for test signals with $P_{11}$ or $P_{12}$ , respectively

## Notes

1. The power-down voltage  $V_{PWD}$  alternates between operating mode ON (100 ms) and OFF (100 ms); see Fig.5.
2. Probe of spectrum analyzer connected to test point A.
3. Spectrum analyzer connected to the input of the test board.

Frequency Shift Keying (FSK) receiver

UAA3202M

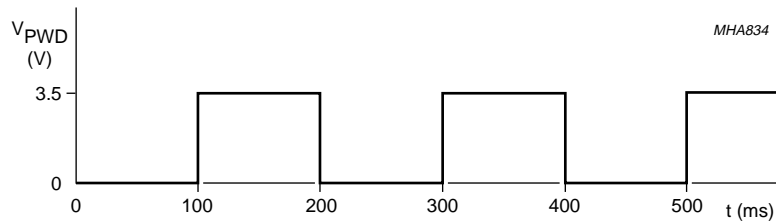
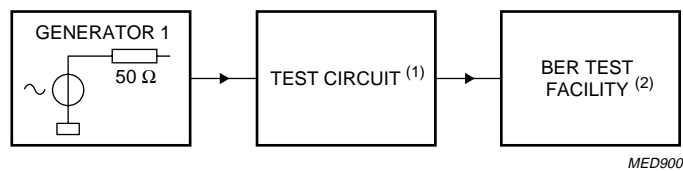
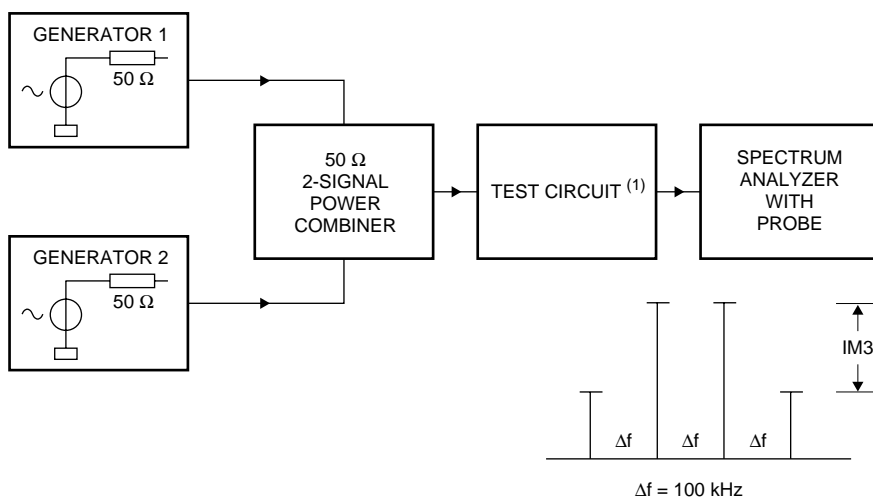

Fig.5 Timing diagram for pulsed power-down voltage.



- (1) For test circuit see Fig.11.
- (2) For BER test facility see Fig.10.

Fig.6 Test configuration A (single generator).



- (1) For test circuit see Fig.11.

Fig.7 Test configuration B (IP3).

Frequency Shift Keying (FSK) receiver

UAA3202M

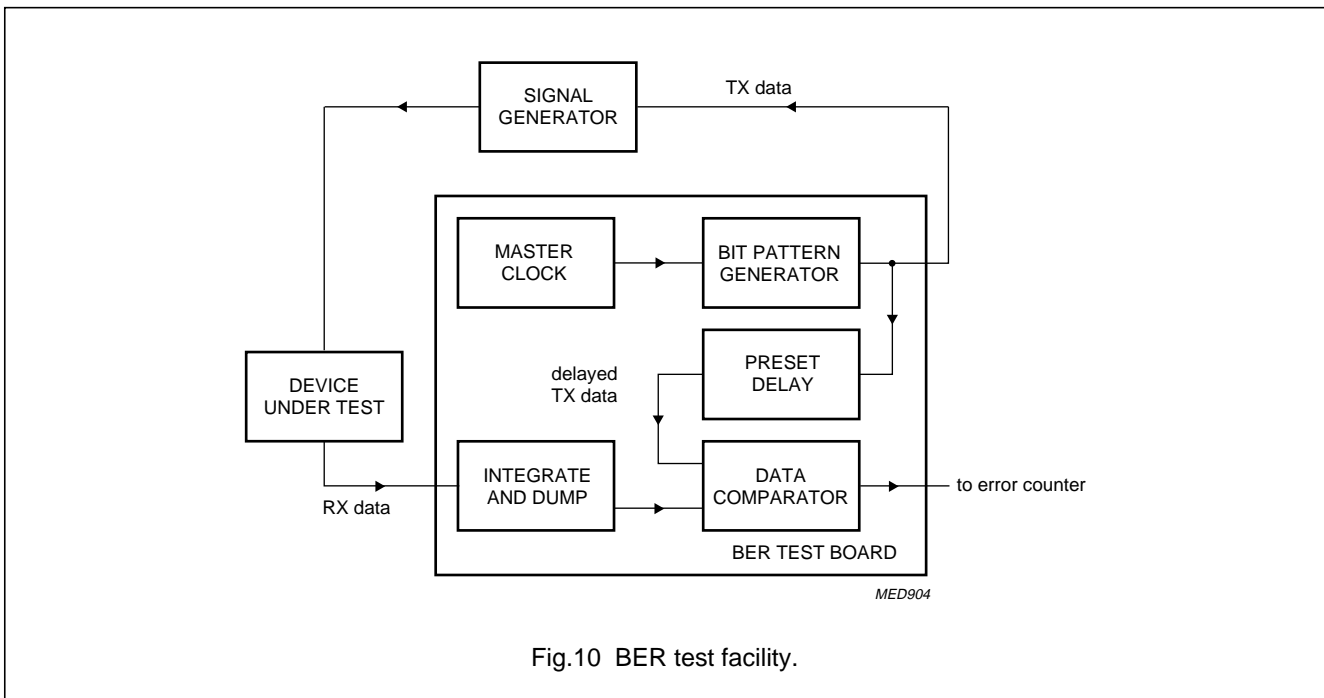
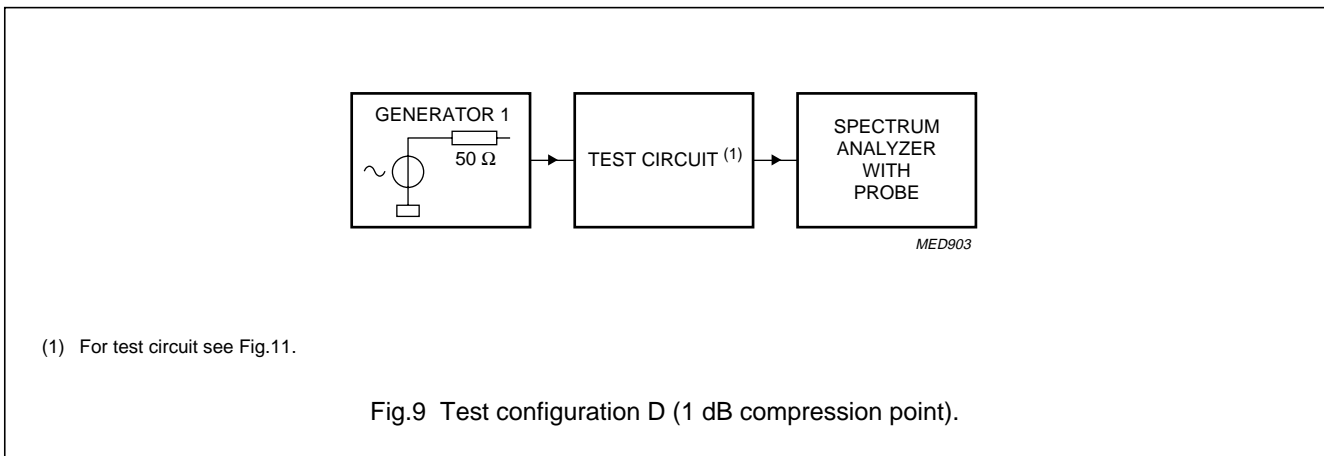
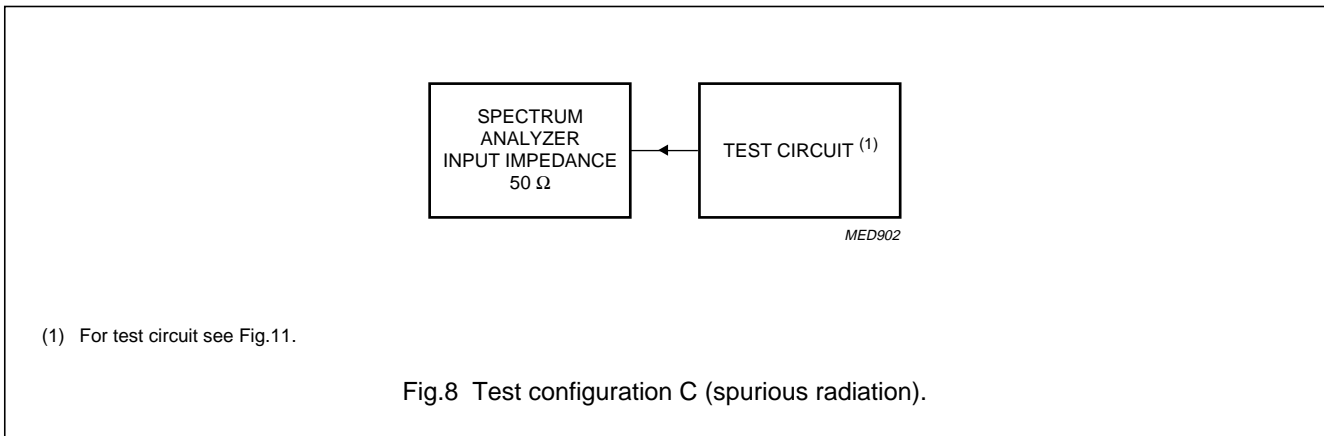

# Frequency Shift Keying (FSK) receiver

## UAA3202M

### APPLICATION INFORMATION

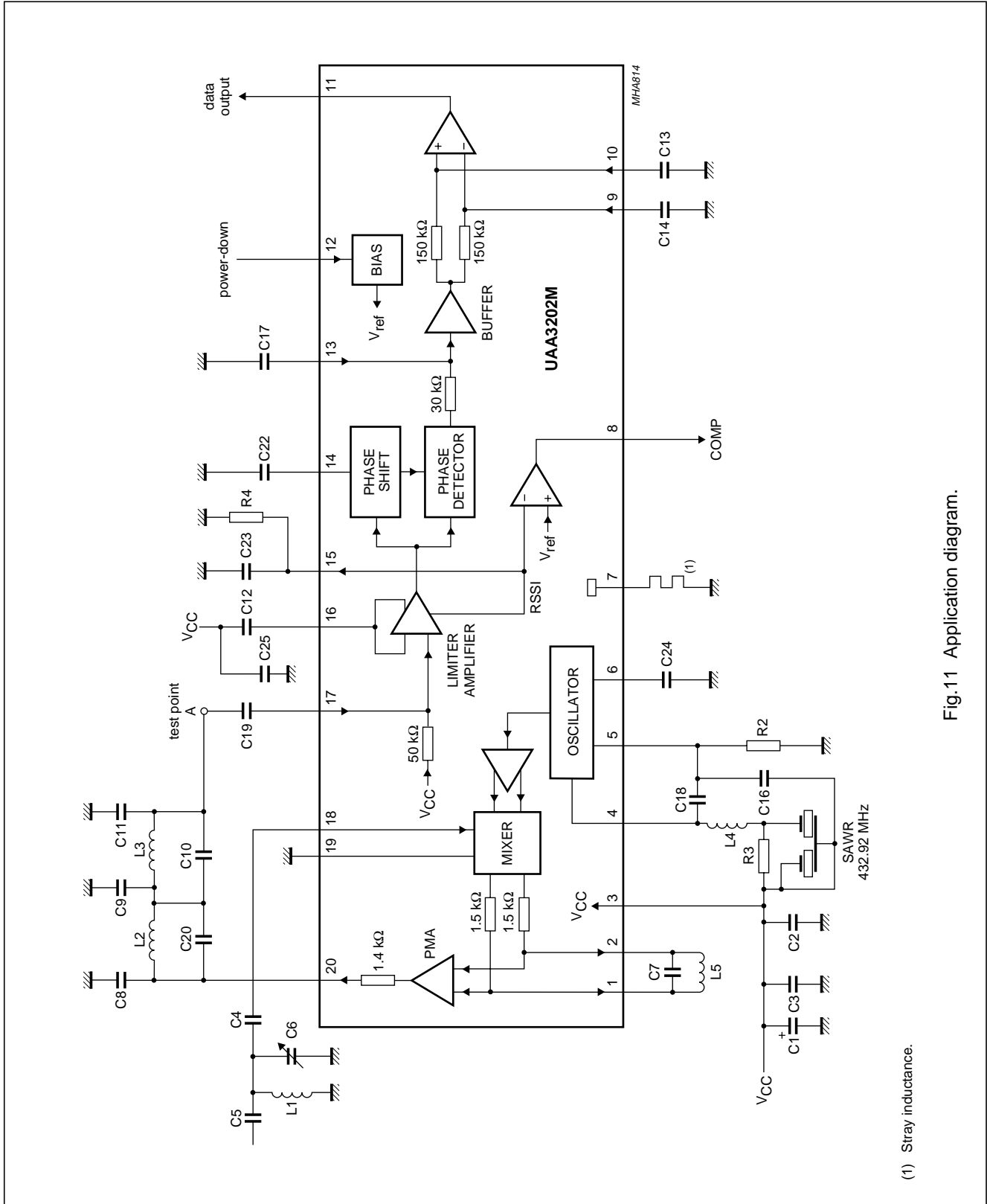

Fig.11 Application diagram.

(1) Stray inductance.

## Frequency Shift Keying (FSK) receiver

## UAA3202M

**Table 4** Application component list for Fig.11

COMPONENT	VALUE	TOLERANCE	DESCRIPTION
R2	560 $\Omega$	$\pm 2\%$	TC = 50 ppm/K
R3	220 $\Omega$	$\pm 2\%$	TC = 50 ppm/K
R4	820 k $\Omega$	$\pm 2\%$	TC = 50 ppm/K
C1	4.7 $\mu\text{F}$	$\pm 20\%$	–
C2	150 pF	$\pm 10\%$	TC = 0 $\pm 30$ ppm/K; $\tan \delta \leq 10 \times 10^{-4}$ ; f = 1 MHz
C3	100 nF	$\pm 10\%$	TC = 0 $\pm 30$ ppm/K; $\tan \delta \leq 10 \times 10^{-4}$ ; f = 1 MHz
C4	100 pF	$\pm 10\%$	TC = 0 $\pm 30$ ppm/K; $\tan \delta \leq 10 \times 10^{-4}$ ; f = 1 MHz
C5	2.7 pF	$\pm 10\%$	TC = 0 $\pm 150$ ppm/K; $\tan \delta \leq 30 \times 10^{-4}$ ; f = 1 MHz
C6	3 to 10 pF	–	TC = 0 $\pm 300$ ppm/K; $\tan \delta \leq 20 \times 10^{-4}$ ; f = 1 MHz
C7	56 pF	$\pm 10\%$	TC = 0 $\pm 30$ ppm/K; $\tan \delta \leq 10 \times 10^{-4}$ ; f = 1 MHz
C8	33 pF	$\pm 10\%$	TC = 0 $\pm 30$ ppm/K; $\tan \delta \leq 10 \times 10^{-4}$ ; f = 1 MHz
C9	100 pF	$\pm 10\%$	TC = 0 $\pm 30$ ppm/K; $\tan \delta \leq 10 \times 10^{-4}$ ; f = 1 MHz
C10	5.6 pF	$\pm 10\%$	TC = 0 $\pm 30$ ppm/K; $\tan \delta \leq 20 \times 10^{-4}$ ; f = 1 MHz
C11	100 pF	$\pm 10\%$	TC = 0 $\pm 30$ ppm/K; $\tan \delta \leq 10 \times 10^{-4}$ ; f = 1 MHz
C12	100 nF	$\pm 10\%$	$\tan \delta \leq 25 \times 10^{-3}$ ; f = 1 kHz
C13	2.2 nF	$\pm 10\%$	$\tan \delta \leq 25 \times 10^{-3}$ ; f = 1 kHz
C14	33 nF	$\pm 10\%$	$\tan \delta \leq 25 \times 10^{-3}$ ; f = 1 kHz
C16	3.9 pF	$\pm 10\%$	TC = 0 $\pm 150$ ppm/K; $\tan \delta \leq 30 \times 10^{-4}$ ; f = 1 MHz
C17	10 nF	$\pm 10\%$	$\tan \delta \leq 25 \times 10^{-3}$ ; f = 1 kHz
C18	1.8 pF	$\pm 10\%$	TC = 0 $\pm 150$ ppm/K; $\tan \delta \leq 30 \times 10^{-4}$ ; f = 1 MHz
C19	39 pF	$\pm 10\%$	TC = 0 $\pm 30$ ppm/K; $\tan \delta \leq 10 \times 10^{-4}$ ; f = 1 MHz
C20	3.3 pF	$\pm 10\%$	TC = 0 $\pm 150$ ppm/K; $\tan \delta \leq 30 \times 10^{-4}$ ; f = 1 MHz
C22	18 pF	$\pm 5\%$	TC = 0 $\pm 30$ ppm/K; $\tan \delta \leq 10 \times 10^{-4}$ ; f = 1 MHz
C23	47 nF	$\pm 10\%$	$\tan \delta \leq 25 \times 10^{-3}$ ; f = 1 kHz
C24	22 pF	$\pm 5\%$	TC = 0 $\pm 30$ ppm/K; $\tan \delta \leq 10 \times 10^{-4}$ ; f = 1 MHz
C25	1 nF	$\pm 10\%$	$\tan \delta \leq 25 \times 10^{-3}$ ; f = 1 kHz
L1	10 nH	$\pm 10\%$	$Q_{\min} = 50$ to 450 MHz; TC = 25 to 125 ppm/K
L2	150 $\mu\text{H}$	$\pm 10\%$	$Q_{\min} = 45$ to 800 kHz; $C_{\text{stray}} \leq 1$ pF
L3	220 $\mu\text{H}$	$\pm 10\%$	$Q_{\min} = 45$ to 800 kHz; $C_{\text{stray}} \leq 1$ pF
L4	33 nH	$\pm 10\%$	$Q_{\min} = 45$ to 450 MHz; TC = 25 to 125 ppm/K
L5	470 $\mu\text{H}$	$\pm 10\%$	$Q_{\min} = 45$ to 800 kHz; $C_{\text{stray}} \leq 1$ pF

**Table 5** Surface Acoustic Wave Resonator (SAWR) data

DESCRIPTION	SPECIFICATION
Type	one-port
Centre frequency	432.92 MHz $\pm 75$ kHz
Maximum insertion loss	1.5 dB
Typical loaded Q	1600 (50 $\Omega$ load)
Temperature drift	0.032 ppm/K <sup>2</sup>
Turnover temperature	43 $^{\circ}\text{C}$

# Frequency Shift Keying (FSK) receiver

# UAA3202M

## LAYOUT OF PRINTED-CIRCUIT BOARD FOR AC APPLICATION

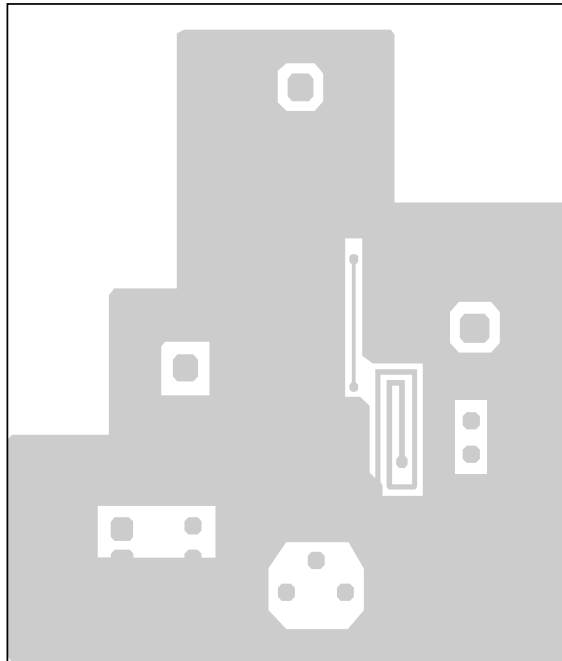

a. Copper side.

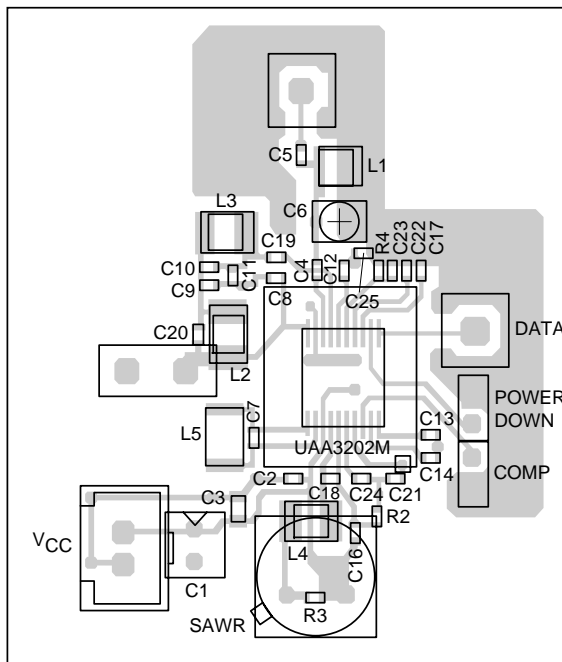

b. Component side.

MHA813

Fig.12 Printed-circuit board layout.

Frequency Shift Keying (FSK) receiver

UAA3202M

PACKAGE OUTLINE

SSOP20: plastic shrink small outline package; 20 leads; body width 5.3 mm

SOT339-1

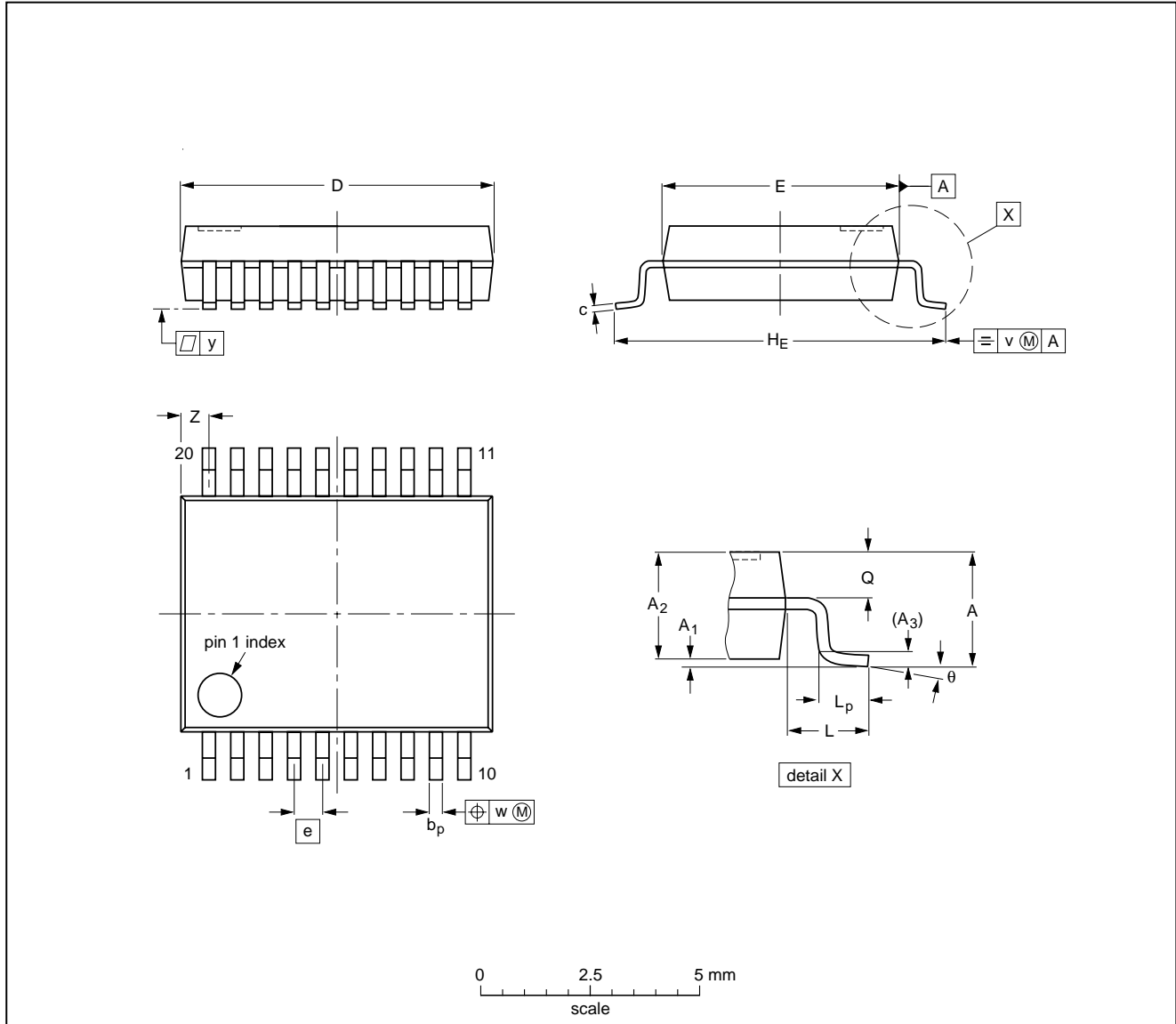

DIMENSIONS (mm are the original dimensions)

UNIT	A max.	A <sub>1</sub>	A <sub>2</sub>	A <sub>3</sub>	b <sub>p</sub>	c	D <sup>(1)</sup>	E <sup>(1)</sup>	e	H <sub>E</sub>	L	L <sub>p</sub>	Q	v	w	y	Z <sup>(1)</sup>	θ
mm	2.0	0.21 0.05	1.80 1.65	0.25	0.38 0.25	0.20 0.09	7.4 7.0	5.4 5.2	0.65	7.9 7.6	1.25	1.03 0.63	0.9 0.7	0.2	0.13	0.1	0.9 0.5	8° 0°

Note

1. Plastic or metal protrusions of 0.20 mm maximum per side are not included.

OUTLINE VERSION	REFERENCES				EUROPEAN PROJECTION	ISSUE DATE
	IEC	JEDEC	EIAJ			
SOT339-1		MO-150AE				93-09-08 95-02-04

---

## Frequency Shift Keying (FSK) receiver

UAA3202M

---

### SOLDERING

#### Introduction

There is no soldering method that is ideal for all IC packages. Wave soldering is often preferred when through-hole and surface mounted components are mixed on one printed-circuit board. However, wave soldering is not always suitable for surface mounted ICs, or for printed-circuits with high population densities. In these situations reflow soldering is often used.

This text gives a very brief insight to a complex technology. A more in-depth account of soldering ICs can be found in our "*IC Package Databook*" (order code 9398 652 90011).

#### Reflow soldering

Reflow soldering techniques are suitable for all SSOP packages.

Reflow soldering requires solder paste (a suspension of fine solder particles, flux and binding agent) to be applied to the printed-circuit board by screen printing, stencilling or pressure-syringe dispensing before package placement.

Several techniques exist for reflowing; for example, thermal conduction by heated belt. Dwell times vary between 50 and 300 seconds depending on heating method. Typical reflow temperatures range from 215 to 250 °C.

Preheating is necessary to dry the paste and evaporate the binding agent. Preheating duration: 45 minutes at 45 °C.

#### Wave soldering

Wave soldering is **not** recommended for SSOP packages. This is because of the likelihood of solder bridging due to closely-spaced leads and the possibility of incomplete solder penetration in multi-lead devices.

If wave soldering cannot be avoided, the following conditions must be observed:

- **A double-wave (a turbulent wave with high upward pressure followed by a smooth laminar wave) soldering technique should be used.**
- **The longitudinal axis of the package footprint must be parallel to the solder flow and must incorporate solder thieves at the downstream end.**

**Even with these conditions, only consider wave soldering SSOP packages that have a body width of 4.4 mm, that is SSOP16 (SOT369-1) or SSOP20 (SOT266-1).**

During placement and before soldering, the package must be fixed with a droplet of adhesive. The adhesive can be applied by screen printing, pin transfer or syringe dispensing. The package can be soldered after the adhesive is cured.

Maximum permissible solder temperature is 260 °C, and maximum duration of package immersion in solder is 10 seconds, if cooled to less than 150 °C within 6 seconds. Typical dwell time is 4 seconds at 250 °C.

A mildly-activated flux will eliminate the need for removal of corrosive residues in most applications.

#### Repairing soldered joints

Fix the component by first soldering two diagonally-opposite end leads. Use only a low voltage soldering iron (less than 24 V) applied to the flat part of the lead. Contact time must be limited to 10 seconds at up to 300 °C. When using a dedicated tool, all other leads can be soldered in one operation within 2 to 5 seconds between 270 and 320 °C.

---

**Frequency Shift Keying (FSK) receiver**
**UAA3202M**

---

**DEFINITIONS**

<b>Data sheet status</b>	
Objective specification	This data sheet contains target or goal specifications for product development.
Preliminary specification	This data sheet contains preliminary data; supplementary data may be published later.
Product specification	This data sheet contains final product specifications.
<b>Limiting values</b>	
Limiting values given are in accordance with the Absolute Maximum Rating System (IEC 134). Stress above one or more of the limiting values may cause permanent damage to the device. These are stress ratings only and operation of the device at these or at any other conditions above those given in the Characteristics sections of the specification is not implied. Exposure to limiting values for extended periods may affect device reliability.	
<b>Application information</b>	
Where application information is given, it is advisory and does not form part of the specification.	

**LIFE SUPPORT APPLICATIONS**

These products are not designed for use in life support appliances, devices, or systems where malfunction of these products can reasonably be expected to result in personal injury. Philips customers using or selling these products for use in such applications do so at their own risk and agree to fully indemnify Philips for any damages resulting from such improper use or sale.

Frequency Shift Keying (FSK) receiver

UAA3202M

---

**NOTES**

# Philips Semiconductors – a worldwide company

**Argentina:** see South America

**Australia:** 34 Waterloo Road, NORTH RYDE, NSW 2113,  
Tel. +61 2 9805 4455, Fax. +61 2 9805 4466

**Austria:** Computerstr. 6, A-1101 WIEN, P.O. Box 213, Tel. +43 160 1010,  
Fax. +43 160 101 1210

**Belarus:** Hotel Minsk Business Center, Bld. 3, r. 1211, Volodarski Str. 6,  
220050 MINSK, Tel. +375 172 200 733, Fax. +375 172 200 773

**Belgium:** see The Netherlands

**Brazil:** see South America

**Bulgaria:** Philips Bulgaria Ltd., Energoproject, 15th floor,  
51 James Bourchier Blvd., 1407 SOFIA,  
Tel. +359 2 689 211, Fax. +359 2 689 102

**Canada:** PHILIPS SEMICONDUCTORS/COMPONENTS,  
Tel. +1 800 234 7381

**China/Hong Kong:** 501 Hong Kong Industrial Technology Centre,  
72 Tat Chee Avenue, Kowloon Tong, HONG KONG,  
Tel. +852 2319 7888, Fax. +852 2319 7700

**Colombia:** see South America

**Czech Republic:** see Austria

**Denmark:** Prags Boulevard 80, PB 1919, DK-2300 COPENHAGEN S,  
Tel. +45 32 88 2636, Fax. +45 31 57 0044

**Finland:** Sinikalliontie 3, FIN-02630 ESPOO,  
Tel. +358 9 615800, Fax. +358 9 61580920

**France:** 4 Rue du Port-aux-Vins, BP317, 92156 SURESNES Cedex,  
Tel. +33 1 40 99 6161, Fax. +33 1 40 99 6427

**Germany:** Hammerbrookstraße 69, D-20097 HAMBURG,  
Tel. +49 40 23 53 60, Fax. +49 40 23 536 300

**Greece:** No. 15, 25th March Street, GR 17778 TAVROS/ATHENS,  
Tel. +30 1 4894 339/239, Fax. +30 1 4814 240

**Hungary:** see Austria

**India:** Philips INDIA Ltd, Band Box Building, 2nd floor,  
254-D, Dr. Annie Besant Road, Worli, MUMBAI 400 025,  
Tel. +91 22 493 8541, Fax. +91 22 493 0966

**Indonesia:** see Singapore

**Ireland:** Newstead, Clonskeagh, DUBLIN 14,  
Tel. +353 1 7640 000, Fax. +353 1 7640 200

**Israel:** RAPAC Electronics, 7 Kehilat Saloniki St, PO Box 18053,  
TEL AVIV 61180, Tel. +972 3 645 0444, Fax. +972 3 649 1007

**Italy:** PHILIPS SEMICONDUCTORS, Piazza IV Novembre 3,  
20124 MILANO, Tel. +39 2 6752 2531, Fax. +39 2 6752 2557

**Japan:** Philips Bldg 13-37, Kohnan 2-chome, Minato-ku, TOKYO 108,  
Tel. +81 3 3740 5130, Fax. +81 3 3740 5077

**Korea:** Philips House, 260-199 Itaewon-dong, Yongsan-ku, SEOUL,  
Tel. +82 2 709 1412, Fax. +82 2 709 1415

**Malaysia:** No. 76 Jalan Universiti, 46200 PETALING JAYA, SELANGOR,  
Tel. +60 3 750 5214, Fax. +60 3 757 4880

**Mexico:** 5900 Gateway East, Suite 200, EL PASO, TEXAS 79905,  
Tel. +9-5 800 234 7381

**Middle East:** see Italy

**Netherlands:** Postbus 90050, 5600 PB EINDHOVEN, Bldg. VB,  
Tel. +31 40 27 82785, Fax. +31 40 27 88399

**New Zealand:** 2 Wagener Place, C.P.O. Box 1041, AUCKLAND,  
Tel. +64 9 849 4160, Fax. +64 9 849 7811

**Norway:** Box 1, Manglerud 0612, OSLO,  
Tel. +47 22 74 8000, Fax. +47 22 74 8341

**Philippines:** Philips Semiconductors Philippines Inc.,  
106 Valero St. Salcedo Village, P.O. Box 2108 MCC, MAKATI,  
Metro MANILA, Tel. +63 2 816 6380, Fax. +63 2 817 3474

**Poland:** Ul. Lukiska 10, PL 04-123 WARSZAWA,  
Tel. +48 22 612 2831, Fax. +48 22 612 2327

**Portugal:** see Spain

**Romania:** see Italy

**Russia:** Philips Russia, Ul. Usatcheva 35A, 119048 MOSCOW,  
Tel. +7 095 755 6918, Fax. +7 095 755 6919

**Singapore:** Lorong 1, Toa Payoh, SINGAPORE 1231,  
Tel. +65 350 2538, Fax. +65 251 6500

**Slovakia:** see Austria

**Slovenia:** see Italy

**South Africa:** S.A. PHILIPS Pty Ltd., 195-215 Main Road Martindale,  
2092 JOHANNESBURG, P.O. Box 7430 Johannesburg 2000,  
Tel. +27 11 470 5911, Fax. +27 11 470 5494

**South America:** Rua do Rocio 220, 5th floor, Suite 51,  
04552-903 São Paulo, SÃO PAULO - SP, Brazil,  
Tel. +55 11 821 2333, Fax. +55 11 829 1849

**Spain:** Balmes 22, 08007 BARCELONA,  
Tel. +34 3 301 6312, Fax. +34 3 301 4107

**Sweden:** Kottbygatan 7, Akalla, S-16485 STOCKHOLM,  
Tel. +46 8 632 2000, Fax. +46 8 632 2745

**Switzerland:** Allmendstrasse 140, CH-8027 ZÜRICH,  
Tel. +41 1 488 2686, Fax. +41 1 481 7730

**Taiwan:** Philips Semiconductors, 6F, No. 96, Chien Kuo N. Rd., Sec. 1,  
TAIPEI, Taiwan Tel. +886 2 2134 2865, Fax. +886 2 2134 2874

**Thailand:** PHILIPS ELECTRONICS (THAILAND) Ltd.,  
209/2 Sanpavuth-Bangna Road Prakanong, BANGKOK 10260,  
Tel. +66 2 745 4090, Fax. +66 2 398 0793

**Turkey:** Talatpasa Cad. No. 5, 80640 GÜLTEPE/ISTANBUL,  
Tel. +90 212 279 2770, Fax. +90 212 282 6707

**Ukraine:** PHILIPS UKRAINE, 4 Patrice Lumumba str., Building B, Floor 7,  
252042 KIEV, Tel. +380 44 264 2776, Fax. +380 44 268 0461

**United Kingdom:** Philips Semiconductors Ltd., 276 Bath Road, Hayes,  
MIDDLESEX UB3 5BX, Tel. +44 181 730 5000, Fax. +44 181 754 8421

**United States:** 811 East Arques Avenue, SUNNYVALE, CA 94088-3409,  
Tel. +1 800 234 7381

**Uruguay:** see South America

**Vietnam:** see Singapore

**Yugoslavia:** PHILIPS, Trg N. Pasica 5/v, 11000 BEOGRAD,  
Tel. +381 11 625 344, Fax. +381 11 635 777

**For all other countries apply to:** Philips Semiconductors, Marketing & Sales Communications,  
Building BE-p, P.O. Box 218, 5600 MD EINDHOVEN, The Netherlands, Fax. +31 40 27 24825

**Internet:** <http://www.semiconductors.philips.com>

© Philips Electronics N.V. 1997

SCA55

All rights are reserved. Reproduction in whole or in part is prohibited without the prior written consent of the copyright owner.

The information presented in this document does not form part of any quotation or contract, is believed to be accurate and reliable and may be changed without notice. No liability will be accepted by the publisher for any consequence of its use. Publication thereof does not convey nor imply any license under patent- or other industrial or intellectual property rights.

Printed in The Netherlands

547027/1200/01/pp24

Date of release: 1997 Aug 12

Document order number: 9397 750 02306

*Let's make things better.*

**Philips  
Semiconductors**



**PHILIPS**