

## Rear Wiper Interval/Wipe-Wash Control

### Description

The bipolar integrated circuit, U690B, is designed with a time coded input for the rear pane wiper application. The length of the input signal determines the mode of

operation i.e., intermittent or wipe/ wash; therefore, only one signal line is sufficient from the input switch to the electronic module.

### Features

- Time controlled interval/ wipe-wash
- Wiper arm's park position control
- Interval pause typ. 7 s
- Dry wiping time typ. 4.4 s
- Multipurpose frequency comparator
- Relay driver with Z-diode
- RC-oscillator determines switching characteristics
- Debounced main signal input
- Power-on reset by low-voltage identification
- Protection according to ISO / TR 7637-1 (VDE 0839)
- Load-dump protection

### Applications

Speed or R.P.M. detection

### Ordering Information

Extended Type Number	Package	Remarks
U690B	DIP8	

### Pin Configuration

Pin	Symbol	Function
1	GND	Ground
2	Output	Relay control output
3	Input	Signal input
4	Retrigger	Retrigger
5	Program	Program input
6	OSC	RC-oscillator
7	Hyst	Hysteresis output
8	V <sub>stab</sub>	Supply voltage 7.3 V

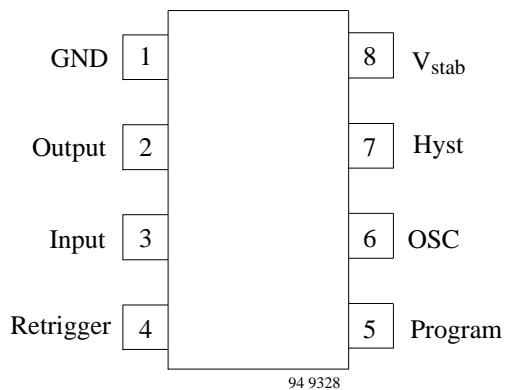

Figure 4. Pinning

## Block Diagram

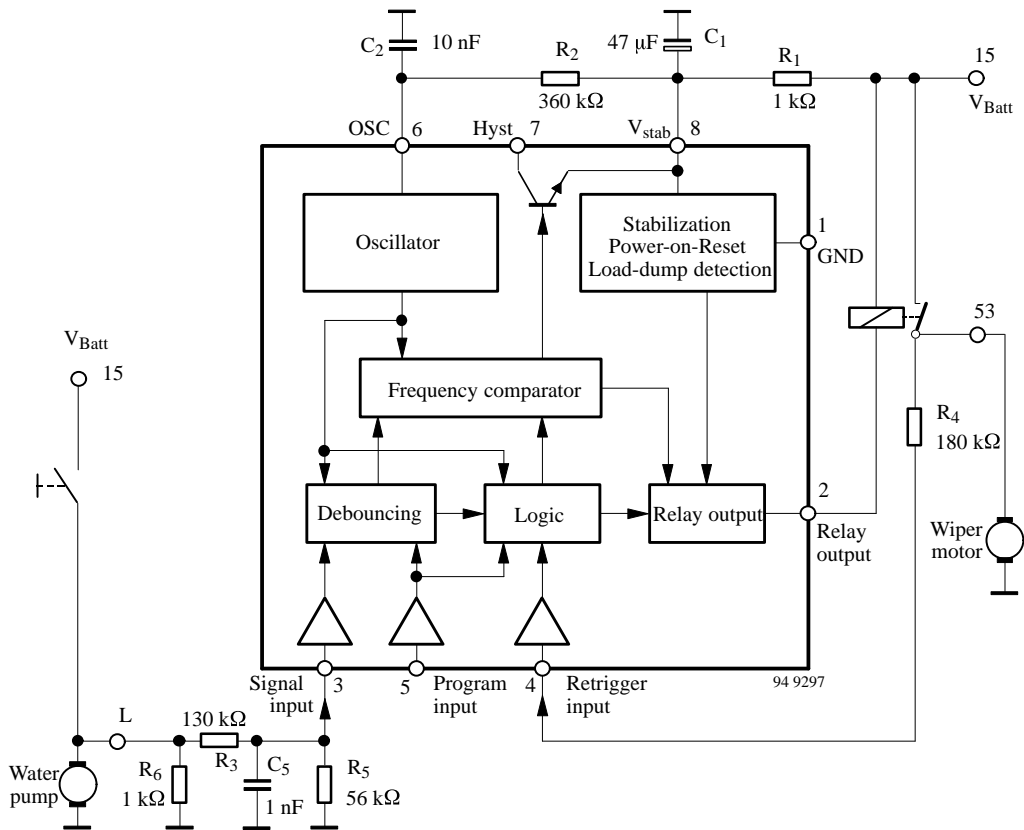

Figure 1. Application circuit for rear wiper interval/wipe-wash control

## Functional Description

### Power Supply, Pin 8

For reasons of interference protection and surge immunity, the supply voltage (Pin 8) must be provided with an RC-circuit as shown in figure 2. Dropper resistor,  $R_1$ , limits the current in case of overvoltage, whereas  $C_1$  smoothes the supply voltage at Pin 8.

Recommended values are:  $R_1 = 1 \text{ k}\Omega$ ,  $C_1 = 47 \text{ }\mu\text{F}$ .

An integrated Z-diode (7.3 V) generates the stabilized voltage,  $V_{stab}$ , therefore, the operation of the IC is possible between 6 V and 16 V, supplied by  $V_{Batt}$  (Terminal 15).

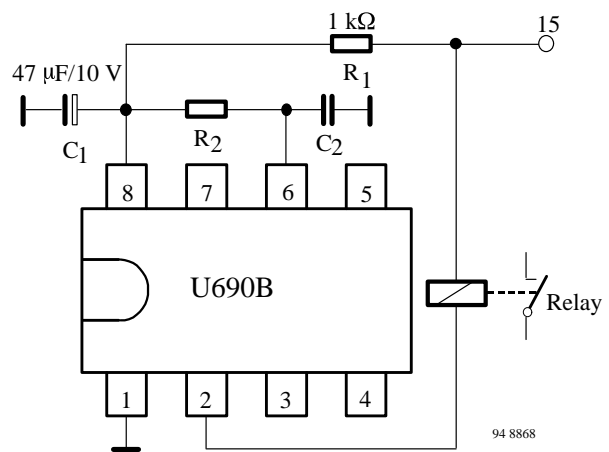

Figure 2. Basic circuitry

## Interference Voltages and Load-Dump, Pins 3 and 4

Pin 3 (signal input) and Pin 4 (retrigger input) are protected against short interference peaks via the integrated Z-diodes and external series resistance.

## Relay Control Output, Pin 2

The relay control output is an open collector Darlington circuit with an integrated 21-V Z-diode for limitation of the inductive cut-off pulse of the relay coil. The maximum static collector current must not exceed 200 mA and the saturation voltage is typically 1.0 V @ 100 mA, whereas the typical resistive load is 80 Ω.

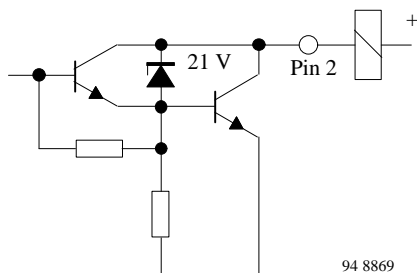

Figure 3. Relay control output

## Oscillator, Pin 6

Oscillator frequency,  $f$ , is determined mainly by the  $R_2C_2$  circuit. The resistance,  $R_2$ , determines the charge time, and the integrated resistance (2 kΩ) is responsible for discharge time. For the stability of the oscillator frequency, it is recommended that the selected  $R_2$  value be much greater than the internal resistance (2 kΩ), because the temperature response and the tolerances of the integrated resistance are considerably greater than the external resistance value.

Oscillator frequency,  $f$ , is calculated as follows:

$$f = 1/C_2 \cdot (0.632 \cdot R_2 + 1900)$$

Minimum value for  $R_2 = 68 \text{ k}\Omega$

Maximum oscillator frequency is 20 kHz.

For further information, please refer to table 1, regarding relationship between oscillator frequency and different timings.

## Rear Wiper Interval/Wipe-Wash Control, Figures 1 and 4

A single high-side switch at terminal L is responsible for all switching sequences. The water pump motor is con-

nected at terminal L and the wiper motor is connected at terminal 53, as shown in figure 1.

Figure 4 shows three different modes of operation. The input signal pulse width,  $t_p$ , (see figure 1, terminal L) determines the operation mode, with an assumed oscillator frequency of  $f = 400 \text{ Hz}$ . Pin 5 and Pin 7 are open. As a debouncing measure, input pulses of  $t_p$  less than 50 ms do not activate the relay.

Further explanation is given with typical values. For detailed information, please refer to table 1.

- Interval mode:  $50 \text{ ms} \leq t_p \leq 610 \text{ ms}$   
Pin 2 (relay control output) is activated for 640 ms, where the interval pause,  $t_3$ , is approximately 7 s.
- Wipe/wash mode:  $t_p \geq 610 \text{ ms}$   
Dry wiping time is 4.4 s after the negative edge of  $t_p$ .
- Wipe/wash mode with retrigger

## Retriggering for Large Park Segment

After dry wiping, the slip ring contact cuts off the supply of the wiper motor and stops the wiper in its parking position.

However due to mechanical tolerances, the contact may pass over the park segment so that the wiper is switched off by the relay. The wiper arm then stops at an undefined position on the screen.

By retriggering the U690B prevents the wiper arm from stopping anywhere other than its parking position. The voltage of the relay contact is fed back to the retrigger input which detects the negative switch off pulse (see figure 4) and reactivates the wiper motor immediately for approximately 640 ms. After another turn, the wiper is switched off correctly via the slip ring contact.

The interval mode can be activated during the dry wiping time, but the retriggering mode is switched-off during this time.

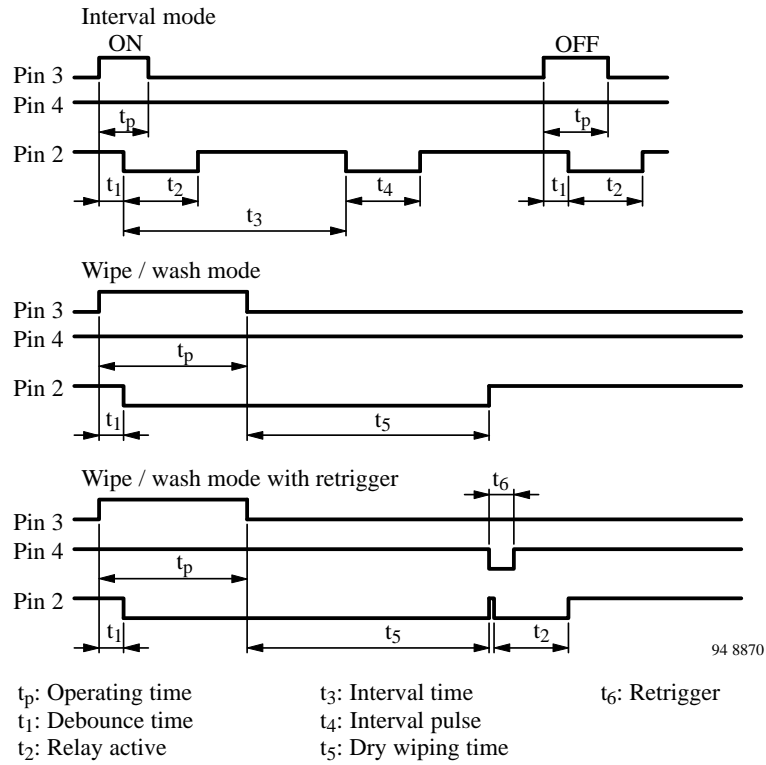

Figure 4. Pulse diagram for different modes – wipe/wash

Table 1. Time for rear wiper interval operation

Index t	Description	Oscillator Clocks
1	Interval ON (first pulse)	252
2	Interval ON (following pulses)	256
3	Interval pause (except first pause)	2816
4	Pause (dry wiping interval pulse)	1024
5	Dry wiping time min/max	1738/1810
6	Gate for retrigger	8
7	Min/max lengthening at retrigger	248/256
8	Debounce time min/max	16/24
9	Recognition time for dry wiping min/max	240/248

f <sub>osc</sub> (Hz)	1 (ms)	2 (ms)	3 (s)	4 (s)	5 <sub>min</sub> 5 <sub>max</sub> (s)	6 (ms)	7 <sub>min</sub> 7 <sub>max</sub> (ms)	8 <sub>min</sub> 8 <sub>max</sub> (ms)	9 <sub>min</sub> 9 <sub>max</sub> (ms)
300	840	853	9.387	3.410	5.790 6.030	27	827 853	53 80	800 827
310	813	826	9.084	3.300	5.603 5.835	26	800 826	52 77	774 800
320	788	800	8.800	3.197	5.428 5.653	25	775 800	50 75	750 775
330	764	776	8.533	3.100	5.264 5.482	24	752 776	48 73	727 752
340	741	753	8.282	3.009	5.109 5.321	24	729 753	47 71	706 729
350	720	731	8.064	2.923	4.963 5.169	23	709 731	46 69	686 709
360	700	711	7.822	2.842	4.825 5.025	22	689 711	44 67	667 689
370	681	692	7.611	2.765	4.695 4.889	22	670 692	43 65	649 670
380	663	674	7.411	2.692	4.571 4.761	21	653 674	42 63	632 653
390	646	656	7.221	2.623	4.454 4.638	21	636 656	41 62	615 636
400	630	640	7.040	2.558	4.343 4.523	20	620 640	40 60	600 620
410	615	624	6.868	2.495	4.237 4.412	20	605 624	39 59	585 605
420	600	610	6.705	2.436	4.136 4.307	19	590 610	38 57	571 590
430	586	595	6.549	2.379	4.040 4.207	19	577 595	37 56	558 577
440	573	582	6.400	2.325	3.948 4.111	18	564 582	36 55	545 564
450	560	569	6.258	2.273	3.860 4.020	18	551 569	36 53	533 551
460	548	557	6.122	2.224	3.776 3.933	17	539 557	35 52	522 539
470	536	545	5.991	2.177	3.696 3.849	17	528 545	34 51	511 528
480	525	533	5.867	2.131	3.619 3.769	17	517 533	33 50	500 517
490	514	522	5.747	2.088	3.545 3.692	16	506 522	33 49	490 506
500	504	512	5.632	2.046	3.474 3.618	16	496 512	32 48	480 496

## Absolute Maximum Ratings

Reference point Pin 1 (31), unless otherwise specified

Parameters	Symbol	Value	Unit
Operating voltage, static 5 min., Terminal 15	$V_{Batt}$	24	V
Ambient temperature range	$T_{amb}$	-40 to +95	°C
Storage temperature range	$T_{stg}$	-55 to +125	°C
Junction temperature	$T_j$	150	°C

## Thermal Resistance

Parameters	Symbol	Value	Unit
Junction ambient DIP 8	$R_{thJA}$	110	K/W

## Electrical Characteristics

Reference point Ground (Pin 1),  $T_{amb} = 25^{\circ}\text{C}$ ,  $V_{Batt} = 12\text{ V}$ , unless otherwise specified, see basic circuitry figure 2

Parameters	Test Conditions / Pin	Symbol	Min	Typ	Max	Unit
Operating voltage	$R_1 \geq 1\text{ k}\Omega$ $t < 5\text{ min}$ $t < 60\text{ min}$	$V_{Batt}$	6.0		16.0 24.0 18.0	V
Stabilized voltage	$I_8 = 10\text{ mA}$ Pin 8	$V_8$		7.35		V
Low voltage detection	Terminal 15	$V_{Batt}$	4.0	4.5	5.0	V
<b>Relay control output</b> Pin 2						
Saturation voltage	$I \leq 200\text{ mA}$ $I \leq 100\text{ mA}$	$V_2$			1.5 1.2	V
Internal Z-diode	$I_2 = 10\text{ mA}$ Pin 2	$V_z$	20	21	23	V
<b>Oscillator</b> $f = 0.001\text{ to }20\text{ kHz}$ Pin 6						
Integrated discharge resistor	$V_6 = V_8$	$r_6$	1.6	2.0	2.4	k $\Omega$
Switching threshold voltage	lower upper	$V_{6L}$ $V_{6H}$		1.8 4.6		V
Input current	$V_6 = 0\text{ V}$	$-I_6$			1	$\mu\text{A}$
Hysteresis current	Pin 7	$-I_7$			200	$\mu\text{A}$
Saturation voltage	$I_7 = -100\text{ }\mu\text{A}$ Pin 7	$V_{7-8}$		100	200	mV
<b>Programming input</b> Pin 5						
Pull-up resistor		$r_5$	40	50	60	k $\Omega$
Temperature drift of $r_5$		TC		0.45		%/deg.
Switching threshold voltage		$V_5$		2		V
<b>Signal input,</b> $R_3 = 1\text{ k}\Omega$ (min), fig.1, Pin 3						
Input current	$V_3 = 2\text{ V}$	$-I_3$			0.5	$\mu\text{A}$
Threshold voltage	ON OFF	$V_3$	2.1 1.6		2.3 1.8	V
Internal Z-diode	$I_3 = 10\text{ mA}$ $I_3 = -10\text{ mA}$	$V_3$ $-V_3$		7.5 0.7		V
<b>Retrigger</b> $R_4 = 1\text{ k}\Omega$ (min), fig. 1, Pin 4						
Threshold voltage	ON OFF	$V_4$	2.1 1.6		2.3 1.8	V
Internal Z-diode	$I_4 = 10\text{ mA}$ $I_4 = -10\text{ mA}$	$V_4$ $-V_4$		7.5 0.7		V
Integrated pull-up resistor		$r_4$	40	50	60	k $\Omega$
Temperature drift of $r_4$		TC		0.45		%/deg.

**Applications**

**Frequency Comparator**

**Speed Depending Switch with Hysteresis, Figure 5**

This circuit can be used to activate a load, such as a warning lamp or buzzer via the relay (terminal A) at a certain speed. The speed information is applied to signal input, Pin 3, e.g. from Hall generator via terminal V.

It is compared in the integrated circuit with a reference frequency created by the oscillator. The oscillator frequency,  $f$ , is generated with external resistor,  $R_2 \parallel R_7$ , and capacitor,  $C_2$ .

If the frequency at Pin 3 is less than  $f/64$ , the relay control output is deactivated.

If the frequency at Pin 3 is greater than  $f/64$ , the relay control output is activated and at the same time the hysteresis output, Pin 7, is disabled, the frequency is reduced. This means Pin 7 supplies no current for charging the capacitor,  $C_2$ ; therefore,  $R_2$  and  $C_2$  alone define the oscillator frequency i.e.,  $f \approx R_2 \cdot C_2$ .

The hysteresis frequency is determined with the resistor,  $R_7$ .

**Motor Speed Depending Switch with Hysteresis, Figure 6**

This circuit, figure 6, has the same function as the speed with hysteresis mentioned above.

Information regarding motor speed (rpm) from the ignition coil is delivered to signal input, Pin 3, via terminal 1. Resistor values,  $R_3$  and  $R_5$  are so dimensioned, that there is a peak voltage of nearly 3 V at Pin 3 (from the ignition coil). Pin 4 is connected to GND, so that there is a bypass for debouncing. In this way, ignition pulse is supplied to frequency comparator.

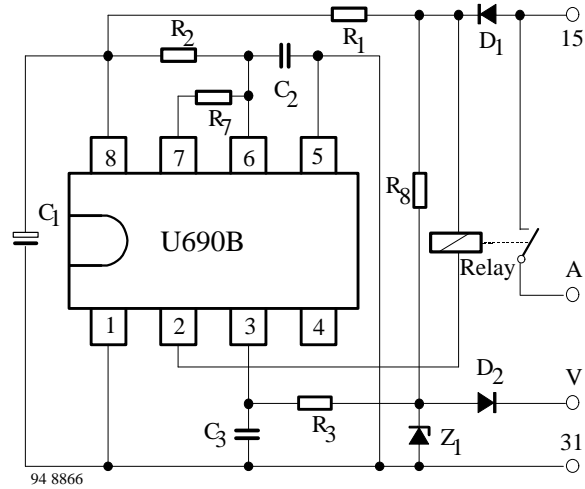

Figure 5. Speed switch

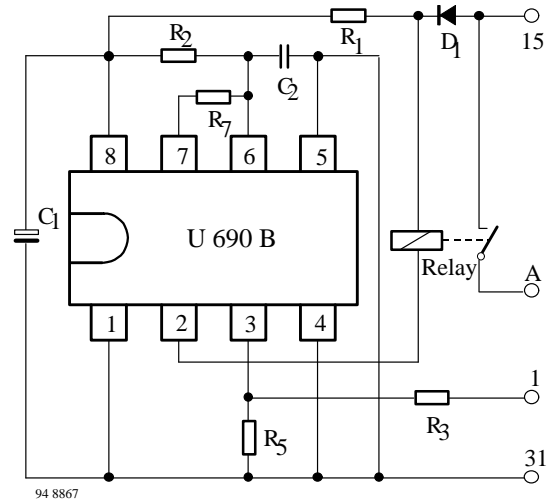
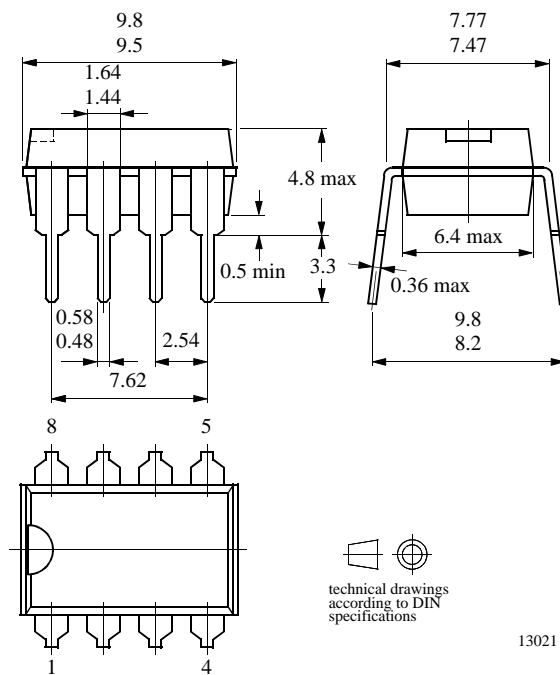

Figure 6. Motor speed switch with hysteresis

## Package Information

Package DIP8

Dimensions in mm



## Ozone Depleting Substances Policy Statement

It is the policy of **TEMIC TELEFUNKEN microelectronic GmbH** to

1. Meet all present and future national and international statutory requirements.
2. Regularly and continuously improve the performance of our products, processes, distribution and operating systems with respect to their impact on the health and safety of our employees and the public, as well as their impact on the environment.

It is particular concern to control or eliminate releases of those substances into the atmosphere which are known as ozone depleting substances (ODSs).

The Montreal Protocol (1987) and its London Amendments (1990) intend to severely restrict the use of ODSs and forbid their use within the next ten years. Various national and international initiatives are pressing for an earlier ban on these substances.

**TEMIC TELEFUNKEN microelectronic GmbH** semiconductor division has been able to use its policy of continuous improvements to eliminate the use of ODSs listed in the following documents.

1. Annex A, B and list of transitional substances of the Montreal Protocol and the London Amendments respectively
2. Class I and II ozone depleting substances in the Clean Air Act Amendments of 1990 by the Environmental Protection Agency (EPA) in the USA
3. Council Decision 88/540/EEC and 91/690/EEC Annex A, B and C (transitional substances) respectively.

**TEMIC** can certify that our semiconductors are not manufactured with ozone depleting substances and do not contain such substances.

**We reserve the right to make changes to improve technical design and may do so without further notice.**

Parameters can vary in different applications. All operating parameters must be validated for each customer application by the customer. Should the buyer use TEMIC products for any unintended or unauthorized application, the buyer shall indemnify TEMIC against all claims, costs, damages, and expenses, arising out of, directly or indirectly, any claim of personal damage, injury or death associated with such unintended or unauthorized use.

TEMIC TELEFUNKEN microelectronic GmbH, P.O.B. 3535, D-74025 Heilbronn, Germany  
Telephone: 49 (0)7131 67 2831, Fax number: 49 (0)7131 67 2423