

Description

The μPD449 is a high-speed, low-power, 2048-word by 8-bit static CMOS RAM fabricated with advanced silicon-gate CMOS technology. A unique circuitry technique makes the μPD449 a very low operating power device which requires no clock or refreshing to operate. Since the device has two chip enable inputs, it is suited for battery backup applications. Minimum standby power current is drawn by this device when \overline{CE}_1 or \overline{CE}_2 equals V_{CC} independently of the other input levels. Data retention is guaranteed at a power supply voltage as low as 2V.

The μPD449 has a standard 24-pin dual-in-line package and is plug-in compatible with 16K EPROMs.

Features

- Single +5 V supply
- Fully static operation — no clock or refreshing required
- TTL compatible — all inputs and outputs
- Common I/O using three-state output
- Two chip enable inputs for battery backup application
- Max access/min cycle times down to 150 ns
- Low power dissipation,
 - Active: 38 mA max
 - Standby: 10 μA max
- Data retention voltage: 2 V min
- Operating temperature range: - 40 to +85°C
- Standard 24-pin plastic package
- Plug-in compatible with 16K EPROMs
- L version
 - Standby current 1.0 μA max at 60°C for battery backup operation

Pin Configuration

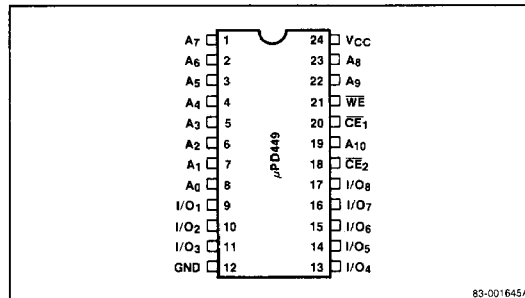

Pin Identification

No.	Symbol	Function
1-8, 19, 22, 23	A ₀ -A ₁₀	Address input
9-11, 13-17	I/O ₁ -I/O ₈	Data input/output
20, 18	$\overline{CE}_1, \overline{CE}_2$	Chip enable input
21	\overline{WE}	Write enable input
24	V _{CC}	Power (+5 V)
12	GND	GND

Performance Ranges

Device	Access Time (Max)	Cycle Time (Min)	Power Supply (Max)	
			Active	Standby
μPD449C-3	150 ns	150 ns	38 mA	(Note 1)
μPD449C-2	200 ns	200 ns	30 mA	(Note 1)
μPD449C-1	250 ns	250 ns	26 mA	(Note 1)
μPD449C	450 ns	450 ns	18 mA	(Note 1)

Note:

(1) μPD449C-L/-1L/-2L/-3L

T_A = 25°C, 0.2 μA

T_A = 60°C, 1.0 μA

T_A = 85°C, 10 μA

μPD449C/-1/-2/-3

T_A = 25°C, 1.0 μA

T_A = 60°C, 5.0 μA

T_A = 85°C, 10 μA



Block Diagram

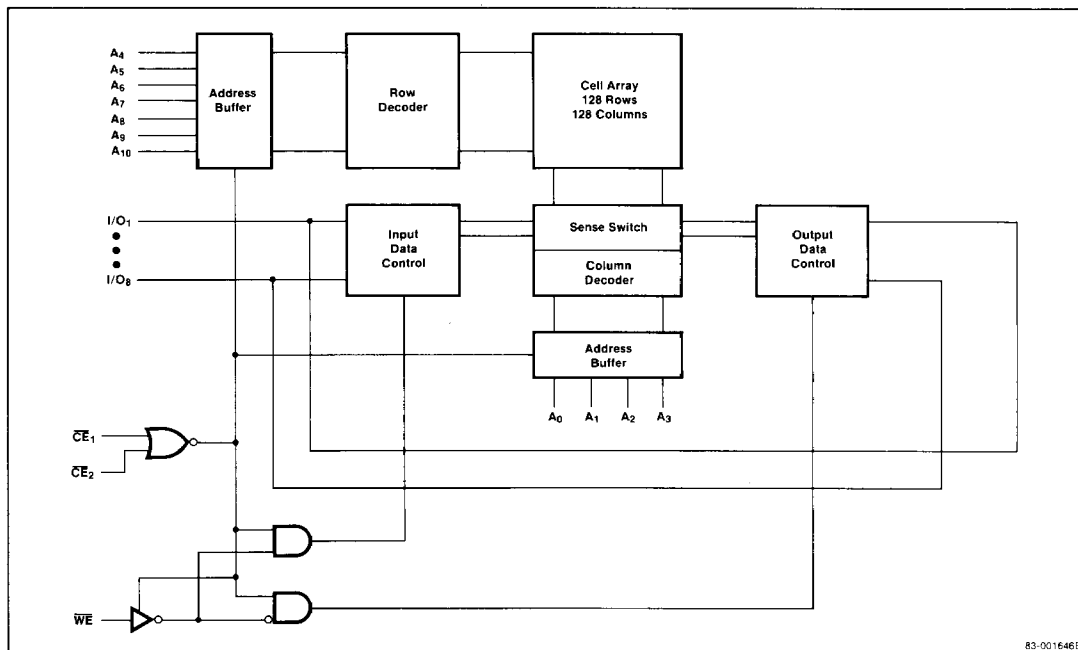

83-001646B

Absolute Maximum Ratings

Power supply voltage, V_{CC}	7.0 V
Input voltage, V_{IN}	-0.3 to $V_{CC} + 0.3$ V
Output voltage, V_{OUT}	-0.3 to $V_{CC} + 0.3$ V
Operating temperature, T_{OPR}	-40 to +85°C
Storage temperature, T_{STG}	-55 to +125°C

Comment: Exposing the device to stresses above those listed in Absolute Maximum Ratings could cause permanent damage. The device is not meant to be operated under conditions outside the limits described in the operational sections of the specification. Exposure to absolute maximum rating conditions for extended periods may affect device reliability.

Capacitance

$T_A = 25^\circ\text{C}$, $f = 1$ MHz

Parameter	Symbol	Limits			Unit	Test Conditions
		Min	Typ	Max		
Input capacitance	C_{IN}			6	pF	$V_{IN} = 0$ V
Input/output capacitance	$C_{I/O}$			8	pF	$V_{I/O} = 0$ V

Recommended DC Operating Conditions

$T_A = -40$ to $+85^\circ\text{C}$

Parameter	Symbol	Limits			Unit
		Min	Typ	Max	
Supply voltage	V_{CC}	4.5	5.0	5.5	V
Input voltage low	V_{IL}	-0.3		0.8	V
Input voltage high	V_{IH}	2.2		$V_{CC} + 0.3$	V

Truth Table

\overline{CE}_1	\overline{CE}_2	WE	MODE	I/O	I_{CC}
X	H	X	Not selected	Hi-Z	Standby
H	X	X	Not selected	Hi-Z	Standby
L	L	H	Read	D_{OUT}	Active
L	L	L	Write	D_{IN}	Active

AC Test Conditions

Input pulse levels	0.8 to 2.2 V
Input pulse rise and fall time	10 ns
Timing reference levels	1.5 V
Output load	1 TTL +100 pF

DC Characteristics

T_A = -40 to +85°C, V_{CC} = 5 V ± 10%

Parameter	Symbol	Limits			Unit	Test Conditions
		Min	Typ	Max		
Input leakage current	I _{LI}			1	μA	V _{IN} = 0 V to V _{CC}
I/O leakage current	I _{LO}			1	μA	V _{I/O} = 0 V to V _{CC} , CE ₁ or CE ₂ = V _{IH} or WE = V _{IL}
Operating supply current	I _{CCA1}	(1)	(1)		mA	CE ₁ and CE ₂ = V _{IL} , I _{I/O} = 0, min cycle
Operating supply current	I _{CCA2}	5	10		mA	CE ₁ and CE ₂ = V _{IL} , I _{I/O} = 0 DC current
Standby supply current	I _{SB}	0.02	(2)		μA	CE ₁ or CE ₂ ≥ V _{CC} - 0.2 V, other CE input ≤ 0.2 V or ≥ V _{CC} - 0.2 V, V _{IN} = 0 V to V _{CC}

DC Characteristics (cont)

T_A = -40 to +85°C, V_{CC} = 5 V ± 10%

Parameter	Symbol	Limits			Unit	Test Conditions
		Min	Typ	Max		
Output voltage low	V _{OL}			0.4	V	I _{OL} = 2.0 mA
Output voltage high	V _{OH}	2.4			V	I _{OH} = -1.0 mA

Notes:

(1) μPD449C-3/3L, 25 mA typ, 38 mA max
 μPD449C-2/2L, 20 mA typ, 30 mA max
 μPD449C-1/1L, 18 mA typ, 26 mA max
 μPD449C/-L, 12 mA typ, 18 mA max

(2) μPD449C-L/-1L/-2L/-3L
 T_A = 25°C, 0.2 μA max
 T_A = 60°C, 1.0 μA max
 T_A = 85°C, 10 μA max

μPD449C/-1/-2/-3
 T_A = 25°C, 1.0 μA max
 T_A = 60°C, 5.0 μA max
 T_A = 85°C, 10 μA max

AC Characteristics

T_A = -40 to +85°C, V_{CC} = 5 V ± 10%

Parameter	Symbol	μPD449-3		μPD449-2		μPD449-1		μPD449		Unit
		Min	Max	Min	Max	Min	Max	Min	Max	
Read Cycle										
Read cycle time	t _{RC}	150		200		250		450		ns
Address access time	t _A		150		200		250		450	ns
Chip enable (CE ₁) to output valid	t _{CO1}		150		200		250		450	ns
Chip enable (CE ₂) to output valid	t _{CO2}		150		200		250		450	ns
Output hold from address change	t _{OH}	15		15		15		15		ns
Chip enable (CE ₁) to output in Lo-Z	t _{LZ1}	5		5		5		5		ns
Chip enable (CE ₂) to output in Lo-Z	t _{LZ2}	5		5		5		5		ns
Chip enable (CE ₁) to output in Hi-Z	t _{HZ1}		50		60		80		100	ns
Chip enable (CE ₂) to output in Hi-Z	t _{HZ2}		50		60		80		100	ns
Write Cycle										
Write cycle time	t _{WC}	150		200		250		450		ns
Chip enable (CE ₁) to end of write	t _{CW1}	120		150		180		210		ns
Chip enable (CE ₂) to end of write	t _{CW2}	120		150		180		210		ns
Address setup time	t _{AW}	0		0		0		0		ns
Write pulse width	t _{WP}	90		120		150		180		ns
Write recovery time	t _{WR}	0		0		0		0		ns
Data valid to end of write	t _{DW}	50		60		80		100		ns
Data hold time	t _{DH}	0		0		0		0		ns
Write enable to output in Hi-Z	t _{WZ}		50		60		80		100	ns
Output active from end of write	t _{OW}	10		10		10		10		ns

