

1M-BIT CMOS FAST STATIC RAM  
64K-WORD BY 16-BIT**Description**

The  $\mu$ PD431016 is a high speed, low power, 1 048 576 bits (65 536 words by 16 bits) CMOS static RAM.

The  $\mu$ PD431016 are packed in 44-pin plastic SOJ.

**Feature**

- 65 536 words by 16 bits organization
- Fast access time 15, 17, 20 ns (MAX.)
- Output buffers control:  $\overline{OE}$
- Byte data control:  $\overline{LB}$  (I/O1 to I/O8),  $\overline{UB}$  (I/O9 to I/O16)
- Common I/O using three state output
- Fully static operation: no clock or refreshing to operate
- TTL compatible: all inputs and outputs
- Single +5 V power supply

**Ordering Information**

Part number	Package	Access time ns (MAX.)	Operating supply current mA (MAX.)	Standby supply current mA (MAX.)	Quality grade
$\mu$ PD431016LE-15	44-pin plastic SOJ (400 mil)	15	240	10	Standard
$\mu$ PD431016LE-17		17	230		
$\mu$ PD431016LE-20		20	220		

**Remark** Operating supply current is 180 mA (MAX.) when this product is used at 50 ns cycle time.

Please refer to "Quality grade on NEC Semiconductor Devices" (Document number IEI-1209) published by NEC Corporation to know the specification of quality grade on the devices and its recommended applications.

The information in this document is subject to change without notice.

Pin Configuration (Marking Side)

44-Pin Plastic SOJ (400 mil)

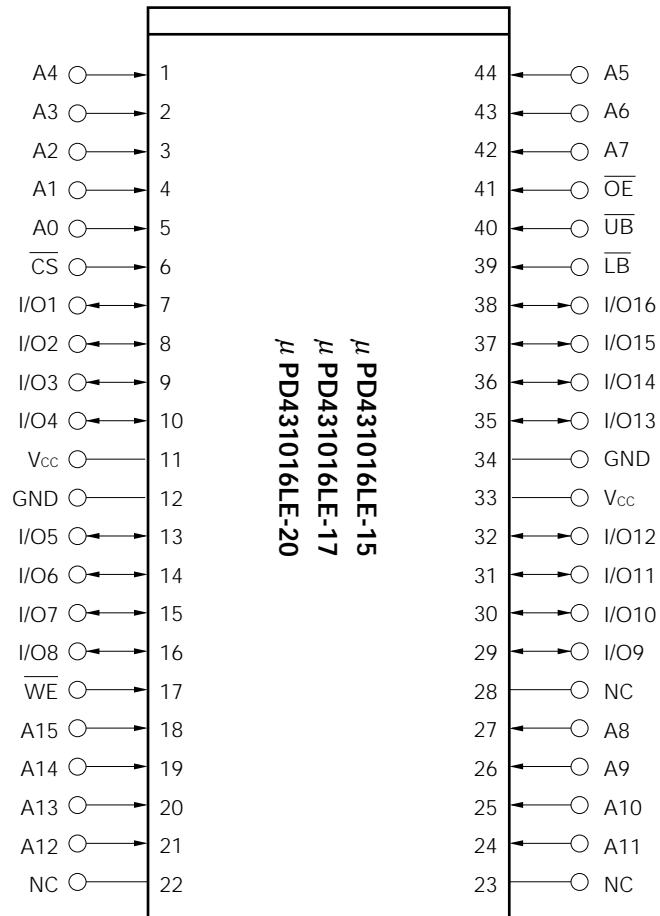

- A0 to A15 : Address Inputs
- I/O1 to I/O16 : Data Inputs/Outputs
- CS : Chip Select
- WE : Write Enable
- OE : Output Enable
- LB, UB : Byte data select
- V<sub>cc</sub> : Power supply
- GND : Ground
- NC : No Connection

Block Diagram

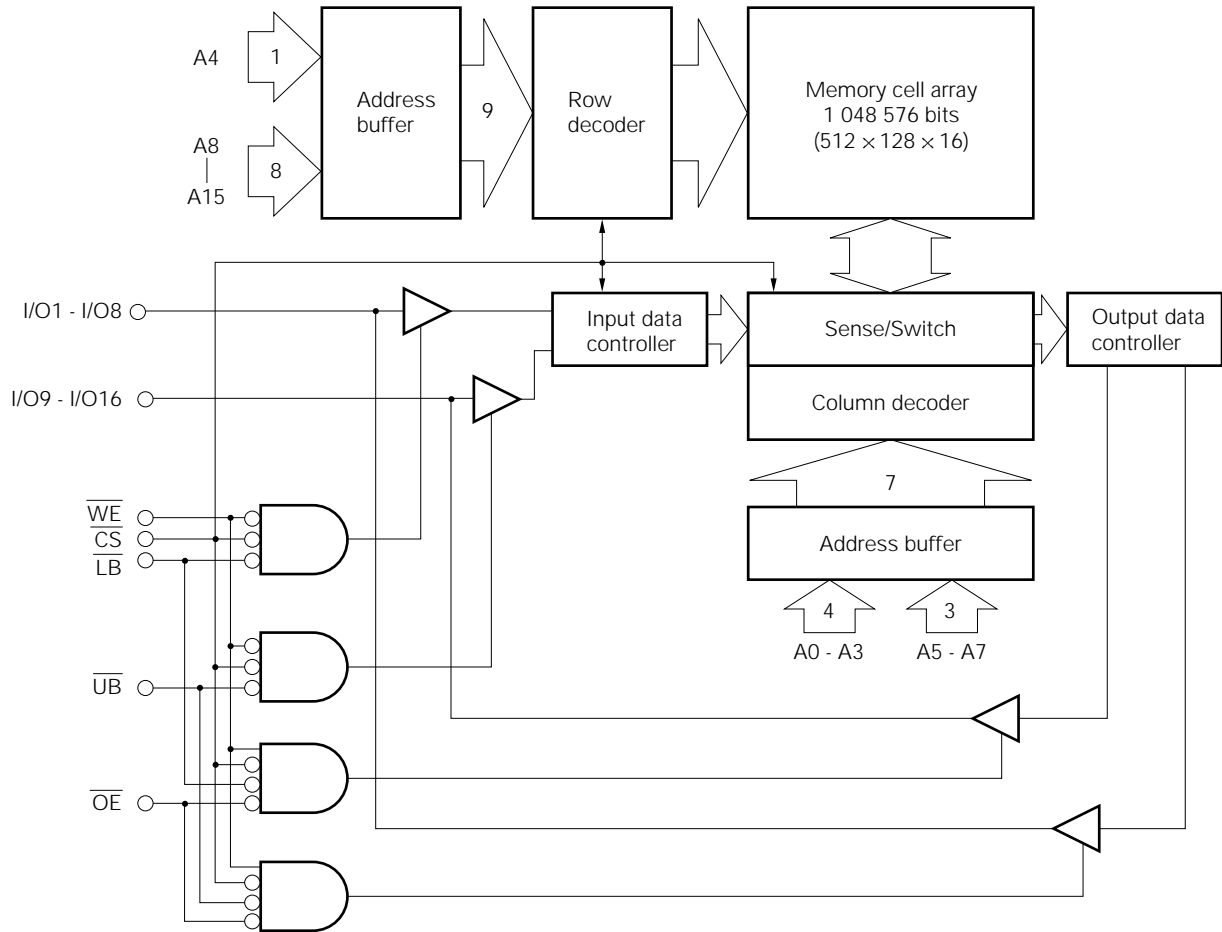

Truth Table

$\overline{CS}$	$\overline{OE}$	$\overline{WE}$	$\overline{LB}$	$\overline{UB}$	Mode	I/O		Supply current
						I/O1 - I/O8	I/O9 - I/O16	
H	X	X	X	X	Not selected	Hi-Z	Hi-Z	$I_{SB}$
L	L	H	L	L	Read	D <sub>OUT</sub>	D <sub>OUT</sub>	$I_{CC}$
			L	H		D <sub>OUT</sub>	Hi-Z	
			H	L		Hi-Z	D <sub>OUT</sub>	
L	X	L	L	L	Write	D <sub>IN</sub>	D <sub>IN</sub>	
			L	H		D <sub>IN</sub>	Hi-Z	
			H	L		Hi-Z	D <sub>IN</sub>	
L	H	H	X	X	Output disable	Hi-Z	Hi-Z	
L	X	X	H	H		Hi-Z	Hi-Z	

Remark X : Don't care

## Electrical Specifications

### Absolute Maximum Ratings

Parameter	Symbol	Rating	Unit
Supply voltage	$V_{CC}$	-0.5 <sup>Note</sup> to +7.0	V
Input/Output voltage	$V_T$	-0.5 <sup>Note</sup> to $V_{CC} + 0.5$	V
Operating temperature	$T_{opt}$	0 to +70	°C
Storage temperature	$T_{stg}$	-55 to +125	°C

**Note** -3.0 V (MIN.) (Pulse width: 10 ns)

### Recommended Operating Conditions

Parameter	Symbol	MIN.	TYP.	MAX.	Unit
Supply voltage	$V_{CC}$	4.5	5.0	5.5	V
High level input voltage	$V_{IH}$	2.2		$V_{CC} + 0.5$	V
Low level input voltage	$V_{IL}$	-0.5 <sup>Note</sup>		+0.8	V
Ambient temperature	$T_a$	0		+70	°C

**Note** -3.0 V (MIN.) (Pulse width: 10 ns)

### DC Characteristics (Recommended operating conditions unless otherwise noted)

Parameter	Symbol	Test conditions	MIN.	TYP.	MAX.	Unit
Input leakage current	$I_{LI}$	$V_{IN} = 0\text{ V to }V_{CC}$	-2		+2	μA
Output leakage current	$I_{LO}$	$V_{I/O} = 0\text{ V to }V_{CC}$ , $\overline{CS} = V_{IH}$ or $\overline{OE} = V_{IH}$ or $\overline{WE} = V_{IL}$ or $\overline{LB} = V_{IH}$ or $\overline{UB} = V_{IH}$	-2		+2	μA
Operating supply current	$I_{CC}$	$\overline{CS} = V_{IL}$ , $I_{I/O} = 0\text{ mA}$	Cycle time: 15 ns		240	mA
			Cycle time: 17 ns		230	
			Cycle time: 20 ns		220	
			Cycle time: 50 ns		180	
Standby supply current	$I_{SB}$	$\overline{CS} = V_{IH}$ , $V_{IN} = V_{IH}$ or $V_{IL}$			30	mA
	$I_{SB1}$	$V_{CC} - 0.2\text{ V} \leq \overline{CS}$ , $V_{IN} \leq 0.2\text{ V}$ or $V_{CC} - 0.2\text{ V} \leq V_{IN}$			10	
High level output voltage	$V_{OH}$	$I_{OH} = -4.0\text{ mA}$	2.4			V
Low level output voltage	$V_{OL}$	$I_{OL} = 8\text{ mA}$			0.4	V

**Remark**  $V_{IN}$ : Input voltage

### Capacitance ( $T_a = +25\text{ °C}$ , $f = 1\text{ MHz}$ )

Parameter	Symbol	Test conditions	MIN.	TYP.	MAX.	Unit
Input capacitance	$C_{IN}$	$V_{IN} = 0\text{ V}$			6	pF
Input/Output capacitance	$C_{I/O}$	$V_{I/O} = 0\text{ V}$			8	pF

**Remark 1.**  $V_{IN}$ : Input voltage

2. These parameters are periodically sampled and not 100 % tested.

AC Characteristics (Recommended operating conditions unless otherwise noted)

AC Test Conditions

Input waveform (Rise/fall time  $\leq 3$  ns)

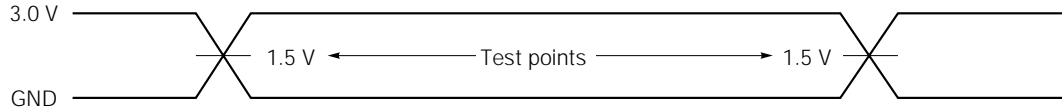

Output waveform

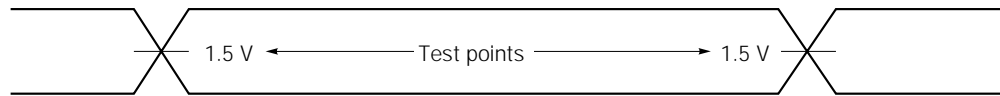

Output load

AC Characteristics directed with the note should be measured with the output load shown in Fig. 1 or Fig. 2.

Fig. 1

(For  $t_{AA}$ ,  $t_{ACS}$ ,  $t_{OE}$ ,  $t_{ADB}$ ,  $t_{OH}$ )

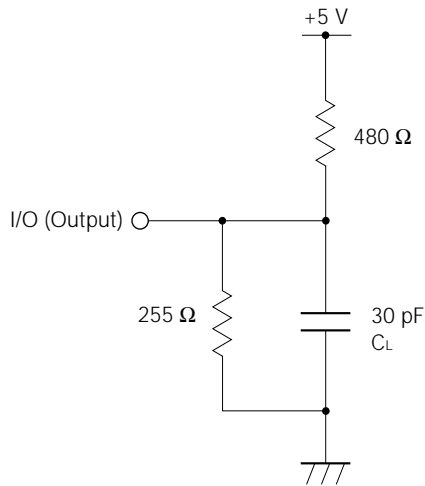
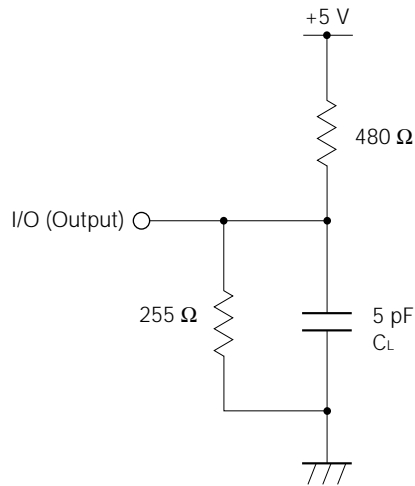

Fig. 2

(For  $t_{CLZ}$ ,  $t_{OLZ}$ ,  $t_{BLZ}$ ,  $t_{CHZ}$ ,  $t_{OHZ}$ ,  $t_{BHZ}$ ,  $t_{WHZ}$ ,  $t_{OW}$ )



**Remark**  $C_L$  includes capacitances of the probe and jig, and stray capacitances.

Read Cycle

Parameter	Symbol	μPD431016LE-15		μPD431016LE-17		μPD431016LE-20		Unit	Condition
		MIN.	MAX.	MIN.	MAX.	MIN.	MAX.		
Read cycle time	$t_{RC}$	15		17		20		ns	
Address access time	$t_{AA}$		15		17		20	ns	<b>Note 1.</b>
$\overline{CS}$ access time	$t_{ACS}$		15		17		20	ns	
$\overline{OE}$ access time	$t_{OE}$		8		9		10	ns	
$\overline{LB}, \overline{UB}$ access time	$t_{ABD}$		8		9		10	ns	
Output hold from address change	$t_{OH}$	5		5		5		ns	
$\overline{CS}$ to output in low-Z	$t_{CLZ}$	5		5		5		ns	<b>Note 2.</b>
$\overline{OE}$ to output in low-Z	$t_{OLZ}$	1		1		1		ns	
$\overline{LB}, \overline{UB}$ to output in low-Z	$t_{BLZ}$	1		1		1		ns	
$\overline{CS}$ to output in high-Z	$t_{CHZ}$		7		7		7	ns	
$\overline{OE}$ to output hold in high-Z	$t_{OHZ}$		7		7		7	ns	
$\overline{LB}, \overline{UB}$ to output hold in high-Z	$t_{BHZ}$		7		7		7	ns	

- Note 1.** See the output load shown in Fig. 1.  
**Note 2.** See the output load shown in Fig. 2.

Read Cycle Timing Chart 1 (Address Access)

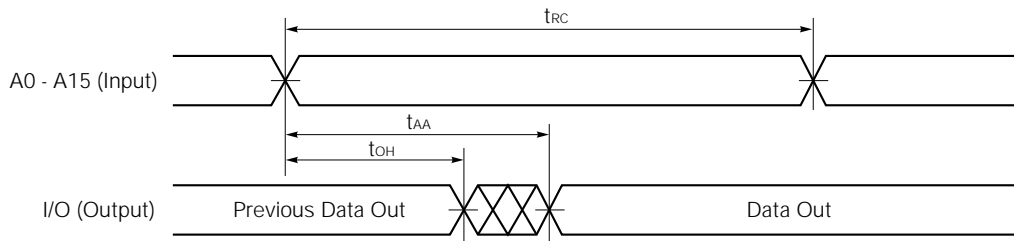

- Remark 1.** In read cycle,  $\overline{WE}$  should be fixed to high level.  
**2.**  $\overline{CS} = \overline{OE} = \overline{LB}$  (or  $\overline{UB}$ ) =  $V_{IL}$

Read Cycle Timing Chart 2 ( $\overline{CS}$  Access)

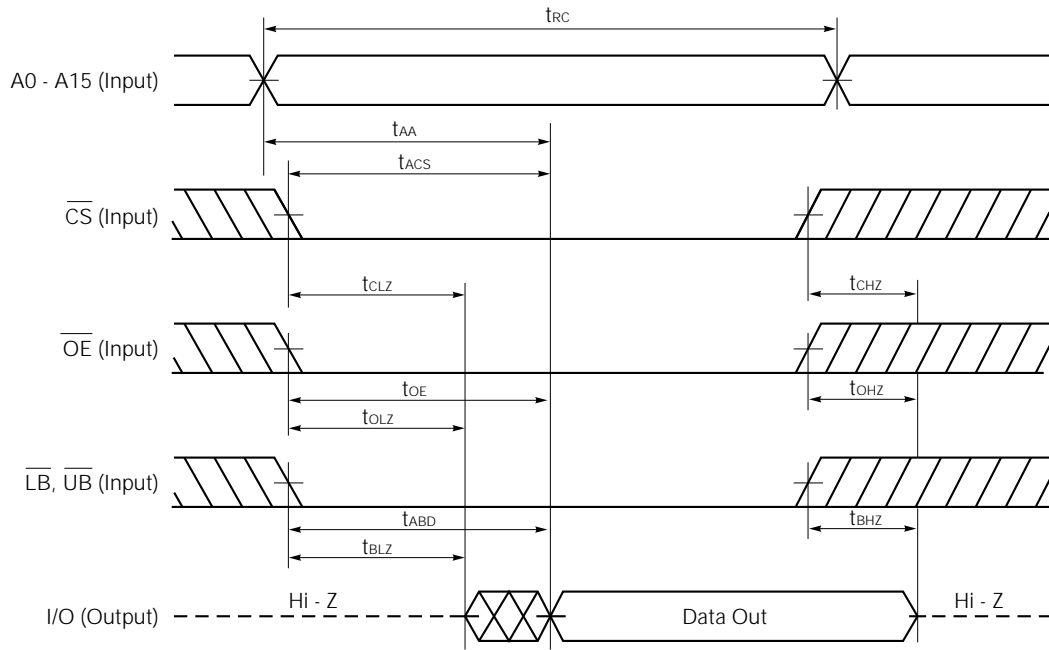

**Caution** Address valid prior to or coincident with  $\overline{CS}$  low level input.

**Remark** In read cycle,  $\overline{WE}$  should be fixed to high level.

Write Cycle

Parameter	Symbol	μPD431016LE-15		μPD431016LE-17		μPD431016LE-20		Unit	Condition
		MIN.	MAX.	MIN.	MAX.	MIN.	MAX.		
Write cycle time	$t_{wc}$	15		17		20		ns	
$\overline{CS}$ to end of write	$t_{cw}$	10		11		12		ns	
Address valid to end of write	$t_{aw}$	9		11		12		ns	
Write pulse width	$t_{wp}$	9		10		10		ns	
$\overline{LB}$ , $\overline{UB}$ to end of write	$t_{bw}$	9		11		12		ns	
Data valid to end of write	$t_{dw}$	8		9		10		ns	
Data hold time	$t_{dh}$	0		0		0		ns	
Address setup time	$t_{as}$	0		0		0		ns	
Write recovery time	$t_{wr}$	0		0		0		ns	
$\overline{WE}$ to output in high-Z	$t_{whz}$		7		7		7	ns	Note
Output active from end of write	$t_{ow}$	3		3		3		ns	

Note See the output load shown in Fig. 2.

Write Cycle Timing Chart 1 (WE Controlled)

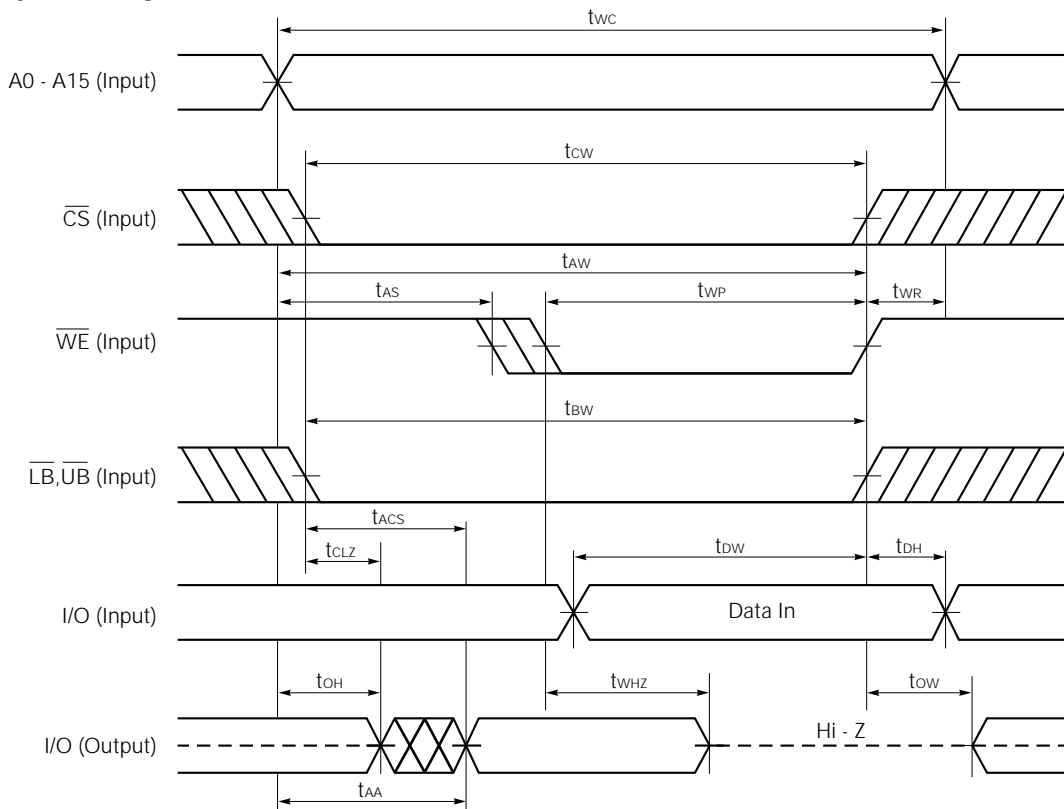

Caution  $\overline{CS}$  or  $\overline{WE}$  should be fixed to high level during address transition.

Remark 1. Write operation is done during the overlap time of low level  $\overline{CS}$ , low level  $\overline{WE}$  and low level  $\overline{LB}$  (or low level  $\overline{UB}$ ).

2. During  $t_{whz}$ , I/O pins are in the output state, therefore the input signals of opposite phase to the output must not be applied.

3. When  $\overline{WE}$  is at low level, the I/O pins are always Hi-Z. When  $\overline{WE}$  is at high level, read operation is executed. Therefore  $\overline{OE}$  should be at high level to make the I/O pins Hi-Z.

Write Cycle Timing Chart 2 ( $\overline{CS}$  Controlled)

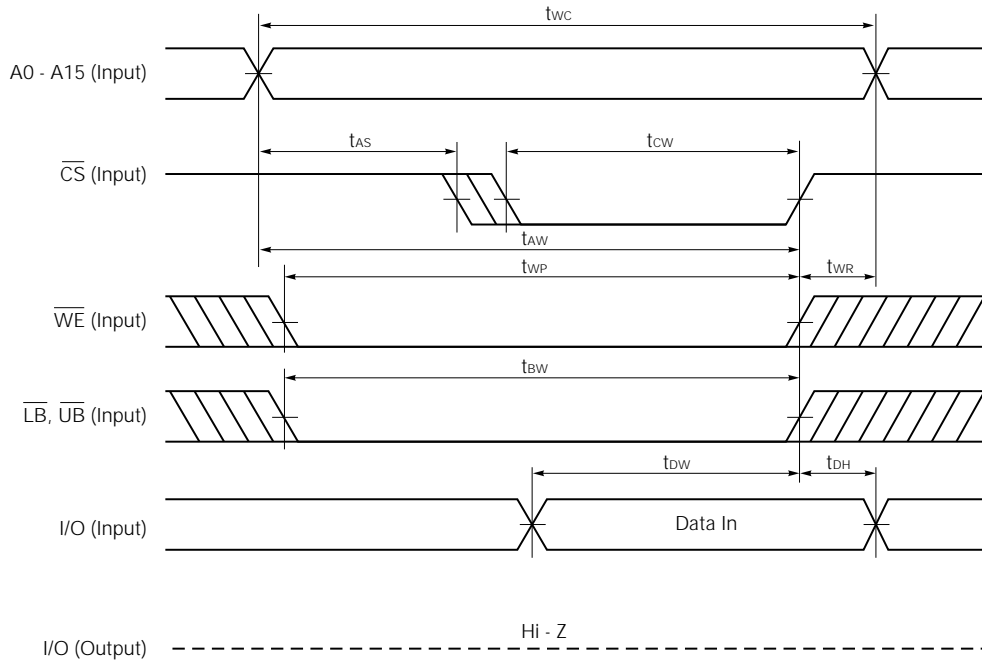

**Caution**  $\overline{CS}$  or  $\overline{WE}$  should be fixed to high level during address transition.

**Remark** Write operation is done during the overlap time of a low level  $\overline{CS}$ , low level  $\overline{WE}$  and low level  $\overline{LB}$  (or low level  $\overline{UB}$ ).

Write Cycle Timing Chart 3 ( $\overline{LB}, \overline{UB}$  Controlled)

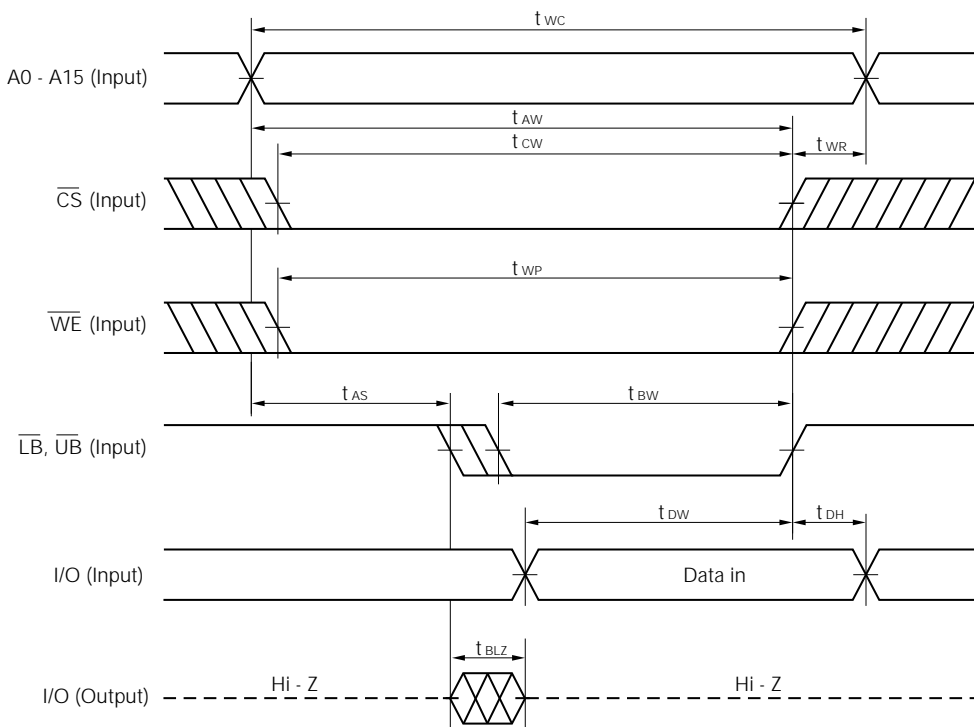

**Caution**  $\overline{CS}$  or  $\overline{WE}$  should be fixed to high level during address transition.

**Remark** Write operation is done during the overlap time of a low level  $\overline{CS}$ , low level  $\overline{WE}$  and low level  $\overline{LB}$  (or low level  $\overline{UB}$ ).

Package Drawing

44 PIN PLASTIC SOJ (400 mil)

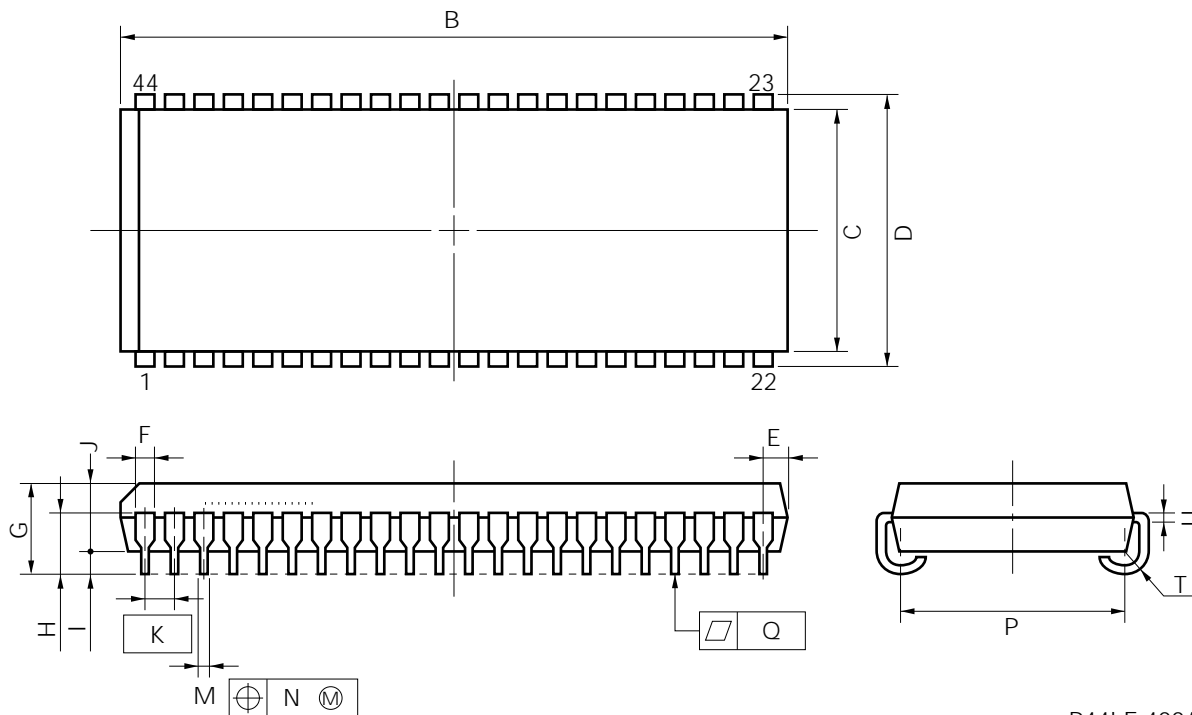

P44LE-400A

**NOTE**

Each lead centerline is located within 0.12 mm (0.005 inch) of its true position (T.P.) at maximum material condition.

ITEM	MILLIMETERS	INCHES
B	28.73 <sup>+0.2</sup> <sub>-0.35</sub>	1.131 <sup>+0.008</sup> <sub>-0.014</sub>
C	10.16	0.400
D	11.18±0.20	0.440±0.008
E	1.03±0.15	0.041 <sup>+0.006</sup> <sub>-0.007</sub>
F	0.74	0.029
G	3.5±0.2	0.138±0.008
H	2.3±0.2	0.091 <sup>+0.008</sup> <sub>-0.009</sub>
I	0.8 MIN.	0.031 MIN.
J	2.6	0.102
K	1.27 (T.P.)	0.050 (T.P.)
M	0.40±0.10	0.016 <sup>+0.004</sup> <sub>-0.005</sub>
N	0.12	0.005
P	9.4±0.20	0.370±0.008
Q	0.10	0.004
T	R 0.85	R 0.033
U	0.20 <sup>+0.10</sup> <sub>-0.05</sub>	0.008 <sup>+0.004</sup> <sub>-0.002</sub>

**RECOMMENDED SOLDERING CONDITIONS**

Please consult with our sales offices for soldering conditions of the  $\mu$ PD431016.

**TYPE OF SURFACE MOUNT DEVICE**

$\mu$ PD431016LE: 44-pin plastic SOJ (400 mil)

[MEMO]

## NOTES FOR CMOS DEVICES

### ① PRECAUTION AGAINST ESD FOR SEMICONDUCTORS

**Note:** Strong electric field, when exposed to a MOS device, can cause destruction of the gate oxide and ultimately degrade the device operation. Steps must be taken to stop generation of static electricity as much as possible, and quickly dissipate it once, when it has occurred. Environmental control must be adequate. When it is dry, humidifier should be used. It is recommended to avoid using insulators that easily build static electricity. Semiconductor devices must be stored and transported in an anti-static container, static shielding bag or conductive material. All test and measurement tools including work bench and floor should be grounded. The operator should be grounded using wrist strap. Semiconductor devices must not be touched with bare hands. Similar precautions need to be taken for PW boards with semiconductor devices on it.

### ② HANDLING OF UNUSED INPUT PINS FOR CMOS

**Note:** No connection for CMOS device inputs can be cause of malfunction. If no connection is provided to the input pins, it is possible that an internal input level may be generated due to noise, etc., hence causing malfunction. CMOS device behave differently than Bipolar or NMOS devices. Input levels of CMOS devices must be fixed high or low by using a pull-up or pull-down circuitry. Each unused pin should be connected to  $V_{DD}$  or GND with a resistor, if it is considered to have a possibility of being an output pin. All handling related to the unused pins must be judged device by device and related specifications governing the devices.

### ③ STATUS BEFORE INITIALIZATION OF MOS DEVICES

**Note:** Power-on does not necessarily define initial status of MOS device. Production process of MOS does not define the initial operation status of the device. Immediately after the power source is turned ON, the devices with reset function have not yet been initialized. Hence, power-on does not guarantee out-pin levels, I/O settings or contents of registers. Device is not initialized until the reset signal is received. Reset operation must be executed immediately after power-on for devices having reset function.

No part of this document may be copied or reproduced in any form or by any means without the prior written consent of NEC Corporation. NEC Corporation assumes no responsibility for any errors which may appear in this document.

NEC Corporation does not assume any liability for infringement of patents, copyrights or other intellectual property rights of third parties by or arising from use of a device described herein or any other liability arising from use of such device. No license, either express, implied or otherwise, is granted under any patents, copyrights or other intellectual property rights of NEC Corporation or others.

The devices listed in this document are not suitable for use in aerospace equipment, submarine cables, nuclear reactor control systems and life support systems. If customers intend to use NEC devices for above applications or they intend to use "Standard" quality grade NEC devices for applications not intended by NEC, please contact our sales people in advance.

Application examples recommended by NEC Corporation

Standard: Computer, Office equipment, Communication equipment, Test and Measurement equipment, Machine tools, Industrial robots, Audio and Visual equipment, Other consumer products, etc.

Special: Automotive and Transportation equipment, Traffic control systems, Antidisaster systems, Anticrime systems, etc.