

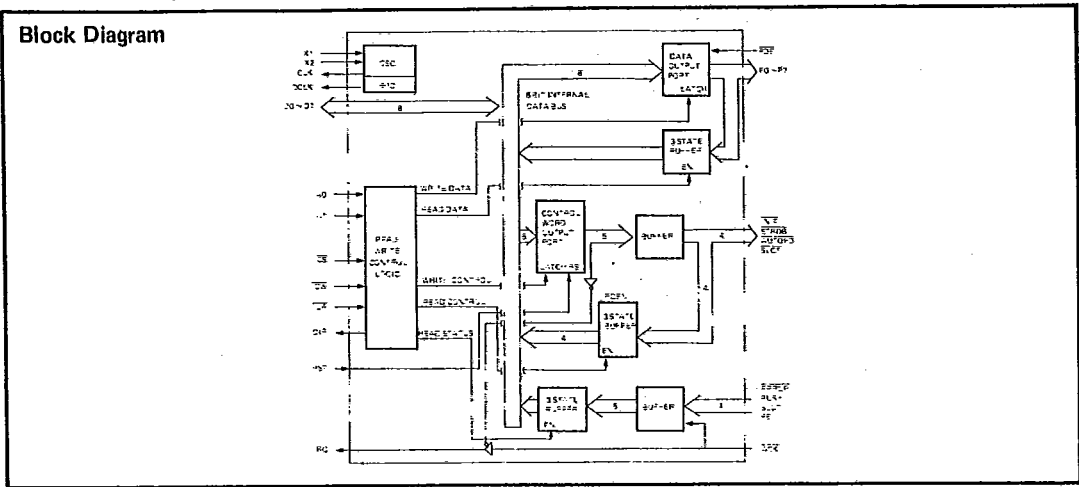

T-52-33-15

UM82C11-C



Absolute Maximum Ratings*

D.C Supply Voltage V_{DD} -0.5V to 7V (with respect to V_{SS})
 Operating Temperature $0^{\circ}\text{C} - 70^{\circ}\text{C}$
 Storage Temperature $-65^{\circ}\text{C} - 150^{\circ}\text{C}$

***Comments**

Stresses above those listed under "Absolute Maximum Ratings" may cause permanent damage to the device. These are stress ratings only. Functional operation of this device at these or any other conditions above those indicated in the operational sections of this specification is not implied and exposure to absolute maximum rating conditions for extended periods may affect device reliability.

D.C. Electrical Characteristics

($T_A = 0^{\circ} - 70^{\circ}\text{C}$, $V_{DD} = +5V \pm 10\%$)

Symbol	Parameter	Min.	Typ.	Max.	Units	Condition
V_{IL}	Input Low Voltage	-	0.4	0.8	V	-
V_{IH}	Input High Voltage	2.0	2.4	-	V	-
V_{OL}	Output Low Voltage	-	0.2	0.4	V	$V_{DD} = 5.5V$ $I_{OL} = \text{Max}$
V_{OH}	Output High Voltage	2.4	-	-	V	$V_{DD} = 4.5V$ $I_{OH} = \text{Max}$
I_{IN}	Input Leakage Current	-	-	± 10	μA	$V_{DD} = 5.5V$ $V_{IN} = V_{DD}$ or GND
I_{OLD}	Output Low Current Printer Data Bus = 0	-	-	24	mA	$V_{OL} = 0.45V$
I_{OHD}	Output High Current Printer Data Bus = 1	-	-	-2.6	mA	$V_{DD} = 5.5V$ $V_{OH} = 2.4V$
I_{OLC}	Output Low Current Printer Control Bus = 0	-	-	7	mA	$V_{OL} = 0.45V$
I_{OHC}	Output High Current Printer Control Bus = 1	-	-	-1.5	mA	$V_{DD} = 5.5V$ $V_{OH} = 2.4V$
I_{FL}	Tristate Leakage Current	-	-	± 10	μA	$V_{DD} = 5.5V$ $V_{FL} = V_{DD}$ or GND
I_{CC}	Quiescent Supply Current	-	-	200	μA	$V_{DD} = 5.5V$ $V_{IN} = 0V$ or V_{DD} $I_O = 0$
I_{OP}	Operating Current*	-	10	-	mA	Oscillation Frequency = 20 MHz, Typical Application

*Operating Current depends on oscillator frequency, output loading and operating temperature.

I/O And Peripherals



T-52-33-15

UM82C11-C

A.C. Characteristics

($T_A = 0^\circ - 70^\circ\text{C}$, $V_{CC} = +5V \pm 10\%$, $C_L = 50\text{ pF}$)

WRITE

Symbol	Parameter	Min.	Max.	Unit
T_{WW}	Write Pulse Width	200	—	ns
T_{AW}	Address to \overline{IOW} Set-up Time	20	—	ns
T_{WA}	Address Hold Time after \overline{IOW}	20	—	ns
T_{DW}	Data to \overline{IOW} Set-up Time	70	—	ns
T_{WD}	Data Hold Time after \overline{IOW}	30	—	ns
T_{WOL}	$\overline{IOW} = 1$ to Data Latched	—	90	ns

READ

Symbol	Parameter	Min.	Max.	Unit
T_{RR}	Read Pulse Width	300	—	ns
T_{DD}	DIR Delay after \overline{IOR}	—	35	ns
T_{AR}	Address to \overline{IOR} Set-up Time	20	—	ns
T_{RA}	Address Hold Time after \overline{IOR}	20	—	ns
T_{PR}	Printer Bus to \overline{IOR} Set-up Time	0	—	ns
T_{RP}	Printer Bus Hold Time after \overline{IOR}	0	—	ns
T_{RDS}	\overline{IOR} to D0 – D7 Output	—	70	ns
T_{RDR}	D0 – D7 Released after \overline{IOR}	0	30	ns

*Note: When the CPU reads the printer's status, output data may change if the printer signals are unstable.

OTHERS

Symbol	Parameter	Min.	Max.	Unit
T_{RSW}	Reset Pulse Width	40	—	ns
T_{RSCH}	Reset to Control Bus = 1 (STROB, AUTOFD, SLCT) Propagation Delay	—	90	ns
T_{RSINI}	Reset to Control Bus $\overline{INIT} = 0$ Propagation Delay	—	60	ns
T_{ID}	\overline{ACK} to IRQ Propagation Delay	—	45	ns
T_{IZ}	IRQ Disable Time	—	50	ns
T_{IE}	IRQ Enable Time	—	50	ns
T_{RSIRZ}	IRQ floating after RST	—	50	ns
T_{DCKD}	CLK to DCLK Printer Data Enable	—	20	ns
T_{ZP}	POE low to Printer Data Enable	—	40	ns
T_{PZ}	POE high to Printer Data Disable	—	40	ns



T-52-33-15

UM82C11-C

Pin Description

Pin	Symbol	Name	I/O	Description
1 2	X1 X2	Crystal In	I	X1, X2 are the pins to which a crystal (whose frequency is between 1.5 MHz and 20 MHz) is attached.
3	CLK	Clock Out	O	A buffered oscillating clock output.
4	DCLK	Divided Clock	O	A buffered clock output whose frequency is one-tenth that of Pin 3.
5	RST	Reset	I	An active high RESET pin. When activated, printer control outputs $\overline{\text{STROB}}$, $\overline{\text{AUTOFD}}$, and $\overline{\text{SLCT}}$ are inactive, $\overline{\text{INIT}}$ is active, and IRQ is disabled remaining high impedance.
6	$\overline{\text{TOW}}$	I/O Write	I	A "Low" on this pin enables the CPU to write data or control words to PAI.
7	$\overline{\text{IOR}}$	I/O Read	I	A "Low" on this pin enables PAI to send data, control words or printer status to the CPU. It allows the CPU to read from PAI.
8	DIR	Direction	O	This output pin is active high only when $\overline{\text{CS}}$ and $\overline{\text{IOR}}$ are activated. It indicates the direction of data transfer between the CPU data bus and PAI. When high, PAI sends data, control words or printer status to the CPU.
9 ~ 16	D0 ~ D7	System Data Bus	I/O	The bidirectional 8-bit data bus pins are connected to the system data bus. Data or control words are transmitted or received upon execution of input or output instructions by the CPU. Status information on the printer is also received through the data bus.
17	IRQ	Interrupt Request	O	This is an interrupt request output pin, which is generated when $\overline{\text{ACK}}$ is high. This pin is enabled by writing D4 = 1 in the control word, and is disabled when D4 = 0. When RST is activated, this pin is disabled.
18	$\overline{\text{CS}}$	Chip Select	I	When $\overline{\text{CS}} = 0$ it enables communications between the CPU and PAI.
19	$\overline{\text{POE}}$	Printer Data Output Enable	I	The printer data output (P0 ~ P7) is enabled when $\overline{\text{POE}} = 0$ and disabled otherwise.
20	V _{SS}	Ground		Power ground pin.
21	$\overline{\text{SLCT}}$	Printer Select	I/O	When activated low, the printer is selected. This pin is programmable in bit $\overline{\text{D3}}$ by writing a control command. PAI outputs the inverted D3 to the $\overline{\text{SLCT}}$ pin.

I/O And
Peripherals

(Cont.)



T-52-33-15

UM82C11-C

Pin Description (Continued)

Pin	Symbol	Name	I/O	Description
22	$\overline{\text{INIT}}$	Initialize	I/O	When activated low, the printer buffer is cleared. This pin is programmable in bit D2 by writing a control command and PAI outputs the D2 signal to this pin. The pulse width of the $\overline{\text{INIT}}$ must be more than 50 μs for initialization of most printers.
23	$\overline{\text{AUTOFD}}$	Auto Feed	I/O	When this pin is low, the printer is fed automatically, one line after printing. This pin is programmable in $\overline{\text{D1}}$ by writing a control command, and PAI outputs the inverted D1 to this pin.
24	$\overline{\text{STROB}}$	Data Strobe	I/O	When activated low, the printer reads in the data on printer data bus P0 ~ P7. It synchronizes the data strobe between PAI and the printer. This pin is programmable in bit D0 by writing a control command, and PAI outputs the inverted $\overline{\text{D0}}$ to this pin.
25	BUSY	Busy State	I	This is an input pin driven by the printer. A "High" indicates that the printer can't receive data at "During Data Entry", "During Part of Paper Feed", "During Printer Error Status", "During Printing" or "In Off-Line State". The CPU can read this signal in D7 by READ STATUS command.
26	$\overline{\text{ACK}}$	Acknowledge	I	This is an input pin driven by the printer. A "Low" indicates that the data has been received and that printer is ready to accept other data. The CPU can read this signal in $\overline{\text{D6}}$ by the READ STATUS command.
27	PE	Paper End	I	This is a pin output from the printer. A "High" indicates that the printer is out of paper. The CPU can read this signal in $\overline{\text{D5}}$ by the "READ STATUS" command.
28	SLCT	Printer Selected Status	I	This is always "High" unless the printer power is down. The CPU can read this signal in $\overline{\text{D4}}$ by the "READ STATUS" command.
29	$\overline{\text{ERROR}}$	Error Status	I	This is input pin driven by the printer. It is "Low" only when the printer is in error status as shown below: (1) Paper end status. (2) Abnormal motor operation. (3) Off-line state. The CPU can read this status in $\overline{\text{D3}}$ by the "READ STATUS" command.
30 ~ 37	P7 ~ P0	Printer Data Bus	I/O	These output pins send out the data to the printer by the CPU "Writing Data" command. They are compatible with the TTL logic level. The CPU can also "Read Back" these data which the CPU last wrote by the "READ DATA" command.
38 39	A0 A1	Address	I	These input addresses, in conjunction with $\overline{\text{TOR}}$, $\overline{\text{TOW}}$, $\overline{\text{CS}}$, control the selection of one of the five commands.
40	V _{DD}	Power Supply		+5V.

Note: The CPU can "Read Back" the control command it last wrote by reading the control word. These are $\overline{\text{STROB}}$, $\overline{\text{AUTOFD}}$, $\overline{\text{INIT}}$, SLCT and IRQEN on the data bus D0 ~ D4.



T-52-33-15
UM82C11-C

Function Description

When reset is activated ($\overline{RST}=1$), $\overline{STROBE}=1$, $\overline{AUTOFD}=1$, $\overline{INIT}=0$, $\overline{SLCT}=1$, and Interrupt Request "IRQ" is disabled. PAI offers five kinds of commands selected by A0, A1, \overline{IOW} , \overline{IOR} and \overline{CS} , as shown below:

Input					Output	Operation
\overline{CS}	A1	A0	\overline{IOR}	\overline{IOW}	DIR	
1	X	X	X	X	0	PAI not activated.
0	0	0	1	0	0	Write data to the printer.
0	0	0	0	1	1	Read data on printer data bus.
0	0	1	0	1	1	Read status from the printer.
0	1	0	1	0	0	Write control word to the printer.
0	1	0	0	1	1	Read control word on printer control bus.
0	Others					(No operation.**)

Notes: **It is illegal to read anything when chip select is active and $A0 = A1 = 1$.

1. WRITE DATA to the PRINTER

Data on D0 ~ D7 are present on P0 ~ P7 bus, parallel and sent to the printer. At the rising edge of \overline{IOW} , data is latched on the P0 ~ P7 bus until the next falling edge of \overline{IOW} . When $\overline{POE} = 1$, P0 ~ P7 bus are disabled to tristate. When $\overline{POE} = 0$ the P0 ~ P7 is enabled.

2. READ DATA on PRINTER DATA BUS

At the falling edge of \overline{IOR} , data on P0 ~ P7 is sent back to CPU through D0 ~ D7, CPU reads back the printer data.

3. READ STATUS from the PRINTER

CPU reads the real-time status of the printer. The states are:

Data	$\overline{D7}$	D6	D5	D4	D3	D2	D1	D0
STATE	BUSY	\overline{ACK}	PE	SLCT	\overline{ERROR}	-	-	-

Note: The BUSY state is inverted on D7.

4. WRITE CONTROL WORD to the PRINTER

CPU writes the control word to the printer. The control signals are:

Data Bus	D7	D6	D5	D4	$\overline{D3}$	D2	$\overline{D1}$	$\overline{D0}$
CONTROL Signal	-	-	-	IRQEN	\overline{SLCT}	\overline{INIT}	\overline{AUTOFD}	\overline{STROB}

The control signals are latched on printer control bus at the rising edge of \overline{IOW} .

Note: "Interrupt Request Enable (IRQEN)" is not present on any output pin, but enables the output pin IRQ when D4 = 1, and disables IRQ to high impedance when D4 = 0. \overline{SLCT} , \overline{AUTOFD} and \overline{STROBE} are inverted on D3, D1 and D0 individually.

5. READ CONTROL WORD on PRINTER CONTROL BUS

At the falling edge of \overline{IOR} , control signal is latched on IRQEN, \overline{SLCT} pin, \overline{INIT} pin, \overline{AUTOFD} pin and \overline{STROB} pin are sent back to CPU on D4, D3, D2, D1 and D0 individually.

- (1) When control word D4 = 0 -----> IRQ pin floating.
- (2) When control word D4 = 1 -----> IRQ = ACK.

I/O And Peripherals



T-52-33-15

UM82C11-C

A.C. Testing Input Waveforms

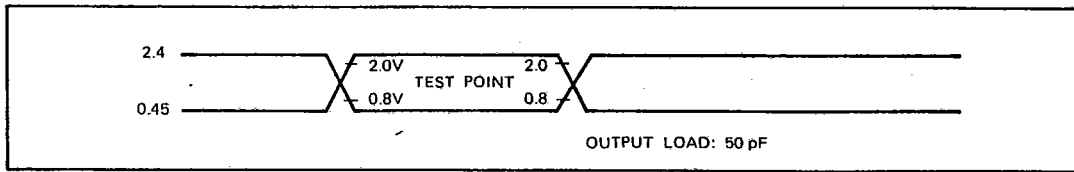

Write Cycle Waveform

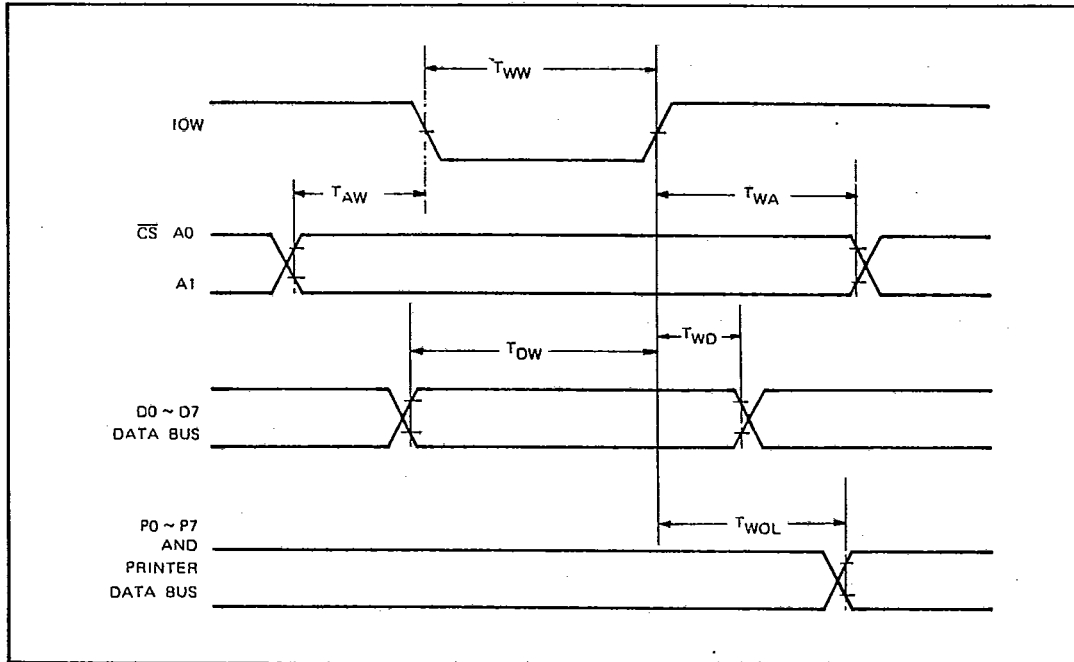

Interrupt Request Waveform

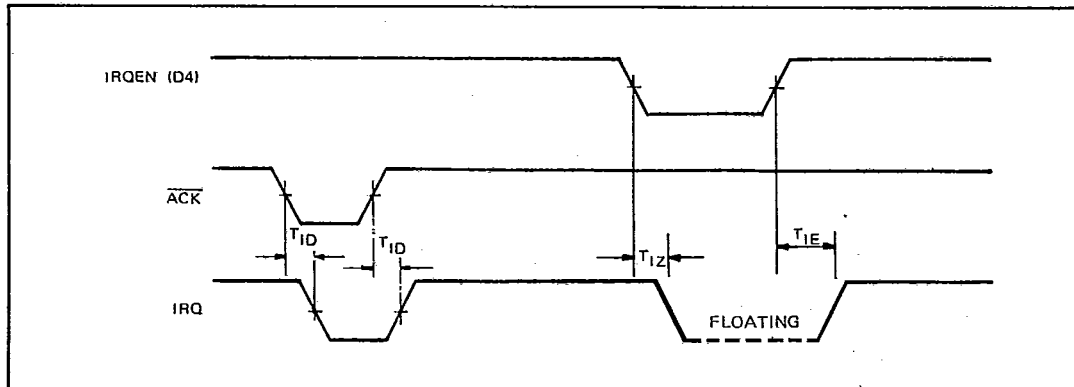

T-52-33-15



UM82C11-C

Read Cycle Waveform

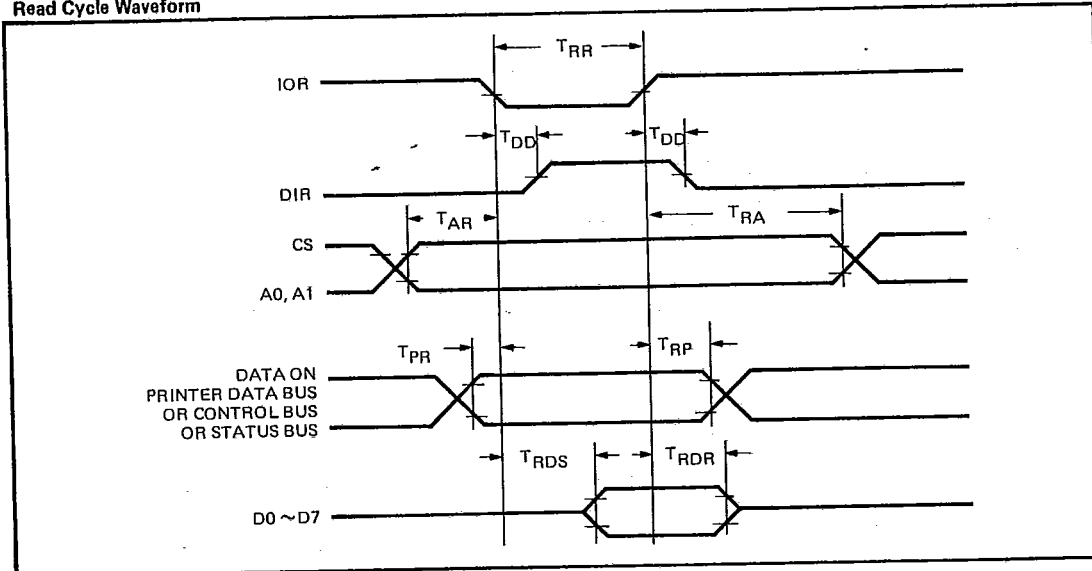

Reset Waveform

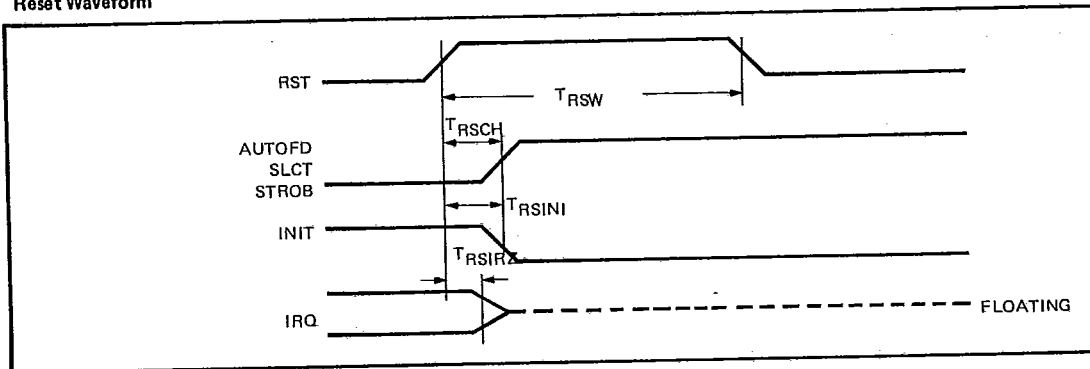

I/O And Peripherals

Clock Waveform

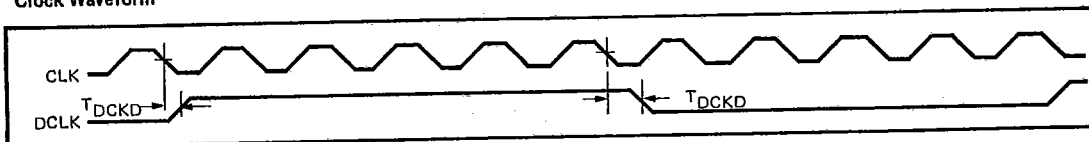

Printer Port Enable/Disable Waveform

