

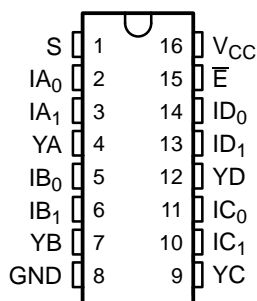
# TS3L110

## QUAD SPDT HIGH-BANDWIDTH 10/100 BASE-T LAN SWITCH DIFFERENTIAL 8-CHANNEL TO 4-CHANNEL MULTIPLEXER/DEMULTIPLEXER

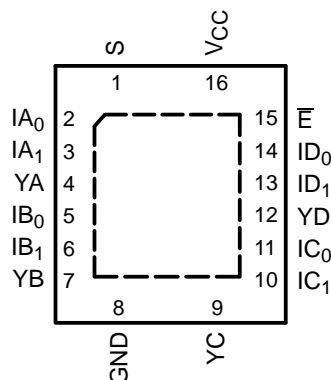
SCDS176 – SEPTEMBER 2004

- Wide Bandwidth (BW = 500 MHz Typ)
- Low Crosstalk ( $X_{TALK} = -30$  dB Typ)
- Bidirectional Data Flow, With Near-Zero Propagation Delay
- Low and Flat ON-State Resistance ( $r_{on} = 4 \Omega$  Typ,  $r_{on(Flat)} = 1 \Omega$ )
- Switching on Data I/O Ports (0 to 5 V)
- $V_{CC}$  Operating Range From 3 V to 3.6 V
- $I_{off}$  Supports Partial-Power-Down Mode Operation
- Data and Control Inputs Have Undershoot Clamp Diodes
- Latch-Up Performance Exceeds 100 mA Per JESD 78, Class II
- ESD Performance Tested Per JESD 22
  - 2000-V Human-Body Model (A114-B, Class II)
  - 1000-V Charged-Device Model (C101)
- Suitable for Both 10 Base-T/100 Base-T Signaling

D, DBQ, DGV, OR PW PACKAGE  
(TOP VIEW)



RGY PACKAGE  
(TOP VIEW)



### description/ordering information

The TI TS3L110 LAN switch is a 4-bit 1-of-2 multiplexer/demultiplexer with a single switch-enable ( $\bar{E}$ ) input. When  $\bar{E}$  is low, the switch is enabled, and the I port is connected to the Y port. When  $\bar{E}$  is high, the switch is disabled, and the high-impedance state exists between the I and Y ports. The select (S) input controls the data path of the multiplexer/demultiplexer.

### ORDERING INFORMATION

T <sub>A</sub>	PACKAGE†		ORDERABLE PART NUMBER	TOP-SIDE MARKING
-40°C to 85°C	QFN – RGY	Tape and reel	TS3L110RGYR	TK110
	SOIC – D	Tube	TS3L110D	TS3L110
		Tape and reel	TS3L110DR	
	SSOP (QSOP) – DBQ	Tape and reel	TS3L110DBQR	TK110
	TSSOP – PW	Tube	TS3L110PW	TK110
		Tape and reel	TS3L110PWR	
TVSOP – DGV	Tape and reel	TS3L110DGVR	TK110	

† Package drawings, standard packing quantities, thermal data, symbolization, and PCB design guidelines are available at [www.ti.com/sc/package](http://www.ti.com/sc/package).



Please be aware that an important notice concerning availability, standard warranty, and use in critical applications of Texas Instruments semiconductor products and disclaimers thereto appears at the end of this data sheet.

PRODUCTION DATA information is current as of publication date. Products conform to specifications per the terms of Texas Instruments standard warranty. Production processing does not necessarily include testing of all parameters.



POST OFFICE BOX 655303 • DALLAS, TEXAS 75265

Copyright © 2004, Texas Instruments Incorporated

**description/ordering information (continued)**

This device can be used to replace mechanical relays in LAN applications. This device has low and flat  $r_{on}$ , wide bandwidth, and low crosstalk, making it suitable for 10 Base-T, 100 Base-T, and various other LAN applications. The device can be used to route signals from a 10/100 Base-T ethernet transceiver to the RJ-45 LAN connectors in laptops or in docking stations. The device is designed for low channel-to-channel skew and low crosstalk.

This device is fully specified for partial-power-down applications using  $I_{off}$ . The  $I_{off}$  feature ensures that damaging current will not backflow through the device when it is powered down. The device has isolation during power off.

To ensure the high-impedance state during power up or power down,  $\bar{E}$  should be tied to  $V_{CC}$  through a pullup resistor; the minimum value of the resistor is determined by the current-sinking capability of the driver.

**FUNCTION TABLE**

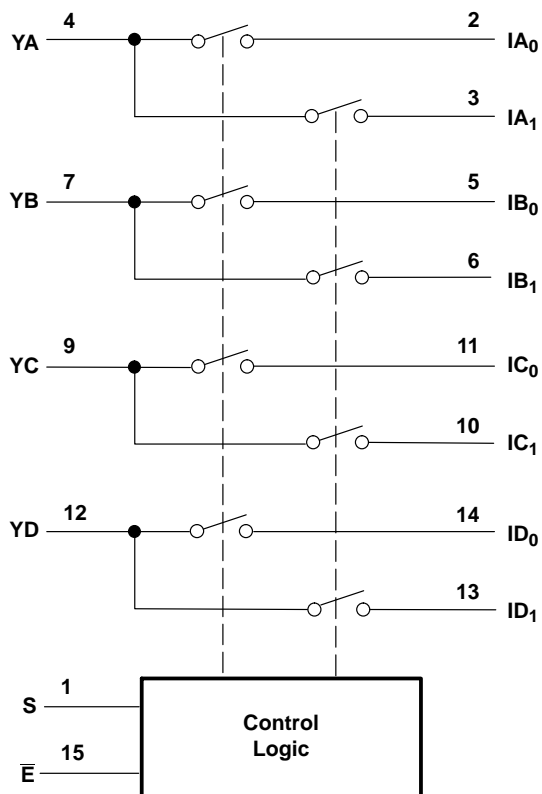
INPUTS		INPUT/OUTPUT YX	FUNCTION
$\bar{E}$	S		
L	L	$IX_0$	$YX = IX_0$
L	H	$IX_1$	$YX = IX_1$
H	X	Z	Disconnect

**PIN DESCRIPTIONS**

PIN NAME	DESCRIPTION
$IAn-IDn$	Data I/Os
S	Select input
$\bar{E}$	Enable input
$YA-YD$	Data I/Os

**TS3L110**  
**QUAD SPDT HIGH-BANDWIDTH 10/100 BASE-T LAN SWITCH**  
**DIFFERENTIAL 8-CHANNEL TO 4-CCHANNEL MULTIPLEXER/DEMULTIPLEXER**  
SCDS176 – SEPTEMBER 2004

logic diagram (positive logic)



# TS3L110

## QUAD SPDT HIGH-BANDWIDTH 10/100 BASE-T LAN SWITCH

### DIFFERENTIAL 8-CHANNEL TO 4-CHANNEL MULTIPLEXER/DEMULTIPLEXER

SCDS176 – SEPTEMBER 2004

#### absolute maximum ratings over operating free-air temperature range (unless otherwise noted)<sup>†</sup>

Supply voltage range, $V_{CC}$	-0.5 V to 4.6 V
Control input voltage range, $V_{IN}$ (see Notes 1 and 2)	-0.5 V to 7 V
Switch I/O voltage range, $V_{I/O}$ (see Notes 1, 2, and 3)	-0.5 V to 7 V
Control input clamp current, $I_{IK}$ ( $V_{IN} < 0$ )	-50 mA
I/O port clamp current, $I_{I/OK}$ ( $V_{I/O} < 0$ )	-50 mA
ON-state switch current, $I_{I/O}$ (see Note 4)	$\pm 128$ mA
Continuous current through $V_{CC}$ or GND terminals	$\pm 100$ mA
Package thermal impedance, $\theta_{JA}$ (see Note 5): D package	73°C/W
(see Note 5): DBQ package	90°C/W
(see Note 5): DGV package	120°C/W
(see Note 5): PW package	108°C/W
(see Note 6): RGY package	39°C/W
Storage temperature range, $T_{stg}$	-65°C to 150°C

<sup>†</sup> Stresses beyond those listed under “absolute maximum ratings” may cause permanent damage to the device. These are stress ratings only, and functional operation of the device at these or any other conditions beyond those indicated under “recommended operating conditions” is not implied. Exposure to absolute-maximum-rated conditions for extended periods may affect device reliability.

- NOTES:
1. All voltages are with respect to ground, unless otherwise specified.
  2. The input and output voltage ratings may be exceeded if the input and output clamp-current ratings are observed.
  3.  $V_I$  and  $V_O$  are used to denote specific conditions for  $V_{I/O}$ .
  4.  $I_I$  and  $I_O$  are used to denote specific conditions for  $I_{I/O}$ .
  5. The package thermal impedance is calculated in accordance with JESD 51-7.
  6. The package thermal impedance is calculated in accordance with JESD 51-5.

#### recommended operating conditions (see Note 7)

		MIN	MAX	UNIT
$V_{CC}$	Supply voltage	3	3.6	V
$V_{IH}$	High-level control input voltage ( $\bar{E}$ , S)	2	5.5	V
$V_{IL}$	Low-level control input voltage ( $\bar{E}$ , S)	0	0.8	V
$V_{I/O}$	Input/output voltage	0	5.5	V
$T_A$	Operating free-air temperature	-40	85	°C

NOTE 7: All unused control inputs of the device must be held at  $V_{CC}$  or GND to ensure proper device operation. Refer to the TI application report, *Implications of Slow or Floating CMOS Inputs*, literature number SCBA004.



**TS3L110**  
**QUAD SPDT HIGH-BANDWIDTH 10/100 BASE-T LAN SWITCH**  
**DIFFERENTIAL 8-CHANNEL TO 4-CHANNEL MULTIPLEXER/DEMULTIPLEXER**

SCDS176 – SEPTEMBER 2004

**electrical characteristics over recommended operating free-air temperature range,  $V_{CC} = 3.3\text{ V} \pm 0.3\text{ V}$  (unless otherwise noted)**

PARAMETER		TEST CONDITIONS		MIN	TYP†	MAX	UNIT	
$V_{IK}$	$\bar{E}, S$	$V_{CC} = 3.6\text{ V},$	$I_{IN} = -18\text{ mA}$			-1.8	V	
$I_{IH}$	$\bar{E}, S$	$V_{CC} = 3.6\text{ V},$	$V_{IN} = 5.5\text{ V}$			$\pm 1$	$\mu\text{A}$	
$I_{IL}$	$\bar{E}, S$	$V_{CC} = 3.6\text{ V},$	$V_{IN} = \text{GND}$			$\pm 1$	$\mu\text{A}$	
$I_{off}$		$V_{CC} = 0,$	$V_O = 0\text{ to }5.5\text{ V},$			1	$\mu\text{A}$	
$I_{CC}$		$V_{CC} = 3.6\text{ V},$	$I_{I/O} = 0,$			0.7	1.5	mA
$C_{in}$	$\bar{E}, S$	$f = 1\text{ MHz},$	$V_{IN} = 0$			2.5	3.5	pF
$C_{io(OFF)}$	I port	$V_I = 0,$	$f = 1\text{ MHz},$ Outputs open,			3.5	5	pF
	Y port	$V_I = 0,$	$f = 1\text{ MHz},$ Outputs open,			5.5	7	
$C_{io(ON)}$	I or Y port	$V_I = 0,$	$f = 1\text{ MHz},$ Outputs open,			10.5	13	pF
$r_{on}$		$V_{CC} = 3\text{ V}$	$1.25\text{ V} \leq V_I \leq V_{CC},$			4	8	$\Omega$
$r_{on(flat)}^\ddagger$		$V_{CC} = 3\text{ V}$	$V_I = 1.25\text{ V}$ and $V_{CC},$			1		$\Omega$
$\Delta r_{on}^\S$		$V_{CC} = 3\text{ V},$	$1.25\text{ V} \leq V_I \leq V_{CC},$			0.9	2	$\Omega$

$V_I, V_O, I_I,$  and  $I_O$  refer to I/O pins.  $V_{IN}$  refers to the control inputs.

† All typical values are at  $V_{CC} = 3.3\text{ V}$  (unless otherwise noted),  $T_A = 25^\circ\text{C}$ .

‡  $r_{on(flat)}$  is the difference of  $r_{on}$  in a given channel at specified voltages.

§  $\Delta r_{on}$  is the difference of  $r_{on}$  in a given device.

**switching characteristics over recommended operating free-air temperature range,  $V_{CC} = 3.3\text{ V} \pm 0.3\text{ V}, R_L = 200\ \Omega, C_L = 10\text{ pF}$  (unless otherwise noted) (see Figures 5 and 6)**

PARAMETER	FROM (INPUT)	TO (OUTPUT)	MIN	TYP†	MAX	UNIT
$t_{pd}^\parallel$	I or Y	Y or I		0.25		ns
$t_{PZH}, t_{PZL}$	$\bar{E}$ or S	I or Y		0.5	7	ns
$t_{PHZ}, t_{PLZ}$	$\bar{E}$ or S	I or Y		0.5	5	ns
$t_{sk(p)}^\#$	I or Y	Y or I		0.1	0.2	ns

† All typical values are at  $V_{CC} = 3.3\text{ V}$  (unless otherwise noted),  $T_A = 25^\circ\text{C}$ .

‡ The propagation delay is the calculated RC time constant of the typical ON-state resistance of the switch and the specified load capacitance when driven by an ideal voltage source (zero output impedance).

# Skew between opposite transitions of the same output  $|t_{PHL} - t_{PLH}|$ . This parameter is not production tested.

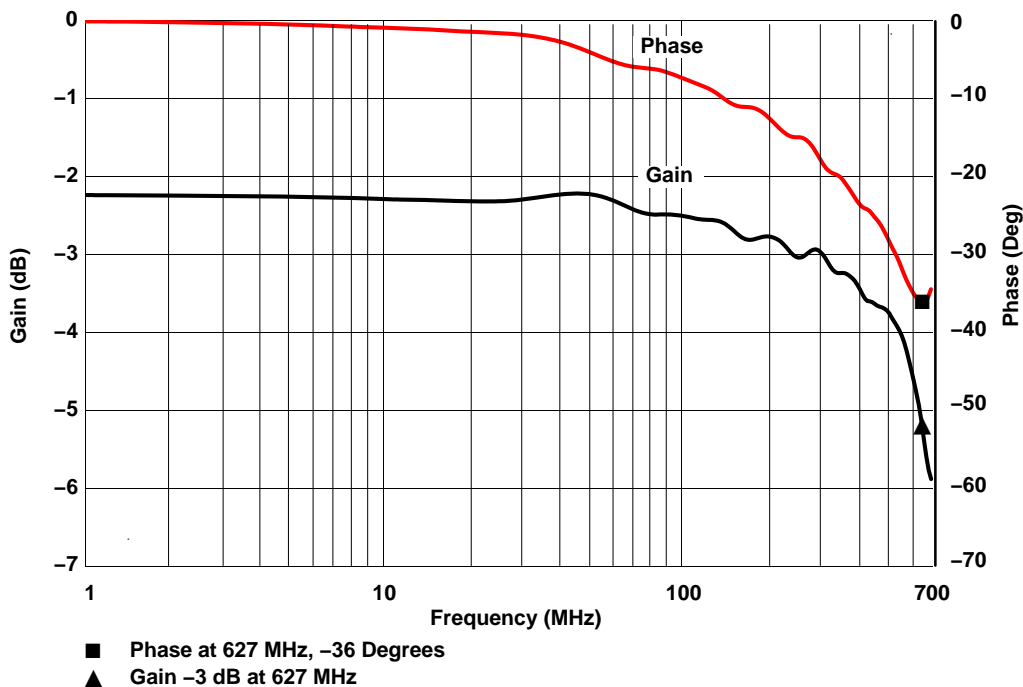
**dynamic characteristics over recommended operating free-air temperature range,  $V_{CC} = 3.3\text{ V} \pm 0.3\text{ V}$  (unless otherwise noted)**

PARAMETER	TEST CONDITIONS	MIN	TYP†	MAX	UNIT
$X_{TALK}$	$R_L = 100\ \Omega,$ $f = 250\text{ MHz},$ see Figure 7		-26		dB
$O_{IRR}$	$R_L = 100\ \Omega,$ $f = 250\text{ MHz},$ see Figure 8		-28		dB
BW	$R_L = 100\ \Omega,$ see Figure 6		500		MHz

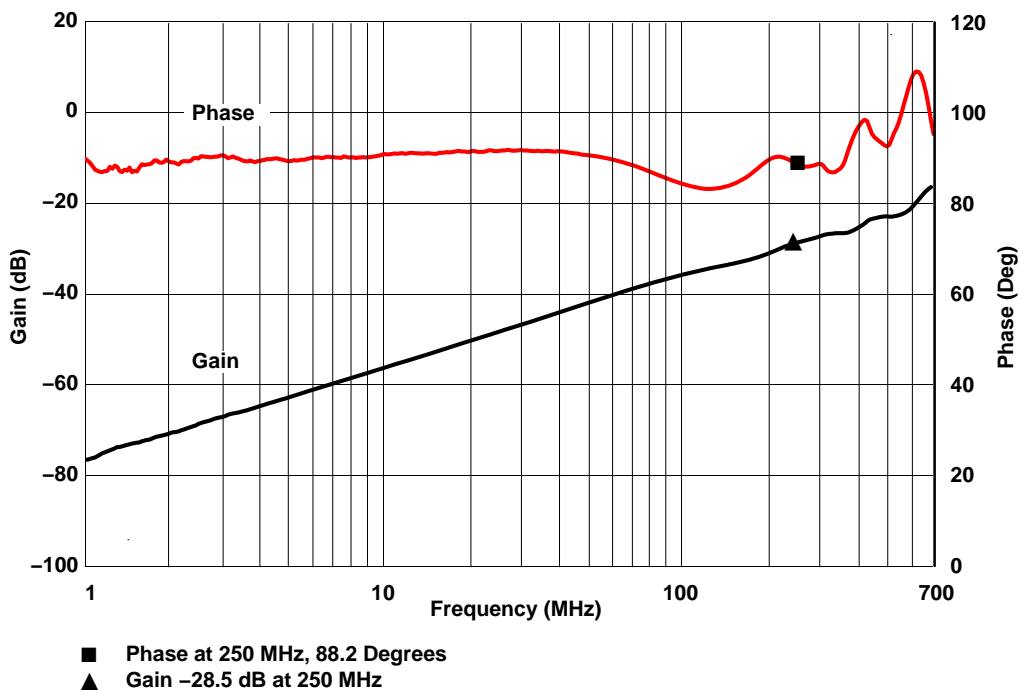
† All typical values are at  $V_{CC} = 3.3\text{ V}$  (unless otherwise noted),  $T_A = 25^\circ\text{C}$ .



**OPERATING CHARACTERISTICS**

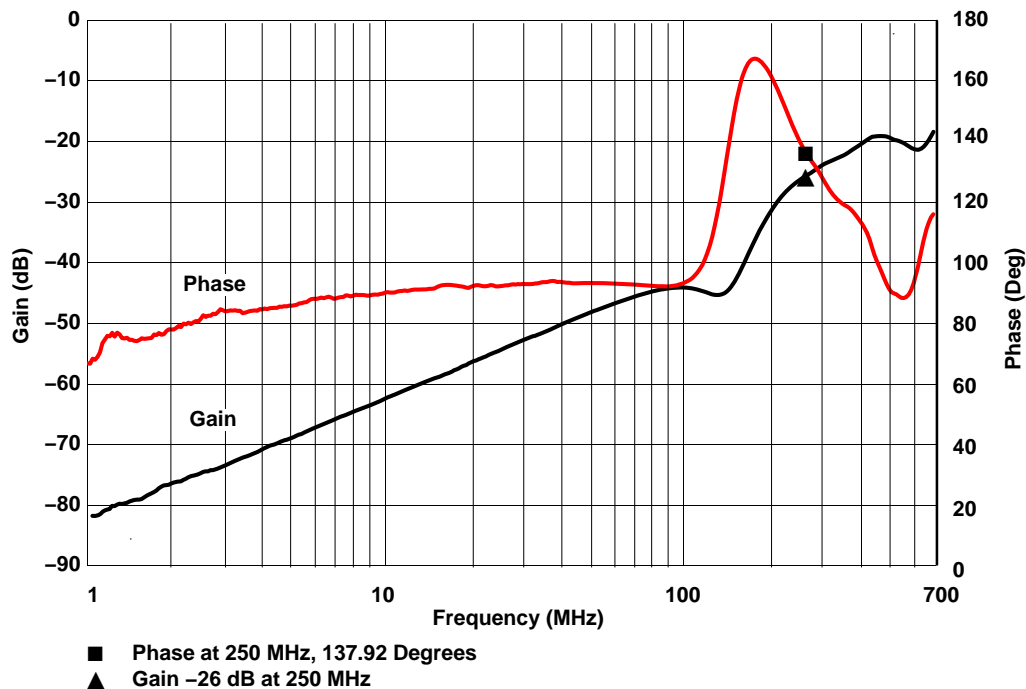


**Figure 1. Gain/Phase vs Frequency**

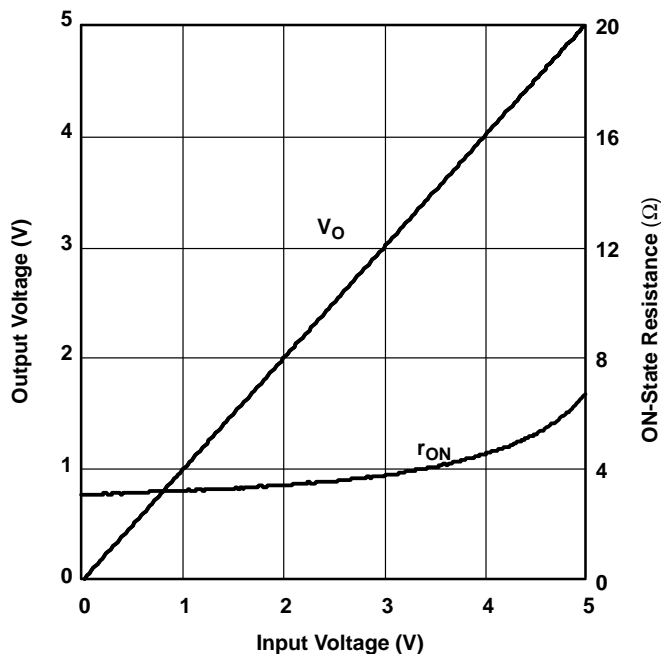


**Figure 2. OFF Isolation vs Frequency**

**OPERATING CHARACTERISTICS**



**Figure 3. Crosstalk vs Frequency**

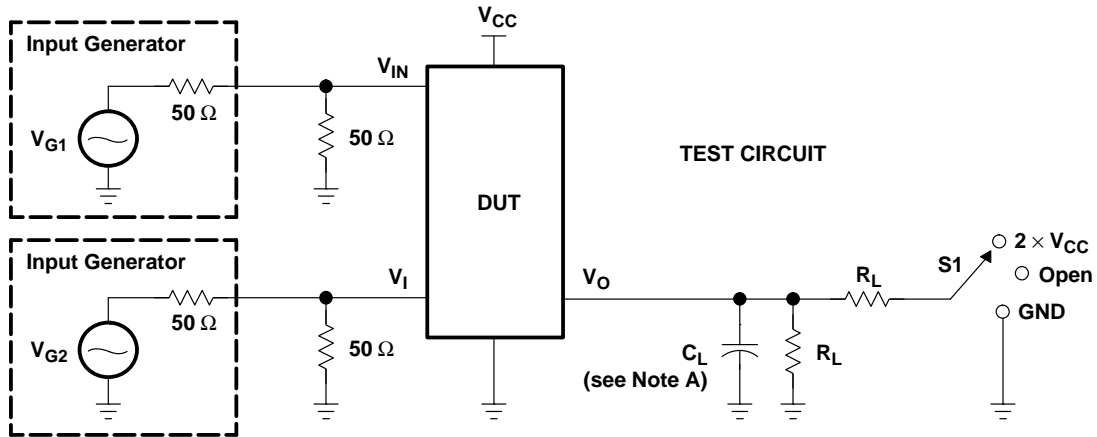


**Figure 4. Output Voltage/ON-State Resistance vs Input Voltage**

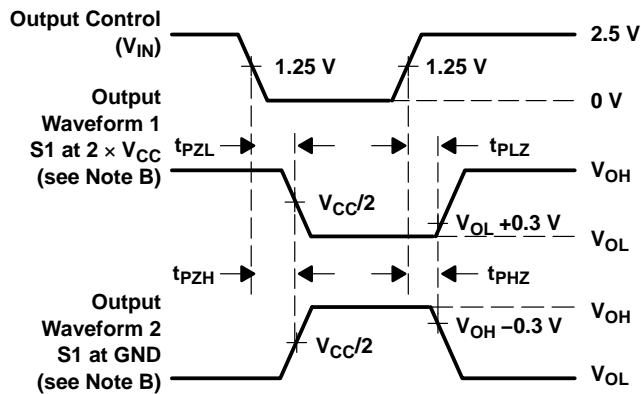
**TS3L110**  
**QUAD SPDT HIGH-BANDWIDTH 10/100 BASE-T LAN SWITCH**  
**DIFFERENTIAL 8-CHANNEL TO 4-CHANNEL MULTIPLEXER/DEMULTIPLEXER**

SCDS176 – SEPTEMBER 2004

**PARAMETER MEASUREMENT INFORMATION**  
**FOR ENABLE AND DISABLE TIMES**



TEST	V <sub>CC</sub>	S1	R <sub>L</sub>	V <sub>I</sub>	C <sub>L</sub>	V <sub>Δ</sub>
t <sub>PLZ</sub> /t <sub>PZL</sub>	3.3 V ± 0.3 V	2 × V <sub>CC</sub>	200 Ω	GND	10 pF	0.3 V
t <sub>PHZ</sub> /t <sub>PZH</sub>	3.3 V ± 0.3 V	GND	200 Ω	V <sub>CC</sub>	10 pF	0.3 V



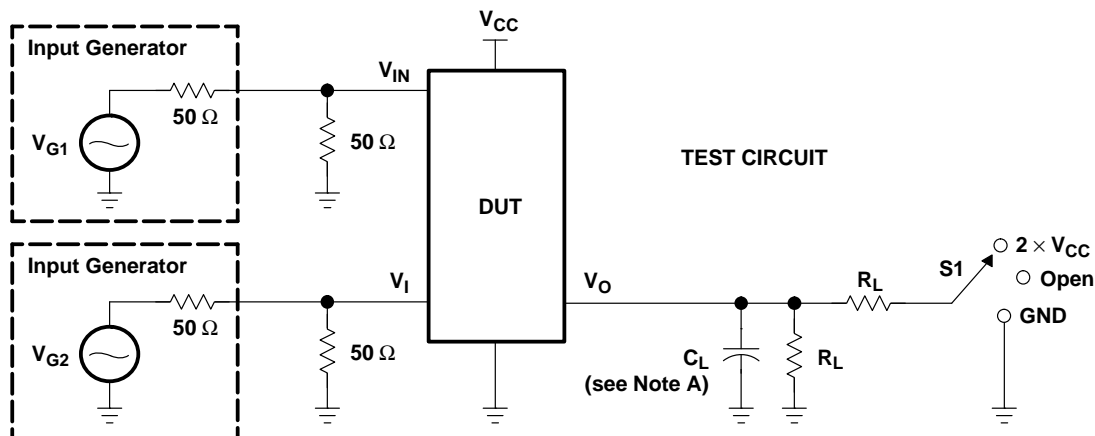
**VOLTAGE WAVEFORMS**  
**ENABLE AND DISABLE TIMES**

- NOTES: A. C<sub>L</sub> includes probe and jig capacitance.  
 B. Waveform 1 is for an output with internal conditions such that the output is low, except when disabled by the output control. Waveform 2 is for an output with internal conditions such that the output is high, except when disabled by the output control.  
 C. All input pulses are supplied by generators having the following characteristics: PRR ≤ 10 MHz, Z<sub>O</sub> = 50 Ω, t<sub>r</sub> ≤ 2.5 ns, t<sub>f</sub> ≤ 2.5 ns.  
 D. The outputs are measured one at a time, with one transition per measurement.  
 E. t<sub>PLZ</sub> and t<sub>PHZ</sub> are the same as t<sub>dis</sub>.  
 F. t<sub>PZL</sub> and t<sub>PZH</sub> are the same as t<sub>en</sub>.

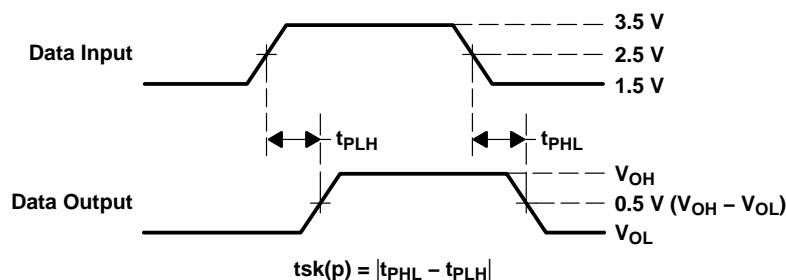
**Figure 5. Test Circuit and Voltage Waveforms**

**TS3L110**  
**QUAD SPDT HIGH-BANDWIDTH 10/100 BASE-T LAN SWITCH**  
**DIFFERENTIAL 8-CHANNEL TO 4-CHANNEL MULTIPLEXER/DEMULTIPLEXER**  
SCDS176 – SEPTEMBER 2004

**PARAMETER MEASUREMENT INFORMATION  
 FOR SKEW**



TEST	V <sub>CC</sub>	S1	R <sub>L</sub>	V <sub>IN</sub> (see Note B)	C <sub>L</sub>
t <sub>sk(p)</sub>	3.3 V ± 0.3 V	GND	200 Ω	V <sub>CC</sub> or GND	10 pF

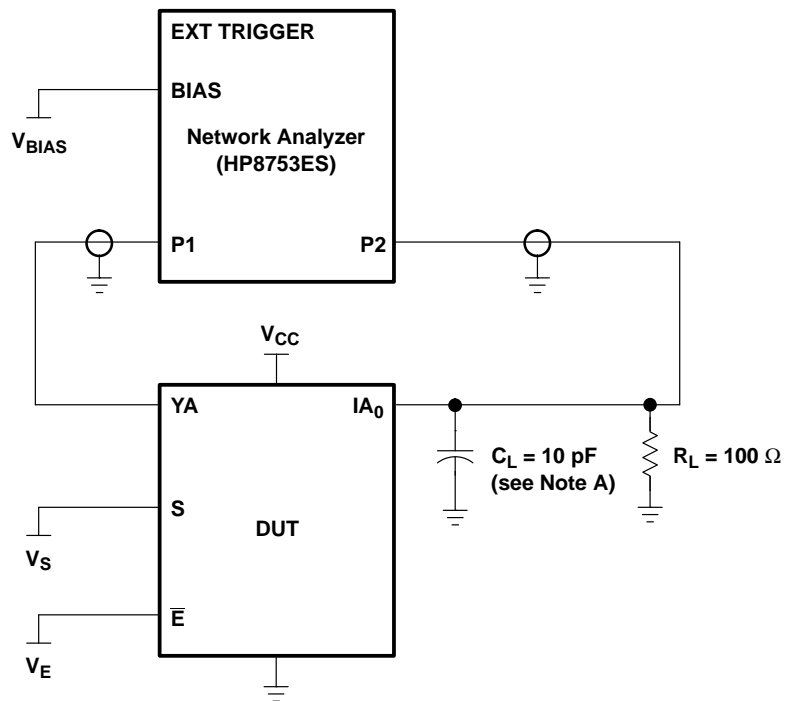


**VOLTAGE WAVEFORMS  
 PULSE SKEW (t<sub>sk(p)</sub>)**

- NOTES: A. C<sub>L</sub> includes probe and jig capacitance.  
 B. Switch is ON during the measurement of t<sub>sk(p)</sub>, i.e., voltage at  $\bar{E} = 0$  and S = V<sub>CC</sub> or GND

**Figure 6. Test Circuit and Voltage Waveforms**

**PARAMETER MEASUREMENT INFORMATION**



NOTE A:  $C_L$  includes probe and jig capacitance.

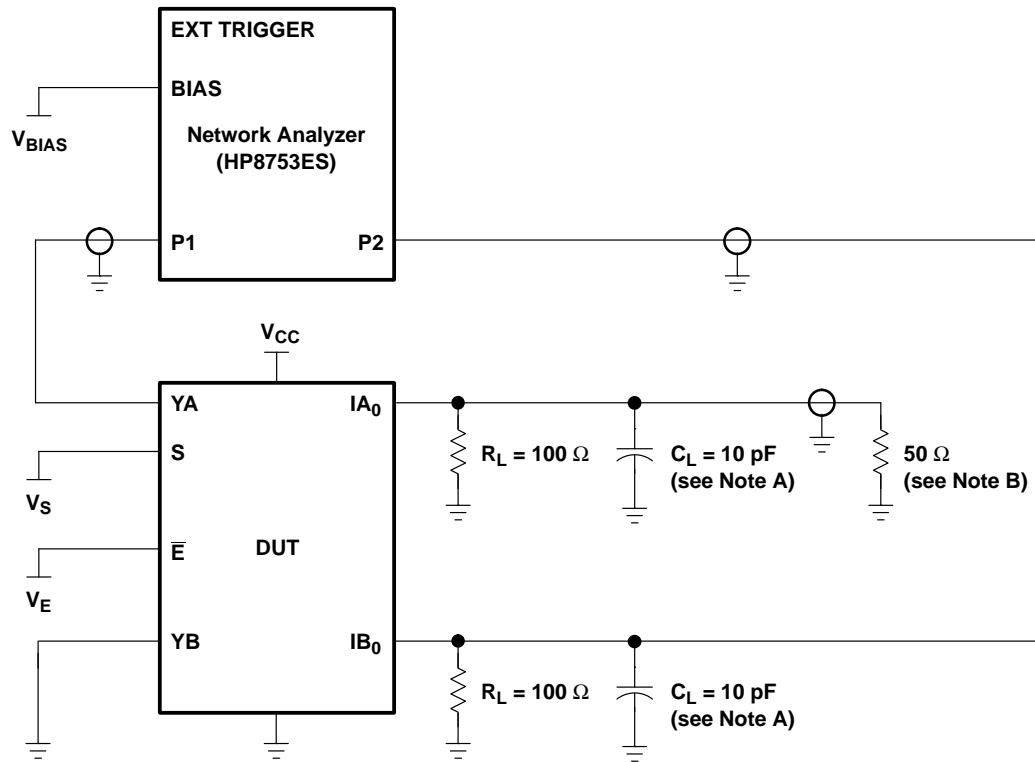
**Figure 7. Test Circuit for Frequency Response (BW)**

Frequency response is measured at the output of the ON channel. For example, when  $V_S = 0$ ,  $V_E = 0$ , and YA is the input, the output is measured at  $IA_0$ . All unused analog I/O ports are left open.

**HP8753ES setup**

- Average = 4
- RBW = 3 kHz
- $V_{BIAS} = 0.35\text{ V}$
- ST = 2 s
- P1 = 0 dBm

**PARAMETER MEASUREMENT INFORMATION**



- NOTES: A.  $C_L$  includes probe and jig capacitance.  
B. A 50- $\Omega$  termination resistor is needed to match the loading of the network analyzer.

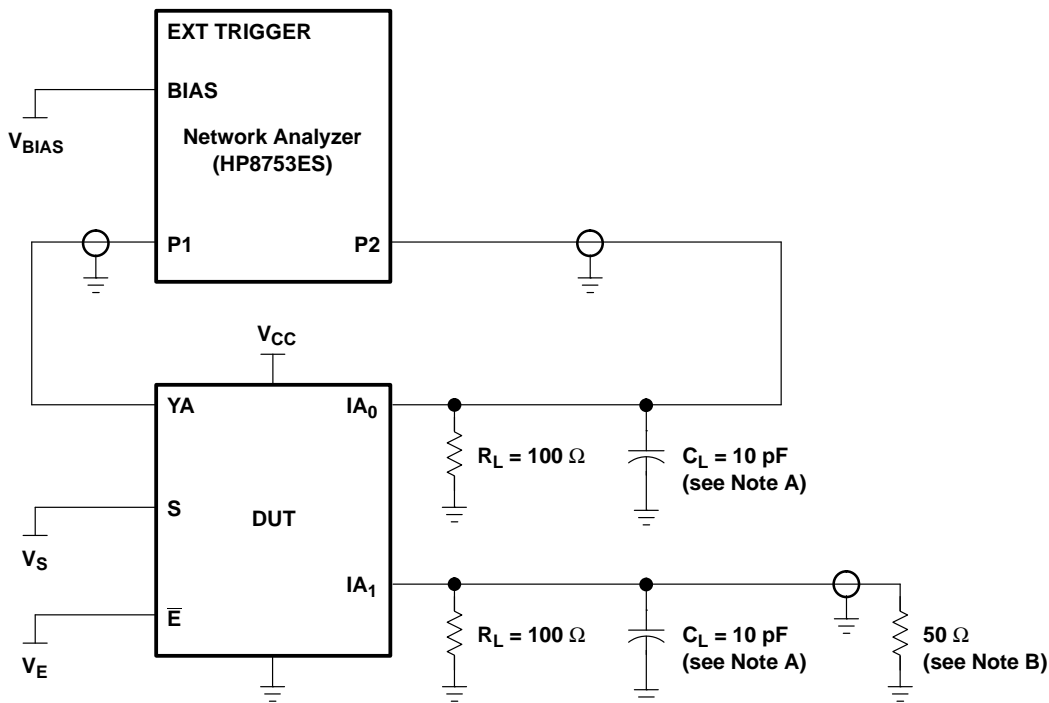
**Figure 8. Test Circuit for Crosstalk ( $X_{TALK}$ )**

Crosstalk is measured at the output of the nonadjacent ON channel. For example, when  $V_S = 0$ ,  $V_E = 0$ , and YA is the input, the output is measured at  $IB_0$ . All unused analog input (Y) ports are connected to GND, and output (I) ports are connected to GND through 50- $\Omega$  pulldown resistors.

**HP8753ES setup**

- Average = 4
- RBW = 3 kHz
- $V_{BIAS} = 0.35$  V
- ST = 2 s
- P1 = 0 dBm

**PARAMETER MEASUREMENT INFORMATION**



- NOTES: A.  $C_L$  includes probe and jig capacitance.  
 B. A 50- $\Omega$  termination resistor is needed to match the loading of the network analyzer.

**Figure 9. Test Circuit for OFF Isolation ( $O_{IRR}$ )**

OFF isolation is measured at the output of the OFF channel. For example, when  $V_S = V_{CC}$ ,  $V_E = 0$ , and YA is the input, the output is measured at IA<sub>0</sub>. All unused analog input (Y) ports are left open, and output (I) ports are connected to GND through 50- $\Omega$  pulldown resistors.

**HP8753ES setup**

- Average = 4
- RBW = 3 kHz
- $V_{BIAS} = 0.35$  V
- ST = 2 s
- P1 = 0 dBm

**PACKAGING INFORMATION**

Orderable Device	Status (1)	Package Type	Package Drawing	Pins	Package Qty	Eco Plan (2)	Lead/Ball Finish (6)	MSL Peak Temp (3)	Op Temp (°C)	Device Marking (4/5)	Samples
TS3L110D	ACTIVE	SOIC	D	16	40	Green (RoHS & no Sb/Br)	CU NIPDAU	Level-1-260C-UNLIM	-40 to 85	TS3L110	<a href="#">Samples</a>
TS3L110DBQR	ACTIVE	SSOP	DBQ	16	2500	Green (RoHS & no Sb/Br)	CU NIPDAU	Level-2-260C-1 YEAR	-40 to 85	TK110	<a href="#">Samples</a>
TS3L110DBQRG4	ACTIVE	SSOP	DBQ	16	2500	Green (RoHS & no Sb/Br)	CU NIPDAU	Level-2-260C-1 YEAR	-40 to 85	TK110	<a href="#">Samples</a>
TS3L110DE4	ACTIVE	SOIC	D	16	40	Green (RoHS & no Sb/Br)	CU NIPDAU	Level-1-260C-UNLIM	-40 to 85	TS3L110	<a href="#">Samples</a>
TS3L110DG4	ACTIVE	SOIC	D	16	40	Green (RoHS & no Sb/Br)	CU NIPDAU	Level-1-260C-UNLIM	-40 to 85	TS3L110	<a href="#">Samples</a>
TS3L110DGVR	ACTIVE	TVSOP	DGV	16	2000	Green (RoHS & no Sb/Br)	CU NIPDAU	Level-1-260C-UNLIM	-40 to 85	TK110	<a href="#">Samples</a>
TS3L110DR	ACTIVE	SOIC	D	16	2500	Green (RoHS & no Sb/Br)	CU NIPDAU	Level-1-260C-UNLIM	-40 to 85	TS3L110	<a href="#">Samples</a>
TS3L110PW	ACTIVE	TSSOP	PW	16	90	Green (RoHS & no Sb/Br)	CU NIPDAU	Level-1-260C-UNLIM	-40 to 85	TK110	<a href="#">Samples</a>
TS3L110PWG4	ACTIVE	TSSOP	PW	16	90	Green (RoHS & no Sb/Br)	CU NIPDAU	Level-1-260C-UNLIM	-40 to 85	TK110	<a href="#">Samples</a>
TS3L110PWR	ACTIVE	TSSOP	PW	16	2000	Green (RoHS & no Sb/Br)	CU NIPDAU	Level-1-260C-UNLIM	-40 to 85	TK110	<a href="#">Samples</a>
TS3L110PWRE4	ACTIVE	TSSOP	PW	16	2000	Green (RoHS & no Sb/Br)	CU NIPDAU	Level-1-260C-UNLIM	-40 to 85	TK110	<a href="#">Samples</a>
TS3L110PWRG4	ACTIVE	TSSOP	PW	16	2000	Green (RoHS & no Sb/Br)	CU NIPDAU	Level-1-260C-UNLIM	-40 to 85	TK110	<a href="#">Samples</a>
TS3L110RGYR	ACTIVE	VQFN	RGY	16	3000	Green (RoHS & no Sb/Br)	CU NIPDAU	Level-2-260C-1 YEAR	-40 to 85	TK110	<a href="#">Samples</a>
TS3L110RGYRG4	ACTIVE	VQFN	RGY	16	3000	Green (RoHS & no Sb/Br)	CU NIPDAU	Level-2-260C-1 YEAR	-40 to 85	TK110	<a href="#">Samples</a>

(1) The marketing status values are defined as follows:

**ACTIVE:** Product device recommended for new designs.

**LIFEBUY:** TI has announced that the device will be discontinued, and a lifetime-buy period is in effect.

**NRND:** Not recommended for new designs. Device is in production to support existing customers, but TI does not recommend using this part in a new design.

**PREVIEW:** Device has been announced but is not in production. Samples may or may not be available.

**OBSOLETE:** TI has discontinued the production of the device.

(2) Eco Plan - The planned eco-friendly classification: Pb-Free (RoHS), Pb-Free (RoHS Exempt), or Green (RoHS & no Sb/Br) - please check <http://www.ti.com/productcontent> for the latest availability information and additional product content details.

**TBD:** The Pb-Free/Green conversion plan has not been defined.

**Pb-Free (RoHS):** TI's terms "Lead-Free" or "Pb-Free" mean semiconductor products that are compatible with the current RoHS requirements for all 6 substances, including the requirement that lead not exceed 0.1% by weight in homogeneous materials. Where designed to be soldered at high temperatures, TI Pb-Free products are suitable for use in specified lead-free processes.

**Pb-Free (RoHS Exempt):** This component has a RoHS exemption for either 1) lead-based flip-chip solder bumps used between the die and package, or 2) lead-based die adhesive used between the die and leadframe. The component is otherwise considered Pb-Free (RoHS compatible) as defined above.

**Green (RoHS & no Sb/Br):** TI defines "Green" to mean Pb-Free (RoHS compatible), and free of Bromine (Br) and Antimony (Sb) based flame retardants (Br or Sb do not exceed 0.1% by weight in homogeneous material)

(3) MSL, Peak Temp. - The Moisture Sensitivity Level rating according to the JEDEC industry standard classifications, and peak solder temperature.

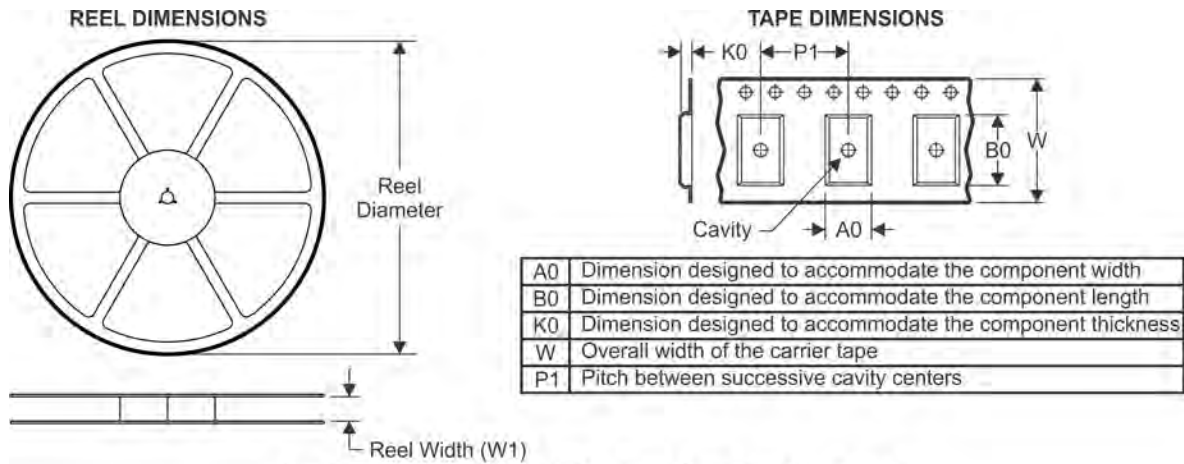
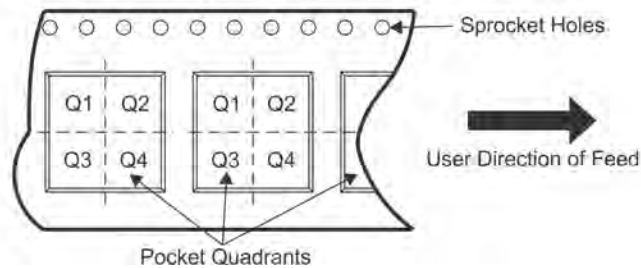
(4) There may be additional marking, which relates to the logo, the lot trace code information, or the environmental category on the device.

(5) Multiple Device Markings will be inside parentheses. Only one Device Marking contained in parentheses and separated by a "~" will appear on a device. If a line is indented then it is a continuation of the previous line and the two combined represent the entire Device Marking for that device.

(6) Lead/Ball Finish - Orderable Devices may have multiple material finish options. Finish options are separated by a vertical ruled line. Lead/Ball Finish values may wrap to two lines if the finish value exceeds the maximum column width.

**Important Information and Disclaimer:** The information provided on this page represents TI's knowledge and belief as of the date that it is provided. TI bases its knowledge and belief on information provided by third parties, and makes no representation or warranty as to the accuracy of such information. Efforts are underway to better integrate information from third parties. TI has taken and continues to take reasonable steps to provide representative and accurate information but may not have conducted destructive testing or chemical analysis on incoming materials and chemicals. TI and TI suppliers consider certain information to be proprietary, and thus CAS numbers and other limited information may not be available for release.

In no event shall TI's liability arising out of such information exceed the total purchase price of the TI part(s) at issue in this document sold by TI to Customer on an annual basis.

**TAPE AND REEL INFORMATION**

**QUADRANT ASSIGNMENTS FOR PIN 1 ORIENTATION IN TAPE**


\*All dimensions are nominal

Device	Package Type	Package Drawing	Pins	SPQ	Reel Diameter (mm)	Reel Width W1 (mm)	A0 (mm)	B0 (mm)	K0 (mm)	P1 (mm)	W (mm)	Pin1 Quadrant
TS3L110DBQR	SSOP	DBQ	16	2500	330.0	12.5	6.4	5.2	2.1	8.0	12.0	Q1
TS3L110DGVR	TVSOP	DGV	16	2000	330.0	12.4	6.8	4.0	1.6	8.0	12.0	Q1
TS3L110DR	SOIC	D	16	2500	330.0	16.4	6.5	10.3	2.1	8.0	16.0	Q1
TS3L110PWR	TSSOP	PW	16	2000	330.0	12.4	6.9	5.6	1.6	8.0	12.0	Q1
TS3L110RGYR	VQFN	RGY	16	3000	330.0	12.4	3.8	4.3	1.5	8.0	12.0	Q1

**TAPE AND REEL BOX DIMENSIONS**

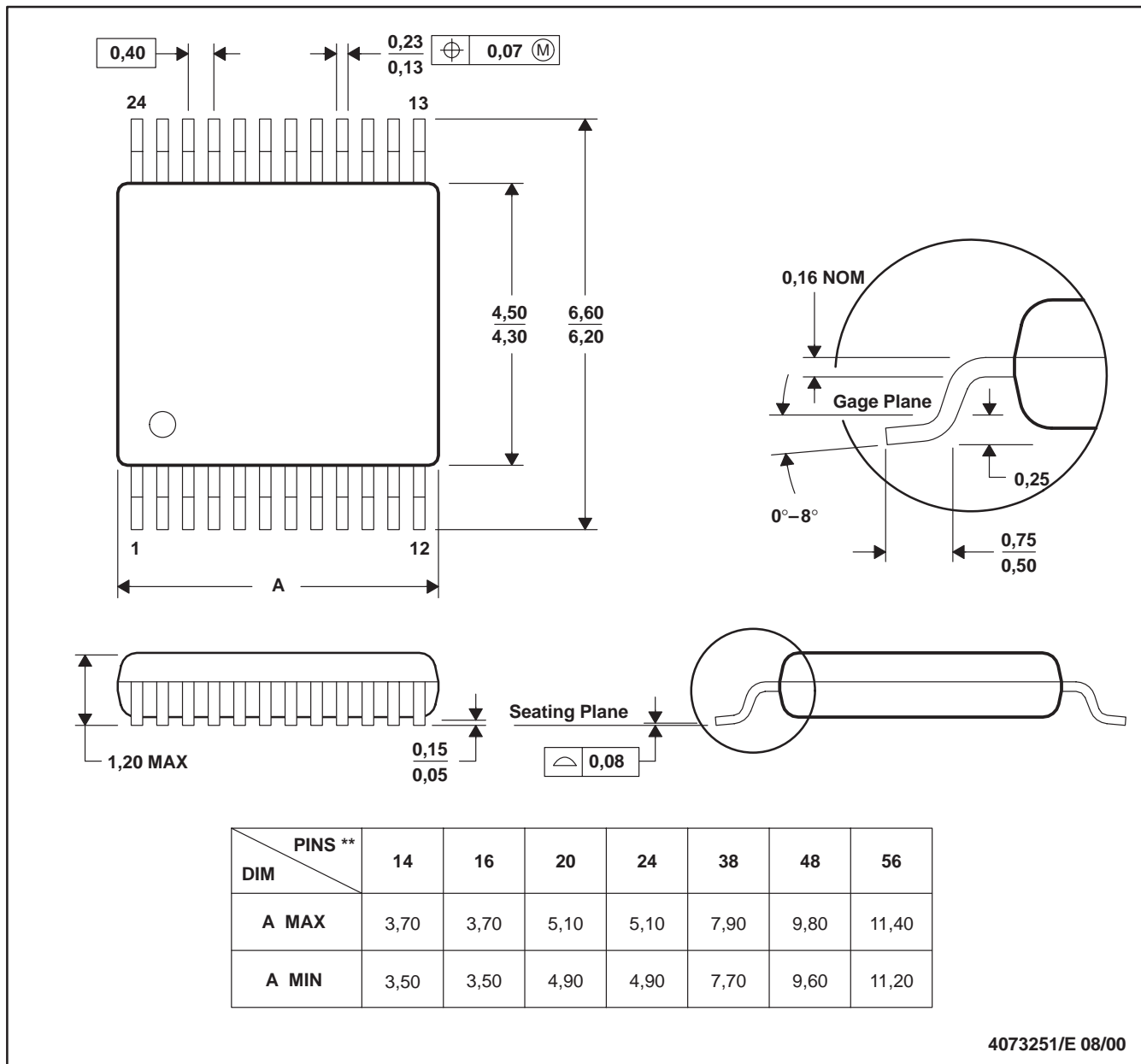

\*All dimensions are nominal

Device	Package Type	Package Drawing	Pins	SPQ	Length (mm)	Width (mm)	Height (mm)
TS3L110DBQR	SSOP	DBQ	16	2500	340.5	338.1	20.6
TS3L110DGVR	TVSOP	DGV	16	2000	367.0	367.0	35.0
TS3L110DR	SOIC	D	16	2500	333.2	345.9	28.6
TS3L110PWR	TSSOP	PW	16	2000	367.0	367.0	35.0
TS3L110RGYR	VQFN	RGY	16	3000	367.0	367.0	35.0

DGV (R-PDSO-G\*\*)

PLASTIC SMALL-OUTLINE

24 PINS SHOWN

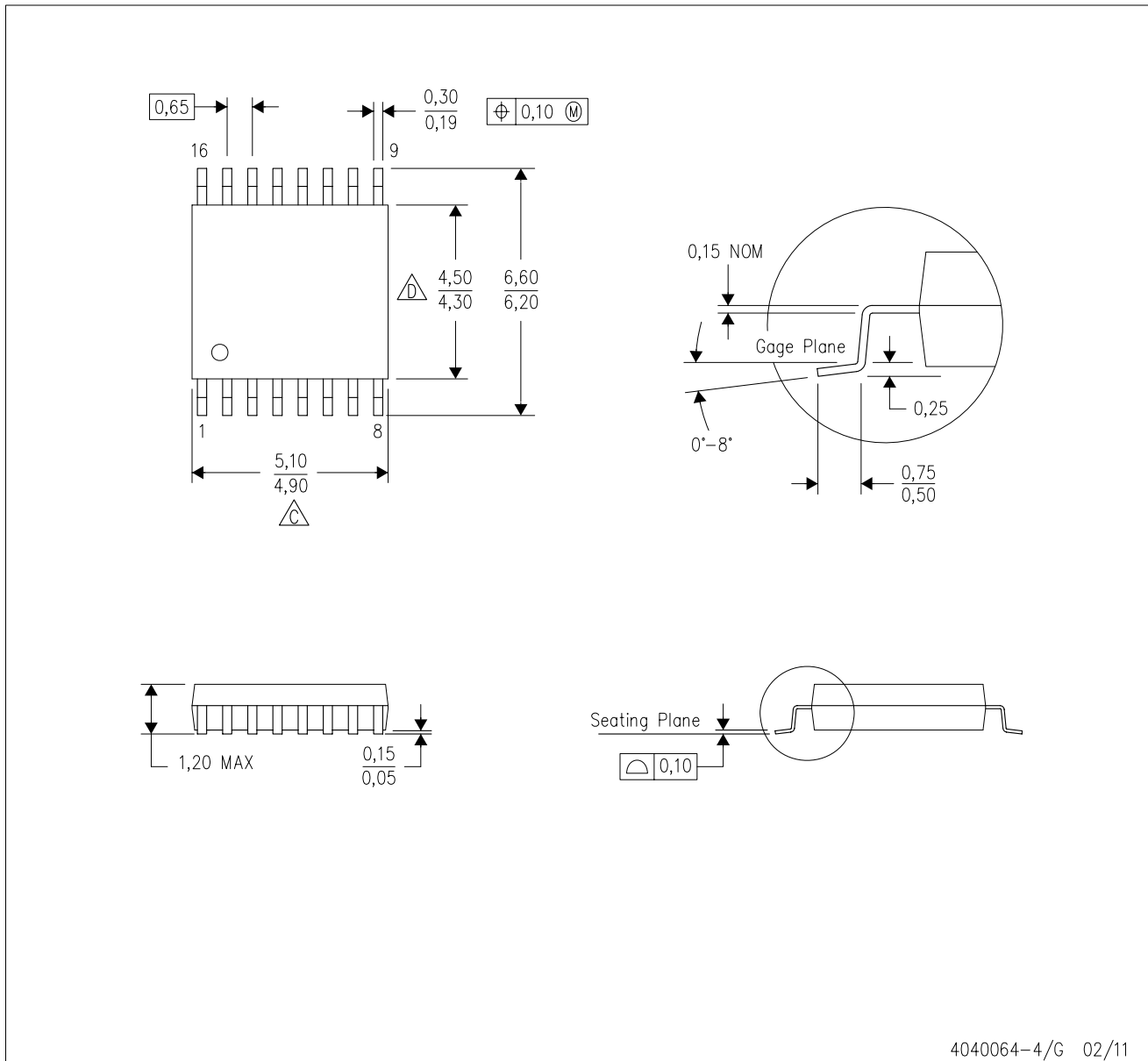


4073251/E 08/00

- NOTES: A. All linear dimensions are in millimeters.  
 B. This drawing is subject to change without notice.  
 C. Body dimensions do not include mold flash or protrusion, not to exceed 0,15 per side.  
 D. Falls within JEDEC: 24/48 Pins – MO-153  
 14/16/20/56 Pins – MO-194

PW (R-PDSO-G16)

PLASTIC SMALL OUTLINE

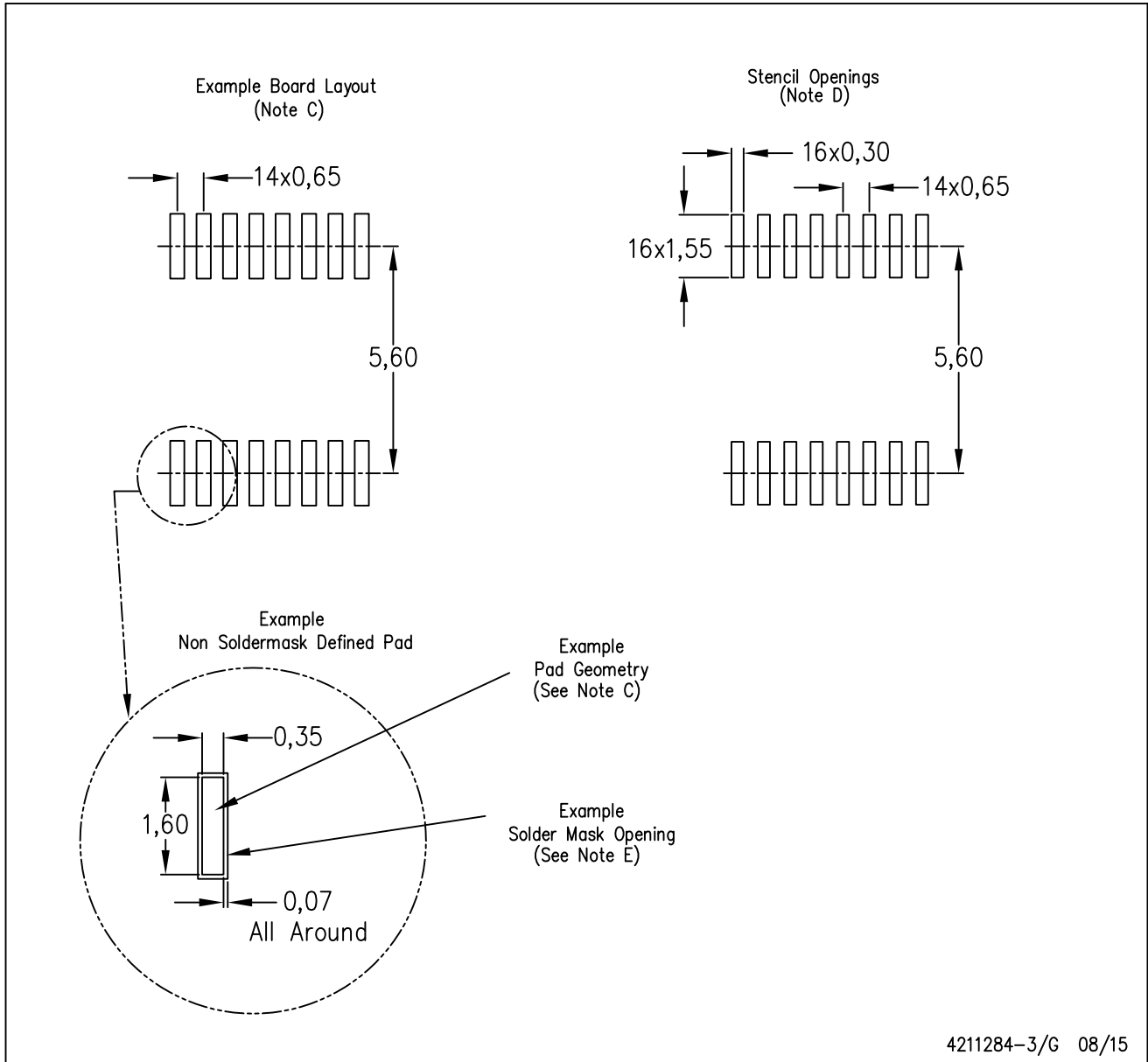


4040064-4/G 02/11

- NOTES:
- A. All linear dimensions are in millimeters. Dimensioning and tolerancing per ASME Y14.5M-1994.
  - B. This drawing is subject to change without notice.
  - C. Body length does not include mold flash, protrusions, or gate burrs. Mold flash, protrusions, or gate burrs shall not exceed 0,15 each side.
  - D. Body width does not include interlead flash. Interlead flash shall not exceed 0,25 each side.
  - E. Falls within JEDEC MO-153

PW (R-PDSO-G16)

PLASTIC SMALL OUTLINE



- NOTES:
- All linear dimensions are in millimeters.
  - This drawing is subject to change without notice.
  - Publication IPC-7351 is recommended for alternate designs.
  - Laser cutting apertures with trapezoidal walls and also rounding corners will offer better paste release. Customers should contact their board assembly site for stencil design recommendations. Refer to IPC-7525 for other stencil recommendations.
  - Customers should contact their board fabrication site for solder mask tolerances between and around signal pads.

**GENERIC PACKAGE VIEW**

**DBQ 16**

**SSOP - 1.75 mm max height**

SHRINK SMALL-OUTLINE PACKAGE



Images above are just a representation of the package family, actual package may vary.  
Refer to the product data sheet for package details.

4073301-2/1

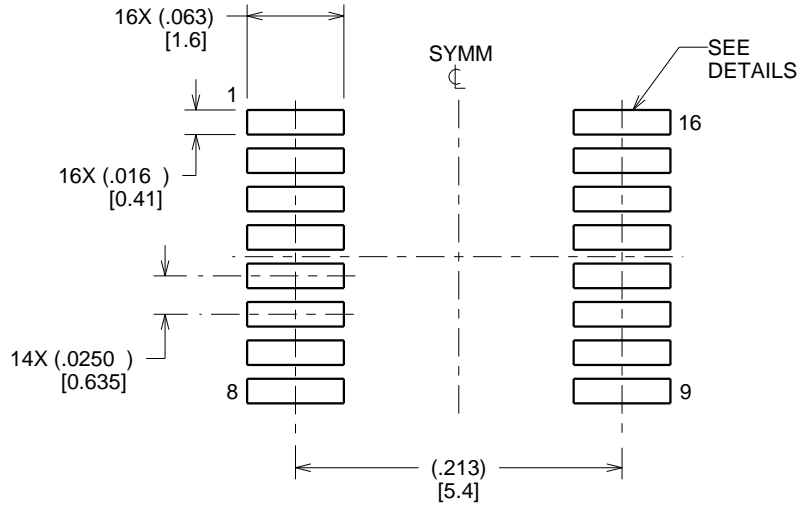


# EXAMPLE BOARD LAYOUT

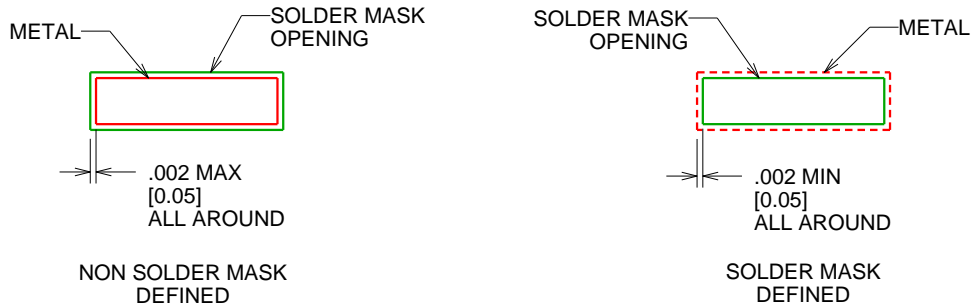
DBQ0016A

SSOP - 1.75 mm max height

SHRINK SMALL-OUTLINE PACKAGE



LAND PATTERN EXAMPLE  
SCALE:8X



SOLDER MASK DETAILS

4214846/A 03/2014

NOTES: (continued)

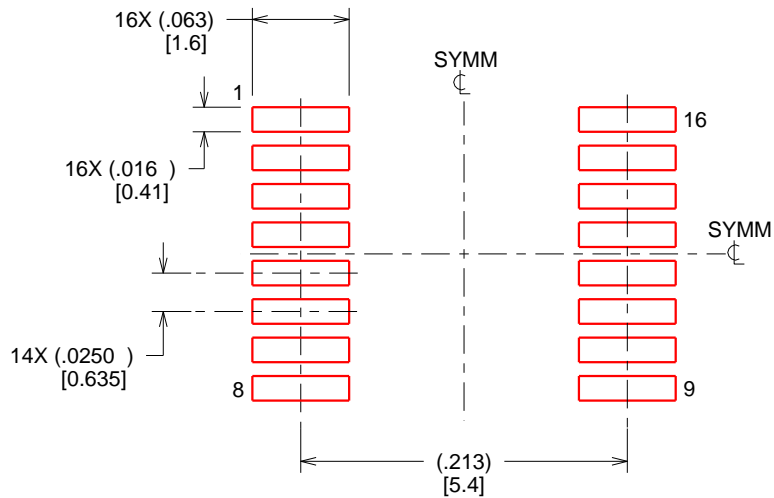
- 6. Publication IPC-7351 may have alternate designs.
- 7. Solder mask tolerances between and around signal pads can vary based on board fabrication site.

# EXAMPLE STENCIL DESIGN

DBQ0016A

SSOP - 1.75 mm max height

SHRINK SMALL-OUTLINE PACKAGE



SOLDER PASTE EXAMPLE  
BASED ON .005 INCH [0.127 MM] THICK STENCIL  
SCALE:8X

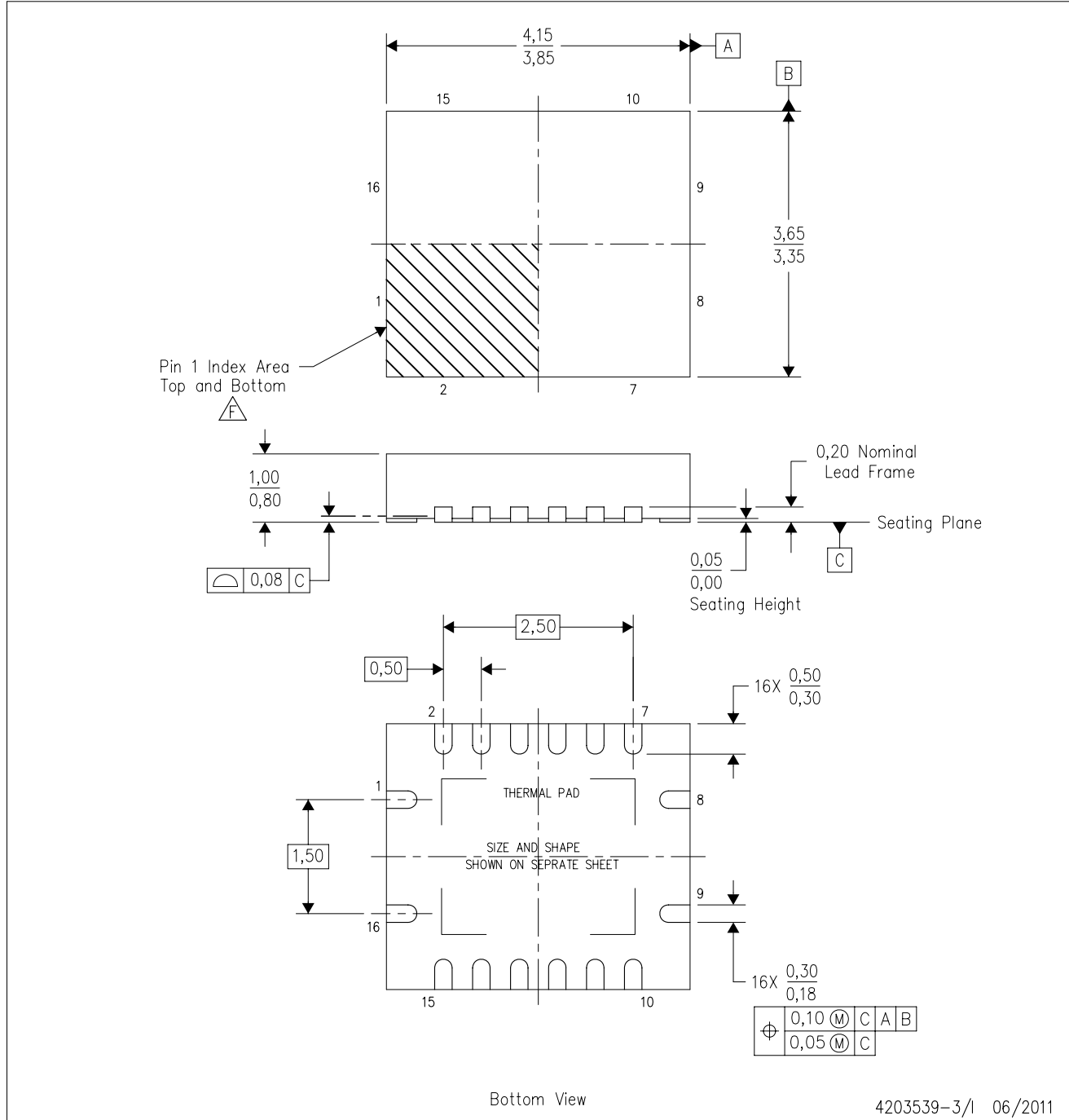
4214846/A 03/2014

NOTES: (continued)

8. Laser cutting apertures with trapezoidal walls and rounded corners may offer better paste release. IPC-7525 may have alternate design recommendations.
9. Board assembly site may have different recommendations for stencil design.

RGY (R-PVQFN-N16)

PLASTIC QUAD FLATPACK NO-LEAD



- NOTES:
- A. All linear dimensions are in millimeters. Dimensioning and tolerancing per ASME Y14.5M-1994.
  - B. This drawing is subject to change without notice.
  - C. QFN (Quad Flatpack No-Lead) package configuration.
  - D. The package thermal pad must be soldered to the board for thermal and mechanical performance.
  - E. See the additional figure in the Product Data Sheet for details regarding the exposed thermal pad features and dimensions.
  - F. Pin 1 identifiers are located on both top and bottom of the package and within the zone indicated. The Pin 1 identifiers are either a molded, marked, or metal feature.
  - G. Package complies to JEDEC MO-241 variation BA.

RGY (R-PVQFN-N16)

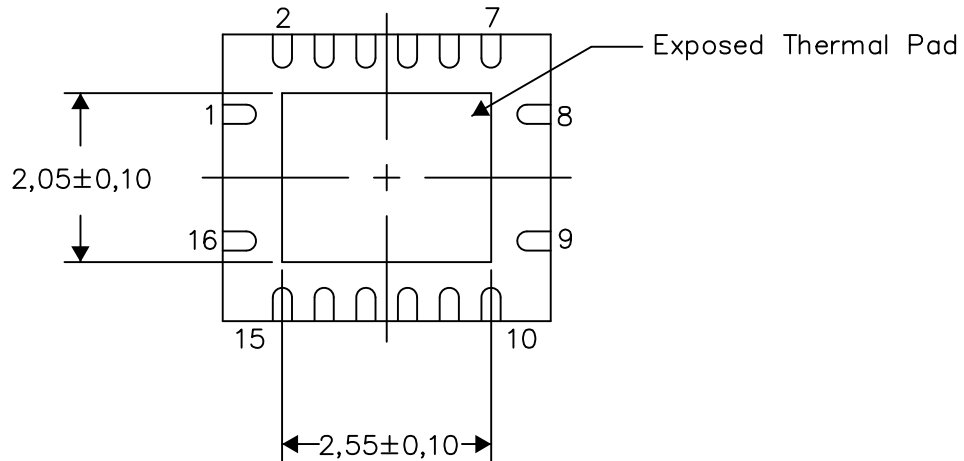
PLASTIC QUAD FLATPACK NO-LEAD

**THERMAL INFORMATION**

This package incorporates an exposed thermal pad that is designed to be attached directly to an external heatsink. The thermal pad must be soldered directly to the printed circuit board (PCB). After soldering, the PCB can be used as a heatsink. In addition, through the use of thermal vias, the thermal pad can be attached directly to the appropriate copper plane shown in the electrical schematic for the device, or alternatively, can be attached to a special heatsink structure designed into the PCB. This design optimizes the heat transfer from the integrated circuit (IC).

For information on the Quad Flatpack No-Lead (QFN) package and its advantages, refer to Application Report, QFN/SON PCB Attachment, Texas Instruments Literature No. SLUA271. This document is available at [www.ti.com](http://www.ti.com).

The exposed thermal pad dimensions for this package are shown in the following illustration.



Bottom View

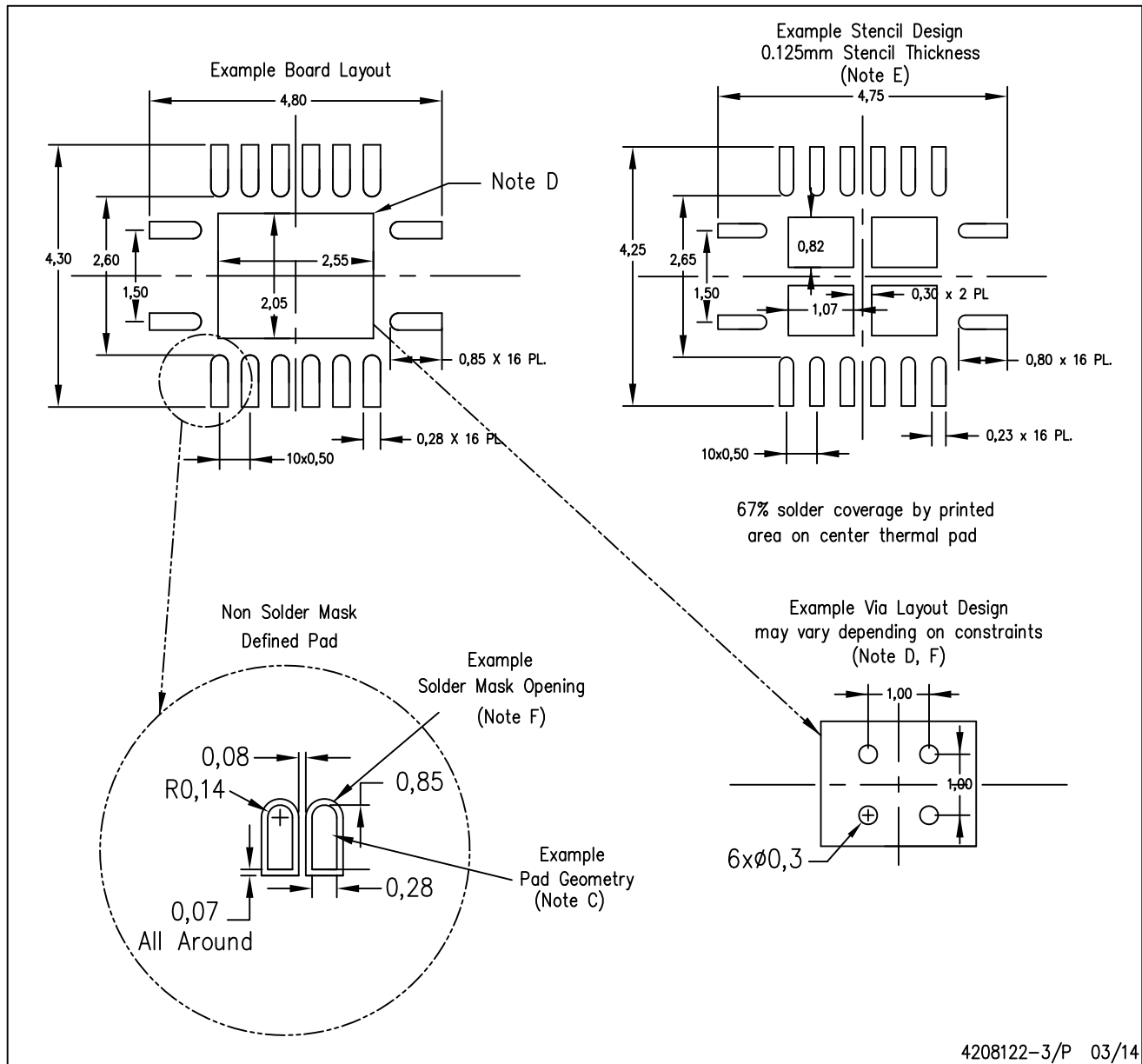
Exposed Thermal Pad Dimensions

4206353-3/P 03/14

NOTE: All linear dimensions are in millimeters

RGY (R-PVQFN-N16)

PLASTIC QUAD FLATPACK NO-LEAD

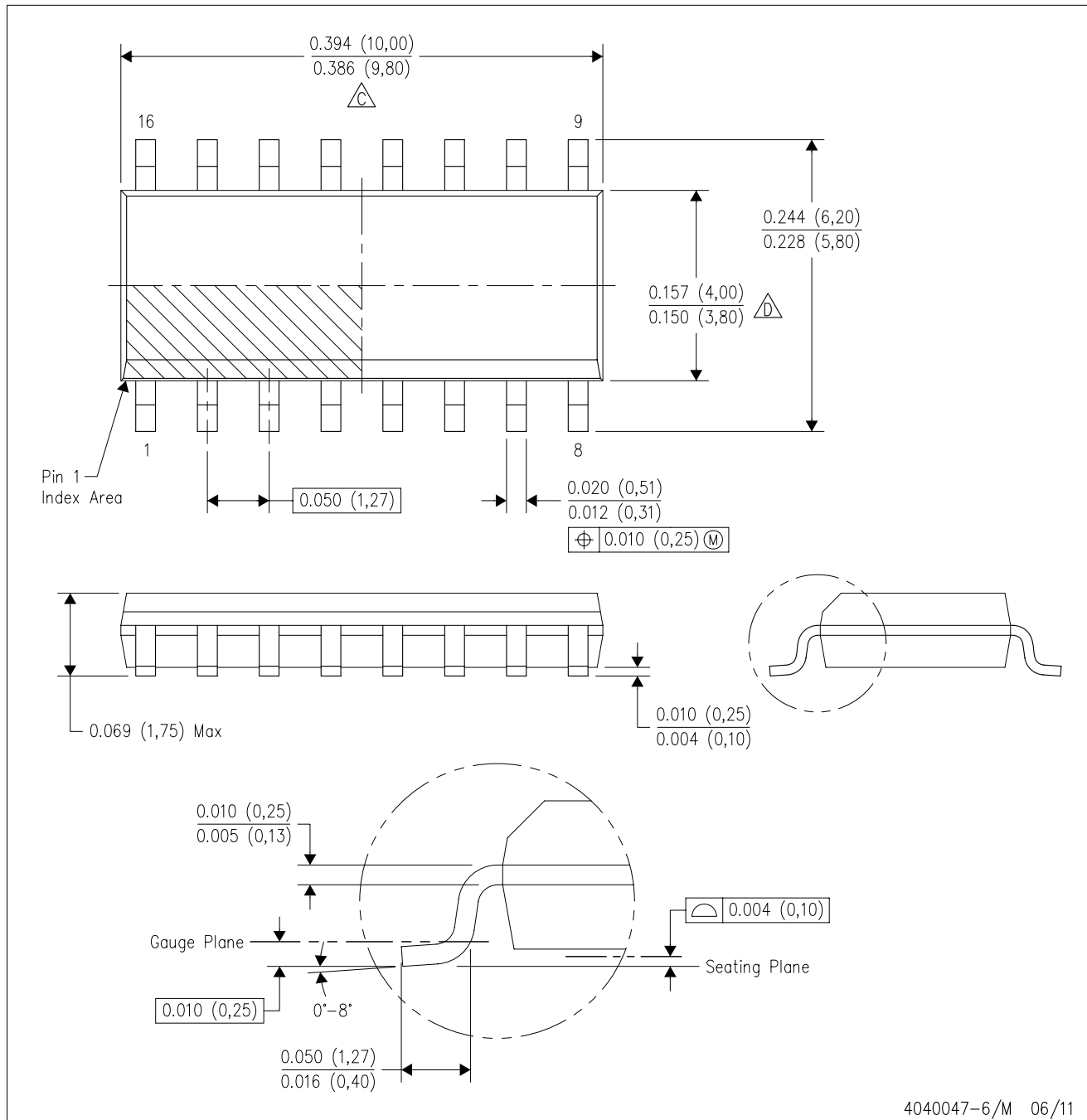


4208122-3/P 03/14

- NOTES:
- A. All linear dimensions are in millimeters.
  - B. This drawing is subject to change without notice.
  - C. Publication IPC-7351 is recommended for alternate designs.
  - D. This package is designed to be soldered to a thermal pad on the board. Refer to Application Note, Quad Flat-Pack QFN/SON PCB Attachment, Texas Instruments Literature No. SLUA271, and also the Product Data Sheets for specific thermal information, via requirements, and recommended board layout. These documents are available at [www.ti.com](http://www.ti.com) <<http://www.ti.com>>.
  - E. Laser cutting apertures with trapezoidal walls and also rounding corners will offer better paste release. Customers should contact their board assembly site for stencil design recommendations. Refer to IPC 7525 for stencil design considerations.
  - F. Customers should contact their board fabrication site for minimum solder mask web tolerances between signal pads.

D (R-PDSO-G16)

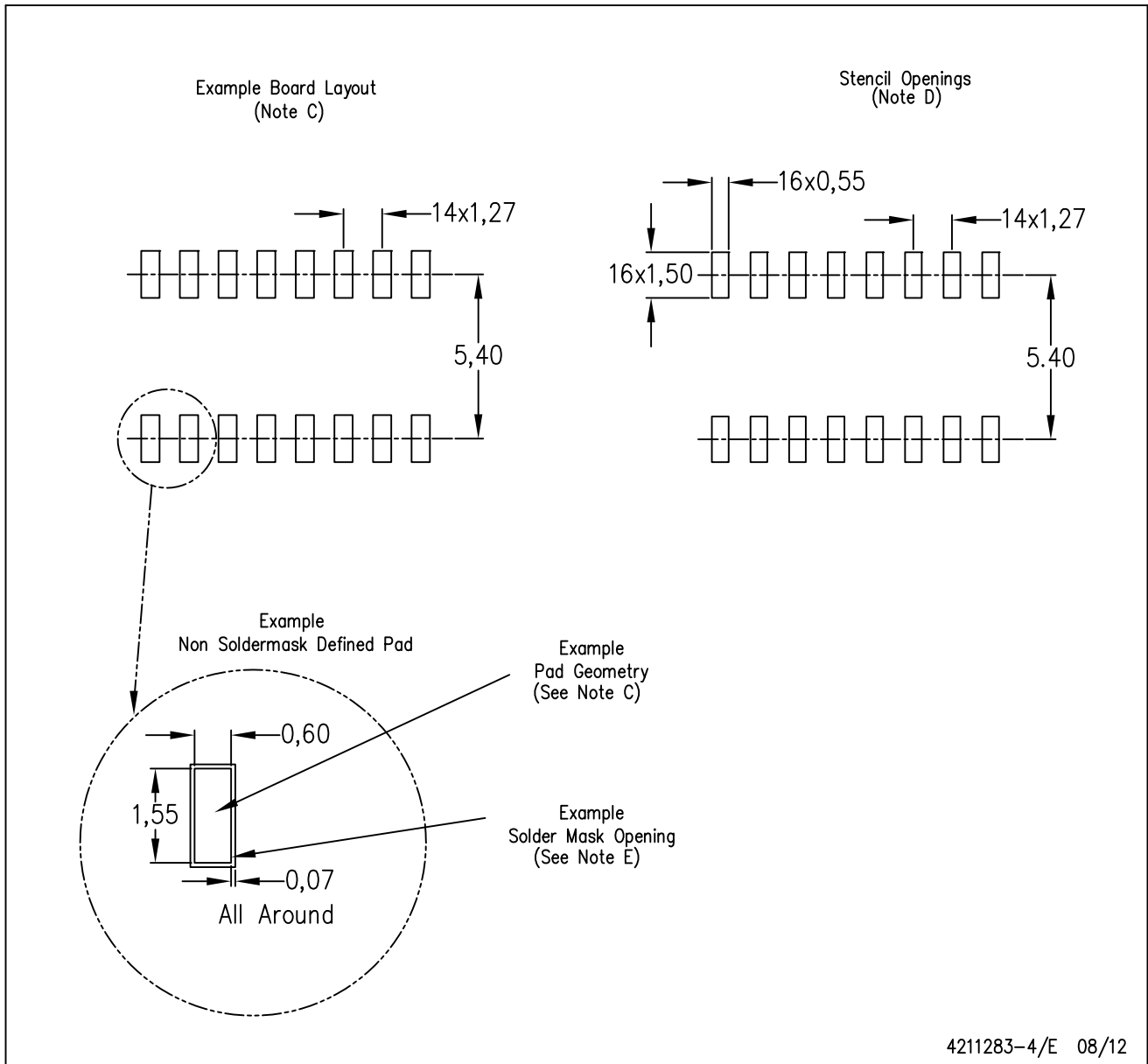
PLASTIC SMALL OUTLINE



- NOTES:
- A. All linear dimensions are in inches (millimeters).
  - B. This drawing is subject to change without notice.
  - C. Body length does not include mold flash, protrusions, or gate burrs. Mold flash, protrusions, or gate burrs shall not exceed 0.006 (0,15) each side.
  - D. Body width does not include interlead flash. Interlead flash shall not exceed 0.017 (0,43) each side.
  - E. Reference JEDEC MS-012 variation AC.

D (R-PDSO-G16)

PLASTIC SMALL OUTLINE



- NOTES:
- A. All linear dimensions are in millimeters.
  - B. This drawing is subject to change without notice.
  - C. Publication IPC-7351 is recommended for alternate designs.
  - D. Laser cutting apertures with trapezoidal walls and also rounding corners will offer better paste release. Customers should contact their board assembly site for stencil design recommendations. Refer to IPC-7525 for other stencil recommendations.
  - E. Customers should contact their board fabrication site for solder mask tolerances between and around signal pads.

## IMPORTANT NOTICE

Texas Instruments Incorporated (TI) reserves the right to make corrections, enhancements, improvements and other changes to its semiconductor products and services per JESD46, latest issue, and to discontinue any product or service per JESD48, latest issue. Buyers should obtain the latest relevant information before placing orders and should verify that such information is current and complete.

TI's published terms of sale for semiconductor products (<http://www.ti.com/sc/docs/stdterms.htm>) apply to the sale of packaged integrated circuit products that TI has qualified and released to market. Additional terms may apply to the use or sale of other types of TI products and services.

Reproduction of significant portions of TI information in TI data sheets is permissible only if reproduction is without alteration and is accompanied by all associated warranties, conditions, limitations, and notices. TI is not responsible or liable for such reproduced documentation. Information of third parties may be subject to additional restrictions. Resale of TI products or services with statements different from or beyond the parameters stated by TI for that product or service voids all express and any implied warranties for the associated TI product or service and is an unfair and deceptive business practice. TI is not responsible or liable for any such statements.

Buyers and others who are developing systems that incorporate TI products (collectively, "Designers") understand and agree that Designers remain responsible for using their independent analysis, evaluation and judgment in designing their applications and that Designers have full and exclusive responsibility to assure the safety of Designers' applications and compliance of their applications (and of all TI products used in or for Designers' applications) with all applicable regulations, laws and other applicable requirements. Designer represents that, with respect to their applications, Designer has all the necessary expertise to create and implement safeguards that (1) anticipate dangerous consequences of failures, (2) monitor failures and their consequences, and (3) lessen the likelihood of failures that might cause harm and take appropriate actions. Designer agrees that prior to using or distributing any applications that include TI products, Designer will thoroughly test such applications and the functionality of such TI products as used in such applications.

TI's provision of technical, application or other design advice, quality characterization, reliability data or other services or information, including, but not limited to, reference designs and materials relating to evaluation modules, (collectively, "TI Resources") are intended to assist designers who are developing applications that incorporate TI products; by downloading, accessing or using TI Resources in any way, Designer (individually or, if Designer is acting on behalf of a company, Designer's company) agrees to use any particular TI Resource solely for this purpose and subject to the terms of this Notice.

TI's provision of TI Resources does not expand or otherwise alter TI's applicable published warranties or warranty disclaimers for TI products, and no additional obligations or liabilities arise from TI providing such TI Resources. TI reserves the right to make corrections, enhancements, improvements and other changes to its TI Resources. TI has not conducted any testing other than that specifically described in the published documentation for a particular TI Resource.

Designer is authorized to use, copy and modify any individual TI Resource only in connection with the development of applications that include the TI product(s) identified in such TI Resource. NO OTHER LICENSE, EXPRESS OR IMPLIED, BY ESTOPPEL OR OTHERWISE TO ANY OTHER TI INTELLECTUAL PROPERTY RIGHT, AND NO LICENSE TO ANY TECHNOLOGY OR INTELLECTUAL PROPERTY RIGHT OF TI OR ANY THIRD PARTY IS GRANTED HEREIN, including but not limited to any patent right, copyright, mask work right, or other intellectual property right relating to any combination, machine, or process in which TI products or services are used. Information regarding or referencing third-party products or services does not constitute a license to use such products or services, or a warranty or endorsement thereof. Use of TI Resources may require a license from a third party under the patents or other intellectual property of the third party, or a license from TI under the patents or other intellectual property of TI.

TI RESOURCES ARE PROVIDED "AS IS" AND WITH ALL FAULTS. TI DISCLAIMS ALL OTHER WARRANTIES OR REPRESENTATIONS, EXPRESS OR IMPLIED, REGARDING RESOURCES OR USE THEREOF, INCLUDING BUT NOT LIMITED TO ACCURACY OR COMPLETENESS, TITLE, ANY EPIDEMIC FAILURE WARRANTY AND ANY IMPLIED WARRANTIES OF MERCHANTABILITY, FITNESS FOR A PARTICULAR PURPOSE, AND NON-INFRINGEMENT OF ANY THIRD PARTY INTELLECTUAL PROPERTY RIGHTS. TI SHALL NOT BE LIABLE FOR AND SHALL NOT DEFEND OR INDEMNIFY DESIGNER AGAINST ANY CLAIM, INCLUDING BUT NOT LIMITED TO ANY INFRINGEMENT CLAIM THAT RELATES TO OR IS BASED ON ANY COMBINATION OF PRODUCTS EVEN IF DESCRIBED IN TI RESOURCES OR OTHERWISE. IN NO EVENT SHALL TI BE LIABLE FOR ANY ACTUAL, DIRECT, SPECIAL, COLLATERAL, INDIRECT, PUNITIVE, INCIDENTAL, CONSEQUENTIAL OR EXEMPLARY DAMAGES IN CONNECTION WITH OR ARISING OUT OF TI RESOURCES OR USE THEREOF, AND REGARDLESS OF WHETHER TI HAS BEEN ADVISED OF THE POSSIBILITY OF SUCH DAMAGES.

Unless TI has explicitly designated an individual product as meeting the requirements of a particular industry standard (e.g., ISO/TS 16949 and ISO 26262), TI is not responsible for any failure to meet such industry standard requirements.

Where TI specifically promotes products as facilitating functional safety or as compliant with industry functional safety standards, such products are intended to help enable customers to design and create their own applications that meet applicable functional safety standards and requirements. Using products in an application does not by itself establish any safety features in the application. Designers must ensure compliance with safety-related requirements and standards applicable to their applications. Designer may not use any TI products in life-critical medical equipment unless authorized officers of the parties have executed a special contract specifically governing such use. Life-critical medical equipment is medical equipment where failure of such equipment would cause serious bodily injury or death (e.g., life support, pacemakers, defibrillators, heart pumps, neurostimulators, and implantables). Such equipment includes, without limitation, all medical devices identified by the U.S. Food and Drug Administration as Class III devices and equivalent classifications outside the U.S.

TI may expressly designate certain products as completing a particular qualification (e.g., Q100, Military Grade, or Enhanced Product). Designers agree that it has the necessary expertise to select the product with the appropriate qualification designation for their applications and that proper product selection is at Designers' own risk. Designers are solely responsible for compliance with all legal and regulatory requirements in connection with such selection.

Designer will fully indemnify TI and its representatives against any damages, costs, losses, and/or liabilities arising out of Designer's non-compliance with the terms and provisions of this Notice.