

TP3069 "Enhanced" Serial Interface CMOS CODEC/Filter COMBO®

General Description

The TP3069 (A-law) is a monolithic PCM CODEC/Filter utilizing the A/D and D/A conversion architecture shown in Figure 1, and a serial PCM interface. The device is fabricated using National's advanced double-poly CMOS process (microCMOS).

Similar to the TP305X family, this device features an additional Receive Power Amplifier to provide push-pull balanced output drive capability. The receive gain can be adjusted by means of two external resistors for an output level of up to $\pm 6.6V$ across a balanced 600Ω load.

Also included is an Analog Loopback switch and a \overline{TS}_X output.

Note: See also AN-370, "Techniques for Designing with CODEC/Filter COMBO Circuits."

Features

- Complete CODEC and filtering system including:
 - Transmit high-pass and low-pass filtering
 - Receive low-pass filter with $\sin x/x$ correction
 - Active RC noise filters
 - A-law compatible COder and DECoder
 - Internal precision voltage reference
 - Serial I/O interface
 - Internal auto-zero circuitry
 - Receive push-pull power amplifiers
- Designed for D3/D4 and CCITT applications
- $\pm 5V$ operation
- Low operating power—typically 70 mW
- Power-down standby mode—typically 3 mW
- Automatic power-down
- TTL or CMOS compatible digital interfaces
- Maximizes line interface card circuit density

COMBO® and TRI-STATE® are registered trademarks of National Semiconductor Corp.

Block Diagram

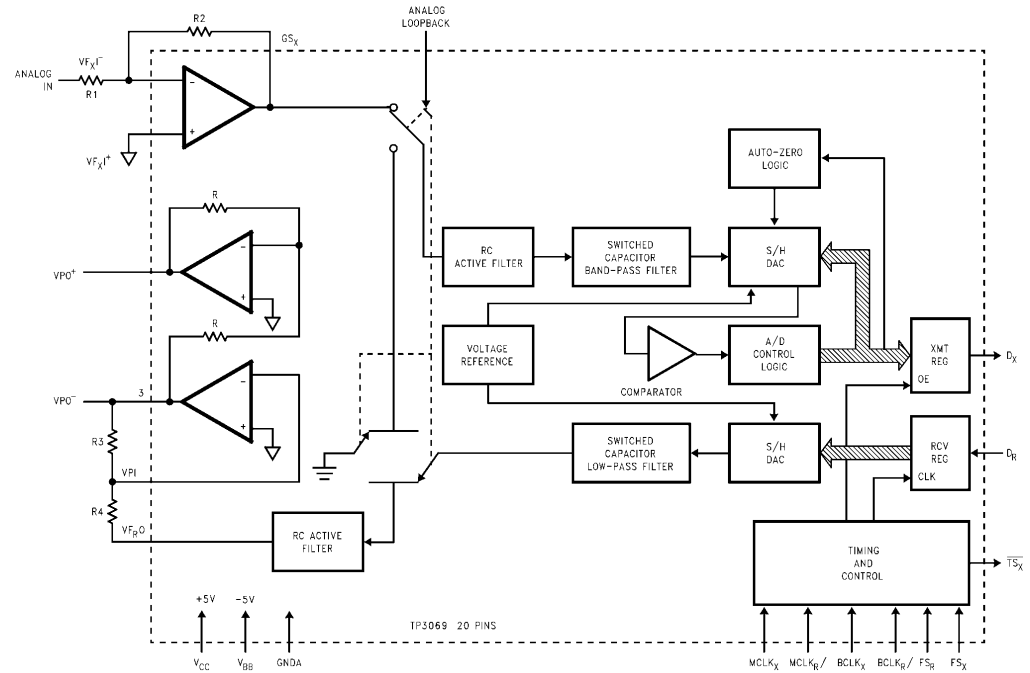
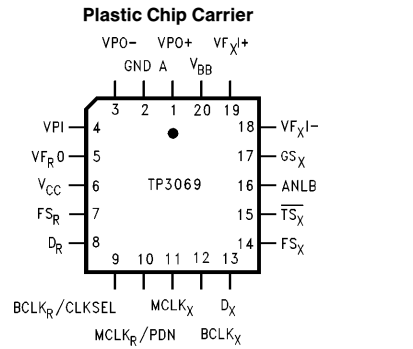
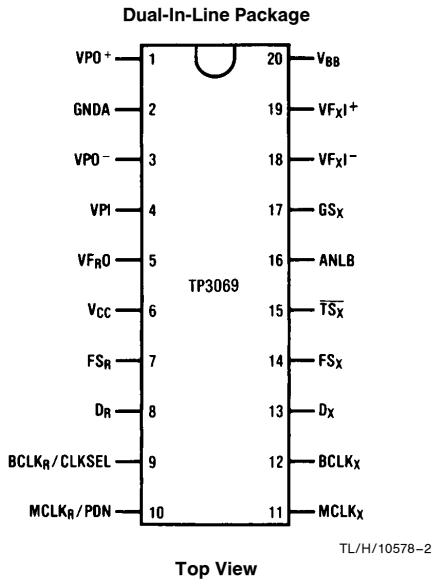

FIGURE 1

TP3069 "Enhanced" Serial Interface CMOS CODEC/Filter COMBO

Connection Diagrams



Order Number TP3069J
See NS Package Number J20A

Order Number TP3069N
See NS Package Number N20A

Order Number TP3069V
See NS Package Number V20A

Order Number TP3069WM
See NS Package Number M20B

Pin Description

Symbol	Function	Symbol	Function
VPO ⁺	The non-inverted output of the receive power amplifier.	MCLK _X	Transmit master clock. Must be 1.536 MHz, 1.544 MHz or 2.048 MHz. May be asynchronous with MCLK _R . Best performance is realized from synchronous operation.
GNDA	Analog ground. All signals are referenced to this pin.	BCLK _X	The bit clock which shifts out the PCM data on D _X . May vary from 64 kHz to 2.048 MHz, but must be synchronous with MCLK _X .
VPO ⁻	The inverted output of the receive power amplifier.	D _X	The TRI-STATE [®] PCM data output which is enabled by FS _X .
VPI	Inverting input to the receive power amplifier.	FS _X	Transmit frame sync pulse input which enables BCLK _X to shift out the PCM data on D _X . FS _X is an 8 kHz pulse train, see <i>Figures 2</i> and <i>3</i> for timing details.
VFR0	Analog output of the receive filter.	\overline{TS}_X	Open drain output which pulses low during the encoder time slot.
VCC	Positive power supply pin. V _{CC} = +5V ± 5%.	ANLB	Analog Loopback control input. Must be set to logic '0' for normal operation. When pulled to logic '1', the transmit filter input is disconnected from the output of the transmit preamplifier and connected to the output of the receive switched capacitor low-pass filter and the input to the receive RC active filter is connected to ground. This results in the VFRO output being at ground level during analog loopback operation.
FSR	Receive frame sync pulse which enables BCLK _R to shift PCM data into D _R . FSR is an 8 kHz pulse train. See <i>Figures 2</i> and <i>3</i> for timing details.	GS _X	Analog output of the transmit input amplifier. Used to externally set gain.
DR	Receive data input. PCM data is shifted into D _R following the FSR leading edge.	VFxI ⁻	Inverting input of the transmit input amplifier.
BCLK _R /CLKSEL	The bit clock which shifts data into D _R after the FSR leading edge. May vary from 64 kHz to 2.048 MHz. Alternatively, may be a logic input which selects either 1.536 MHz/1.544 MHz or 2.048 MHz for master clock in synchronous mode and BCLK _X is used for both transmit and receive directions (see Table I).	VFxI ⁺	Non-inverting input of the transmit input amplifier.
MCLK _R /PDN	Receive master clock. Must be 1.536 MHz, 1.544 MHz or 2.048 MHz. May be asynchronous with MCLK _X , but should be synchronous with MCLK _X for best performance. When MCLK _R is connected continuously low, MCLK _X is selected for all internal timing. When MCLK _R is connected continuously high, the device is powered down.	VBB	Negative power supply pin. V _{BB} = -5V ± 5%.

Functional Description

POWER-UP

When power is first applied, power-on reset circuitry initializes the COMBO™ and places it into a power-down state. All non-essential circuits are deactivated and the D_X , V_{FRO} , V_{PO-} and V_{PO+} outputs are put in high impedance states. To power-up the device, a logical low level or clock must be applied to the $MCLK_R/$ PDN pin *and* FS_X and/or FS_R pulses must be present. Thus, 2 power-down control modes are available. The first is to pull the $MCLK_R/$ PDN pin high; the alternative is to hold both FS_X and FS_R inputs continuously low—the device will power-down approximately 1 ms after the last FS_X or FS_R pulse. Power-up will occur on the first FS_X or FS_R pulse. The TRI-STATE PCM data output, D_X , will remain in the high impedance state until the second FS_X pulse.

SYNCHRONOUS OPERATION

For synchronous operation, the same master clock and bit clock should be used for both the transmit and receive directions. In this mode, a clock must be applied to $MCLK_X$ and the $MCLK_R/$ PDN pin can be used as a power-down control. A low level on $MCLK_R/$ PDN powers up the device and a high level powers down the device. In either case, $MCLK_X$ will be selected as the master clock for both the transmit and receive circuits. A bit clock must also be applied to $BCLK_X$ and the $BCLK_R/$ CLKSEL can be used to select the proper internal divider for a master clock of 1.536 MHz, 1.544 MHz or 2.048 MHz. For 1.544 MHz operation, the device automatically compensates for the 193rd clock pulse each frame.

With a fixed level on the $BCLK_R/$ CLKSEL pin, $BCLK_X$ will be selected as the bit clock for both the transmit and receive directions. Table I indicates the frequencies of operation which can be selected, depending on the state of $BCLK_R/$ CLKSEL. In this synchronous mode, the bit clock, $BCLK_X$, may be from 64 kHz to 2.048 MHz, but must be synchronous with $MCLK_X$.

Each FS_X pulse begins the encoding cycle and the PCM data from the previous encode cycle is shifted out of the enabled D_X output on the positive edge of $BCLK_X$. After 8-bit clock periods, the TRI-STATE D_X output is returned to a high impedance state. With an FS_R pulse, PCM data is latched via the D_R input on the negative edge of $BCLK_X$ (or $BCLK_R$ if running). FS_X and FS_R must be synchronous with $MCLK_X/R$.

TABLE I. Selection of Master Clock Frequencies

BCLK _R /CLKSEL	Master Clock Frequency Selected
	TP3069
Clocked	2.048 MHz
0	1.536 MHz or 1.544 MHz
1	2.048 MHz

ASYNCHRONOUS OPERATION

For asynchronous operation, separate transmit and receive clocks may be applied. $MCLK_X$ and $MCLK_R$ must be 2.048 MHz and need not be synchronous. For best trans-

mission performance, however, $MCLK_R$ should be synchronous with $MCLK_X$, which is easily achieved by applying only static logic levels to the $MCLK_R/$ PDN pin. This will automatically connect $MCLK_X$ to all internal $MCLK_R$ functions (see Pin Description). For 1.544 MHz operation, the device automatically compensates for the 193rd clock pulse each frame. FS_X starts each encoding cycle and must be synchronous with $MCLK_X$ and $BCLK_X$. FS_R starts each decoding cycle and must be synchronous with $BCLK_R$. $BCLK_R$ must be a clock, the logic levels shown in Table I are not valid in asynchronous mode. $BCLK_X$ and $BCLK_R$ may operate from 64 kHz to 2.048 MHz.

SHORT FRAME SYNC OPERATION

The COMBO can utilize either a short frame sync pulse or a long frame sync pulse. Upon power initialization, the device assumes a short frame mode. In this mode, both frame sync pulses, FS_X and FS_R , must be one bit clock period long, with timing relationships specified in Figure 2. With FS_X high during a falling edge of $BCLK_X$, the next rising edge of $BCLK_X$ enables the D_X TRI-STATE output buffer, which will output the sign bit. The following seven rising edges clock out the remaining seven bits, and the next falling edge disables the D_X output. With FS_R high during a falling edge of $BCLK_R$ ($BCLK_X$ in synchronous mode), the next falling edge of $BCLK_R$ latches in the sign bit. The following seven falling edges latch in the seven remaining bits. All devices may utilize the short frame sync pulse in synchronous or asynchronous operating mode.

LONG FRAME SYNC OPERATION

To use the long frame mode, both the frame sync pulses, FS_X and FS_R , must be three or more bit clock periods long, with timing relationships specified in Figure 3. Based on the transmit frame sync, FS_X , the COMBO will sense whether short or long frame sync pulses are being used. For 64 kHz operation, the frame sync pulse must be kept low for a minimum of 160 ns. The D_X TRI-STATE output buffer is enabled with the rising edge of FS_X or the rising edge of $BCLK_X$, whichever comes later, and the first bit clocked out is the sign bit. The following seven $BCLK_X$ rising edges clock out the remaining seven bits. The D_X output is disabled by the falling $BCLK_X$ edge following the eighth rising edge, or by FS_X going low, whichever comes later. A rising edge on the receive frame sync pulse, FS_R , will cause the PCM data at D_R to be latched in on the next eight falling edges of $BCLK_R$ ($BCLK_X$ in synchronous mode). All devices may utilize the long frame sync pulse in synchronous or asynchronous mode.

TRANSMIT SECTION

The transmit section input is an operational amplifier with provision for gain adjustment using two external resistors, see Figure 4. The low noise and wide bandwidth allow gains in excess of 20 dB across the audio passband to be realized. The op amp drives a unity-gain filter consisting of RC active pre-filter, followed by an eighth order switched-capacitor bandpass filter clocked at 256 kHz. The output of this filter directly drives the encoder sample-and-hold circuit. The A/D is of companding type according to A-law coding conventions. A precision voltage reference is trimmed in manufacturing to provide an input overload (I_{MAX}) of nominally 2.5V peak (see table of Transmission Characteristics).

Functional Description (Continued)

The FS_X frame sync pulse controls the sampling of the filter output, and then the successive-approximation encoding cycle begins. The 8-bit code is then loaded into a buffer and shifted out through D_X at the next FS_X pulse. The total encoding delay will be approximately $165 \mu s$ (due to the transmit filter) plus $125 \mu s$ (due to encoding delay), which totals $290 \mu s$. Any offset voltage due to the filters or comparator is cancelled by sign bit integration.

RECEIVE SECTION

The receive section consists of an expanding DAC which drives a fifth order switched-capacitor low pass filter clocked at 256 kHz. The decoder is A-law and the 5th order low pass filter corrects for the $\sin x/x$ attenuation due to the 8 kHz sample/hold. The filter is then followed by a 2nd order RC active post-filter with its output at VF_{RO} . The receive section is unity-gain, but gain can be added by using the power amplifiers. Upon the occurrence of FS_R , the data at the D_R input is clocked in on the falling edge of the next eight $BCLK_R$ ($BCLK_X$) periods. At the end of the decoder time slot, the decoding cycle begins, and $10 \mu s$ later the decoder DAC output is updated. The total decoder delay is $\sim 10 \mu s$ (decoder update) plus $110 \mu s$ (filter delay) plus $62.5 \mu s$ ($1/2$ frame), which gives approximately $180 \mu s$.

RECEIVE POWER AMPLIFIERS

Two inverting mode power amplifiers are provided for directly driving a matched line interface transformer. The gain of the first power amplifier can be adjusted to boost the $\pm 2.5V$ peak output signal from the receive filter up to $\pm 3.3V$ peak into an unbalanced 300Ω load, or $\pm 4.0V$ into an unbalanced $15 k\Omega$ load. The second power amplifier is internally connected in unity-gain inverting mode to give 6 dB of signal gain for balanced loads.

Maximum power transfer to a 600Ω subscriber line termination is obtained by differentially driving a balanced transformer with a $\sqrt{2}:1$ turns ratio, as shown in *Figure 4*. A total peak power of 15.6 dBm can be delivered to the load plus termination.

ENCODING FORMAT AT D_X OUTPUT

	TP3069 A-Law (Includes Even Bit Inversion)							
$V_{IN} = +\text{Full-Scale}$	1	0	1	0	1	0	1	0
$V_{IN} = 0V$	1	1	0	1	0	1	0	1
	0	1	0	1	0	1	0	1
$V_{IN} = -\text{Full-Scale}$	0	0	1	0	1	0	1	0

Absolute Maximum Ratings

If Military/Aerospace specified devices are required, please contact the National Semiconductor Sales Office/Distributors for availability and specifications.

V_{CC} to GNDA	7V
V_{BB} to GNDA	-7V
Voltage at any Analog Input or Output	$V_{CC} + 0.3V$ to $V_{BB} - 0.3V$

Voltage at any Digital Input or Output	$V_{CC} + 0.3V$ to $GNDA - 0.3V$
Operating Temperature Range	-25°C to +125°C
Storage Temperature Range	-65°C to +150°C
Lead Temp. (Soldering, 10 sec.)	300°C
ESD (Human Body Model) J	1000V
ESD (Human Body Model) N	1500V
Latch-Up Immunity on Any Pin	100 mA

Electrical Characteristics Unless otherwise noted, limits printed in **BOLD** characters are guaranteed for $V_{CC} = +5.0V \pm 5\%$, $V_{BB} = -5.0V \pm 5\%$; $T_A = 0^\circ C$ to $70^\circ C$ by correlation with 100% electrical testing at $T_A = 25^\circ C$. All other limits are assured by correlation with other production tests and/or product design and characterization. All signals referenced to GNDA. Typicals specified at $V_{CC} = +5.0V$, $V_{BB} = -5.0V$, $T_A = 25^\circ C$.

Symbol	Parameter	Conditions	Min	Typ	Max	Units
POWER DISSIPATION (ALL DEVICES)						
I_{CC0}	Power-Down Current	(Note †)		0.5	1.5	mA
I_{BB0}	Power-Down Current	(Note †)		0.05	0.3	mA
I_{CC1}	Active Current	$V_{PI} = 0V$; V_{FRO} , V_{PO}^+ and V_{PO}^- unloaded		7.0	10.0	mA
I_{BB1}	Active Current	$V_{PI} = 0V$; V_{FRO} , V_{PO}^+ and V_{PO}^- unloaded		7.0	10.0	mA
DIGITAL INTERFACE						
V_{IL}	Input Low Voltage				0.6	V
V_{IH}	Input High Voltage		2.2			V
V_{OL}	Output Low Voltage	D_X , $I_L = 3.2$ mA			0.4	V
		\overline{TS}_X , $I_L = 3.2$ mA, Open Drain			0.4	V
V_{OH}	Output High Voltage	D_X , $I_H = -3.2$ mA	2.4			V
I_{IL}	Input Low Current	$GNDA \leq V_{IN} \leq V_{IL}$, All Digital Inputs	-10		10	μA
I_{IH}	Input High Current	$V_{IH} \leq V_{IN} \leq V_{CC}$	-10		10	μA
I_{OZ}	Output Current in High Impedance State (TRI-STATE)	D_X , $GNDA \leq V_O \leq V_{CC}$	-10		10	μA

Note †: I_{CC0} and I_{BB0} are measured after first achieving a power-up state.

Electrical Characteristics (Continued)

Unless otherwise noted, limits printed in **BOLD** characters are guaranteed for $V_{CC} = +5.0V \pm 5\%$, $V_{BB} = -5.0V \pm 5\%$; $T_A = 0^\circ\text{C}$ to 70°C by correlation with 100% electrical testing at $T_A = 25^\circ\text{C}$. All other limits are assured by correlation with other production tests and/or product design and characterization. All signals referenced to GNDA. Typical values specified at $V_{CC} = +5.0V$, $V_{BB} = -5.0V$, $T_A = 25^\circ\text{C}$.

Symbol	Parameter	Conditions	Min	Typ	Max	Units
ANALOG INTERFACE WITH TRANSMIT INPUT AMPLIFIER (ALL DEVICES)						
I_{IXA}	Input Leakage Current	$-2.5V \leq V \leq +2.5V$, V_{FXL}^+ or V_{FXL}^-	-200		200	nA
R_{IXA}	Input Resistance	$-2.5V \leq V \leq +2.5V$, V_{FXL}^+ or V_{FXL}^-	10			M Ω
R_{OXA}	Output Resistance	Closed Loop, Unity Gain		1	3	Ω
R_{LXA}	Load Resistance	GS_X	10			k Ω
C_{LXA}	Load Capacitance	GS_X			50	pF
V_{OXA}	Output Dynamic Range	GS_X , $R_L \geq 10$ k Ω	-2.8		+2.8	V
A_{VXA}	Voltage Gain	V_{FXL}^+ to GS_X	5000			V/V
F_{UXA}	Unity-Gain Bandwidth		1	2		MHz
V_{OSXA}	Offset Voltage		-20		20	mV
V_{CMXA}	Common-Mode Voltage	CMRRXA > 60 dB	-2.5		2.5	V
CMRRXA	Common-Mode Rejection Ratio	DC Test	60			dB
PSRRXA	Power Supply Rejection Ratio	DC Test	60			dB
ANALOG INTERFACE WITH RECEIVE FILTER (ALL DEVICES)						
R_{ORF}	Output Resistance	Pin V_{FR0}		1	3	Ω
R_{LRF}	Load Resistance	$V_{FR0} = \pm 2.5V$	10			k Ω
C_{LRF}	Load Capacitance	Connect from V_{FR0} to GNDA			25	pF
V_{OSR0}	Output DC Offset Voltage	Measure from V_{FR0} to GNDA	-200		200	mV
ANALOG INTERFACE WITH POWER AMPLIFIERS (ALL DEVICES)						
IPI	Input Leakage Current	$-1.0V \leq V_{PI} \leq 1.0V$	-100		100	nA
RIPi	Input Resistance	$-1.0V \leq V_{PI} \leq 1.0V$	10			M Ω
VIOS	Input Offset Voltage		-25		25	mV
ROP	Output Resistance	Inverting Unity-Gain at V_{PO}^+ or V_{PO}^-		1		Ω
F_C	Unity-Gain Bandwidth	Open Loop (V_{PO}^-)		400		kHz
C_{LP}	Load Capacitance				100	pF
GA_{P^+}	Gain from V_{PO}^- to V_{PO}^+	$R_L = 600\Omega$ V_{PO}^+ to V_{PO}^- Level at $V_{PO}^- = 1.77$ Vrms		-1		V/V
PSRR _P	Power Supply Rejection of V_{CC} or V_{BB}	V_{PO}^- Connected to VPI 0 kHz – 4 kHz 4 kHz – 50 kHz	60 36			dB dB
R_{LP}	Load Resistance	Connect from V_{PO}^+ to V_{PO}^-	600			Ω

Timing Specifications

Unless otherwise noted, limits printed in **BOLD** characters are guaranteed for $V_{CC} = +5.0V \pm 5\%$, $V_{BB} = -5.0V \pm 5\%$, $T_A = 0^\circ C$ to $70^\circ C$ by correlation with 100% electrical testing at $T_A = 25^\circ C$. All other limits are assured by correlation with other production tests and/or product design and characterization. All signals are referenced to GNDA. Typical values specified at $V_{CC} = +5.0V$, $V_{BB} = -5.0V$, $T_A = 25^\circ C$. All timing parameters are measured at $V_{OH} = 2.0V$ and $V_{OL} = 0.7V$.

See Definitions and Timing Conventions section for test methods information.

Symbol	Parameter	Conditions	Min	Typ	Max	Units
$1/t_{PM}$	Frequency of Master Clock	MCLK _X and MCLK _R		1.536 1.544 2.048		MHz MHz MHz
t_{RM}	Rise Time of Master Clock	MCLK _X and MCLK _R			50	ns
t_{FM}	Fall Time of Master Clock	MCLK _X and MCLK _R			50	ns
t_{PB}	Period of Bit Clock		485	488	15725	ns
t_{RB}	Rise Time of Bit Clock	BCLK _X and BCLK _R			50	ns
t_{FB}	Fall Time of Bit Clock	BCLK _X and BCLK _R			50	ns
t_{WMH}	Width of Master Clock High	MCLK _X and MCLK _R	160			ns
t_{WML}	Width of Master Clock Low	MCLK _X and MCLK _R	160			ns
t_{SBFM}	Set-Up Time from BCLK _X High to MCLK _X Falling Edge	First Bit Clock after the Leading Edge of FS _X	100			ns
t_{WBH}	Width of Bit Clock High		160			ns
t_{WBL}	Width of Bit Clock Low		160			ns
t_{HBFL}	Holding Time from Bit Clock Low to Frame Sync	Long Frame Only	0			ns
t_{HBFS}	Holding Time from Bit Clock High to Frame Sync	Short Frame Only	0			ns
t_{SFB}	Set-Up Time for Frame Sync to Bit Clock Low	Long Frame Only	80			ns
t_{DBD}	Delay Time from BCLK _X High to Data Valid	Load = 150 pF plus 2 LSTTL Loads	0		180	ns
t_{DBTS}	Delay Time to \overline{TS}_X Low	Load = 150 pF plus 2 LSTTL Loads			140	ns
t_{DZC}	Delay Time from BCLK _X Low to Data Output Disabled		50		165	ns
t_{DZF}	Delay Time to Valid Data from FS _X or BCLK _X , Whichever Comes Later	$C_L = 0$ pF to 150 pF	20		165	ns
t_{SDB}	Set-Up Time from D _R Valid to BCLK _{R/X} Low		50			ns
t_{HBD}	Hold Time from BCLK _{R/X} Low to D _R Invalid		50			ns
t_{SF}	Set-Up Time from FS _{X/R} to BCLK _{X/R} Low	Short Frame Sync Pulse (1 Bit Clock Period Long)	50			ns
t_{HF}	Hold Time from BCLK _{X/R} Low to FS _{X/R} Low	Short Frame Sync Pulse (1 Bit Clock Period Long)	100			ns
t_{HBF1}	Hold Time from 3rd Period of Bit Clock Low to Frame Sync (FS _X or FS _R)	Long Frame Sync Pulse (from 3 to 8 Bit Clock Periods Long)	100			ns
t_{WFL}	Minimum Width of the Frame Sync Pulse (Low Level)	64k Bit/s Operating Mode	160			ns
t_{SFFM}	Set-Up Time from FS _X High to MCLK _X Falling Edge	Long Frame Only	100			ns

Timing Diagrams

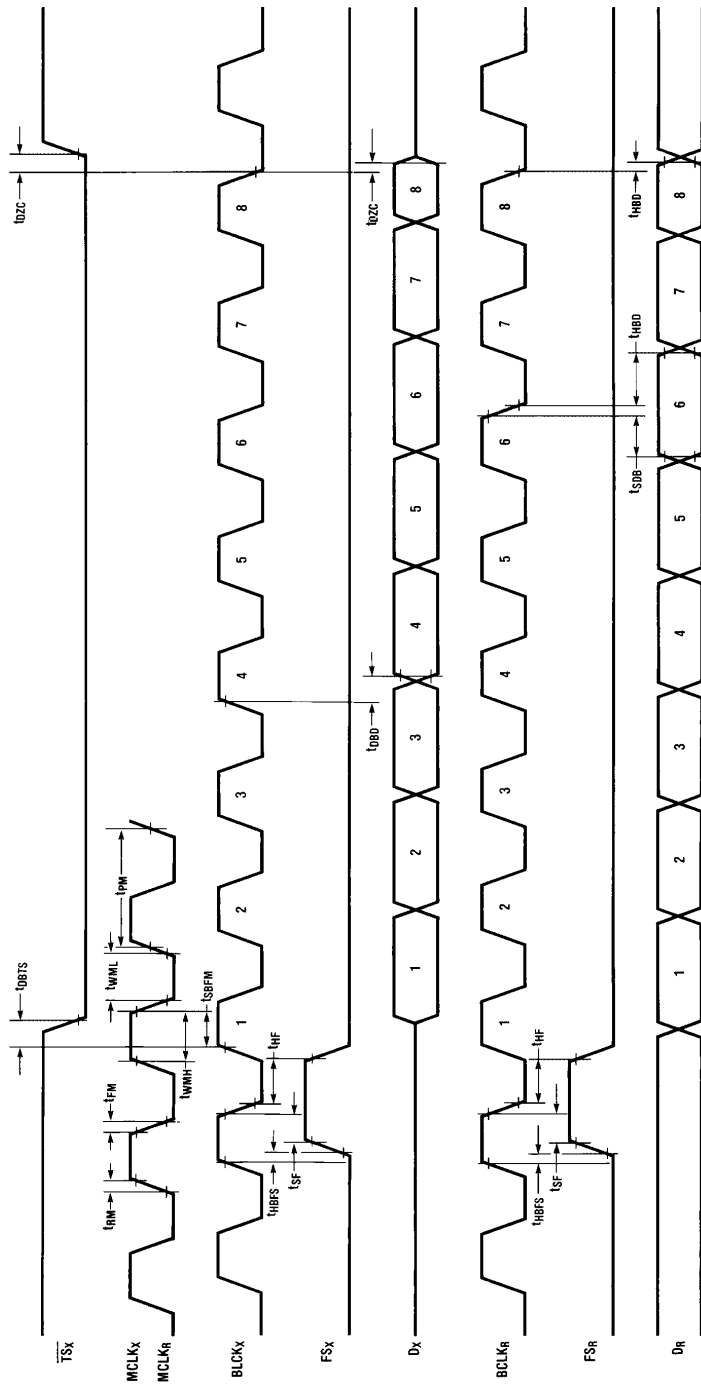

TL/H/10578-4

FIGURE 2. Short Frame Sync Timing

Timing Diagrams (Continued)

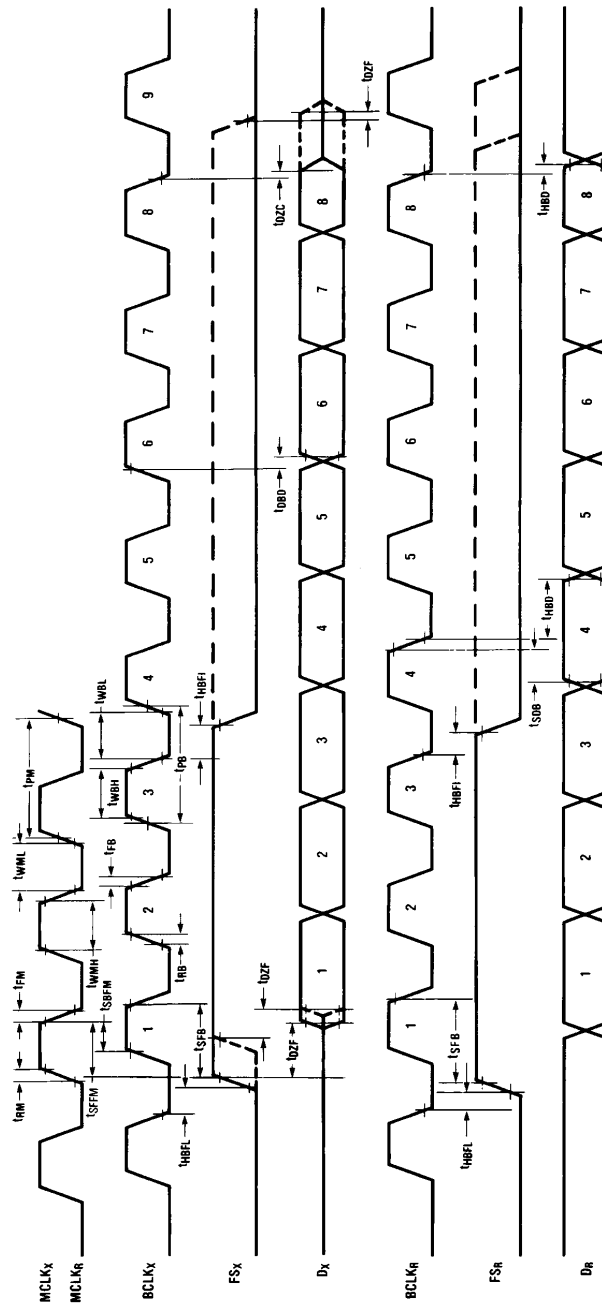

TL/H/10578-5

FIGURE 3. Long Frame Sync Timing

Transmission Characteristics

Unless otherwise noted, limits printed in **BOLD** characters are guaranteed for $V_{CC} = +5.0V \pm 5\%$, $V_{BB} = -5.0V \pm 5\%$; $T_A = 0^\circ\text{C}$ to 70°C by correlation with 100% electrical testing at $T_A = 25^\circ\text{C}$. All other limits are assured by correlation with other production tests and/or product design and characterization. $G_{NDA} = 0V$, $f = 1.02\text{ kHz}$, $V_{IN} = 0\text{ dbm0}$, transmit input amplifier connected for unity gain non-inverting. Typicals specified at $V_{CC} = +5.0V$, $V_{BB} = -5.0V$, $T_A = 25^\circ\text{C}$.

Symbol	Parameter	Conditions	Min	Typ	Max	Units
AMPLITUDE RESPONSE						
	Absolute Levels (Definition of nominal gain)	Nominal 0 dBm0 Level is 4 dBm (600Ω) 0 dBm0		1.2276		Vrms
t_{MAX}	Virtual Decision Value Defined per CCITT Rec. G711	Max Transmit Overload Level TP3069 (3.14 dBm0)		2.492		V_{PK}
G_{XA}	Transmit Gain, Absolute	$T_A = 25^\circ\text{C}$, $V_{CC} = 5V$, $V_{BB} = -5V$	-0.15		0.15	dB
G_{XR}	Transmit Gain, Relative to G_{XA}	f = 16 Hz f = 50 Hz f = 60 Hz f = 200 Hz f = 300 Hz-3000 Hz f = 3300 Hz f = 3400 Hz f = 4000 Hz f = 4600 Hz and Up, Measure Response from 0 Hz to 4000 Hz	-1.8 -0.15 -0.35 -0.7		-40 -30 -26 -0.1 0.15 0.05 0 -14 -32	dB dB dB dB dB dB dB dB dB
G_{XAT}	Absolute Transmit Gain Variation with Temperature	Relative to G_{XA}	-0.1		0.1	dB
G_{XAV}	Absolute Transmit Gain Variation with Supply Voltage	Relative to G_{XA}	-0.05		0.05	dB
G_{XRL}	Transmit Gain Variations with Level	Sinusoidal Test Method Reference Level = -10 dBm0 $V_{FXL}^+ = -40\text{ dBm0}$ to $+3\text{ dBm0}$ $V_{FXL}^+ = -50\text{ dBm0}$ to -40 dBm0 $V_{FXL}^+ = -55\text{ dBm0}$ to -50 dBm0	-0.2 -0.4 -1.2		0.2 0.4 1.2	dB dB dB
G_{RA}	Receive Gain, Absolute	$T_A = 25^\circ\text{C}$, $V_{CC} = 5V$, $V_{BB} = -5V$ Input = Digital Code Sequence for 0 dBm0 Signal	-0.15		0.15	dB
G_{RR}	Receive Gain, Relative to G_{RA}	f = 0 Hz to 3000 Hz f = 3300 Hz f = 3400 Hz f = 4000 Hz	-0.15 -0.35 -0.7		0.15 0.05 0 -14	dB dB dB dB
G_{RAT}	Absolute Receive Gain Variation with Temperature	Relative to G_{RA}	-0.1		0.1	dB
G_{RAV}	Absolute Receive Gain Variation with Supply Voltage	Relative to G_{RA}	-0.05		0.05	dB
G_{RRL}	Receive Gain Variations with Level	Sinusoidal Test Method; Reference Input PCM Code Corresponds to an Ideally Encoded -10 dBm0 Signal PCM Level = -40 dBm0 to +3 dBm0 PCM Level = -50 dBm0 to -40 dBm0 PCM Level = -55 dBm0 to -50 dBm0	-0.2 -0.4 -1.2		0.2 0.4 1.2	dB dB dB
V_{RO}	Receive Filter Output at V_{FRO}	$R_L = 10\text{ k}\Omega$	-2.5		2.5	V

Transmission Characteristics (Continued)

Unless otherwise noted, limits printed in **BOLD** characters are guaranteed for $V_{CC} = +5.0V \pm 5\%$, $V_{BB} = -5.0V \pm 5\%$; $T_A = 0^\circ\text{C}$ to 70°C by correlation with 100% electrical testing at $T_A = 25^\circ\text{C}$. All other limits are assured by correlation with other production tests and/or product design and characterization. $G_{ND A} = 0V$, $f = 1.02\text{ kHz}$, $V_{IN} = 0\text{ dBm0}$, transmit input amplifier connected for unity gain non-inverting. Typicals specified at $V_{CC} = +5.0V$, $V_{BB} = -5.0V$, $T_A = 25^\circ\text{C}$.

Symbol	Parameter	Conditions	Min	Typ	Max	Units
ENVELOPE DELAY DISTORTION WITH FREQUENCY						
D_{XA}	Transmit Delay, Absolute	$f = 1600\text{ Hz}$		290	315	μs
D_{XR}	Transmit Delay, Relative to D_{XA}	$f = 500\text{ Hz} - 600\text{ Hz}$		195	220	μs
		$f = 600\text{ Hz} - 800\text{ Hz}$		120	145	μs
		$f = 800\text{ Hz} - 1000\text{ Hz}$		50	75	μs
		$f = 1000\text{ Hz} - 1600\text{ Hz}$		20	40	μs
		$f = 1600\text{ Hz} - 2600\text{ Hz}$		55	75	μs
		$f = 2600\text{ Hz} - 2800\text{ Hz}$		80	105	μs
D_{RA}	Receive Delay, Absolute	$f = 1600\text{ Hz}$		180	200	μs
		$f = 2800\text{ Hz} - 3000\text{ Hz}$		130	155	μs
D_{RR}	Receive Delay, Relative to D_{RA}	$f = 500\text{ Hz} - 1000\text{ Hz}$	-40	-25		μs
		$f = 1000\text{ Hz} - 1600\text{ Hz}$	-30	-20		μs
		$f = 1600\text{ Hz} - 2600\text{ Hz}$		70	90	μs
		$f = 2600\text{ Hz} - 2800\text{ Hz}$		100	125	μs
		$f = 2800\text{ Hz} - 3000\text{ Hz}$		145	175	μs
NOISE						
N_{XP}	Transmit Noise, Psophometric Weighted	TP3069 (Note 1)		-74	-67	dBm0p
N_{RP}	Receive Noise, Psophometric Weighted	PCM Code Equals Positive Zero TP3069		-82	-79	dBm0p
N_{RS}	Noise, Single Frequency	$f = 0\text{ kHz}$ to 100 kHz , Loop Around Measurement, $V_{FX}^+ = 0\text{ Vrms}$			-53	dBm0
$PPSR_X$	Positive Power Supply Rejection, Transmit	$V_{CC} = 5.0\text{ V}_{DC} + 100\text{ mVrms}$ $f = 0\text{ kHz} - 50\text{ kHz}$ (Note 2)	40			dB
$NPSR_X$	Negative Power Supply Rejection, Transmit	$V_{BB} = -5.0\text{ V}_{DC} + 100\text{ mVrms}$ $f = 0\text{ kHz} - 50\text{ kHz}$ (Note 2)	40			dB
$PPSR_R$	Positive Power Supply Rejection, Receive	PCM Code Equals Positive Zero $V_{CC} = 5.0\text{ V}_{DC} + 100\text{ mVrms}$ Measure V_{FR0} $f = 0\text{ Hz} - 4000\text{ Hz}$	38			dB
		$f = 4\text{ kHz} - 50\text{ kHz}$	25			dB
$NPSR_R$	Negative Power Supply Rejection, Receive	PCM Code Equals Positive Zero $V_{BB} = -5.0\text{ V}_{DC} + 100\text{ mVrms}$ Measure V_{FR0} $f = 0\text{ Hz} - 4000\text{ Hz}$	40			dB
		$f = 4\text{ kHz} - 25\text{ kHz}$	40			dB
		$f = 25\text{ kHz} - 50\text{ kHz}$	36			dB
SOS	Spurious Out-of-Band Signals at the Channel Output	0 dBm0, 300 Hz - 3400 Hz Input PCM Code Applied at DR Measure Individual Image Signals at V_{FR0}				
		4600 Hz - 7600 Hz			-32	dB
		7600 Hz - 8400 Hz			-40	dB
		8400 Hz - 100,000 Hz			-32	dB

Transmission Characteristics (Continued)

Unless otherwise noted, limits printed in **BOLD** characters are guaranteed for $V_{CC} = +5.0V \pm 5\%$, $V_{BB} = -5.0V \pm 5\%$; $T_A = 0^\circ\text{C}$ to 70°C by correlation with 100% electrical testing at $T_A = 25^\circ\text{C}$. All other limits are assured by correlation with other production tests and/or product design and characterization. $G_{NDA} = 0V$, $f = 1.02\text{ kHz}$, $V_{IN} = 0\text{ dBm}_0$, transmit input amplifier connected for unity gain non-inverting. Typicals specified at $V_{CC} = +5.0V$, $V_{BB} = -5.0V$, $T_A = 25^\circ\text{C}$.

Symbol	Parameter	Conditions	Min	Typ	Max	Units
DISTORTION						
STD _X , STD _R	Signal to Total Distortion Transmit or Receive Half-Channel	Sinusoidal Test Method (Note 3) Level = 3.0 dBm ₀ = 0 dBm ₀ to -30 dBm ₀ = -40 dBm ₀ XMT RCV = -55 dBm ₀ XMT RCV	33 36 29 30 14 15			dBc dBc dBc dBc dBc dBc
SFD _X	Single Frequency Distortion, Transmit				-46	dB
SFD _R	Single Frequency Distortion, Receive				-46	dB
IMD	Intermodulation Distortion	Loop Around Measurement, $V_{FX1}^+ = -4\text{ dBm}_0$ to -21 dBm_0 , Two Frequencies in the Range 300 Hz - 3400 Hz			-41	dB
CROSSTALK						
CT _{X-R}	Transmit to Receive Crosstalk	$f = 300\text{ Hz} - 3000\text{ Hz}$ $D_R = \text{Quiet PCM Code}$		-90	-75	dB
CT _{R-X}	Receive to Transmit Crosstalk	$f = 300\text{ Hz} - 3000\text{ Hz}$, $V_{FX1} = 0V$ (Note 2)		-90	-70	dB
POWER AMPLIFIERS						
V _{OPA}	Maximum 0 dBm ₀ Level (Better than $\pm 0.1\text{ dB}$ Linearity over the Range -10 dBm_0 to $+3\text{ dBm}_0$)	Balanced Load, R_L Connected Between V_{PO}^+ and V_{PO}^- . $R_L = 600\Omega$ $R_L = 1200\Omega$	3.3 3.5			V _{rms} V _{rms}
S/D _P	Signal/Distortion	$R_L = 600\Omega$	50			dB

Note 1: Measured by extrapolation from the distortion test result at -50 dBm_0 .

Note 2: PPSR_X, NPSR_X, and CT_{R-X} are measured with a -50 dBm_0 activation signal applied to V_{FX1}^+ .

Note 3: TP3069 is measured using psophometric weighted filter.

Definitions and Timing Conventions

DEFINITIONS

V_{IH}	V_{IH} is the d.c. input level above which an input level is guaranteed to appear as a logical one. This parameter is to be measured by performing a functional test at reduced clock speeds and nominal timing, (i.e. not minimum setup and hold times or output strobes), with the high level of all driving signals set to V_{IH} and maximum supply voltages applied to the device
V_{IL}	V_{IL} is the d.c. input level below which an input level is guaranteed to appear as a logical zero to the device. This parameter is measured in the same manner as V_{IH} but with all driving signal low levels set to V_{IL} and minimum supply voltages applied to the device.
V_{OH}	V_{OH} is the minimum d.c. output level to which an output placed in a logical one state will converge when loaded at the maximum specified load current.
V_{OL}	V_{OL} is the maximum d.c. output level to which an output placed in a logical zero state will converge when loaded at the maximum specified load current.
Threshold Region	The threshold region is the range of input voltages between V_{IL} and V_{IH} .
Valid Signal	A signal is Valid if it is in one of the valid logic states, (i.e. above V_{IH} or below V_{IL}). In timing specifications, a signal is deemed valid at the instant it enters a valid state.
Invalid Signal	A signal is Invalid if it is not in a valid logic state, i.e. when it is in the threshold region between V_{IL} and V_{IH} . In timing specifications, a signal is deemed Invalid at the instant it enters the threshold region.

TIMING CONVENTIONS

For the purposes of this timing specification, the following conventions apply:

Input Signals	All input signals may be characterized as: $V_L = 0.4V$, $V_H = 2.4V$, $t_R < 10$ ns, $t_F < 10$ ns.
Period	The period of clock signal is designated as t_{Pxx} where xx represents the mnemonic of the clock signal being specified.
Rise Time	Rise times are designated as t_{Ryy} , where yy represents a mnemonic of the signal whose rise time is being specified. t_{Ryy} is measured from V_{IL} to V_{IH} .
Fall Time	Fall times are designated as t_{Fyy} , where yy represents a mnemonic of the signal whose fall time is being specified. t_{Fyy} is measured from V_{IH} to V_{IL} .
Pulse Width High	The high pulse width is designated as t_{WzzH} , where zz represents the mnemonic of the input or output signal whose pulse width is being specified. High pulse widths are measured from V_{IH} to V_{IH} .
Pulse Width Low	The low pulse width is designated as t_{WzzL} , where zz represents the mnemonic of the input or output signal whose pulse width is being specified. Low pulse widths are measured from V_{IL} to V_{IL} .
Setup Time	Setup times are designated as t_{Swwxx} , where ww represents the mnemonic of the input signal whose setup time is being specified relative to a clock or strobe input represented by mnemonic xx. Setup times are measured from the ww Valid to xx Invalid.
Hold Time	Hold times are designated as t_{Hxxww} , where ww represents the mnemonic of the input signal whose hold time is being specified relative to a clock or strobe input represented by mnemonic xx. Hold times are measured from xx Valid to ww Invalid.
Delay Time	Delay times are designated as t_{Dxxyy} Hi to Low, where xx represents the mnemonic of the input reference signal and yy represents the mnemonic of the output signal whose timing is being specified relative to xx. The mnemonic may optionally be terminated by an H or L to specify the high going or low going transition of the output signal. Maximum delay times are measured from xx Valid to yy Valid. Minimum delay times are measured from xx Valid to yy Invalid. This parameter is tested under the load conditions specified in the Conditions column of the Timing Specifications section of this data sheet.

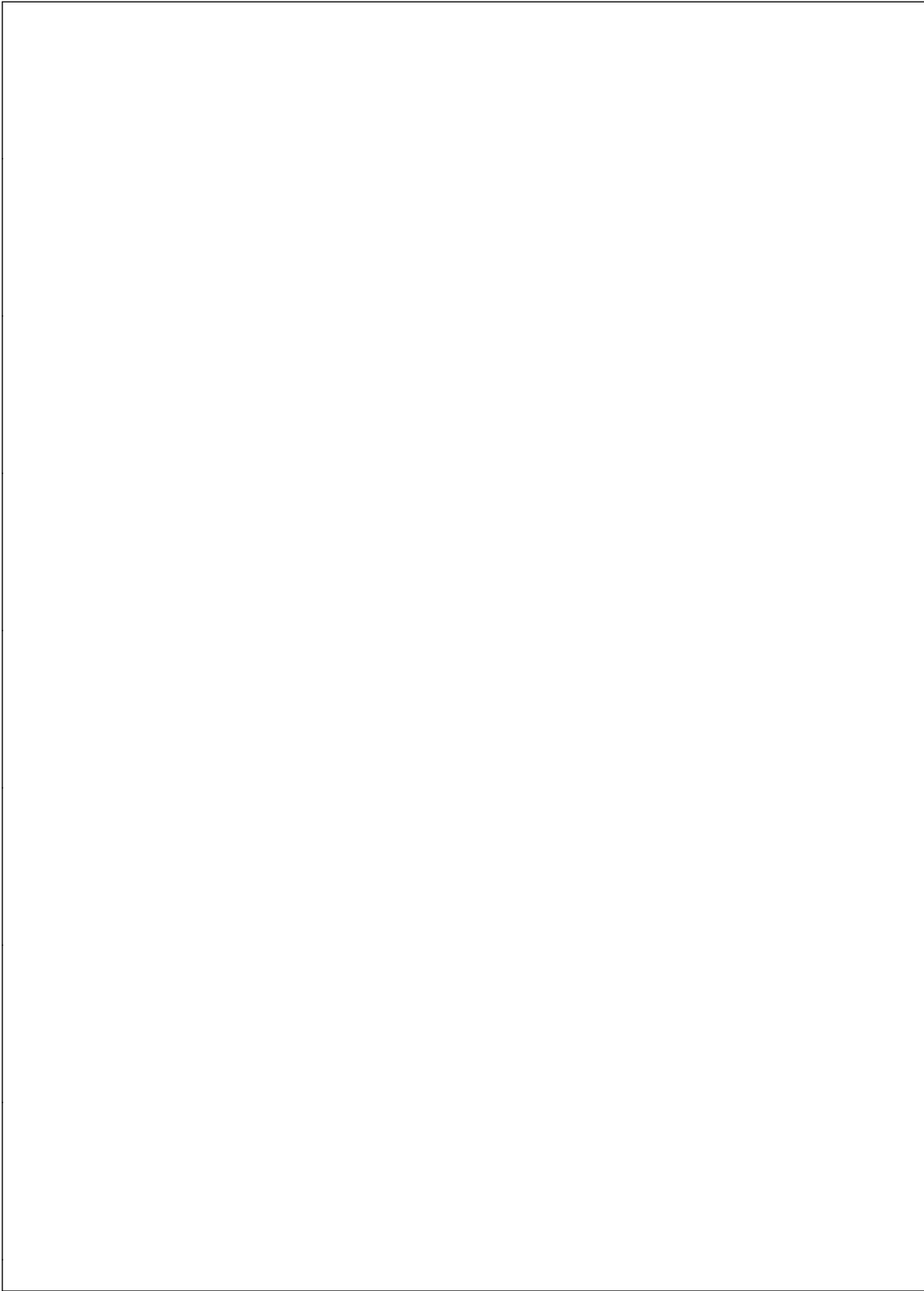

Physical Dimensions inches (millimeters)

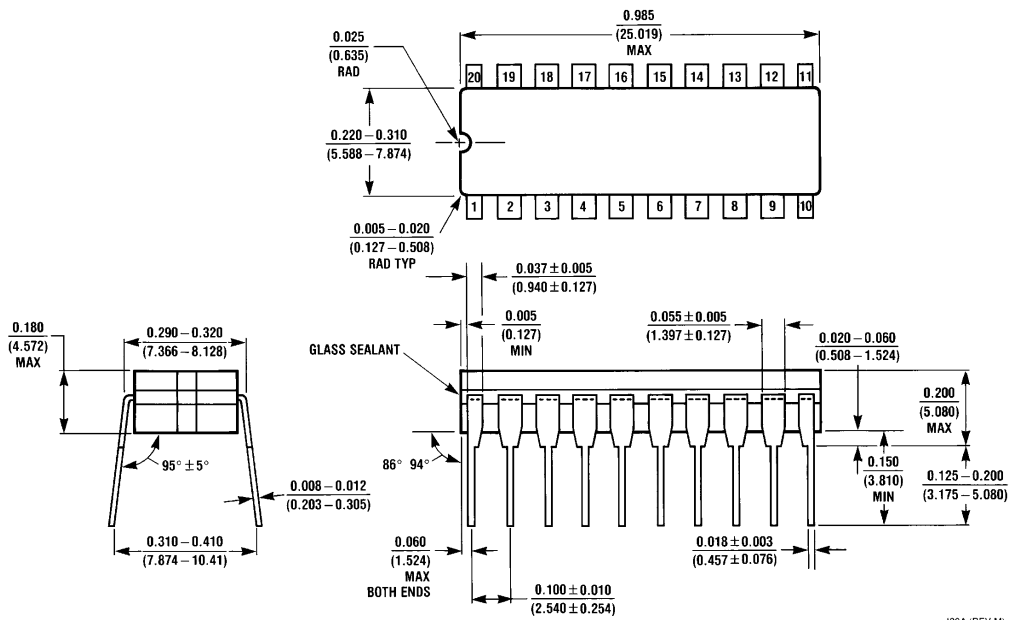

Cavity Dual-In-Line Package (J)
Order Number TP3069J
NS Package Number J20A

J20A (REV M)

Physical Dimensions inches (millimeters) (Continued)

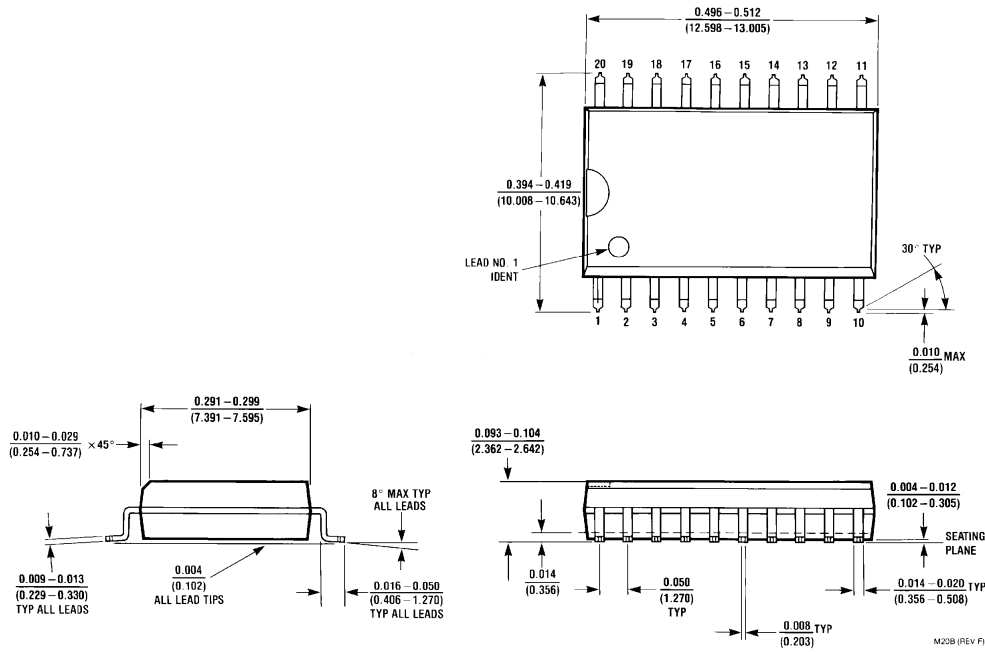

**20 Lead (0.300" Wide)
Molded Small Outline Package (WM)
Order Number TP3069WM
NS Package Number M20B**

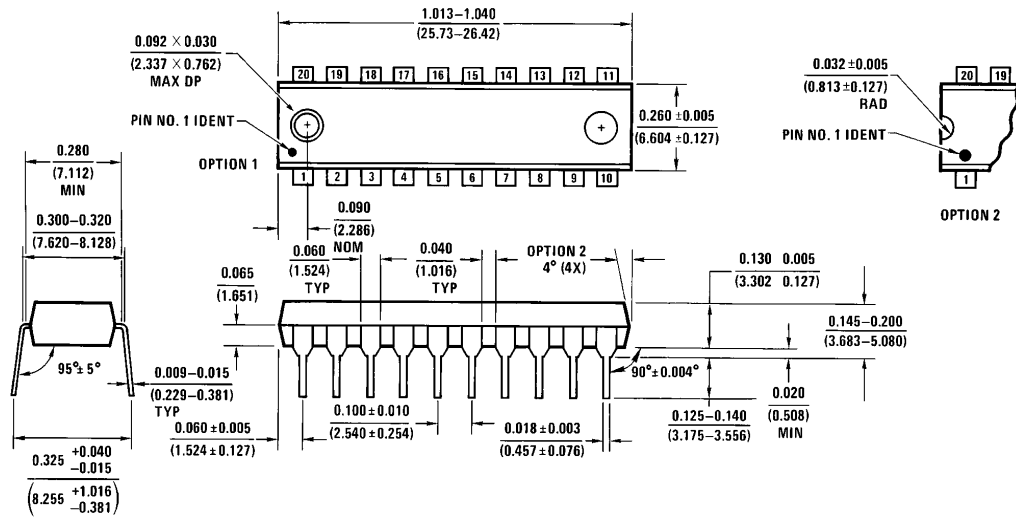

**Molded Dual-In-Line Package (N)
Order Number TP3069N
NS Package Number N20A**

Physical Dimensions inches (millimeters) (Continued)

Lit. # 113976

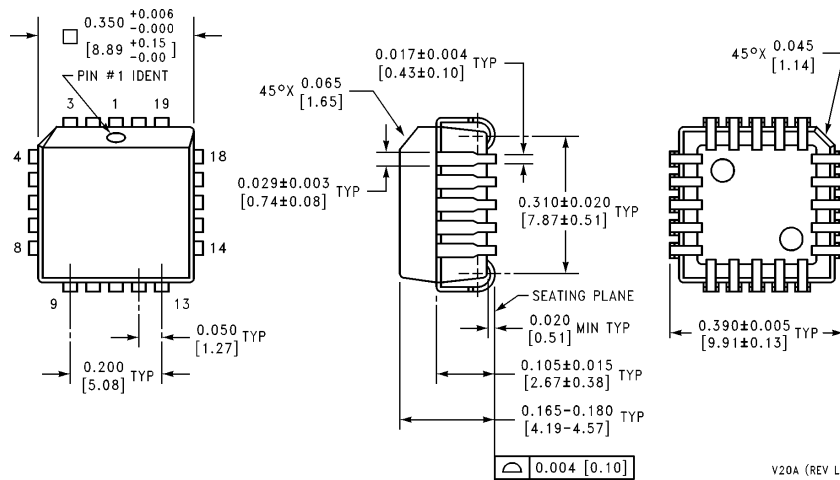

**Plastic Chip Carrier (V)
Order Number TP3069V
NS Package Number V20A**

V20A (REV L)

LIFE SUPPORT POLICY

NATIONAL'S PRODUCTS ARE NOT AUTHORIZED FOR USE AS CRITICAL COMPONENTS IN LIFE SUPPORT DEVICES OR SYSTEMS WITHOUT THE EXPRESS WRITTEN APPROVAL OF THE PRESIDENT OF NATIONAL SEMICONDUCTOR CORPORATION. As used herein:

1. Life support devices or systems are devices or systems which, (a) are intended for surgical implant into the body, or (b) support or sustain life, and whose failure to perform, when properly used in accordance with instructions for use provided in the labeling, can be reasonably expected to result in a significant injury to the user.
2. A critical component is any component of a life support device or system whose failure to perform can be reasonably expected to cause the failure of the life support device or system, or to affect its safety or effectiveness.



National Semiconductor Corporation
1111 West Bardin Road
Arlington, TX 76017
Tel: 1(800) 272-9959
Fax: 1(800) 737-7018

National Semiconductor Europe
Fax: (+49) 0-180-530 85 86
Email: cnjwge@tevm2.nsc.com
Deutsch Tel: (+49) 0-180-530 85 85
English Tel: (+49) 0-180-532 78 32
Français Tel: (+49) 0-180-532 93 58
Italiano Tel: (+49) 0-180-534 16 80

National Semiconductor Hong Kong Ltd.
19th Floor, Straight Block,
Ocean Centre, 5 Canton Rd.
Tsimshatsui, Kowloon
Hong Kong
Tel: (852) 2737-1600
Fax: (852) 2736-9960

National Semiconductor Japan Ltd.
Tel: 81-043-299-2309
Fax: 81-043-299-2408

National does not assume any responsibility for use of any circuitry described, no circuit patent licenses are implied and National reserves the right at any time without notice to change said circuitry and specifications.

This datasheet has been download from:

www.datasheetcatalog.com

Datasheets for electronics components.