

TL2218-285, TL2218-285Y EXCALIBUR CURRENT-MODE SCSI TERMINATOR

SLVS072C – DECEMBER 1992 – REVISED OCTOBER 1995

available features

- Fully Integrated 9-Channel SCSI Termination
- No External Components Required
- Maximum Allowed Current Applied at First High-Level Step
- 6-pF Typical Power-Down Output Capacitance
- Wide $V_{\text{term}}^{\dagger}$ (Termination Voltage) Operating Range, 3.5 V to 5.5 V
- TTL-Compatible Disable Feature
- Compatible With Active Negation
- Thermal Regulation

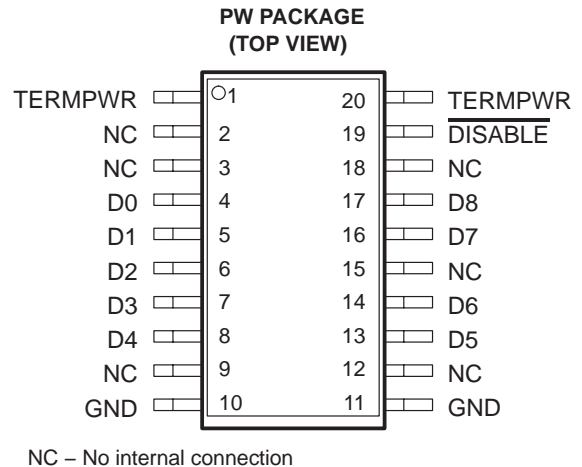

description

The TL2218-285 is a current-mode 9-channel monolithic terminator specially designed for single-ended small-computer-systems-interface (SCSI) bus termination. A user-controlled disable function is provided to reduce standby power. No impedance-matching resistors or other external components are required for its operation as a complete terminator.

The device operates over a wide termination-voltage ($V_{\text{term}}^{\dagger}$) range of 3.5 V to 5.5 V, offering an extra 0.5 V of operating range when compared to the minimum termination voltage of 4 V required by other integrated active terminators. The TL2218-285 functions as a current-sourcing terminator and supplies a constant output current of 23 mA into each asserted line. When a line is deasserted, the device senses the rising voltage level and begins to function as a voltage source, supplying a fixed output voltage of 2.85 V. The TL2218-285 features compatibility with active negation drivers and has a typical sink current capability of 20 mA.

The TL2218-285 is able to ensure that maximum current is applied at the first high-level step. This performance means that the device should provide a first high-level step exceeding 2 V even at a 10-MHz rate. Therefore, noise margins are improved considerably above those provided by resistive terminators.

A key difference between the TL2218-285 current-mode terminator and a Boulay terminator is that the TL2218-285 does not incorporate a low dropout regulator to set the output voltage to 2.85 V. In contrast with the Boulay termination concept, the accuracy of the 2.85 V is not critical with the current-mode method used in the TL2218-285 because this voltage does not determine the driver current. Therefore, the primary device specifications are not the same as with a voltage regulator but are more concerned with output current.

The DISABLE terminal is TTL compatible and must be taken low to shut down the outputs. The device is normally active, even when DISABLE is left floating. In the disable mode, only the device startup circuits remain active, thereby reducing the supply current to just 500 μA . Output capacitance in the shutdown mode is typically 6 pF.

The TL2218-285 has on-board thermal regulation and current limiting, thus eliminating the need for external protection circuitry. A thermal regulation circuit that is designed to provide current limiting, rather than an actual thermal shutdown, is included in the individual channels of the TL2218-285. When a system fault occurs that leads to excessive power dissipation by the terminator, the thermal regulation circuit causes a reduction in the asserted-line output current sufficient to maintain operation. This feature allows the bus to remain active during a fault condition, which permits data transfer immediately upon removal of the fault. A terminator with thermal shutdown does not allow for data transfer until sufficient cooling has occurred. Another advantage offered by the TL2218-285 is a design that does not require costly laser trimming in the manufacturing process.

The TL2218-285 is characterized for operation over the virtual junction temperature range of 0°C to 125°C.

[†] This symbol is not presently listed within EIA/JEDEC standards for letter symbols.

TL2218-285, TL2218-285Y EXCALIBUR CURRENT-MODE SCSI TERMINATOR

SLVS072C – DECEMBER 1992 – REVISED OCTOBER 1995

AVAILABLE OPTIONS

T _J	SURFACE MOUNT (PW) [†]	CHIP FORM (Y)
0°C to 125°C	TL2218-285PWLE	TL2218-285Y

[†] The PW package is only available left-end taped and reeled.

TL2218-285Y chip information

This chip, when properly assembled, displays characteristics similar to the TL2218-285. Thermal compression or ultrasonic bonding may be used on the doped aluminum bonding pads. The chip may be mounted with conductive epoxy or a gold-silicon preform.

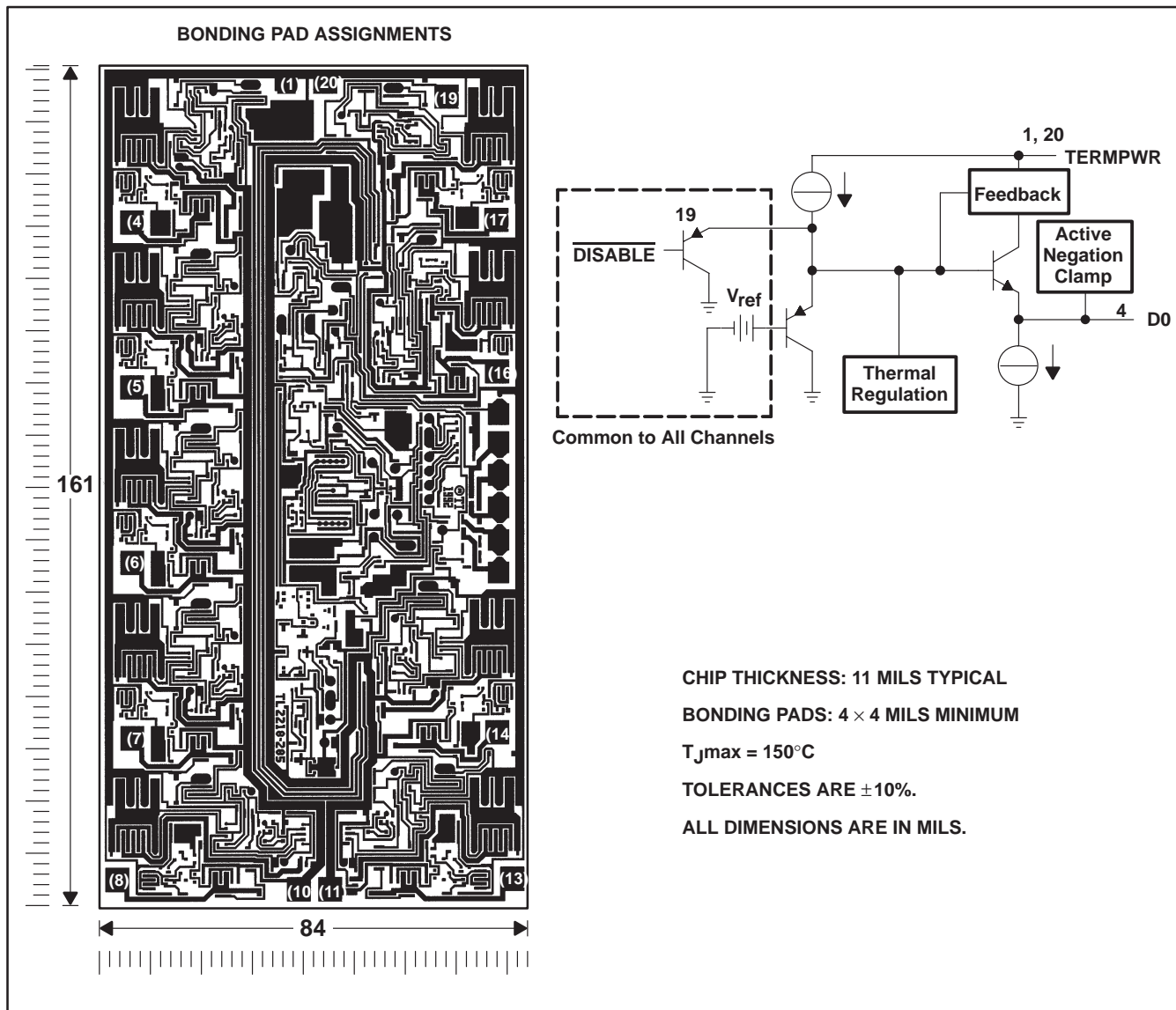

TL2218-285, TL2218-285Y EXCALIBUR CURRENT-MODE SCSI TERMINATOR

SLVS072C – DECEMBER 1992 – REVISED OCTOBER 1995

functional block diagram (each channel)

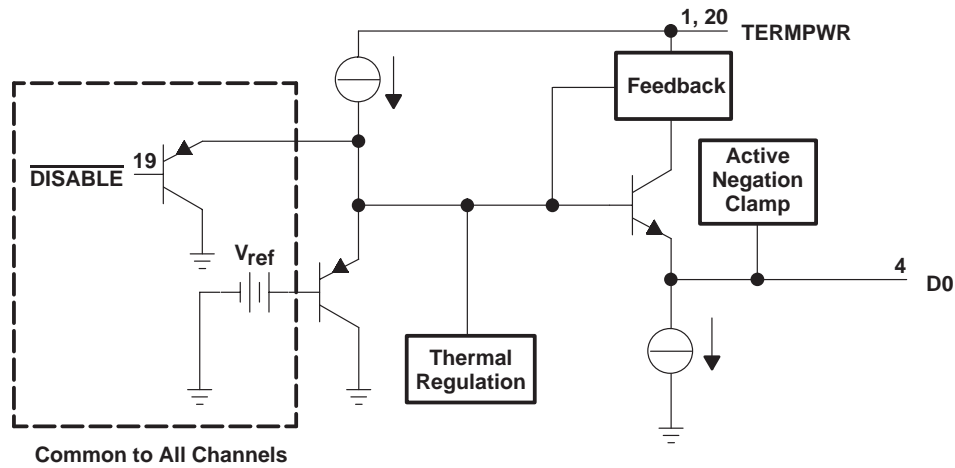

absolute maximum ratings over operating free-air temperature range (unless otherwise noted) (see Figures 1, 2, and 3)[†]

Continuous termination voltage	10 V
Continuous output voltage range	0 V to 5.5 V
Continuous disable voltage range	0 V to 5.5 V
Continuous total power dissipation	See Dissipation Rating Table
Operating virtual junction temperature range, T_J	-55°C to 150°C
Storage temperature range, T_{stg}	-60°C to 150°C
Lead temperature 1,6 mm (1/16 inch) from case for 10 seconds	260°C

[†] Stresses beyond those listed under "absolute maximum ratings" may cause permanent damage to the device. These are stress ratings only, and functional operation of the device at these or any other conditions beyond those indicated under "recommended operating conditions" is not implied. Exposure to absolute-maximum-rated conditions for extended periods may affect device reliability.

DISSIPATION RATING TABLE

PACKAGE	POWER RATING AT	$T \leq 25^\circ\text{C}$	DERATING FACTOR	$T = 70^\circ\text{C}$	$T = 85^\circ\text{C}$	$T = 125^\circ\text{C}$
		POWER RATING	ABOVE $T = 25^\circ\text{C}$	POWER RATING	POWER RATING	POWER RATING
PW	T_A	828 mW	6.62 mW/°C	530 mW	430 mW	166 mW
	T_C	4032 mW	32.2 mW/°C	2583 mW	2100 mW	812 mW
	T_L [‡]	2475 mW	19.8 mW/°C	1584 mW	1287 mW	495 mW

[‡] $R_{\theta JL}$ is the thermal resistance between the junction and device lead. To determine the virtual junction temperature (T_J) relative to the device lead temperature, the following calculations should be used: $T_J = P_D \times R_{\theta JL} + T_L$, where P_D is the internal power dissipation of the device and T_L is the device lead temperature at the point of contact to the printed wiring board. $R_{\theta JL}$ is 50.5°C/W.

TL2218-285, TL2218-285Y EXCALIBUR CURRENT-MODE SCSI TERMINATOR

SLVS072C – DECEMBER 1992 – REVISED OCTOBER 1995

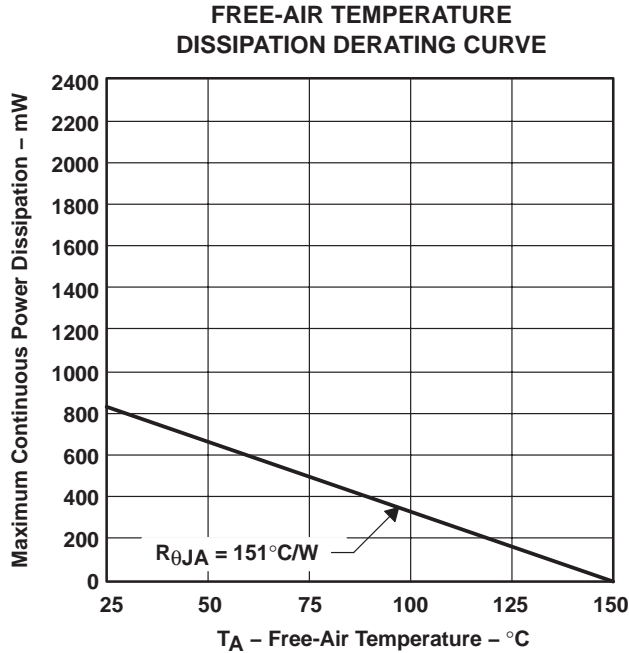

Figure 1

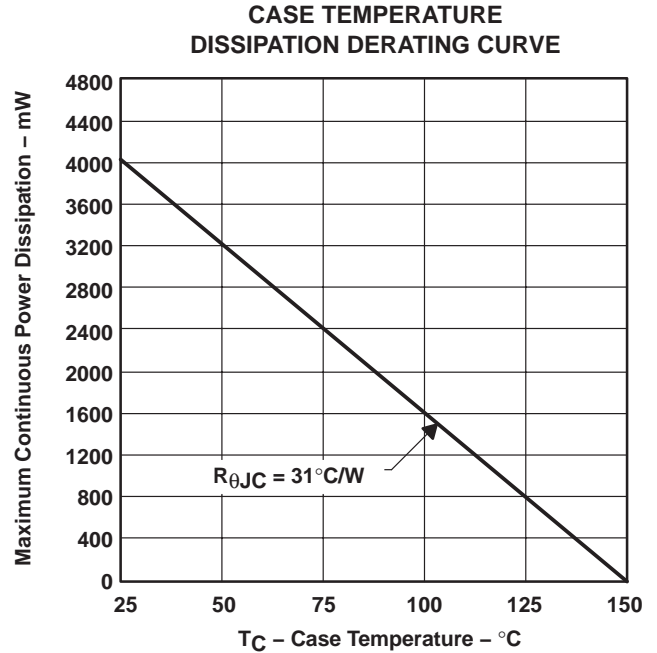

Figure 2

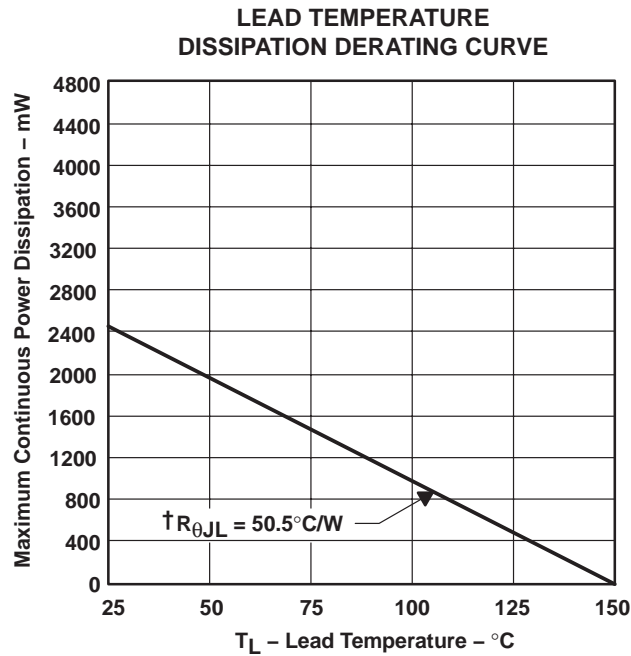

Figure 3

† $R_{\theta JL}$ is the thermal resistance between the junction and device lead. To determine the virtual junction temperature (T_J) relative to the device lead temperature, the following calculations should be used: $T_J = P_D \times R_{\theta JL} + T_L$, where P_D is the internal power dissipation of the device, and T_L is the device lead temperature at the point of contact to the printed wiring board. $R_{\theta JL}$ is 50.5°C/W.

TL2218-285, TL2218-285Y EXCALIBUR CURRENT-MODE SCSI TERMINATOR

SLVS072C – DECEMBER 1992 – REVISED OCTOBER 1995

recommended operating conditions

	MIN	MAX	UNIT
Termination voltage	3.5	5.5	V
High-level disable input voltage, V_{IH}	2	V_{term}	V
Low-level disable input voltage, V_{IL}	0	0.8	V
Operating virtual junction temperature, T_J	0	125	°C

electrical characteristics, $V_{term} = 4.75\text{ V}$, $V_O = 0.5\text{ V}$, $T_J = 25^\circ\text{C}$

PARAMETER	TEST CONDITIONS	MIN	TYP	MAX	UNIT
Output high voltage		2.5	2.85		V
TERMPWR supply current	All data lines open		9		mA
	All data lines = 0.5 V		228		
	$\overline{\text{DISABLE}} = 0\text{ V}$		500		μA
Output current		-20.5	-23	-24	mA
Disable input current (see Note 1)	$\overline{\text{DISABLE}} = 4.75\text{ V}$			1	μA
	$\overline{\text{DISABLE}} = 0\text{ V}$			600	
Output leakage current	$\overline{\text{DISABLE}} = 0\text{ V}$		100		nA
Output capacitance, device disabled	$V_O = 0\text{ V}$, 1 MHz		6		pF
Termination sink current, total	$V_O = 4\text{ V}$		20		mA

NOTE 1: When $\overline{\text{DISABLE}}$ is open or high, the terminator is active.



TL2218-285, TL2218-285Y EXCALIBUR CURRENT-MODE SCSI TERMINATOR

SLVS072C – DECEMBER 1992 – REVISED OCTOBER 1995

THERMAL INFORMATION

The need for smaller surface-mount packages for use on compact printed-wiring boards (PWB) causes an increasingly difficult problem in the area of thermal dissipation. In order to provide the systems designer with a better approximation of the junction temperature rise in the thin-shrink small-outline package (TSSOP), the junction-to-lead thermal resistance ($R_{\theta JL}$) is provided along with the more typical values of junction-to-ambient and junction-to-case thermal resistances, $R_{\theta JA}$ and $R_{\theta JC}$.

$R_{\theta JL}$ is used to calculate the device junction temperature rise measured from the leads of the unit. Consequently, the junction temperature is dependent upon the board temperature at the leads, $R_{\theta JL}$, and the internal power dissipation of the device. The board temperature is contingent upon several variables, including device packing density, thickness, material, area, and number of interconnects. The $R_{\theta JL}$ value depends on the number of leads connecting to the die-mount pad, the lead-frame alloy, area of the die, mount material, and mold compound. Since the power level at which the TSSOP can be used is highly dependent upon both the temperature rise of the PWB and the device itself, the systems designer can maximize this level by optimizing the circuit board. The junction temperature of the device can be calculated using the equation $T_J = (P_D \times R_{\theta JL}) + T_L$ where T_J = junction temperature, P_D = power dissipation, $R_{\theta JL}$ = junction-to-lead thermal resistance, and T_L = board temperature at the leads of the unit.

The values of thermal resistance for the TL2218-285 PW are as follows:

Thermal Resistance	Typical Junction Rise
$R_{\theta JA}$	151°C/W
$R_{\theta JC}$	31 °C/W
$R_{\theta JL}$	50.5°C/W

TYPICAL CHARACTERISTICS

Table of Graphs

			FIGURE
I_O	Output current	vs Input voltage	4
V_O	Output voltage	vs Input voltage	5
I_O	Output current	vs Junction temperature	6
V_O	Output voltage	vs Junction temperature	7

TYPICAL CHARACTERISTICS

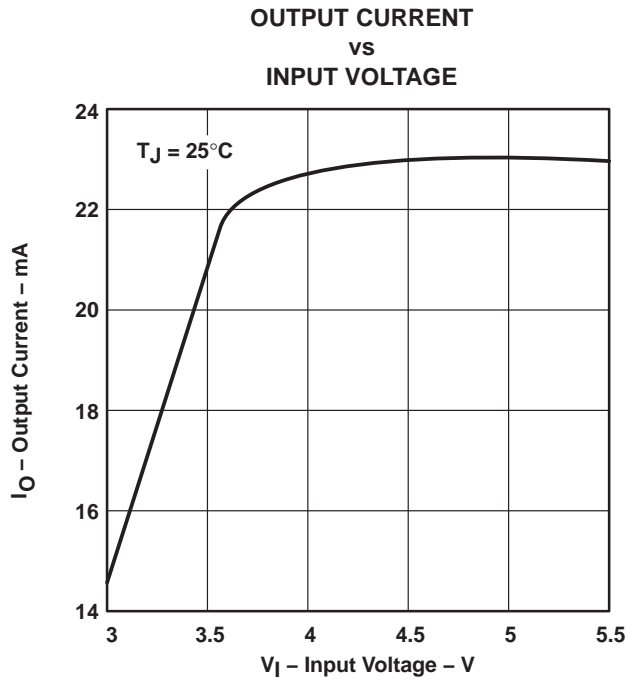

Figure 4

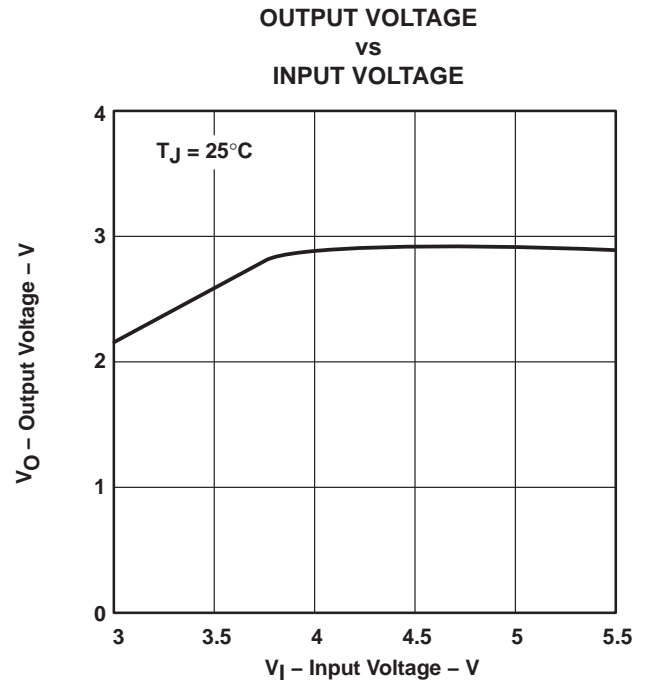

Figure 5

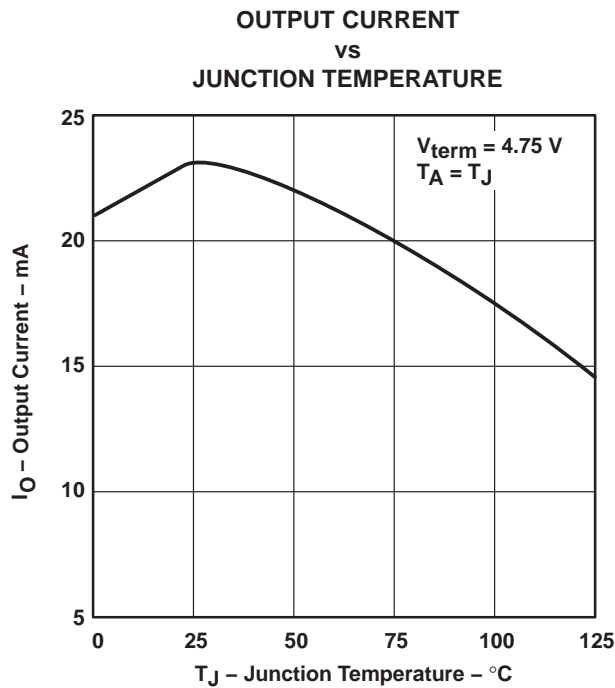

Figure 6

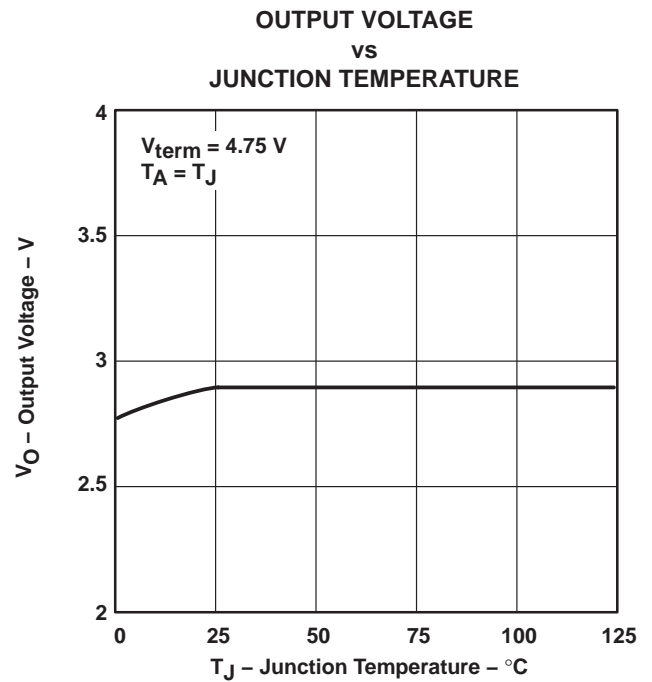

Figure 7

PACKAGING INFORMATION

Orderable Device	Status ⁽¹⁾	Package Type	Package Drawing	Pins	Package Qty	Eco Plan ⁽²⁾	Lead/Ball Finish	MSL Peak Temp ⁽³⁾
TL2218-285PW	ACTIVE	TSSOP	PW	20	70	Green (RoHS & no Sb/Br)	CU NIPDAU	Level-1-260C-UNLIM
TL2218-285PWG4	ACTIVE	TSSOP	PW	20	70	Green (RoHS & no Sb/Br)	CU NIPDAU	Level-1-260C-UNLIM
TL2218-285PWLE	OBSOLETE	TSSOP	PW	20		TBD	Call TI	Call TI
TL2218-285PWR	ACTIVE	TSSOP	PW	20	2000	Green (RoHS & no Sb/Br)	CU NIPDAU	Level-1-260C-UNLIM
TL2218-285PWRG4	ACTIVE	TSSOP	PW	20	2000	Green (RoHS & no Sb/Br)	CU NIPDAU	Level-1-260C-UNLIM

⁽¹⁾ The marketing status values are defined as follows:

ACTIVE: Product device recommended for new designs.

LIFEBUY: TI has announced that the device will be discontinued, and a lifetime-buy period is in effect.

NRND: Not recommended for new designs. Device is in production to support existing customers, but TI does not recommend using this part in a new design.

PREVIEW: Device has been announced but is not in production. Samples may or may not be available.

OBSOLETE: TI has discontinued the production of the device.

⁽²⁾ Eco Plan - The planned eco-friendly classification: Pb-Free (RoHS), Pb-Free (RoHS Exempt), or Green (RoHS & no Sb/Br) - please check <http://www.ti.com/productcontent> for the latest availability information and additional product content details.

TBD: The Pb-Free/Green conversion plan has not been defined.

Pb-Free (RoHS): TI's terms "Lead-Free" or "Pb-Free" mean semiconductor products that are compatible with the current RoHS requirements for all 6 substances, including the requirement that lead not exceed 0.1% by weight in homogeneous materials. Where designed to be soldered at high temperatures, TI Pb-Free products are suitable for use in specified lead-free processes.

Pb-Free (RoHS Exempt): This component has a RoHS exemption for either 1) lead-based flip-chip solder bumps used between the die and package, or 2) lead-based die adhesive used between the die and leadframe. The component is otherwise considered Pb-Free (RoHS compatible) as defined above.

Green (RoHS & no Sb/Br): TI defines "Green" to mean Pb-Free (RoHS compatible), and free of Bromine (Br) and Antimony (Sb) based flame retardants (Br or Sb do not exceed 0.1% by weight in homogeneous material)

⁽³⁾ MSL, Peak Temp. -- The Moisture Sensitivity Level rating according to the JEDEC industry standard classifications, and peak solder temperature.

Important Information and Disclaimer:The information provided on this page represents TI's knowledge and belief as of the date that it is provided. TI bases its knowledge and belief on information provided by third parties, and makes no representation or warranty as to the accuracy of such information. Efforts are underway to better integrate information from third parties. TI has taken and continues to take reasonable steps to provide representative and accurate information but may not have conducted destructive testing or chemical analysis on incoming materials and chemicals. TI and TI suppliers consider certain information to be proprietary, and thus CAS numbers and other limited information may not be available for release.

In no event shall TI's liability arising out of such information exceed the total purchase price of the TI part(s) at issue in this document sold by TI to Customer on an annual basis.

TAPE AND REEL INFORMATION

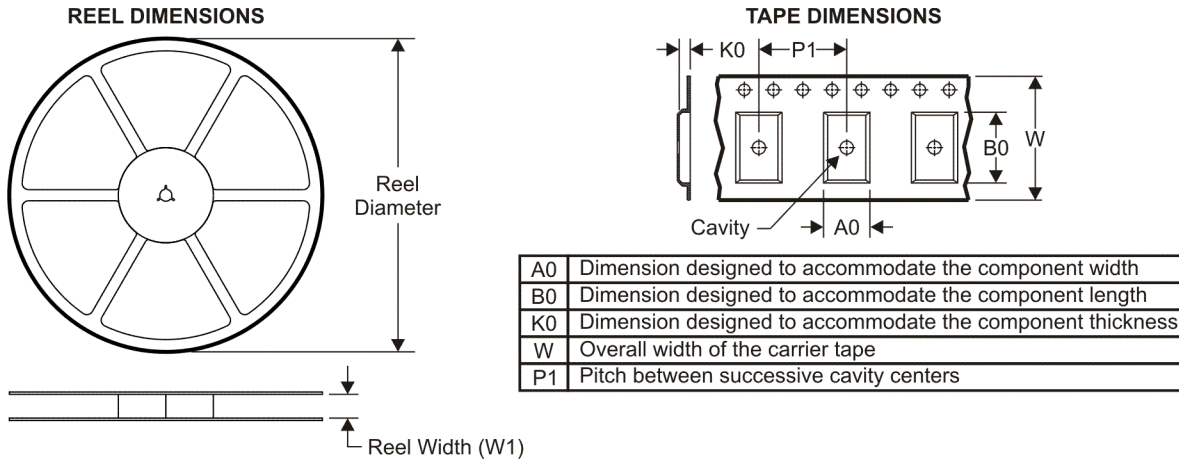

QUADRANT ASSIGNMENTS FOR PIN 1 ORIENTATION IN TAPE

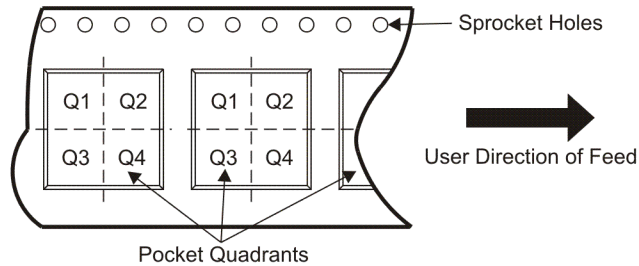

*All dimensions are nominal

Device	Package Type	Package Drawing	Pins	SPQ	Reel Diameter (mm)	Reel Width W1 (mm)	A0 (mm)	B0 (mm)	K0 (mm)	P1 (mm)	W (mm)	Pin1 Quadrant
TL2218-285PWR	TSSOP	PW	20	2000	330.0	16.4	6.95	7.1	1.6	8.0	16.0	Q1

TAPE AND REEL BOX DIMENSIONS



*All dimensions are nominal

Device	Package Type	Package Drawing	Pins	SPQ	Length (mm)	Width (mm)	Height (mm)
TL2218-285PWR	TSSOP	PW	20	2000	346.0	346.0	33.0

IMPORTANT NOTICE

Texas Instruments Incorporated and its subsidiaries (TI) reserve the right to make corrections, modifications, enhancements, improvements, and other changes to its products and services at any time and to discontinue any product or service without notice. Customers should obtain the latest relevant information before placing orders and should verify that such information is current and complete. All products are sold subject to TI's terms and conditions of sale supplied at the time of order acknowledgment.

TI warrants performance of its hardware products to the specifications applicable at the time of sale in accordance with TI's standard warranty. Testing and other quality control techniques are used to the extent TI deems necessary to support this warranty. Except where mandated by government requirements, testing of all parameters of each product is not necessarily performed.

TI assumes no liability for applications assistance or customer product design. Customers are responsible for their products and applications using TI components. To minimize the risks associated with customer products and applications, customers should provide adequate design and operating safeguards.

TI does not warrant or represent that any license, either express or implied, is granted under any TI patent right, copyright, mask work right, or other TI intellectual property right relating to any combination, machine, or process in which TI products or services are used. Information published by TI regarding third-party products or services does not constitute a license from TI to use such products or services or a warranty or endorsement thereof. Use of such information may require a license from a third party under the patents or other intellectual property of the third party, or a license from TI under the patents or other intellectual property of TI.

Reproduction of TI information in TI data books or data sheets is permissible only if reproduction is without alteration and is accompanied by all associated warranties, conditions, limitations, and notices. Reproduction of this information with alteration is an unfair and deceptive business practice. TI is not responsible or liable for such altered documentation. Information of third parties may be subject to additional restrictions.

Resale of TI products or services with statements different from or beyond the parameters stated by TI for that product or service voids all express and any implied warranties for the associated TI product or service and is an unfair and deceptive business practice. TI is not responsible or liable for any such statements.

TI products are not authorized for use in safety-critical applications (such as life support) where a failure of the TI product would reasonably be expected to cause severe personal injury or death, unless officers of the parties have executed an agreement specifically governing such use. Buyers represent that they have all necessary expertise in the safety and regulatory ramifications of their applications, and acknowledge and agree that they are solely responsible for all legal, regulatory and safety-related requirements concerning their products and any use of TI products in such safety-critical applications, notwithstanding any applications-related information or support that may be provided by TI. Further, Buyers must fully indemnify TI and its representatives against any damages arising out of the use of TI products in such safety-critical applications.

TI products are neither designed nor intended for use in military/aerospace applications or environments unless the TI products are specifically designated by TI as military-grade or "enhanced plastic." Only products designated by TI as military-grade meet military specifications. Buyers acknowledge and agree that any such use of TI products which TI has not designated as military-grade is solely at the Buyer's risk, and that they are solely responsible for compliance with all legal and regulatory requirements in connection with such use.

TI products are neither designed nor intended for use in automotive applications or environments unless the specific TI products are designated by TI as compliant with ISO/TS 16949 requirements. Buyers acknowledge and agree that, if they use any non-designated products in automotive applications, TI will not be responsible for any failure to meet such requirements.

Following are URLs where you can obtain information on other Texas Instruments products and application solutions:

Products

Audio	www.ti.com/audio
Amplifiers	amplifier.ti.com
Data Converters	dataconverter.ti.com
DLP® Products	www.dlp.com
DSP	dsp.ti.com
Clocks and Timers	www.ti.com/clocks
Interface	interface.ti.com
Logic	logic.ti.com
Power Mgmt	power.ti.com
Microcontrollers	microcontroller.ti.com
RFID	www.ti-rfid.com
RF/IF and ZigBee® Solutions	www.ti.com/lprf

Applications

Communications and Telecom	www.ti.com/communications
Computers and Peripherals	www.ti.com/computers
Consumer Electronics	www.ti.com/consumer-apps
Energy and Lighting	www.ti.com/energy
Industrial	www.ti.com/industrial
Medical	www.ti.com/medical
Security	www.ti.com/security
Space, Avionics and Defense	www.ti.com/space-avionics-defense
Transportation and Automotive	www.ti.com/automotive
Video and Imaging	www.ti.com/video
Wireless	www.ti.com/wireless-apps

TI E2E Community Home Page

e2e.ti.com

Mailing Address: Texas Instruments, Post Office Box 655303, Dallas, Texas 75265
Copyright © 2011, Texas Instruments Incorporated