

DATA SHEET

TEA6320

Sound fader control circuit

Preliminary specification
Supersedes data of September 1992
File under Integrated Circuits, IC01

1995 Dec 19

Sound fader control circuit

TEA6320

FEATURES

- Source selector for four stereo and one mono inputs
- Interface for noise reduction circuits
- Interface for external equalizer
- Volume, balance and fader control
- Special loudness characteristic automatically controlled in combination with volume setting
- Bass and treble control
- Mute control at audio signal zero crossing
- Fast mute control via I²C-bus
- Fast mute control via pin
- I²C-bus control for all functions
- Power supply with internal power-on reset.



GENERAL DESCRIPTION

The sound fader control circuit TEA6320 is an I²C-bus controlled stereo preamplifier for car radio hi-fi sound applications.

QUICK REFERENCE DATA

SYMBOL	PARAMETER	CONDITIONS	MIN.	TYP.	MAX.	UNIT
V _{CC}	supply voltage		7.5	8.5	9.5	V
I _{CC}	supply current	V _{CC} = 8.5 V	–	26	–	mA
V _{o(rms)}	maximum output voltage level	V _{CC} = 8.5 V; THD ≤ 0.1%	–	2000	–	mV
G _v	voltage gain		–86	–	+20	dB
G _{step(vol)}	step resolution (volume)		–	1	–	dB
G _{bass}	bass control		–15	–	+15	dB
G _{treble}	treble control		–12	–	+12	dB
G _{step(treble)}	step resolution (bass, treble)		–	1.5	–	dB
(S+N)/N	signal-plus-noise to noise ratio	V _O = 2.0 V; G _v = 0 dB; unweighted	–	105	–	dB
RR ₁₀₀	ripple rejection	V _{r(rms)} < 200 mV; f = 100 Hz; G _v = 0 dB	–	76	–	dB
α _{CS}	channel separation	250 Hz ≤ f ≤ 10 kHz; G _v = 0 dB	90	96	–	dB

ORDERING INFORMATION

TYPE NUMBER	PACKAGE		
	NAME	DESCRIPTION	VERSION
TEA6320	SDIP32	plastic shrink dual in-line package; 32 leads (400 mil)	SOT232-1
TEA6320T	SO32	plastic small outline package; 32 leads; body width 7.5 mm	SOT287-1

Sound fader control circuit

TEA6320

BLOCK DIAGRAM

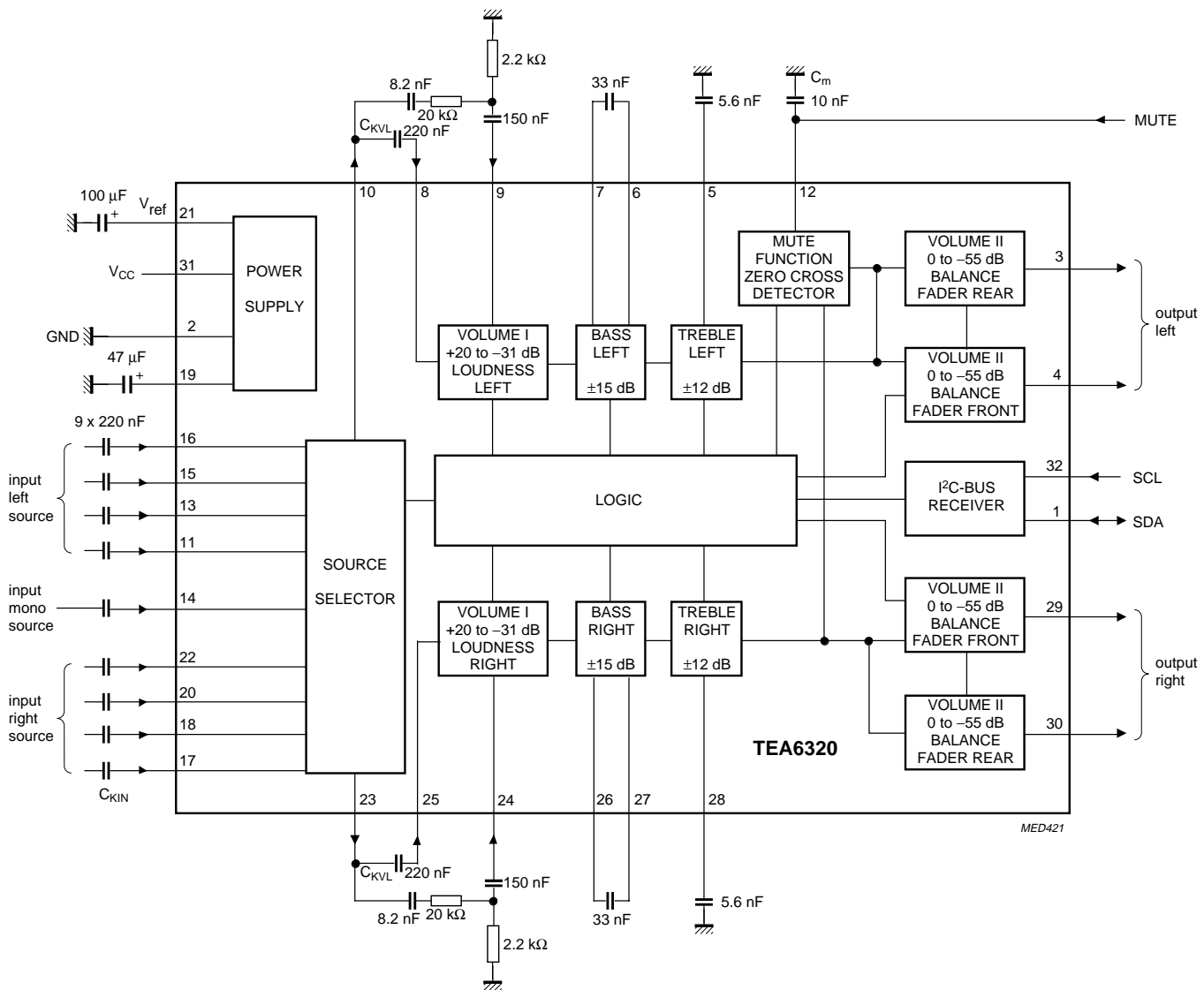

MED421

Fig.1 Block diagram.

Sound fader control circuit

TEA6320

PINNING

SYMBOL	PIN	DESCRIPTION
SDA	1	serial data input/output
GND	2	ground
OUTLR	3	output left rear
OUTLF	4	output left front
TL	5	treble control capacitor left channel or input from an external equalizer
B2L	6	bass control capacitor left channel or output to an external equalizer
B1L	7	bass control capacitor, left channel
IVL	8	input volume I, left control part
ILL	9	input loudness, left control part
QSL	10	output source selector, left channel
IDL	11	input D left source
MUTE	12	mute control
ICL	13	input C left source
IMO	14	input mono source
IBL	15	input B left source
IAL	16	input A left source
IAR	17	input A right source
IBR	18	input B right source
CAP	19	electronic filtering for supply
ICR	20	input C right source
V _{ref}	21	reference voltage (0.5V _{CC})
IDR	22	input D right source
QSR	23	output source selector right channel
ILR	24	input loudness right channel
IVR	25	input volume I, right control part
B1R	26	bass control capacitor right channel
B2R	27	bass control capacitor right channel or output to an external equalizer
TR	28	treble control capacitor right channel or input from an external equalizer
OUTRF	29	output right front
OUTRR	30	output right rear
V _{CC}	31	supply voltage
SCL	32	serial clock input

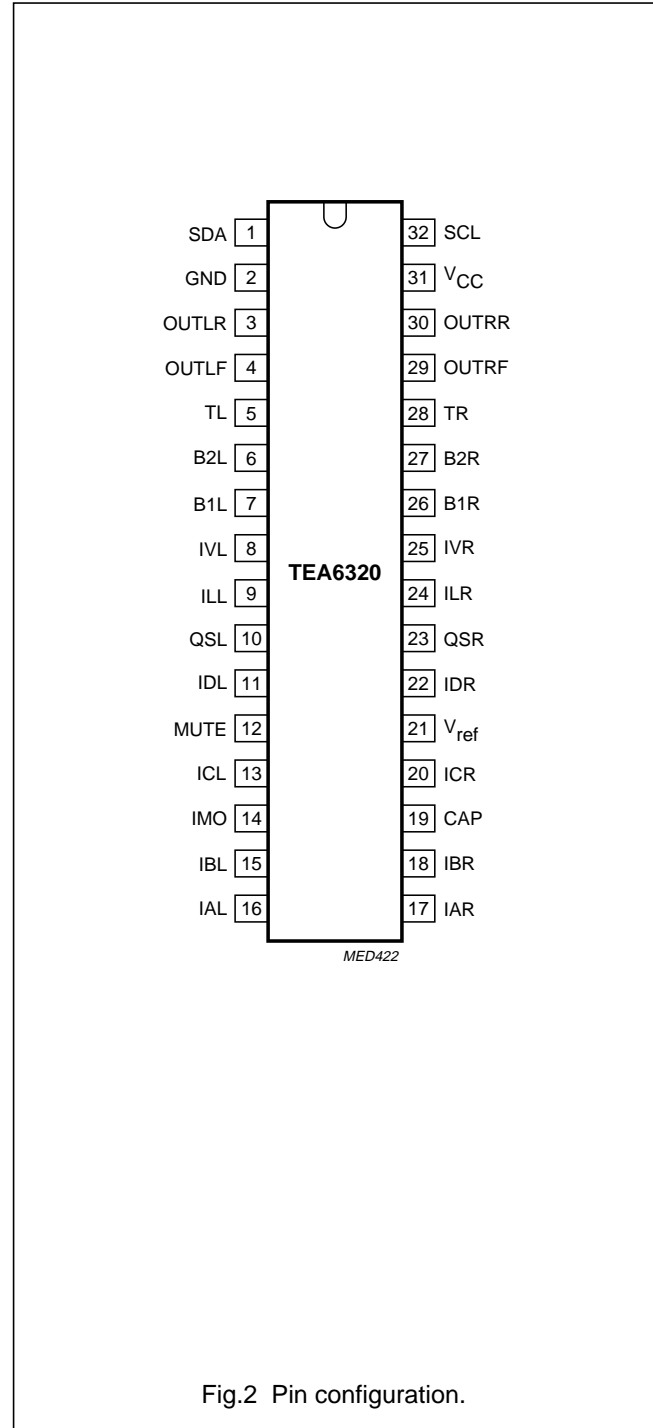

Fig.2 Pin configuration.

Sound fader control circuit

TEA6320

FUNCTIONAL DESCRIPTION

The source selector selects one of 4 stereo inputs or the mono input. The maximum input signal voltage is $V_{i(\text{rms})} = 2 \text{ V}$. The outputs of the source selector and the inputs of the following volume control parts are available at pins 8 and 10 for the left channel and pins 23 and 25 for the right channel. This offers the possibility of interfacing a noise reduction system.

The volume control function is split into two sections: volume I control block and volume II control block.

The control range of volume I is between +20 dB and -31 dB in steps of 1 dB. The volume II control range is between 0 dB and -55 dB in steps of 1 dB. Although the theoretical possible control range is 106 dB (+20 to -86 dB), in practice a range of 86 dB (+20 to -66 dB) is recommended. The gain/attenuation setting of the volume I control block is common for both channels.

The volume I control block operates in combination with the loudness control. The filter is linear when the maximum gain for the volume I control (+20 dB) is selected. The filter characteristic increases automatically over a range of 32 dB down to a setting of -12 dB. That means the maximum filter characteristic is obtained at -12 dB setting of volume I. Further reduction of the volume does not further influence the filter characteristic (see Fig.5). The maximum selected filter characteristic is determined by external components. The proposed application gives a maximum boost of 17 dB for bass and 4.5 dB for treble. The loudness may be switched on or off via I²C-bus control (see Table 7).

The volume I control block is followed by the bass control block. A single external capacitor of 33 nF for each channel in combination with internal resistors, provides the frequency response of the bass control (see Fig.3). The adjustable range is between -15 and +15 dB at 40 Hz.

Both loudness and bass control result in a maximum bass boost of 32 dB for low volume settings.

The treble control block offers a control range between -12 and +12 dB in steps of 1.5 dB at 15 kHz. The filter characteristic is determined by a single capacitor of 5.6 nF for each channel in combination with internal resistors (see Fig.4).

The basic step width of bass and treble control is 3 dB. The intermediate steps are obtained by switching 1.5 dB boost and 1.5 dB attenuation steps.

The bass and treble control functions can be switched off via I²C-bus. In this event the internal signal flow is disconnected. The connections B2L and B2R are outputs

and TL and TR are inputs for inserting an external equalizer.

The last section of the circuit is the volume II block. The balance and fader functions are performed using the same control blocks. This is realized by 4 independently controllable attenuators, one for each output. The control range of these attenuators is 55 dB in steps of 1 dB with an additional mute step.

The circuit provides 3 mute modes:

1. Zero crossing mode mute via I²C-bus using 2 independent zero crossing detectors (ZCM, see Tables 2 and 9 and Fig.16).
2. Fast mute via MUTE pin (see Fig.10).
3. Fast mute via I²C-bus either by general mute (GMU, see Tables 2 and 9) or volume II block setting (see Table 4).

The mute function is performed immediately if ZCM is cleared (ZCM = 0). If the bit is set (ZCM = 1) the mute is activated after changing the GMU bit. The actual mute switching is delayed until the next zero crossing of the audio frequency signal. As the two audio channels (left and right) are independent, two comparators are built-in to control independent mute switches.

To avoid a large delay of mute switching when very low frequencies are processed, the maximum delay time is limited to typically 100 ms by an integrated timing circuit and an external capacitor ($C_m = 10 \text{ nF}$, see Fig.10). This timing circuit is triggered by reception of a new data word for the switch function which includes the GMU bit. After a discharge and charge period of an external capacitor the muting switch follows the GMU bit if no zero crossing was detected during that time.

The mute function can also be controlled externally. If the mute pin is switched to ground all outputs are muted immediately (hardware mute). This mute request overwrites all mute controls via the I²C-bus for the time the pin is held LOW. The hardware mute position is not stored in the TEA6320.

For the turn on/off behaviour the following explanation is generally valid. To avoid AF output caused by the input signal coming from preceding stages, which produces output during drop of V_{CC} , the mute has to be set, before the V_{CC} will drop. This can be achieved by I²C-bus control or by grounding the MUTE pin.

For use where is no mute in the application before turn off, a supply voltage drop of more than $1 \times V_{BE}$ will result in a mute during the voltage drop.

Sound fader control circuit

TEA6320

The power supply should include a V_{CC} buffer capacitor, which provides a discharging time constant. If the input signal does not disappear after turn off the input will become audible after certain time. A 4.7 k Ω resistor discharges the V_{CC} buffer capacitor, because the internal current of the IC does not discharge it completely.

The hardware mute function is favourable for use in Radio Data System (RDS) applications. The zero crossing mute avoids modulation plops. This feature is an advantage for mute during changing presets and/or sources (e.g. traffic announcement during cassette playback).

LIMITING VALUES

In accordance with the Absolute Maximum Rating System (IEC 134).

SYMBOL	PARAMETER	CONDITIONS	MIN.	MAX.	UNIT
V_{CC}	supply voltage		0	10	V
V_n	voltage at all pins except pin 2 referenced to GND (pin 2)		0	V_{CC}	V
T_{amb}	operating ambient temperature		-40	+85	$^{\circ}\text{C}$
T_{stg}	storage temperature		-65	+150	$^{\circ}\text{C}$
V_{es}	electrostatic handling	note 1			

Note

- Human body model: $C = 100 \text{ pF}$; $R = 1.5 \text{ k}\Omega$; $V \geq 2 \text{ kV}$. Charge device model: $C = 200 \text{ pF}$; $R = 0 \text{ }\Omega$; $V \geq 500 \text{ V}$.

Sound fader control circuit

TEA6320

CHARACTERISTICS

$V_{CC} = 8.5\text{ V}$; $R_S = 600\ \Omega$; $R_L = 10\text{ k}\Omega$; $C_L = 2.5\text{ nF}$; AC coupled; $f = 1\text{ kHz}$; $T_{amb} = 25\text{ }^\circ\text{C}$; gain control $G_v = 0\text{ dB}$; bass linear; treble linear; fader off; balance in mid position; loudness off; unless otherwise specified.

SYMBOL	PARAMETER	CONDITIONS	MIN.	TYP.	MAX.	UNIT
V_{CC}	supply voltage		7.5	8.5	9.5	V
I_{CC}	supply current		–	26	33	mA
V_{DC}	internal DC voltage at inputs and outputs		3.83	4.25	4.68	V
V_{ref}	internal reference voltage at pin 21		–	4.25	–	V
$G_{v(max)}$	maximum voltage gain	$R_S = 0\ \Omega$; $R_L = \infty$	19	20	21	dB
$V_{o(rms)}$	output voltage level for P_{max} at the power output stage start of clipping	THD $\leq 0.5\%$; see Fig.11	–	2000	–	mV
		THD = 1%	2300	–	–	mV
		$R_L = 2\text{ k}\Omega$; $C_L = 10\text{ nF}$; THD = 1%	2000	–	–	mV
$V_{i(rms)}$	input sensitivity	$V_o = 2000\text{ mV}$; $G_v = 20\text{ dB}$	–	200	–	mV
f_{ro}	roll-off frequency	$C_{KIN} = 220\text{ nF}$; $C_{KVL} = 220\text{ nF}$; $Z_i = Z_{i(min)}$ low frequency (–1 dB)	60	–	–	Hz
		low frequency (–3 dB)	30	–	–	Hz
		high frequency (–1 dB)	20000	–	–	Hz
		$C_{KIN} = 470\text{ nF}$; $C_{KVL} = 100\text{ nF}$; $Z_i = Z_{i(typ)}$ low frequency (–3 dB)	17	–	–	Hz
α_{cs}	channel separation	$V_i = 2\text{ V}$; frequency range 250 Hz to 10 kHz	90	96	–	dB
THD	total harmonic distortion	frequency range 20 Hz to 12.5 kHz				
		$V_i = 100\text{ mV}$; $G_v = 20\text{ dB}$	–	0.1	–	%
		$V_i = 1\text{ V}$; $G_v = 0\text{ dB}$	–	0.05	0.15	%
		$V_i = 2\text{ V}$; $G_v = 0\text{ dB}$	–	0.1	–	%
RR	ripple rejection	$V_{r(rms)} < 200\text{ mV}$				
		$f = 100\text{ Hz}$	70	76	–	dB
		$f = 40\text{ Hz to }12.5\text{ kHz}$	–	66	–	dB
(S+N)/N	signal-plus-noise to noise ratio	unweighted; 20 Hz to 20 kHz (RMS); $V_o = 2.0\text{ V}$; see Figs 6 and 7	–	105	–	dB
		CCIR468-2 weighted; quasi peak; $V_o = 2.0\text{ V}$				
		$G_v = 0\text{ dB}$	–	95	–	dB
		$G_v = 12\text{ dB}$	–	88	–	dB
	$G_v = 20\text{ dB}$	–	81	–	dB	

Sound fader control circuit

TEA6320

SYMBOL	PARAMETER	CONDITIONS	MIN.	TYP.	MAX.	UNIT
$P_{no(rms)}$	noise output power (RMS value) only contribution of TEA6320; power amplifier for 6 W	mute position; note 1	–	–	10	nW
α_{ct}	crosstalk $\left(20 \log \frac{V_{bus(p-p)}}{V_{o(rms)}} \right)$ between bus inputs and signal outputs	note 2	–	110	–	dB
Source selector						
Z_i	input impedance		25	35	45	k Ω
α_S	input isolation of one selected source to any other input	$f = 1 \text{ kHz}$	–	105	–	dB
		$f = 12.5 \text{ kHz}$	–	95	–	dB
$V_{i(rms)}$	maximum input voltage (RMS value)	THD < 0.5%; $V_{CC} = 8.5 \text{ V}$	–	2.15	–	V
		THD < 0.5%; $V_{CC} = 7.5 \text{ V}$	–	1.8	–	V
V_{offset}	DC offset voltage at source selector output by selection of any inputs		–	–	10	mV
Z_o	output impedance		–	80	120	Ω
R_L	output load resistance		10	–	–	k Ω
C_L	output load capacity		0	–	2500	pF
G_v	voltage gain, source selector		–	0	–	dB
Control part (source selector disconnected; source resistance 600 Ω)						
Z_i	input impedance volume input		100	150	200	k Ω
	input impedance loudness input		25	33	40	k Ω
Z_o	output impedance		–	80	120	Ω
R_L	output load resistance		2	–	–	k Ω
C_L	output load capacity		0	–	10	nF
R_{DCL}	DC load resistance at output to ground		4.7	–	–	k Ω
$V_{i(rms)}$	maximum input voltage (RMS value)	THD < 0.5%	–	2.15	–	V
V_{no}	noise output voltage	CCIR468-2 weighted; quasi peak				
		$G_v = 20 \text{ dB}$	–	110	220	μV
		$G_v = 0 \text{ dB}$	–	33	50	μV
		$G_v = -66 \text{ dB}$	–	13	22	μV
		mute position	–	10	–	μV
CR_{tot}	total continuous control range		–	106	–	dB
	recommended control range		–	86	–	dB
G_{step}	step resolution		–	1	–	dB
	step error between any adjoining step		–	–	0.5	dB

Sound fader control circuit

TEA6320

SYMBOL	PARAMETER	CONDITIONS	MIN.	TYP.	MAX.	UNIT
ΔG_a	attenuator set error	$G_v = +20$ to -50 dB	–	–	2	dB
		$G_v = -51$ to -66 dB	–	–	3	dB
ΔG_t	gain tracking error	$G_v = +20$ to -50 dB	–	–	2	dB
$MUTE_{att}$	mute attenuation	see Fig.10	100	110	–	dB
V_{offset}	DC step offset between any adjoining step	$G_v = 0$ to -66 dB	–	0.2	10	mV
		$G_v = 20$ to 0 dB	–	2	15	mV
	DC step offset between any step to mute	$G_v = 0$ to -66 dB	–	–	10	mV
Volume I control and loudness						
CR_{vol}	continuous volume control range		–	51	–	dB
G_v	voltage gain		–31	–	+20	dB
G_{step}	step resolution		–	1	–	dB
L_{Bmax}	maximum loudness boost	loudness on; referred to loudness off; boost is determined by external components				
		$f = 40$ Hz	–	17	–	dB
		$f = 10$ kHz	–	4.5	–	dB
Bass control						
G_{bass}	bass control, maximum boost	$f = 40$ Hz	14	15	16	dB
	maximum attenuation	$f = 40$ Hz	14	15	16	dB
G_{step}	step resolution (toggle switching)	$f = 40$ Hz	–	1.5	–	dB
	step error between any adjoining step	$f = 40$ Hz	–	–	0.5	dB
V_{offset}	DC step offset in any bass position		–	–	20	mV
Treble control						
G_{treble}	treble control, maximum boost	$f = 15$ kHz	11	12	13	dB
	maximum attenuation	$f = 15$ kHz	11	12	13	dB
	maximum boost	$f > 15$ kHz	–	–	15	dB
G_{step}	step resolution (toggle switching)	$f = 15$ kHz	–	1.5	–	dB
	step error between any adjoining step	$f = 15$ kHz	–	–	0.5	dB
V_{offset}	DC step offset in any treble position		–	–	10	mV
Volume II, balance and fader control						
CR	continuous attenuation fader and volume control range		53.5	55	56.5	dB
G_{step}	step resolution		–	1	2	dB
	attenuation set error		–	–	1.5	dB

Sound fader control circuit

TEA6320

SYMBOL	PARAMETER	CONDITIONS	MIN.	TYP.	MAX.	UNIT
Mute function (see Fig.10)						
HARDWARE MUTE						
V_{sw}	mute switch level ($2 \times V_{BE}$)		–	1.45	–	V
<i>mute active</i>						
V_{swLOW}	input level		–	–	1.0	V
I_i	input current	$V_{swLOW} = 1\text{ V}$	–300	–	–	μA
<i>mute passive: level internally defined</i>						
V_{swHIGH}	saturation voltage		–	–	V_{CC}	V
$t_{d(mute)}$	delay until mute passive		–	–	0.5	ms
ZERO CROSSING MUTE						
I_d	discharge current		0.3	0.6	1.2	μA
I_{ch}	charge current		–300	–150	–	μA
V_{swDEL}	delay switch level ($3 \times V_{BE}$)		–	2.2	–	V
t_d	delay time	$C_m = 10\text{ nF}$	–	100	–	ms
V_{wind}	window for audio signal zero crossing detection		–	30	40	mV
Muting at power supply drop						
V_{CCdrop}	supply drop for mute active		–	$V_{19} - 0.7$	–	V
Power-on reset (when reset is active the GMU-bit (general mute) is set and the I²C-bus receiver is in reset position)						
V_{CC}	increasing supply voltage start of reset		–	–	2.5	V
	end of reset		5.2	6.5	7.2	V
	decreasing supply voltage start of reset		4.2	5.5	6.2	V
Digital part (I²C-bus pins); note 3						
V_{iH}	HIGH level input voltage		3	–	9.5	V
V_{iL}	LOW level input voltage		–0.3	–	+1.5	V
I_{iH}	HIGH level input current		–10	–	+10	μA
I_{iL}	LOW level input current		–10	–	+10	μA
V_{oL}	LOW level output voltage	$I_L = 3\text{ mA}$	–	–	0.4	V

Notes to the characteristics

- The indicated values for output power assume a 6 W power amplifier at 4 Ω with 20 dB gain and a fixed attenuator of 12 dB in front of it. Signal-to-noise ratios exclude noise contribution of the power amplifier.
- The transmission contains: total initialization with MAD and subaddress for volume and 8 data words, see also definition of characteristics, clock frequency = 50 kHz, repetition burst rate = 400 Hz, maximum bus signal amplitude = 5 V (p-p).
- The AC characteristics are in accordance with the I²C-bus specification. This specification, "The I²C-bus and how to use it", can be ordered using the code 9398 393 40011.

Sound fader control circuit

TEA6320

I²C-BUS PROTOCOL

I²C-bus format

S ⁽¹⁾	SLAVE ADDRESS ⁽²⁾	A ⁽³⁾	SUBADDRESS ⁽⁴⁾	A ⁽³⁾	DATA ⁽⁵⁾	A ⁽³⁾	P ⁽⁶⁾
------------------	------------------------------	------------------	---------------------------	------------------	---------------------	------------------	------------------

Notes

1. S = START condition.
2. SLAVE ADDRESS (MAD) = 1000 0000.
3. A = acknowledge, generated by the slave.
4. SUBADDRESS (SAD), see Table 1.
5. DATA, see Table 1; if more than 1 byte of DATA is transmitted, then auto-increment of the significant subaddress is performed.
6. P = STOP condition.

Table 1 Second byte after MAD

FUNCTION	BIT	MSB						LSB	
		7	6	5	4	3	2 ⁽¹⁾	1 ⁽¹⁾	0 ⁽¹⁾
Volume/loudness	V	0	0	0	0	0	0	0	0
Fader front right	FFR	0	0	0	0	0	0	0	1
Fader front left	FFL	0	0	0	0	0	0	1	0
Fader rear right	FRR	0	0	0	0	0	0	1	1
Fader rear left	FRL	0	0	0	0	0	1	0	0
Bass	BA	0	0	0	0	0	1	0	1
Treble	TR	0	0	0	0	0	1	1	0
Switch	S	0	0	0	0	0	1	1	1

Note

1. Significant subaddress.

Sound fader control circuit

TEA6320

Table 2 Definition of third byte after MAD and SAD

FUNCTION	BIT	MSB								LSB	
		7	6	5	4	3	2	1	0		
Volume/loudness	V	ZCM ⁽¹⁾	LOFF ⁽²⁾	V5 ⁽³⁾	V4 ⁽³⁾	V3 ⁽³⁾	V2 ⁽³⁾	V1 ⁽³⁾	V0 ⁽³⁾		
Fader front right	FFR	X ⁽⁴⁾	X ⁽⁴⁾	FFR5 ⁽⁵⁾	FFR4 ⁽⁵⁾	FFR3 ⁽⁵⁾	FFR2 ⁽⁵⁾	FFR1 ⁽⁵⁾	FFR0 ⁽⁵⁾		
Fader front left	FFL	X ⁽⁴⁾	X ⁽⁴⁾	FFL5 ⁽⁶⁾	FFL4 ⁽⁶⁾	FFL3 ⁽⁶⁾	FFL2 ⁽⁶⁾	FFL1 ⁽⁶⁾	FFL0 ⁽⁶⁾		
Fader rear right	FRR	X ⁽⁴⁾	X ⁽⁴⁾	FRR5 ⁽⁷⁾	FRR4 ⁽⁷⁾	FRR3 ⁽⁷⁾	FRR2 ⁽⁷⁾	FRR1 ⁽⁷⁾	FRR0 ⁽⁷⁾		
Fader rear left	FRL	X ⁽⁴⁾	X ⁽⁴⁾	FRL5 ⁽⁸⁾	FRL4 ⁽⁸⁾	FRL3 ⁽⁸⁾	FRL2 ⁽⁸⁾	FRL1 ⁽⁸⁾	FRL0 ⁽⁸⁾		
Bass	BA	X ⁽⁴⁾	X ⁽⁴⁾	X ⁽⁴⁾	BA4 ⁽⁹⁾	BA3 ⁽⁹⁾	BA2 ⁽⁹⁾	BA1 ⁽⁹⁾	BA0 ⁽⁹⁾		
Treble	TR	X ⁽⁴⁾	X ⁽⁴⁾	X ⁽⁴⁾	TR4 ⁽¹⁰⁾	TR3 ⁽¹⁰⁾	TR2 ⁽¹⁰⁾	TR1 ⁽¹⁰⁾	TR0 ⁽¹⁰⁾		
Switch	S	GMU ⁽¹¹⁾	X ⁽⁴⁾	X ⁽⁴⁾	X ⁽⁴⁾	X ⁽⁴⁾	SC2 ⁽¹²⁾	SC1 ⁽¹²⁾	SC0 ⁽¹²⁾		

Notes

1. Zero crossing mode.
2. Switch loudness on/off.
3. Volume control.
4. Don't care bits (logic 1 during testing).
5. Fader control front right.
6. Fader control front left.
7. Fader control rear right.
8. Fader control rear left.
9. Bass control.
10. Treble control.
11. Mute control for all outputs (general mute).
12. Source selector control.

Sound fader control circuit

TEA6320

Table 3 Volume I setting

G _v (dB)	DATA					
	V5	V4	V3	V2	V1	V0
Loudness on: the increment of the loudness characteristics is linear at every volume step in the range from +20 to -11 dB						
+20	1	1	1	1	1	1
+19	1	1	1	1	1	0
+18	1	1	1	1	0	1
+17	1	1	1	1	0	0
+16	1	1	1	0	1	1
+15	1	1	1	0	1	0
+14	1	1	1	0	0	1
+13	1	1	1	0	0	0
+12	1	1	0	1	1	1
+11	1	1	0	1	1	0
+10	1	1	0	1	0	1
+9	1	1	0	1	0	0
+8	1	1	0	0	1	1
+7	1	1	0	0	1	0
+6	1	1	0	0	0	1
+5	1	1	0	0	0	0
+4	1	0	1	1	1	1
+3	1	0	1	1	1	0
+2	1	0	1	1	0	1
+1	1	0	1	1	0	0
0	1	0	1	0	1	1
-1	1	0	1	0	1	0
-2	1	0	1	0	0	1
-3	1	0	1	0	0	0
-4	1	0	0	1	1	1
-5	1	0	0	1	1	0
-6	1	0	0	1	0	1
-7	1	0	0	1	0	0
-8	1	0	0	0	1	1
-9	1	0	0	0	1	0
-10	1	0	0	0	0	1
-11	1	0	0	0	0	0

Sound fader control circuit

TEA6320

G _v (dB)	DATA					
	V5	V4	V3	V2	V1	V0
Loudness characteristic is constant in a range from -11 dB to -31 dB						
-12	0	1	1	1	1	1
-13	0	1	1	1	1	0
-14	0	1	1	1	0	1
-15	0	1	1	1	0	0
-16	0	1	1	0	1	1
-17	0	1	1	0	1	0
-18	0	1	1	0	0	1
-19	0	1	1	0	0	0
-20	0	1	0	1	1	1
-21	0	1	0	1	1	0
-22	0	1	0	1	0	1
-23	0	1	0	1	0	0
-24	0	1	0	0	1	1
-25	0	1	0	0	1	0
-26	0	1	0	0	0	1
-27	0	1	0	0	0	0
-28	0	0	1	1	1	1
-29	0	0	1	1	1	0
-30	0	0	1	1	0	1
-31	0	0	1	1	0	0
Repetition of steps in a range from -28 dB to -31 dB						
-28	0	0	1	0	1	1
-29	0	0	1	0	1	0
-30	0	0	1	0	0	1
-31	0	0	1	0	0	0
-28	0	0	0	1	1	1
-29	0	0	0	1	1	0
-30	0	0	0	1	0	1
-31	0	0	0	1	0	0
-28	0	0	0	0	1	1
-29	0	0	0	0	1	0
-30	0	0	0	0	0	1
-31	0	0	0	0	0	0

Sound fader control circuit

TEA6320

Table 4 Volume II setting (fader and balance); note 1

G_v (dB)	DATA					
	FRR5	FRR4	FRR3	FRR2	FRR1	FRR0
	FRL5	FRL4	FRL3	FRL2	FRL1	FRL0
	FFL5	FFL4	FFL3	FFL2	FFL1	FFL0
	FFR5	FFR4	FFR3	FFR2	FFR1	FFR0
0	1	1	1	1	1	1
-1	1	1	1	1	1	0
-2	1	1	1	1	0	1
-3	1	1	1	1	0	0
-4	1	1	1	0	1	1
-5	1	1	1	0	1	0
-6	1	1	1	0	0	1
-7	1	1	1	0	0	0
-8	1	1	0	1	1	1
-9	1	1	0	1	1	0
-10	1	1	0	1	0	1
-11	1	1	0	1	0	0
-12	1	1	0	0	1	1
-13	1	1	0	0	1	0
-14	1	1	0	0	0	1
-15	1	1	0	0	0	0
-16	1	0	1	1	1	1
-17	1	0	1	1	1	0
-18	1	0	1	1	0	1
-19	1	0	1	1	0	0
-20	1	0	1	0	1	1
-21	1	0	1	0	1	0
-22	1	0	1	0	0	1
-23	1	0	1	0	0	0
-24	1	0	0	1	1	1
-25	1	0	0	1	1	0
-26	1	0	0	1	0	1
-27	1	0	0	1	0	0
-28	1	0	0	0	1	1
-29	1	0	0	0	1	0
-30	1	0	0	0	0	1
-31	1	0	0	0	0	0
-32	0	1	1	1	1	1
-33	0	1	1	1	1	0
-34	0	1	1	1	0	1

Sound fader control circuit

TEA6320

G _v (dB)	DATA					
	FRR5	FRR4	FRR3	FRR2	FRR1	FRR0
	FRL5	FRL4	FRL3	FRL2	FRL1	FRL0
	FFL5	FFL4	FFL3	FFL2	FFL1	FFL0
	FFR5	FFR4	FFR3	FFR2	FFR1	FFR0
-35	0	1	1	1	0	0
-36	0	1	1	0	1	1
-37	0	1	1	0	1	0
-38	0	1	1	0	0	1
-39	0	1	1	0	0	0
-40	0	1	0	1	1	1
-41	0	1	0	1	1	0
-42	0	1	0	1	0	1
-43	0	1	0	1	0	0
-44	0	1	0	0	1	1
-45	0	1	0	0	1	0
-46	0	1	0	0	0	1
-47	0	1	0	0	0	0
-48	0	0	1	1	1	1
-49	0	0	1	1	1	0
-50	0	0	1	1	0	1
-51	0	0	1	1	0	0
-52	0	0	1	0	1	1
-53	0	0	1	0	1	0
-54	0	0	1	0	0	1
-55	0	0	1	0	0	0
mute	0	0	0	1	1	1
mute	0	0	0	1	1	0
mute	0	0	0	1	0	1
mute	0	0	0	1	0	0
mute	0	0	0	0	1	1
mute	0	0	0	0	1	0
mute	0	0	0	0	0	1
mute	0	0	0	0	0	0

Note

1. For a particular range the data is always the same, only the subaddress changes.

Sound fader control circuit

TEA6320

Table 5 Bass setting

G _{bass} (dB)	DATA				
	BA4	BA3	BA2	BA1	BA0
+15.0	1	1	1	1	1
+13.5	1	1	1	1	0
+15.0	1	1	1	0	1
+13.5	1	1	1	0	0
+15.0	1	1	0	1	1
+13.5	1	1	0	1	0
+12.0	1	1	0	0	1
+10.5	1	1	0	0	0
+9.0	1	0	1	1	1
+7.5	1	0	1	1	0
+6.0	1	0	1	0	1
+4.5	1	0	1	0	0
+3.0	1	0	0	1	1
+1.5	1	0	0	1	0
0 ⁽¹⁾	1	0	0	0	1
0 ⁽²⁾	1	0	0	0	0
-1.5	0	1	1	1	1
-3.0	0	1	1	1	0
-4.5	0	1	1	0	1
-6.0	0	1	1	0	0
-7.5	0	1	0	1	1
-9.0	0	1	0	1	0
-10.5	0	1	0	0	1
-12.0	0	1	0	0	0
-13.5	0	0	1	1	1
-15.0	0	0	1	1	0
-13.5	0	0	1	0	1
-15.0	0	0	1	0	0
note 3	0	0	0	1	1
note 3	0	0	0	1	0
note 3	0	0	0	0	1
notes 3 and 4	0	0	0	0	0

Notes

1. Recommended data word for step 0 dB.
2. Result of 1.5 dB boost and 1.5 dB attenuation.
3. The last four bass control data words mute the bass response.
4. The last bass control and treble control data words (00000) enable the external equalizer connection.

Sound fader control circuit

TEA6320

Table 6 Treble setting

G_{treble} (dB)	DATA				
	TR4	TR3	TR2	TR1	TR0
+12.0	1	1	1	1	1
+10.5	1	1	1	1	0
+12.0	1	1	1	0	1
+10.5	1	1	1	0	0
+12.0	1	1	0	1	1
+10.5	1	1	0	1	0
+12.0	1	1	0	0	1
+10.5	1	1	0	0	0
+9.0	1	0	1	1	1
+7.5	1	0	1	1	0
+6.0	1	0	1	0	1
+4.5	1	0	1	0	0
+3.0	1	0	0	1	1
+1.5	1	0	0	1	0
0 ⁽¹⁾	1	0	0	0	1
0 ⁽²⁾	1	0	0	0	0
-1.5	0	1	1	1	1
-3.0	0	1	1	1	0
-4.5	0	1	1	0	1
-6.0	0	1	1	0	0
-7.5	0	1	0	1	1
-9.0	0	1	0	1	0
-10.5	0	1	0	0	1
-12.0	0	1	0	0	0
note 3	0	0	1	1	1
note 3	0	0	1	1	0
note 3	0	0	1	0	1
note 3	0	0	1	0	0
note 3	0	0	0	1	1
note 3	0	0	0	1	0
note 3	0	0	0	0	1
notes 3 and 4	0	0	0	0	0

Notes

1. Recommended data word for step 0 dB.
2. Result of 1.5 dB boost and 1.5 dB attenuation.
3. The last eight treble control data words select treble output.
4. The last treble control and bass control data words (00000) enable the external equalizer connection.

Sound fader control circuit

TEA6320

Table 7 Loudness setting

CHARACTERISTIC	DATA LOFF
With loudness	0
Linear	1

Table 8 Selected input

FUNCTION	DATA		
	SC2	SC1	SC0
Stereo inputs IAL and IAR	1	1	1
Stereo inputs IBL and IBR	1	1	0
Stereo inputs ICL and ICR	1	0	1
Stereo inputs IDL and IDR	1	0	0
Mono input IMO	0	X ⁽¹⁾	X ⁽¹⁾

Note

1. X = don't care bits (logic 1 during testing).

Table 9 Mute mode

FUNCTION	DATA	
	GMU	ZCM
Direct mute off	0	0
Mute off delayed until the next zero crossing	0	1
Direct mute	1	0
Mute delayed until the next zero crossing	1	1

Sound fader control circuit

TEA6320

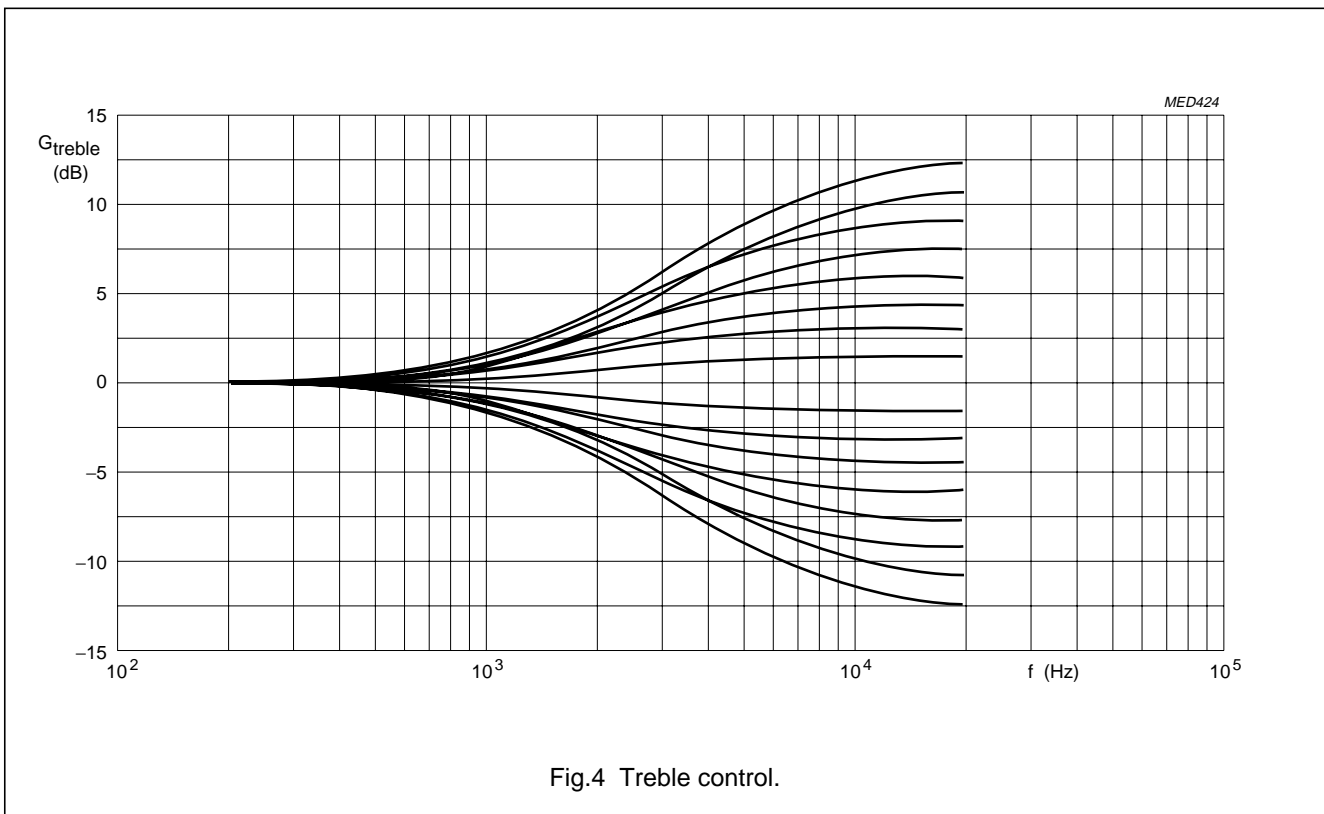
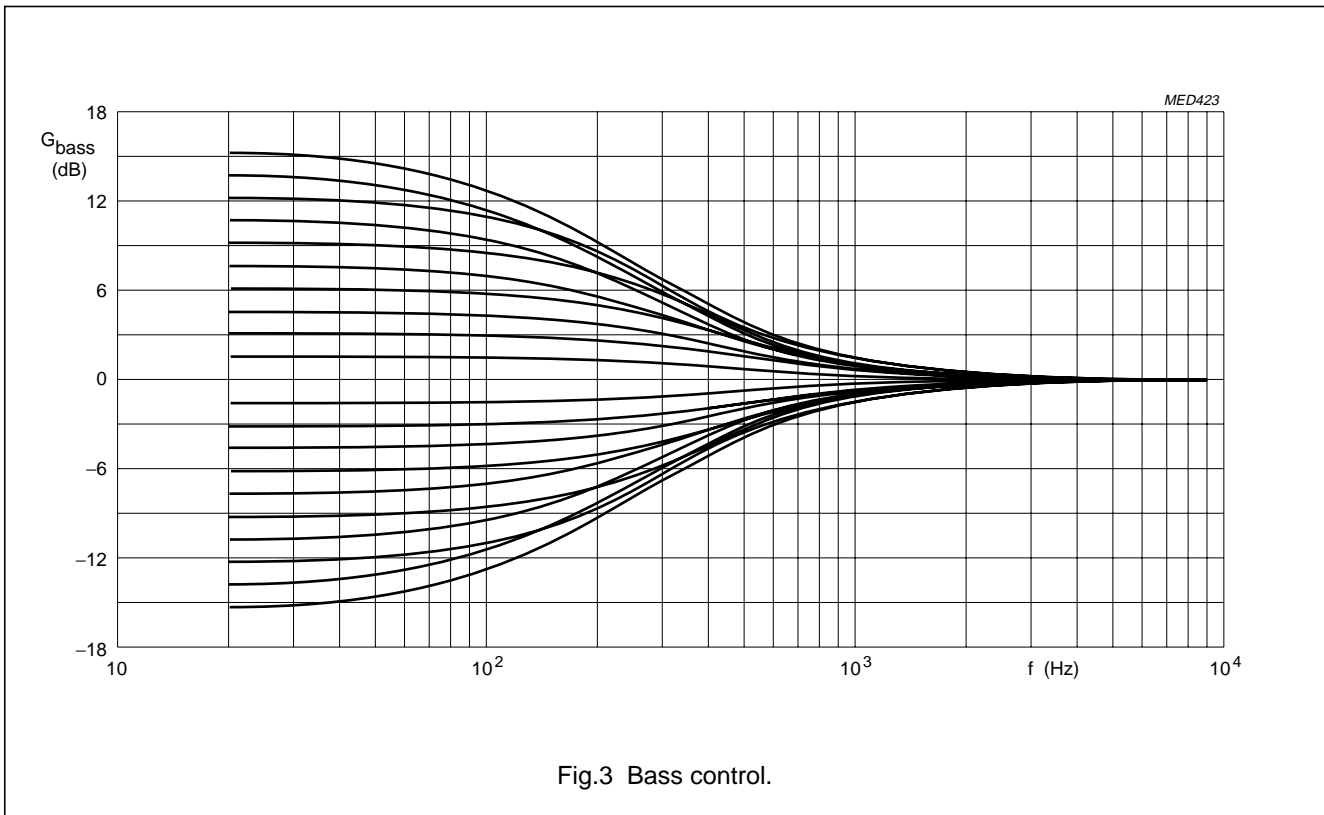

Sound fader control circuit

TEA6320

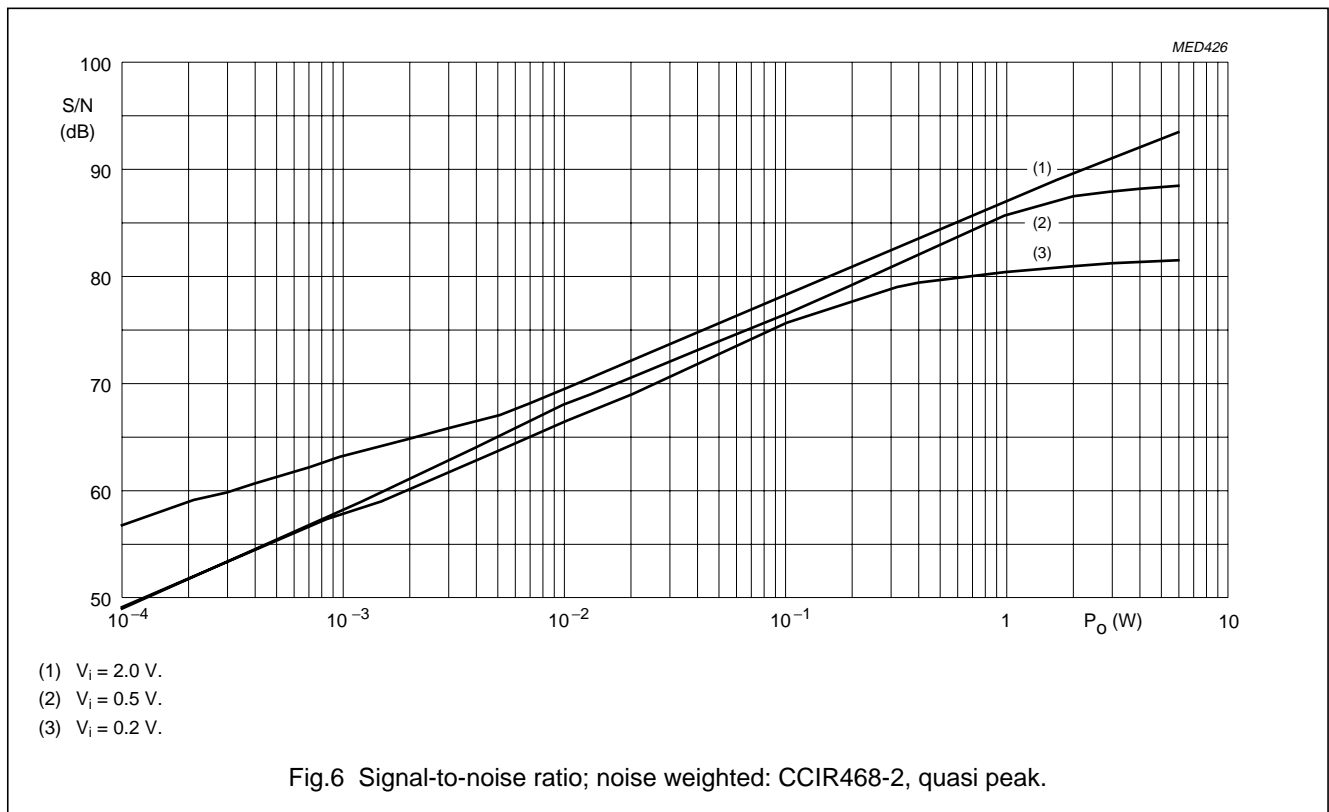
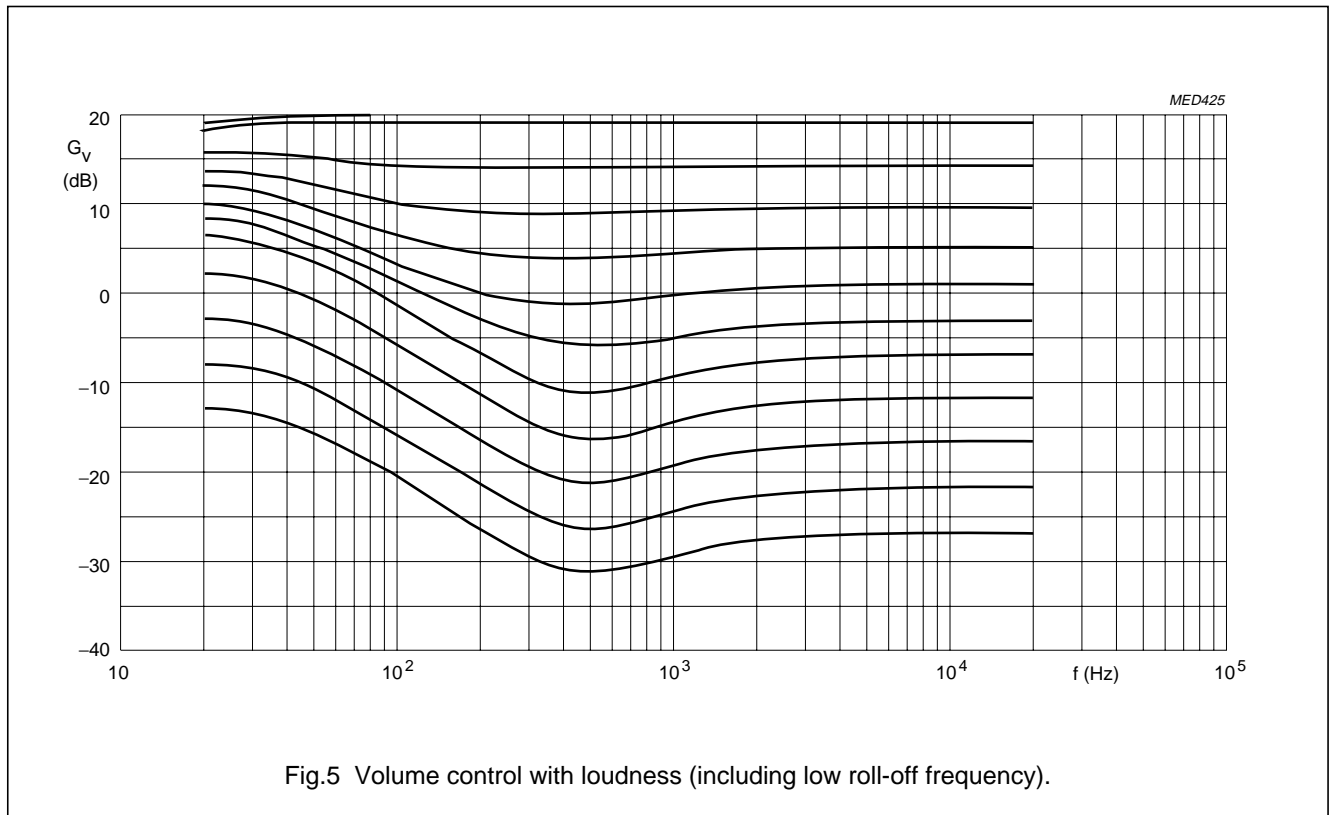

Sound fader control circuit

TEA6320

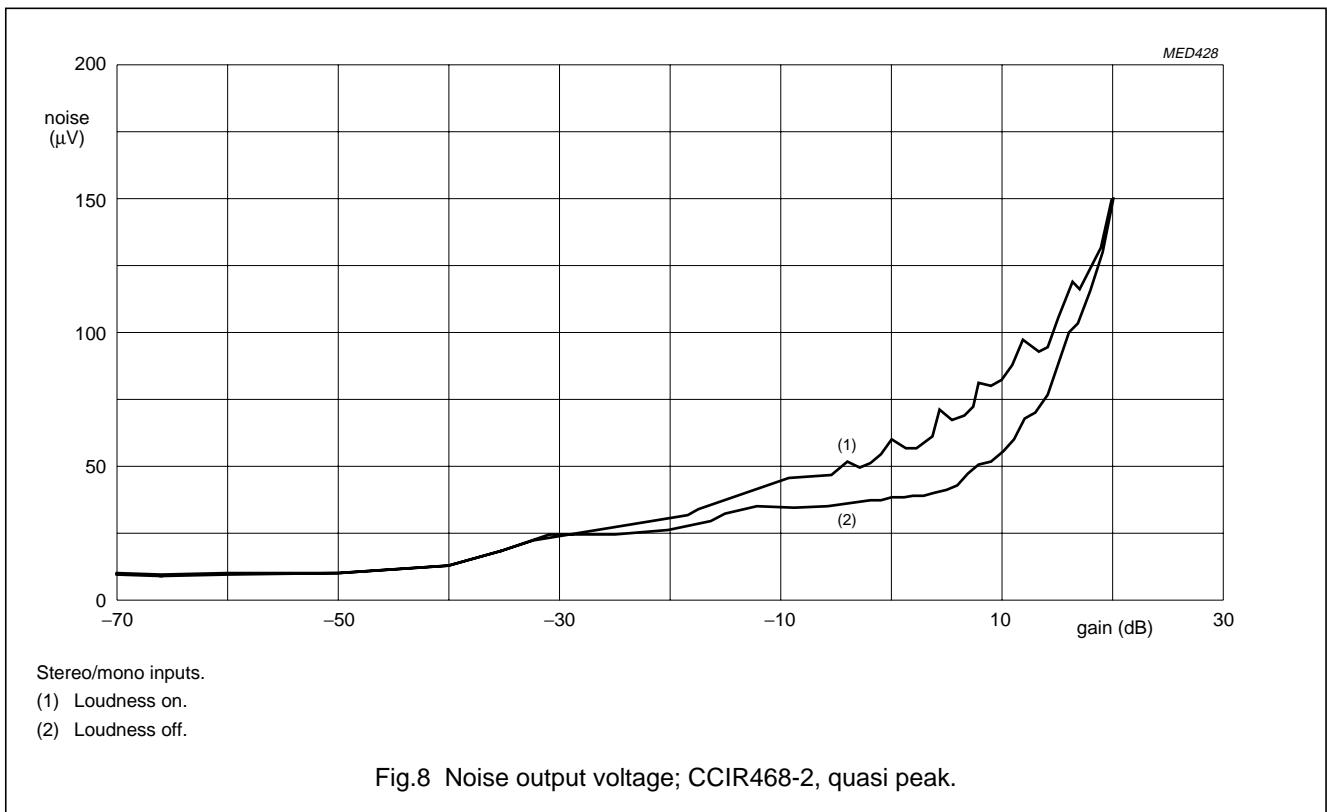
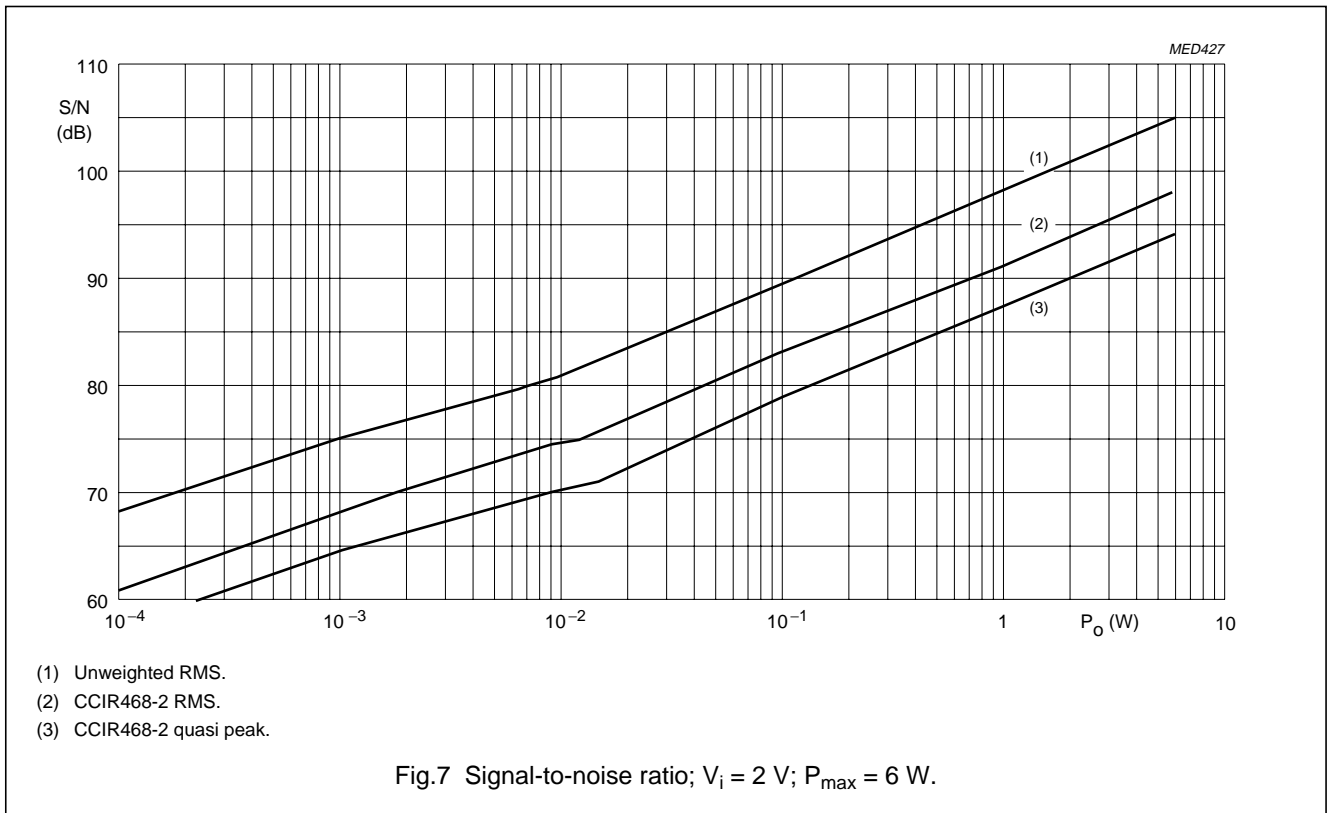

Sound fader control circuit

TEA6320

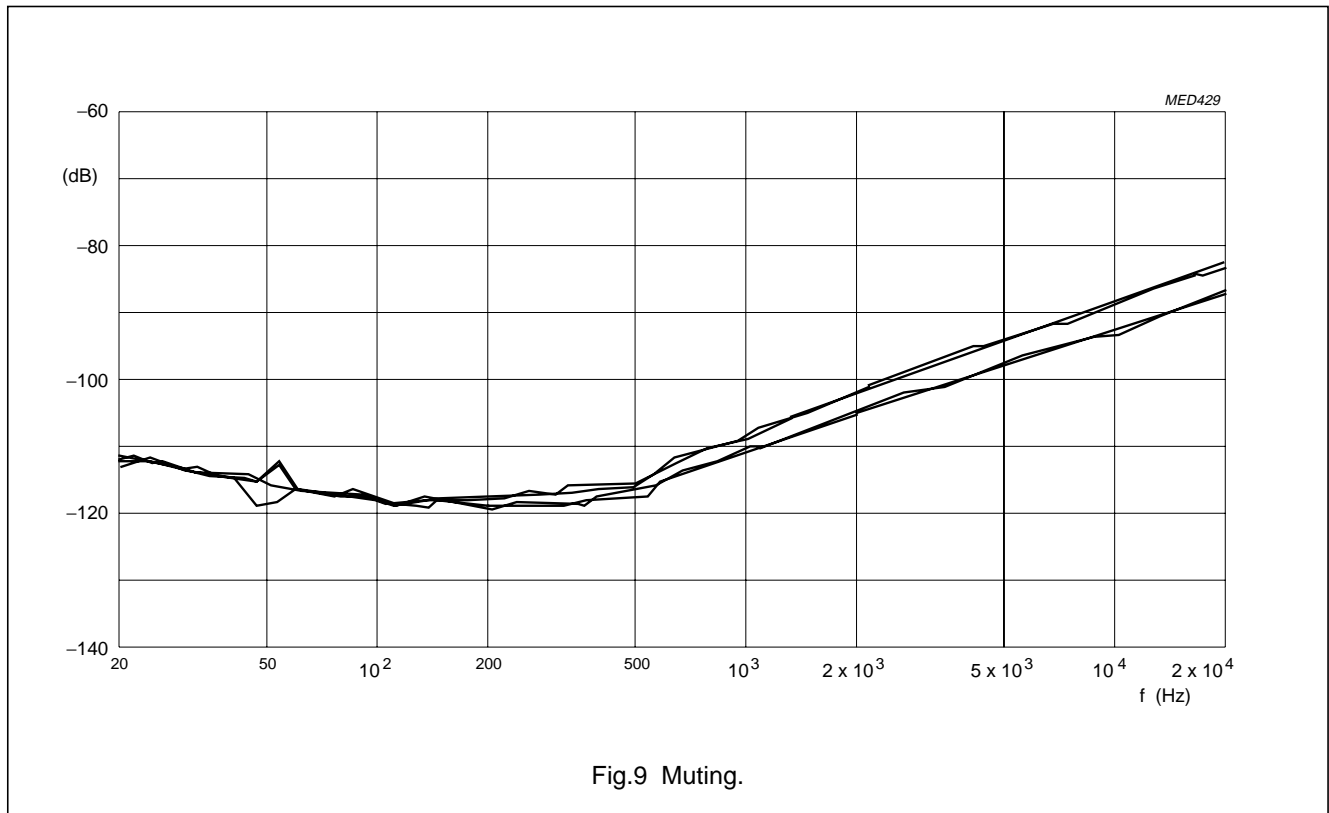

Sound fader control circuit

TEA6320

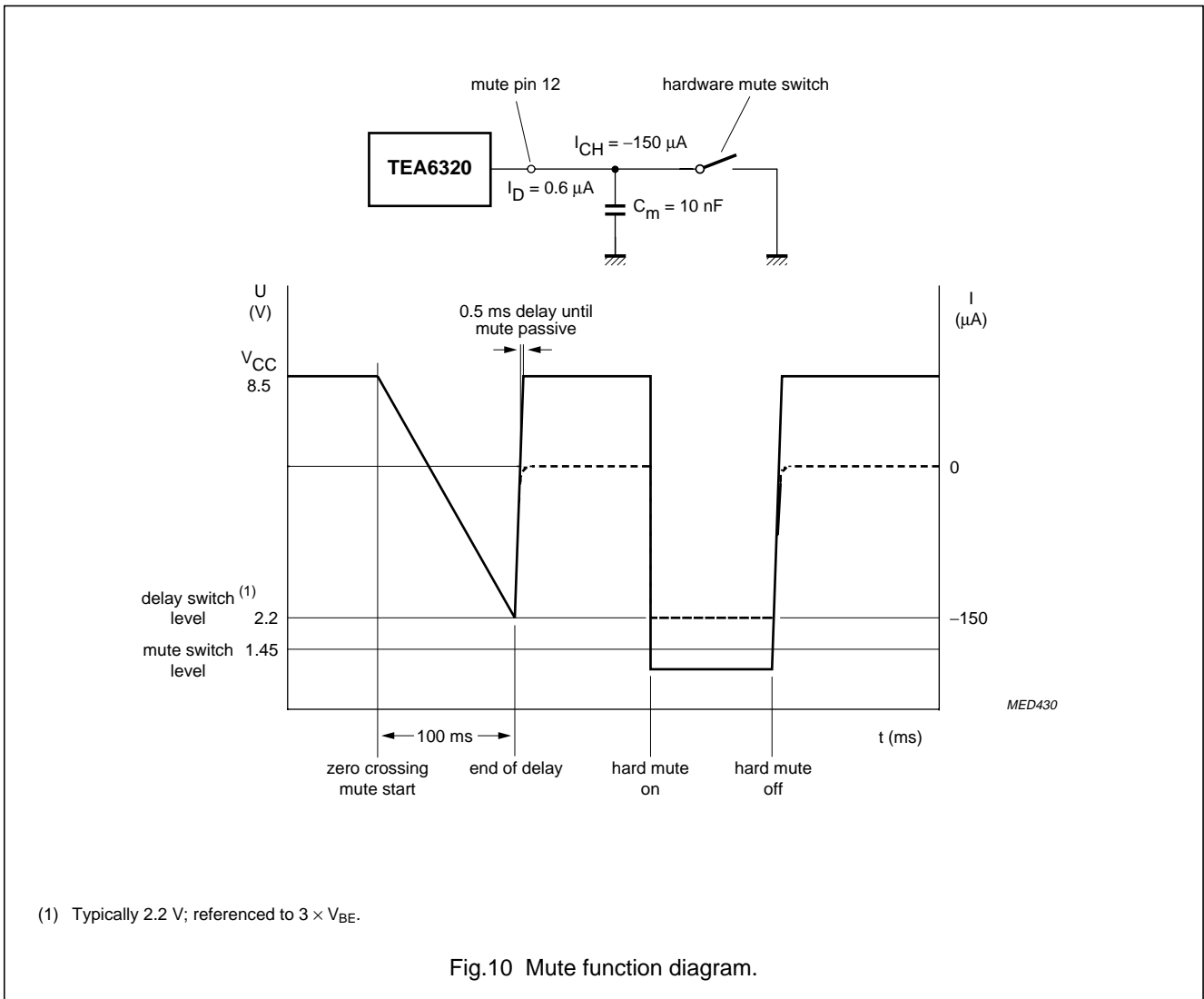

Sound fader control circuit

TEA6320

If the 20 dB gain is not required for the maximum volume position, it will be an advantage to use the maximum boost gain and then increased attenuation in the last section, Volume II.

Therefore the loudness will be at the correct place and a lower noise and offset voltage will be achieved.

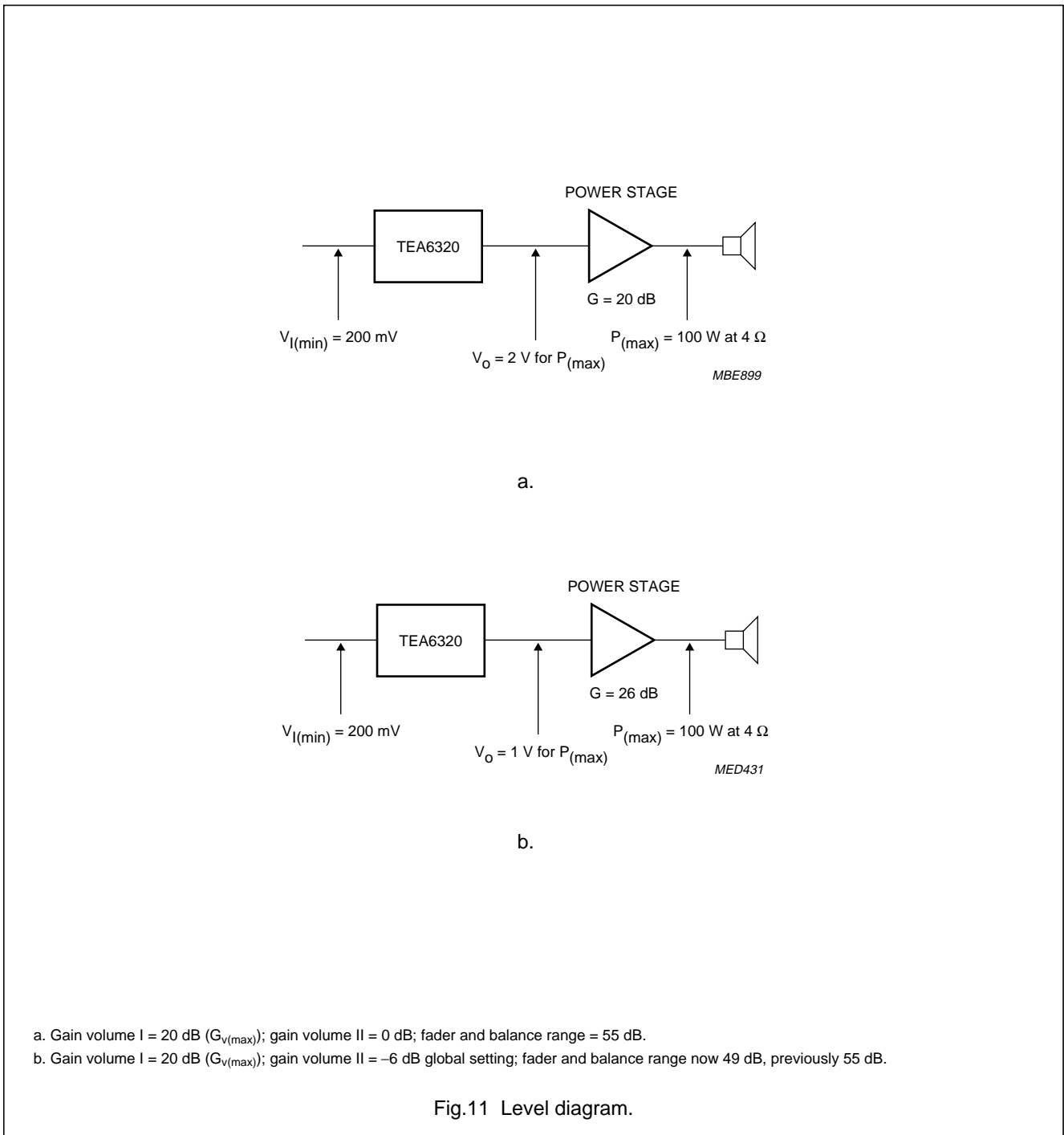

Sound fader control circuit

TEA6320

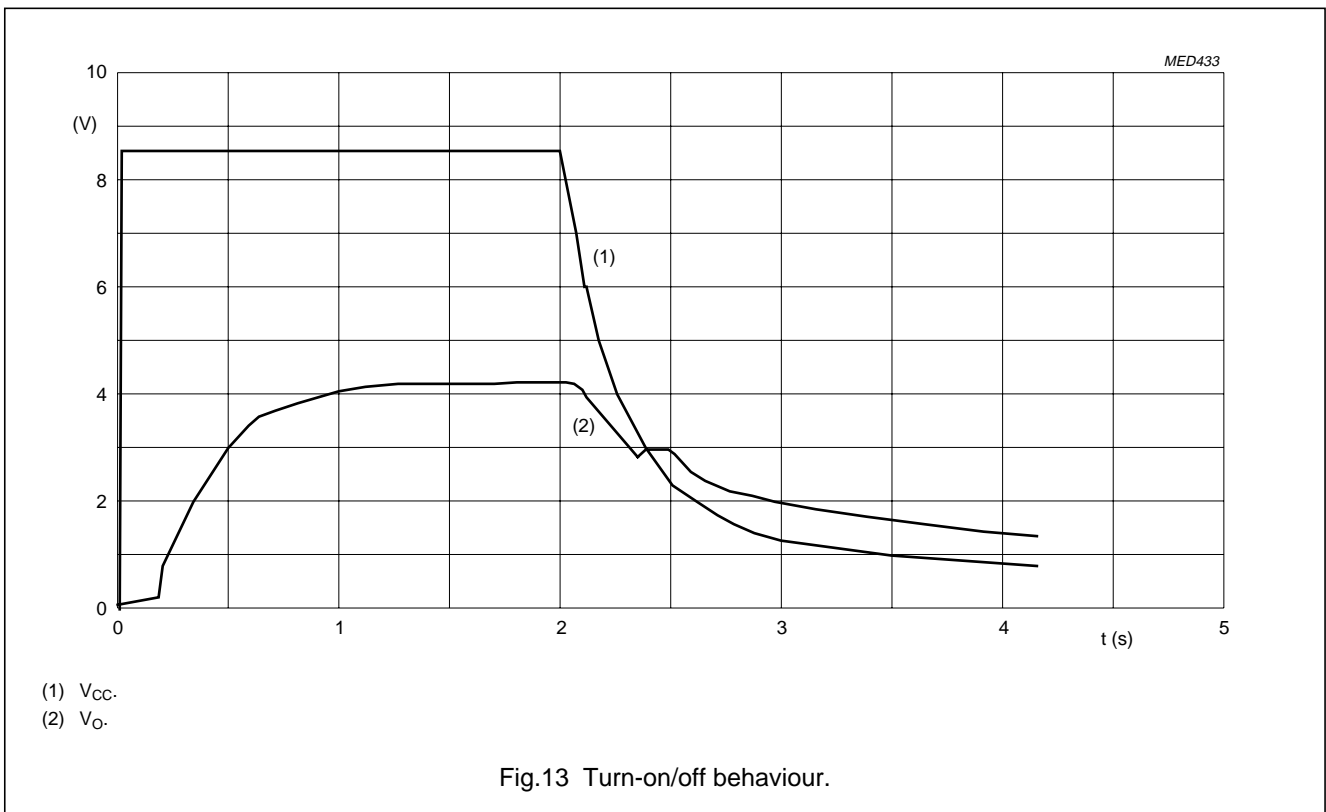
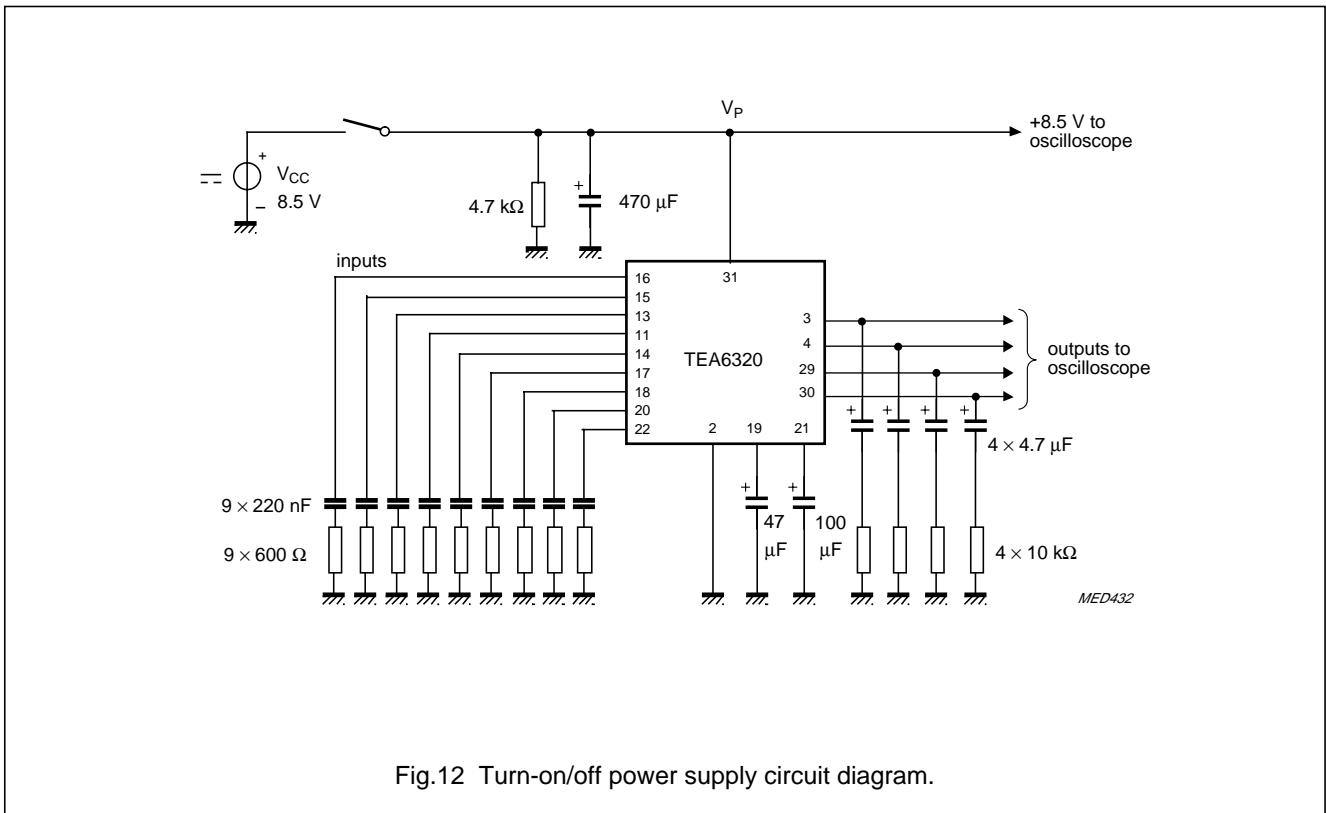

Sound fader control circuit

TEA6320

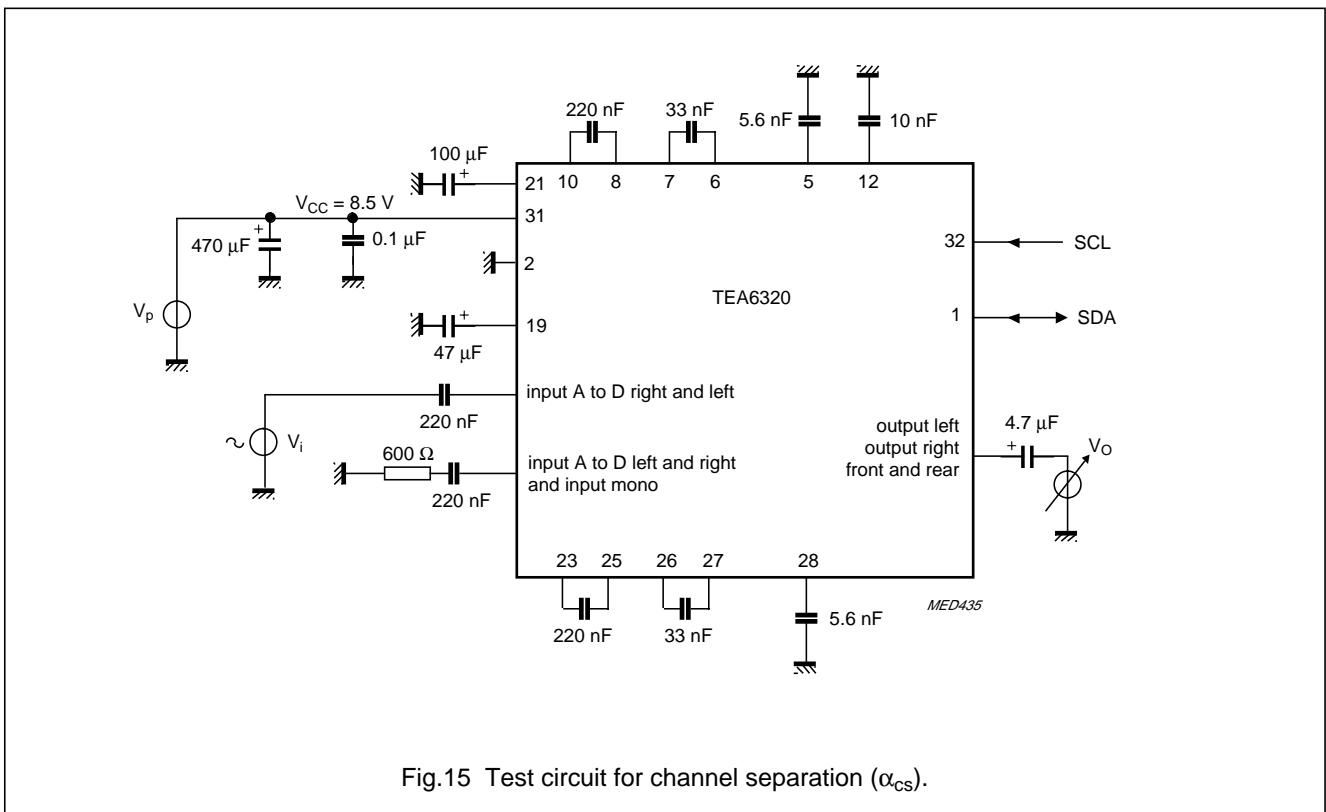
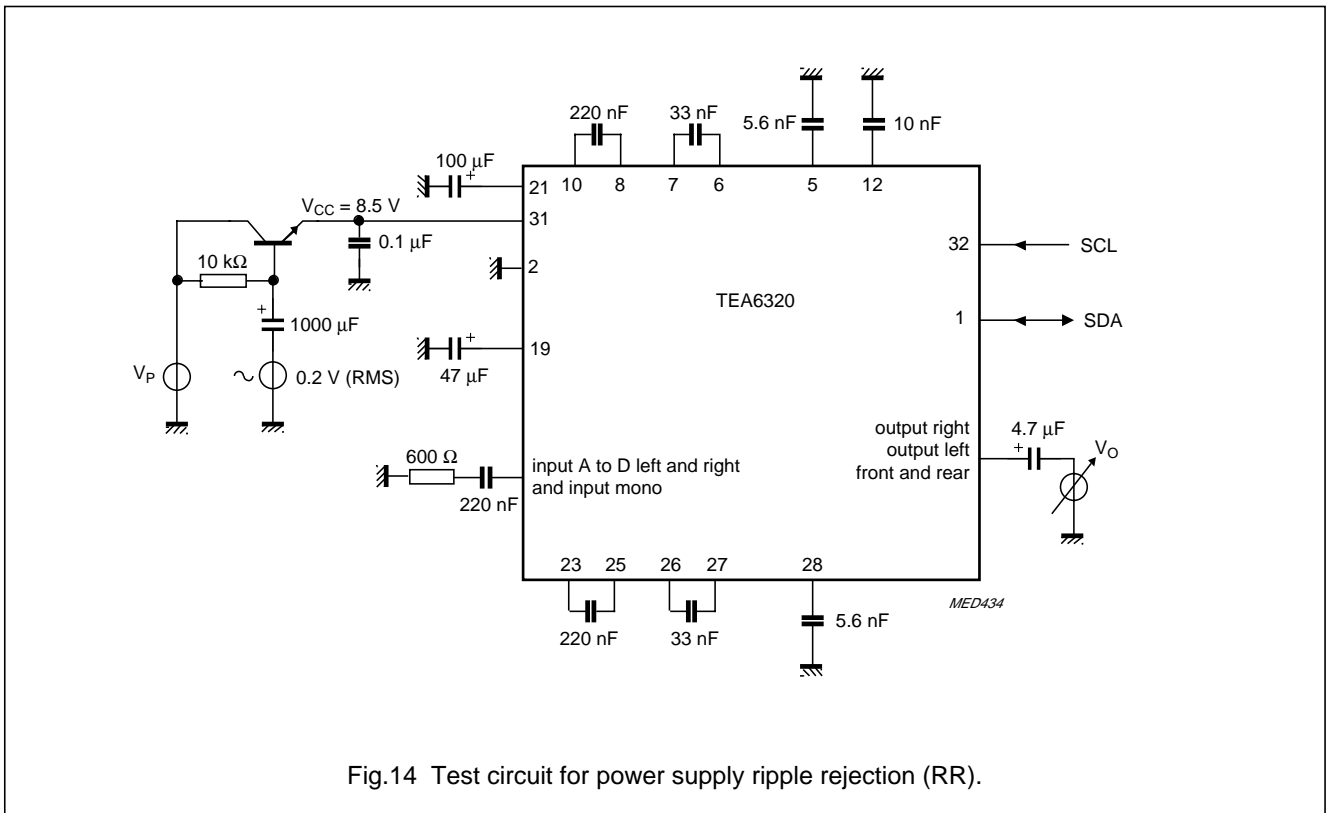

Sound fader control circuit

TEA6320

Selection of input signals by using the zero crossing mute mode

A selection from input A (IAL) to input B (IBL) left sources produces a modulation click depending on the difference of the signal values at the time of switching.

At t_1 the maximum possible difference between signals is 7 V(p-p) (see Fig. 16) and gives a large click. Using the cross detector no modulation click is audible.

For example: The selection is enabled at t_1 , the microcontroller sets the zero cross bit (ZCM = 1) and then the mute bit (GMU = 1) via the I²C-bus. The output signal

follows the input A signal, until the next zero crossing occurs and then activates mute.

After a fixed delay time at t_2 , the microcontroller sends the bits for input switching and mute inactive.

The output signal remains muted until the next signal zero crossing of input B (IBL) occurs, and then follows that signal.

The delay time $t_2 - t_1$ is e.g. 40 ms. Therefore the capacity $C_m = 3.3$ nF. The zero cross function is working at the lowest frequency of 40 Hz determined by the C_m capacitor.

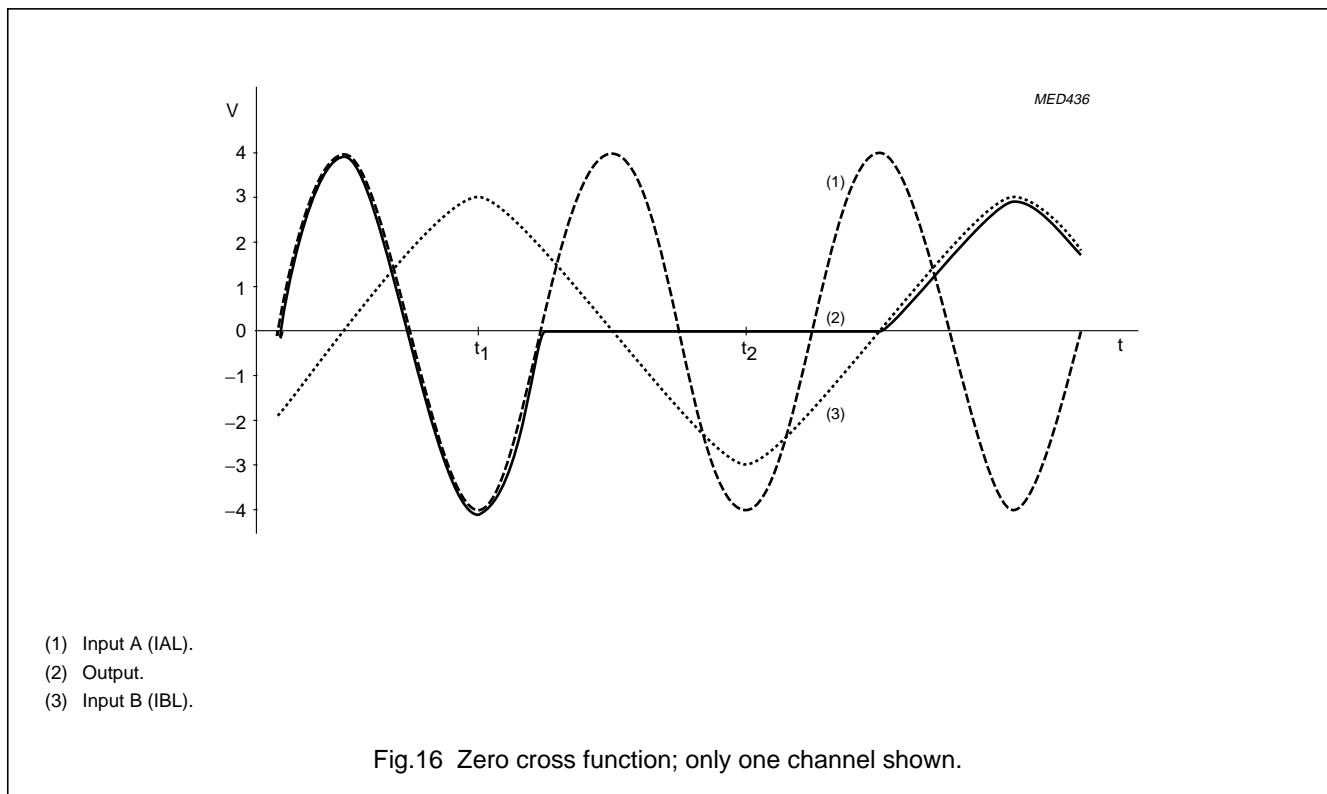

Sound fader control circuit

TEA6320

Loudness filter calculation example

Figure 17 shows the basic loudness circuit with an external low-pass filter application. R1 allows an attenuation range of 21 dB while the boost is determined by the gain stage V₂. Both result in a loudness control range of +20 to -12 dB.

Defining f_{ref} as the frequency where the level does not change while switching loudness on/off. The external resistor R3 for f_{ref} → ∞ can be calculated as:

$$R3 = R1 \frac{10^{\frac{G_v}{20}}}{1 - 10^{\frac{G_v}{20}}}$$

With G_v = -21 dB and R1 = 33 kΩ,

R3 = 3.2 kΩ is generated.

For the low-pass filter characteristic the value of the external capacitor C1 can be determined by setting a specific boost for a defined frequency and referring the gain to G_v at f_{ref} as indicated above.

$$\left| \frac{1}{j(\omega C1)} \right| = \frac{(R1 + R3) \times 10^{\frac{G_v}{20}} - R3}{1 - 10^{\frac{G_v}{20}}}$$

For example: 3 dB boost at f = 1 kHz
 G_v = G_{v(ref)} + 3 dB = -18 dB; f = 1 kHz and C1 = 100 nF.

If a loudness characteristic with additional high frequency boost is desired, an additional high-pass section has to be included in the external filter circuit as indicated in the block diagram. A filter configuration that provides AC coupling avoids offset voltage problems.

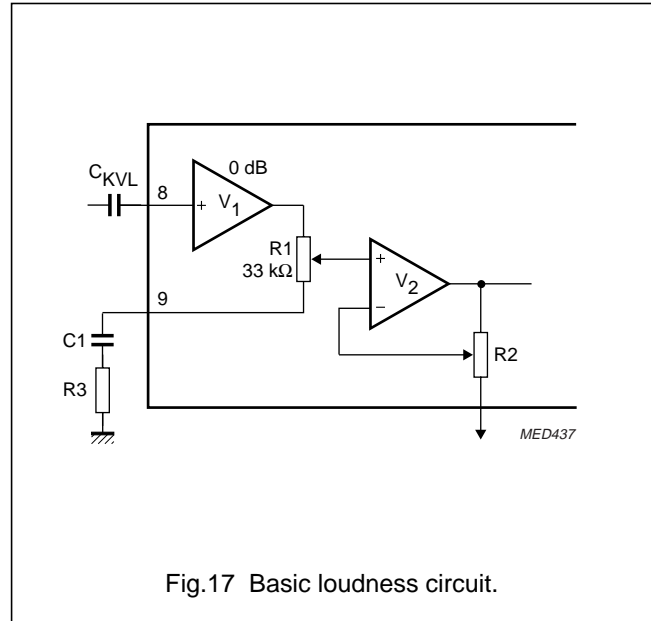

Fig.17 Basic loudness circuit.

Sound fader control circuit

TEA6320

INTERNAL PIN CONFIGURATIONS

Values shown in Figs 18 to 30 are typical DC values;
 $V_{CC} = 8.5 \text{ V}$.

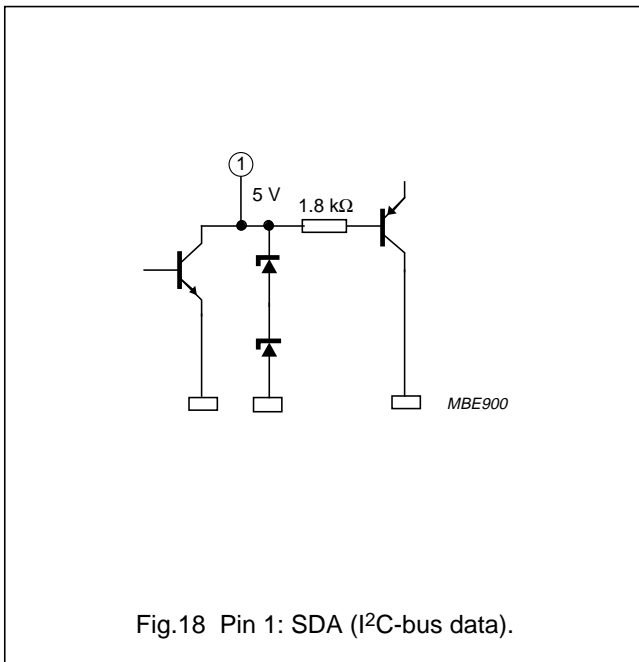

Fig.18 Pin 1: SDA (I²C-bus data).

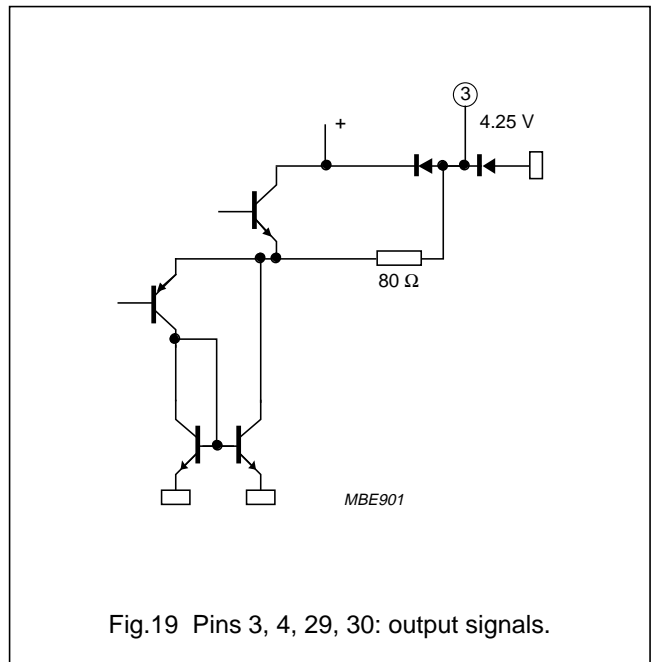

Fig.19 Pins 3, 4, 29, 30: output signals.

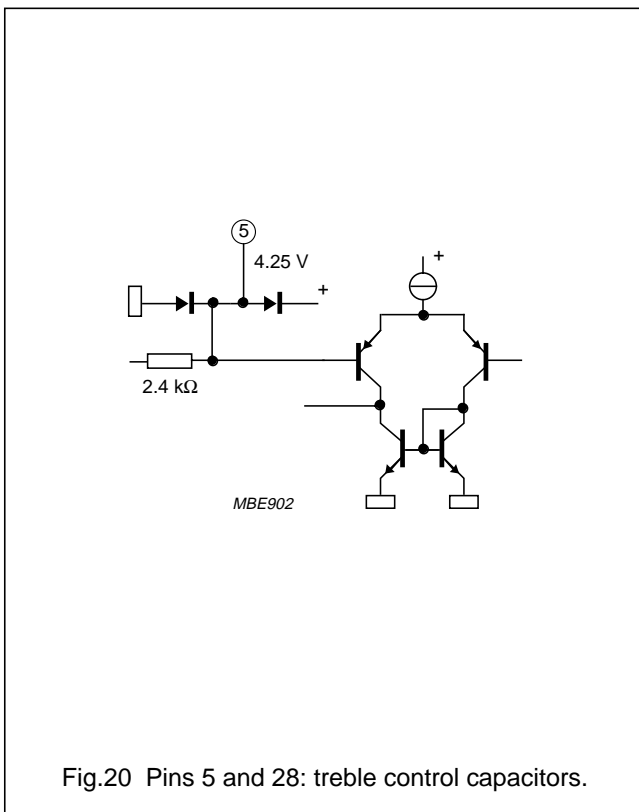

Fig.20 Pins 5 and 28: treble control capacitors.

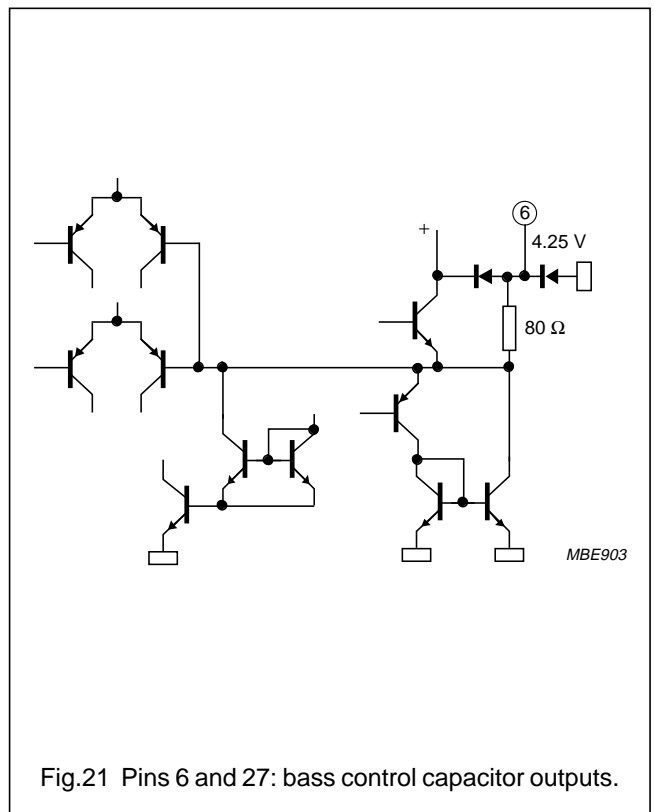
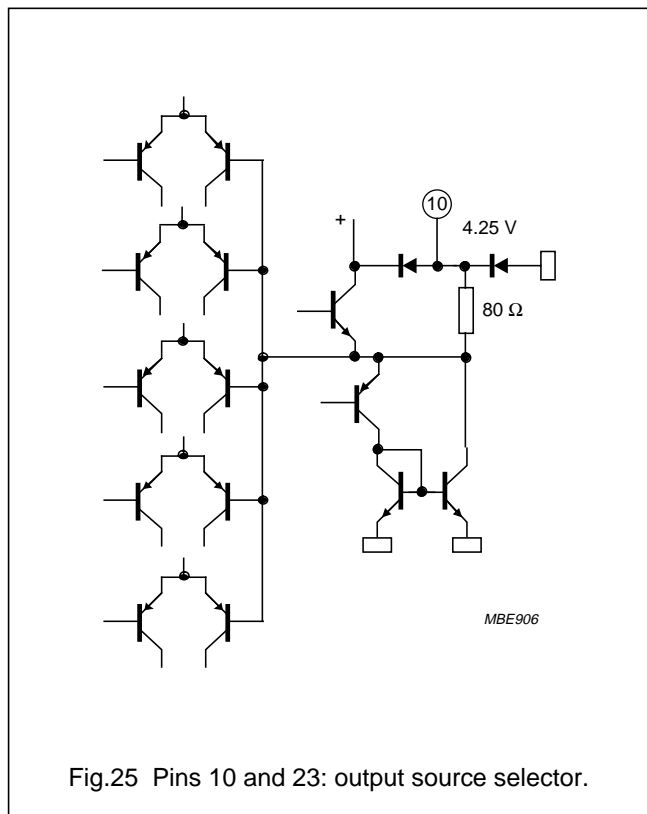
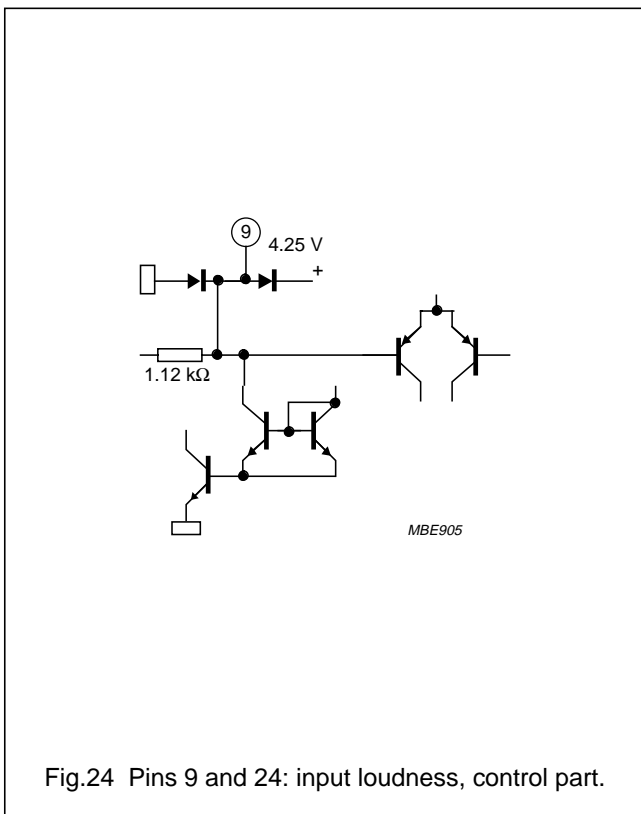
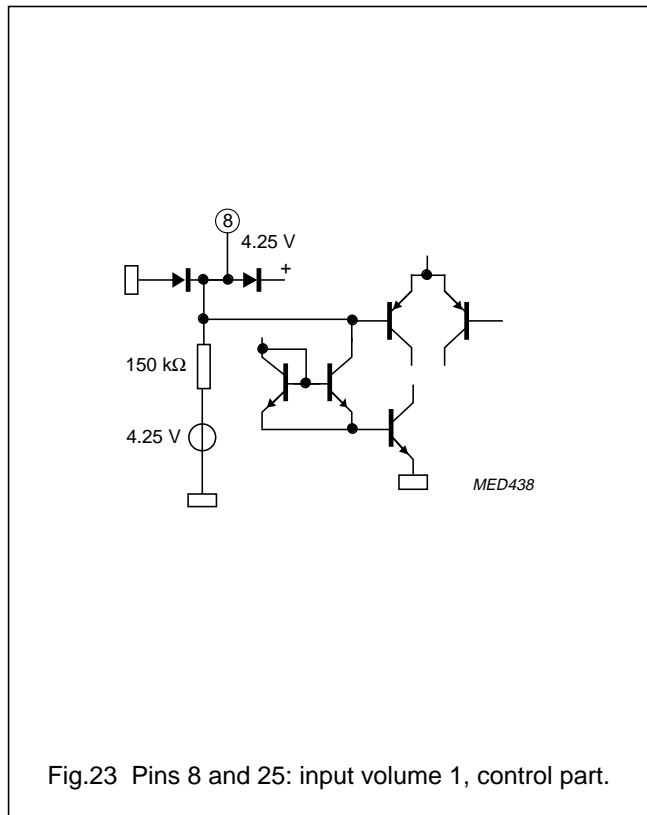
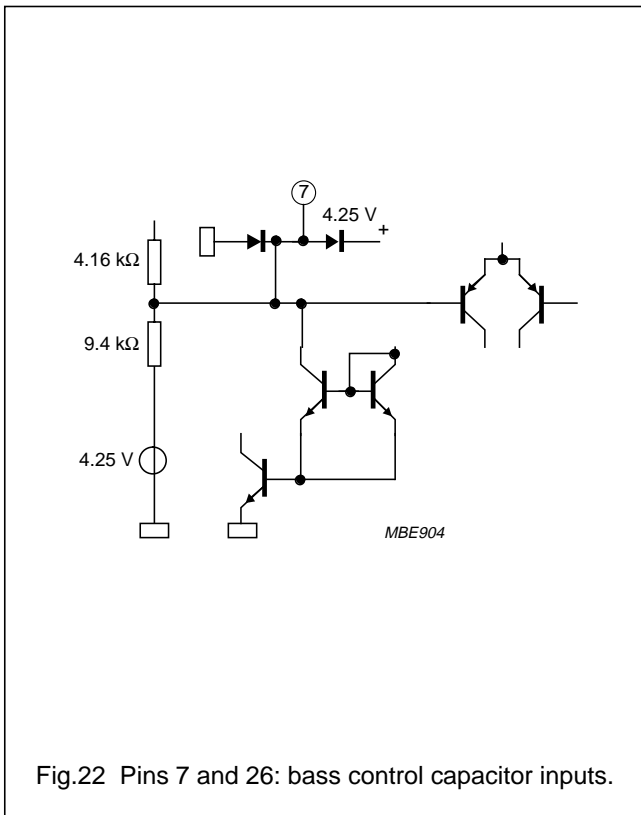

Fig.21 Pins 6 and 27: bass control capacitor outputs.

Sound fader control circuit

TEA6320



Sound fader control circuit

TEA6320

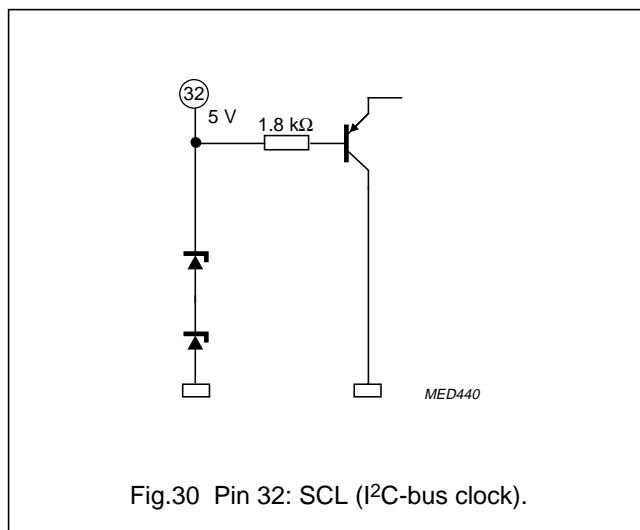
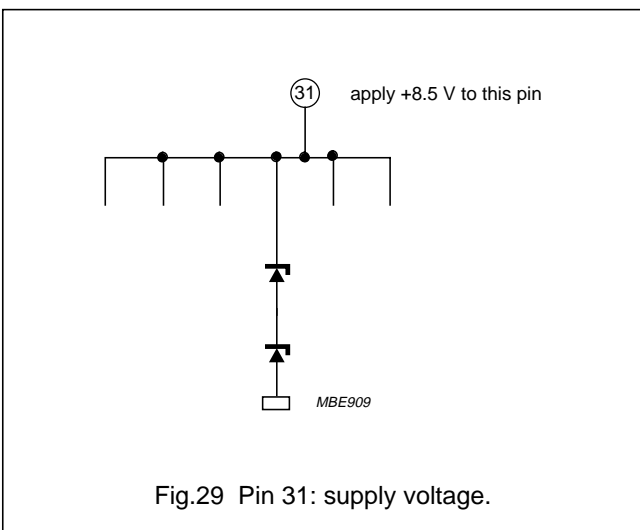
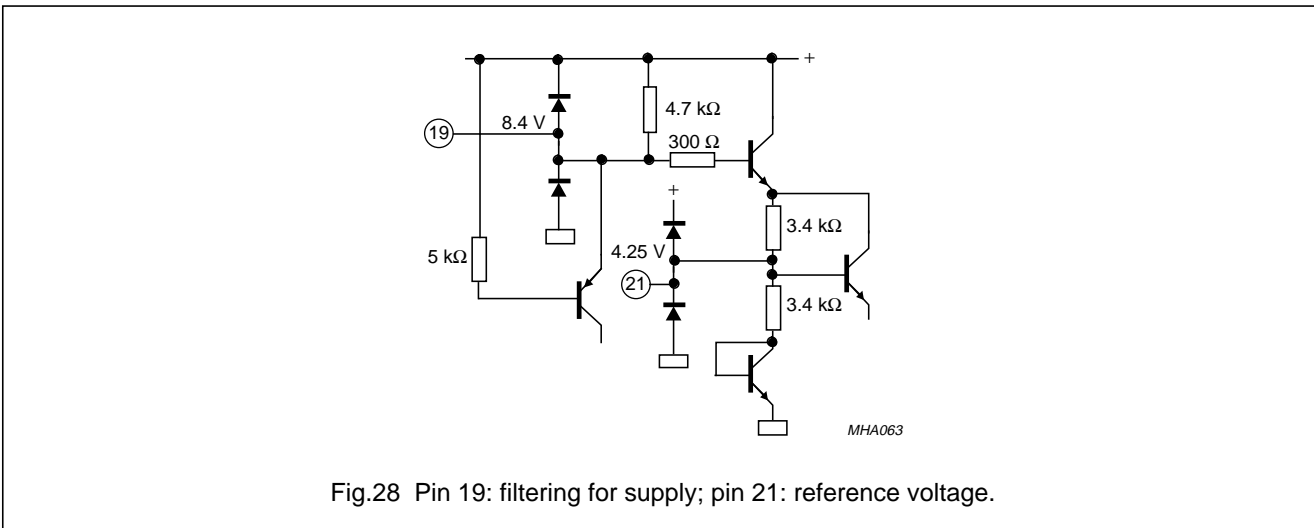
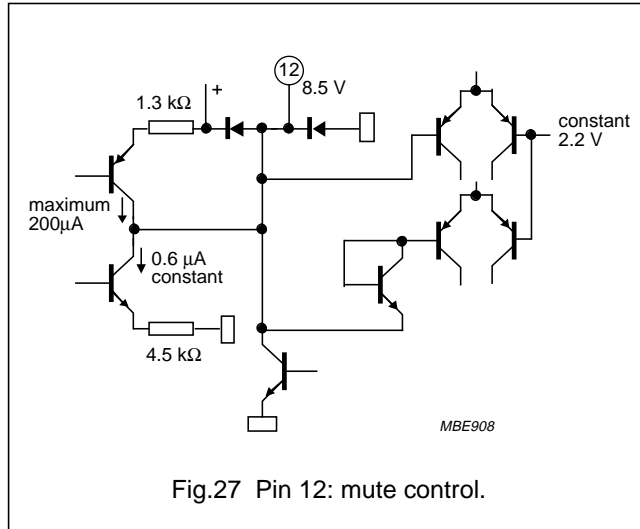
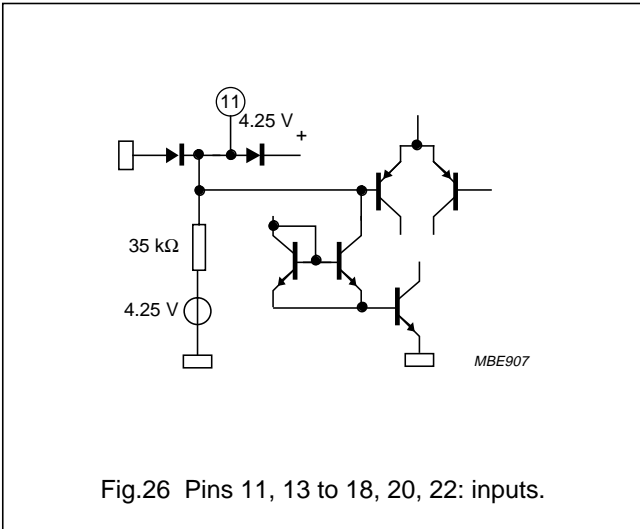

Sound fader control circuit

TEA6320

PACKAGE OUTLINES

SDIP32: plastic shrink dual in-line package; 32 leads (400 mil)

SOT232-1

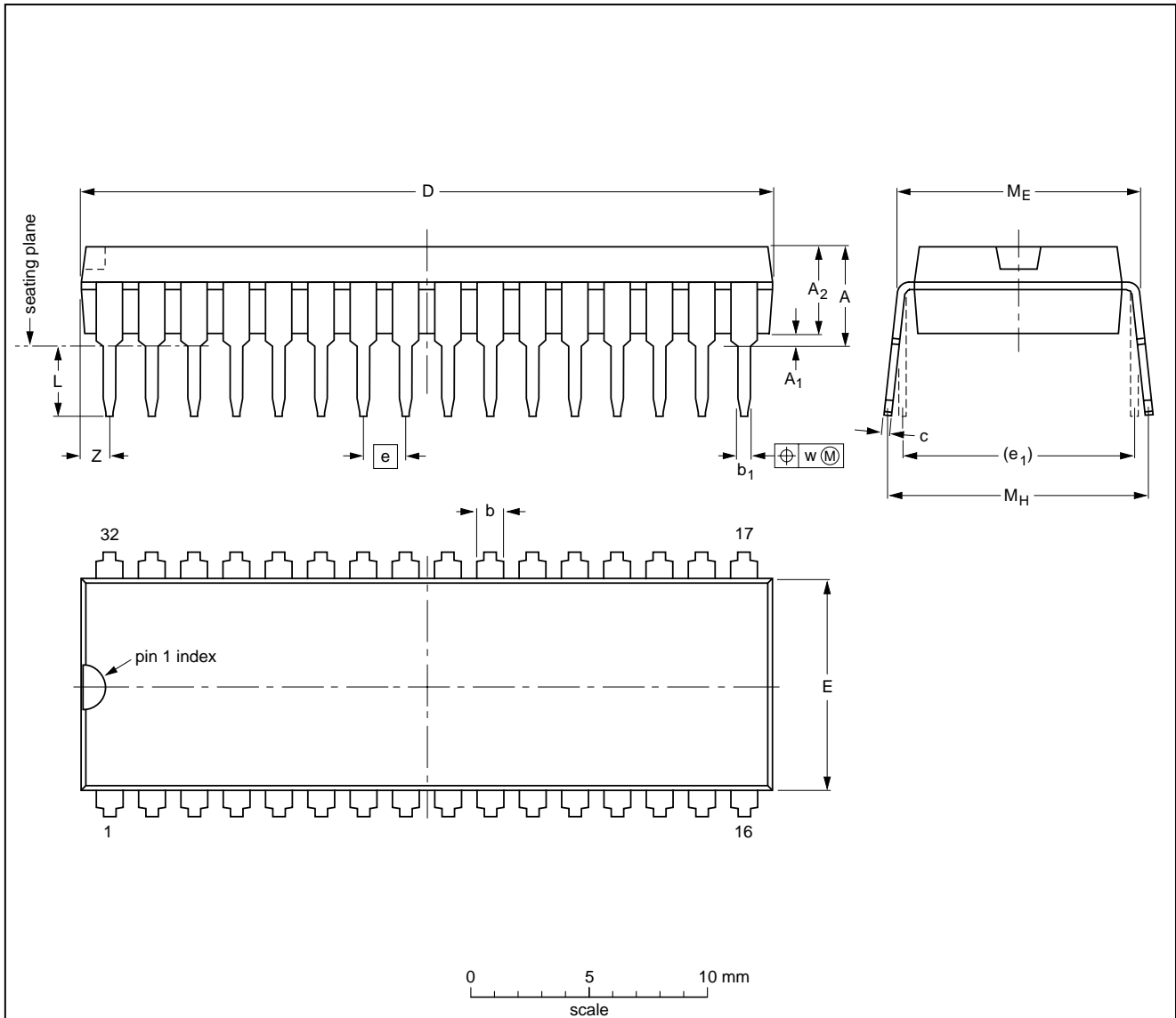

DIMENSIONS (mm are the original dimensions)

UNIT	A max.	A ₁ min.	A ₂ max.	b	b ₁	c	D ⁽¹⁾	E ⁽¹⁾	e	e ₁	L	M _E	M _H	w	Z ⁽¹⁾ max.
mm	4.7	0.51	3.8	1.3 0.8	0.53 0.40	0.32 0.23	29.4 28.5	9.1 8.7	1.778	10.16	3.2 2.8	10.7 10.2	12.2 10.5	0.18	1.6

Note

1. Plastic or metal protrusions of 0.25 mm maximum per side are not included.

OUTLINE VERSION	REFERENCES				EUROPEAN PROJECTION	ISSUE DATE
	IEC	JEDEC	EIAJ			
SOT232-1						92-11-17 95-02-04

Sound fader control circuit

TEA6320

SO32: plastic small outline package; 32 leads; body width 7.5 mm

SOT287-1

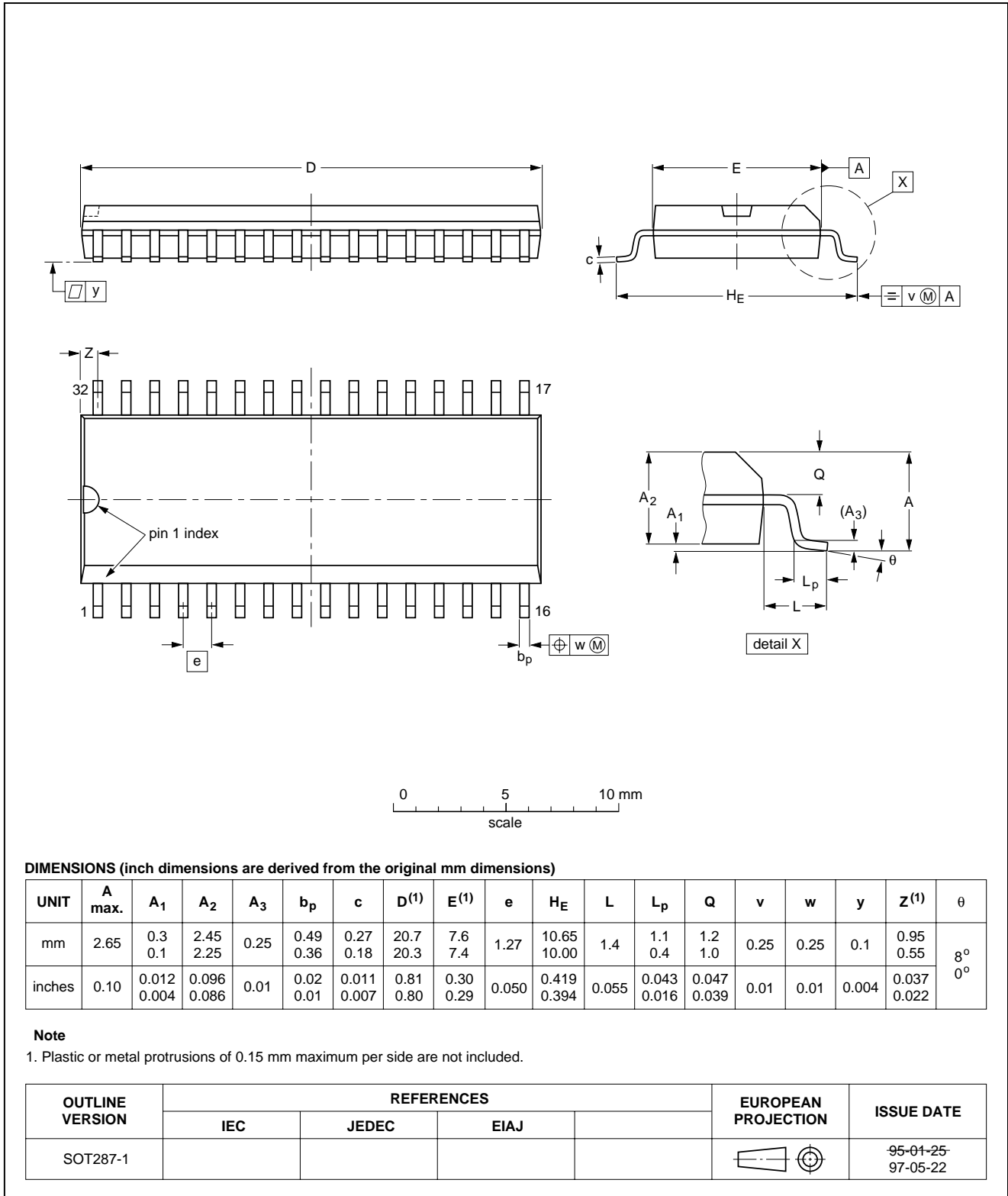

Sound fader control circuit

TEA6320

SOLDERING

Introduction

There is no soldering method that is ideal for all IC packages. Wave soldering is often preferred when through-hole and surface mounted components are mixed on one printed-circuit board. However, wave soldering is not always suitable for surface mounted ICs, or for printed-circuits with high population densities. In these situations reflow soldering is often used.

This text gives a very brief insight to a complex technology. A more in-depth account of soldering ICs can be found in our *"IC Package Databook"* (order code 9398 652 90011).

SDIP

SOLDERING BY DIPPING OR BY WAVE

The maximum permissible temperature of the solder is 260 °C; solder at this temperature must not be in contact with the joint for more than 5 seconds. The total contact time of successive solder waves must not exceed 5 seconds.

The device may be mounted up to the seating plane, but the temperature of the plastic body must not exceed the specified maximum storage temperature ($T_{stg\ max}$). If the printed-circuit board has been pre-heated, forced cooling may be necessary immediately after soldering to keep the temperature within the permissible limit.

REPAIRING SOLDERED JOINTS

Apply a low voltage soldering iron (less than 24 V) to the lead(s) of the package, below the seating plane or not more than 2 mm above it. If the temperature of the soldering iron bit is less than 300 °C it may remain in contact for up to 10 seconds. If the bit temperature is between 300 and 400 °C, contact may be up to 5 seconds.

SO

REFLOW SOLDERING

Reflow soldering techniques are suitable for all SO packages.

Reflow soldering requires solder paste (a suspension of fine solder particles, flux and binding agent) to be applied to the printed-circuit board by screen printing, stencilling or pressure-syringe dispensing before package placement.

Several techniques exist for reflowing; for example, thermal conduction by heated belt. Dwell times vary between 50 and 300 seconds depending on heating method. Typical reflow temperatures range from 215 to 250 °C.

Preheating is necessary to dry the paste and evaporate the binding agent. Preheating duration: 45 minutes at 45 °C.

WAVE SOLDERING

Wave soldering techniques can be used for all SO packages if the following conditions are observed:

- A double-wave (a turbulent wave with high upward pressure followed by a smooth laminar wave) soldering technique should be used.
- The longitudinal axis of the package footprint must be parallel to the solder flow.
- The package footprint must incorporate solder thieves at the downstream end.

During placement and before soldering, the package must be fixed with a droplet of adhesive. The adhesive can be applied by screen printing, pin transfer or syringe dispensing. The package can be soldered after the adhesive is cured.

Maximum permissible solder temperature is 260 °C, and maximum duration of package immersion in solder is 10 seconds, if cooled to less than 150 °C within 6 seconds. Typical dwell time is 4 seconds at 250 °C.

A mildly-activated flux will eliminate the need for removal of corrosive residues in most applications.

REPAIRING SOLDERED JOINTS

Fix the component by first soldering two diagonally-opposite end leads. Use only a low voltage soldering iron (less than 24 V) applied to the flat part of the lead. Contact time must be limited to 10 seconds at up to 300 °C. When using a dedicated tool, all other leads can be soldered in one operation within 2 to 5 seconds between 270 and 320 °C.

Sound fader control circuit

TEA6320

DEFINITIONS

Data sheet status	
Objective specification	This data sheet contains target or goal specifications for product development.
Preliminary specification	This data sheet contains preliminary data; supplementary data may be published later.
Product specification	This data sheet contains final product specifications.
Limiting values	
Limiting values given are in accordance with the Absolute Maximum Rating System (IEC 134). Stress above one or more of the limiting values may cause permanent damage to the device. These are stress ratings only and operation of the device at these or at any other conditions above those given in the Characteristics sections of the specification is not implied. Exposure to limiting values for extended periods may affect device reliability.	
Application information	
Where application information is given, it is advisory and does not form part of the specification.	

LIFE SUPPORT APPLICATIONS

These products are not designed for use in life support appliances, devices, or systems where malfunction of these products can reasonably be expected to result in personal injury. Philips customers using or selling these products for use in such applications do so at their own risk and agree to fully indemnify Philips for any damages resulting from such improper use or sale.

PURCHASE OF PHILIPS I²C COMPONENTS

Purchase of Philips I²C components conveys a license under the Philips' I²C patent to use the components in the I²C system provided the system conforms to the I²C specification defined by Philips. This specification can be ordered using the code 9398 393 40011.

Sound fader control circuit

TEA6320

NOTES

Sound fader control circuit

TEA6320

NOTES

Sound fader control circuit

TEA6320

NOTES

Philips Semiconductors – a worldwide company

Argentina: IEROD, Av. Juramento 1992 - 14.b, (1428)
BUENOS AIRES, Tel. (541)786 7633, Fax. (541)786 9367

Australia: 34 Waterloo Road, NORTH RYDE, NSW 2113,
Tel. (02)805 4455, Fax. (02)805 4466

Austria: Triester Str. 64, A-1101 WIEN, P.O. Box 213,
Tel. (01)60 101-1236, Fax. (01)60 101-1211

Belgium: Postbus 90050, 5600 PB EINDHOVEN, The Netherlands,
Tel. (31)40-2783749, Fax. (31)40-2788399

Brazil: Rua do Rocio 220 - 5th floor, Suite 51,
CEP: 04552-903-SÃO PAULO-SP, Brazil,
P.O. Box 7383 (01064-970),
Tel. (011)821-2333, Fax. (011)829-1849

Canada: PHILIPS SEMICONDUCTORS/COMPONENTS:
Tel. (800) 234-7381, Fax. (708) 296-8556

Chile: Av. Santa Maria 0760, SANTIAGO,
Tel. (02)773 816, Fax. (02)777 6730

China/Hong Kong: 501 Hong Kong Industrial Technology Centre,
72 Tat Chee Avenue, Kowloon Tong, HONG KONG,
Tel. (852)2319 7888, Fax. (852)2319 7700

Colombia: IPRELENZO LTDA, Carrera 21 No. 56-17,
77621 BOGOTA, Tel. (571)249 7624/(571)217 4609,
Fax. (571)217 4549

Denmark: Prags Boulevard 80, PB 1919, DK-2300
COPENHAGEN S, Tel. (45)32 88 26 36, Fax. (45)31 57 19 49

Finland: Sinikalliontie 3, FIN-02630 ESPOO,
Tel. (358)0-615 800, Fax. (358)0-61580 920

France: 4 Rue du Port-aux-Vins, BP317,
92156 SURESNES Cedex,
Tel. (01)4099 6161, Fax. (01)4099 6427

Germany: P.O. Box 10 51 40, 20035 HAMBURG,
Tel. (040)23 53 60, Fax. (040)23 53 63 00

Greece: No. 15, 25th March Street, GR 17778 TAVROS,
Tel. (01)4894 339/4894 911, Fax. (01)4814 240

India: Philips INDIA Ltd, Shivsagar Estate, A Block,
Dr. Annie Besant Rd. Worli, Bombay 400 018
Tel. (022)4938 541, Fax. (022)4938 722

Indonesia: Philips House, Jalan H.R. Rasuna Said Kav. 3-4,
P.O. Box 4252, JAKARTA 12950,
Tel. (021)5201 122, Fax. (021)5205 189

Ireland: Newstead, Clonskeagh, DUBLIN 14,
Tel. (01)7640 000, Fax. (01)7640 200

Italy: PHILIPS SEMICONDUCTORS S.r.l.,
Piazza IV Novembre 3, 20124 MILANO,
Tel. (0039)2 6752 2531, Fax. (0039)2 6752 2557

Japan: Philips Bldg 13-37, Kohnan2-chome, Minato-ku, TOKYO 108,
Tel. (03)3740 5130, Fax. (03)3740 5077

Korea: Philips House, 260-199 Itaewon-dong,
Yongsan-ku, SEOUL, Tel. (02)709-1412, Fax. (02)709-1415

Malaysia: No. 76 Jalan Universiti, 46200 PETALING JAYA,
SELANGOR, Tel. (03)750 5214, Fax. (03)757 4880

Mexico: 5900 Gateway East, Suite 200, EL PASO, TX 79905,
Tel. 9-5(800)234-7381, Fax. (708)296-8556

Netherlands: Postbus 90050, 5600 PB EINDHOVEN, Bldg. VB,
Tel. (040)2783749, Fax. (040)2788399

New Zealand: 2 Wagener Place, C.P.O. Box 1041, AUCKLAND,
Tel. (09)849-4160, Fax. (09)849-7811

Norway: Box 1, Manglerud 0612, OSLO,
Tel. (022)74 8000, Fax. (022)74 8341

Pakistan: Philips Electrical Industries of Pakistan Ltd.,
Exchange Bldg. ST-2/A, Block 9, KDA Scheme 5, Clifton,
KARACHI 75600, Tel. (021)587 4641-49,
Fax. (021)577035/5874546

Philippines: PHILIPS SEMICONDUCTORS PHILIPPINES Inc.,
106 Valero St. Salcedo Village, P.O. Box 2108 MCC, MAKATI,
Metro MANILA, Tel. (63) 2 816 6380, Fax. (63) 2 817 3474

Portugal: PHILIPS PORTUGUESA, S.A.,
Rua dr. António Loureiro Borges 5, Arquiparque - Miraflores,
Apartado 300, 2795 LINDA-A-VELHA,
Tel. (01)4163160/4163333, Fax. (01)4163174/4163366

Singapore: Lorong 1, Toa Payoh, SINGAPORE 1231,
Tel. (65)350 2000, Fax. (65)251 6500

South Africa: S.A. PHILIPS Pty Ltd.,
195-215 Main Road Martindale, 2092 JOHANNESBURG,
P.O. Box 7430, Johannesburg 2000,
Tel. (011)470-5911, Fax. (011)470-5494

Spain: Balmes 22, 08007 BARCELONA,
Tel. (03)301 6312, Fax. (03)301 42 43

Sweden: Kottbygatan 7, Akalla. S-164 85 STOCKHOLM,
Tel. (0)8-632 2000, Fax. (0)8-632 2745

Switzerland: Allmendstrasse 140, CH-8027 ZÜRICH,
Tel. (01)488 2211, Fax. (01)481 77 30

Taiwan: PHILIPS TAIWAN Ltd., 23-30F, 66, Chung Hsiao West
Road, Sec. 1. Taipeh, Taiwan ROC, P.O. Box 22978,
TAIPEI 100, Tel. (886) 2 382 4443, Fax. (886) 2 382 4444

Thailand: PHILIPS ELECTRONICS (THAILAND) Ltd.,
209/2 Sanpavuth-Bangna Road Prakanong,
Bangkok 10260, THAILAND,
Tel. (66) 2 745-4090, Fax. (66) 2 398-0793

Turkey: Talatpasa Cad. No. 5, 80640 GÜLTEPE/ISTANBUL,
Tel. (0212)279 27 70, Fax. (0212)282 67 07

Ukraine: Philips UKRAINE, 2A Akademika Koroleva str., Office 165,
252148 KIEV, Tel. 380-44-4760297, Fax. 380-44-4766991

United Kingdom: Philips Semiconductors LTD.,
276 Bath Road, Hayes, MIDDLESEX UB3 5BX,
Tel. (0181)730-5000, Fax. (0181)754-8421

United States: 811 East Arques Avenue, SUNNYVALE,
CA 94088-3409, Tel. (800)234-7381, Fax. (708)296-8556

Uruguay: Coronel Mora 433, MONTEVIDEO,
Tel. (02)70-4044, Fax. (02)92 0601

Internet: <http://www.semiconductors.philips.com/ps/>

For all other countries apply to: Philips Semiconductors,
International Marketing and Sales, Building BE-p,
P.O. Box 218, 5600 MD EINDHOVEN, The Netherlands,
Telex 35000 phtcnl, Fax. +31-40-2724825

SCDS47

© Philips Electronics N.V. 1995

All rights are reserved. Reproduction in whole or in part is prohibited without the prior written consent of the copyright owner.

The information presented in this document does not form part of any quotation or contract, is believed to be accurate and reliable and may be changed without notice. No liability will be accepted by the publisher for any consequence of its use. Publication thereof does not convey nor imply any license under patent- or other industrial or intellectual property rights.

Printed in The Netherlands

513061/1100/02/pp40
Document order number:

Date of release: 1995 Dec 19
9397 750 00533