

# DATA SHEET

## **TEA5581** **TEA5581T** PLL stereo decoder

Product specification  
File under Integrated Circuits, IC01

June 1989

---

**PLL stereo decoder****TEA5581  
TEA5581T**

---

**GENERAL DESCRIPTION**

The TEA5581 PLL stereo decoder is for car and medium-fi radios. It incorporates all the features provided by the TEA5580 together with a source selector, muting circuit and output amplifiers with adjustable gain. It also features a switch for radio or cassette function and a 228 kHz voltage-controlled oscillator (VCO) that is locked to the 19 kHz stereo pilot tone by a phase-locked loop (PLL) system. Subcarrier frequencies of 19, 38, 57 and 114 kHz are regenerated via I<sup>2</sup>L logic from the VCO output.

The PLL phase detector suppresses phase distortion due to the 57 kHz pilot tone from the German 'Verkehrs Warnfunk' (VWF) traffic warning system. Typical suppression of the 19 kHz stereo pilot tone is 40 dB. Adjacent channel interference is prevented by the use of two demodulators, one driven by the 38 kHz decoding signal and the other at 114 kHz to suppress the third harmonic of the multiplexed input signal.

The gain of the input amplifier can be adjusted by an external resistor and the circuit includes compensation for an IF filter typical roll-off frequency of 50 kHz (2 dB down at 38 kHz).

The supply voltage range of the circuit is 7 V to 16 V.

**Features**

- Wide supply voltage range
- Automatic mono/stereo switching (pilot presence detector)
- Smooth stereo-to-mono change-over at weak signals (signal-dependent stereo channel separation)
- LED driver for stereo/mono indicator
- Suppresses:
  - third harmonics (114 kHz) of multiplexed signal to prevent interference from strong adjacent channels;
  - phase distortion due to the 57 kHz signal from VWF transmitters
- Pilot cancelling circuit to give added suppression of 19 kHz stereo pilot tone (up to 25 dB)
- IF filter roll-off compensation
- Source selector for radio or cassette input (typ. 90 dB)
- Mute circuit for 90 dB (typ.) muting of the output level
- Matrix and two output buffers with adjustable gain (max. 20 dB).

**PACKAGE OUTLINES**

TEA5581 : 16-lead DIL; plastic (SOT38); SOT38-1; 1996 August 16.

TEA5581T: 16-lead mini-pack; plastic (SO16L; SOT162A); SOT162-1; 1996 August 16.

PLL stereo decoder

TEA5581  
TEA5581T

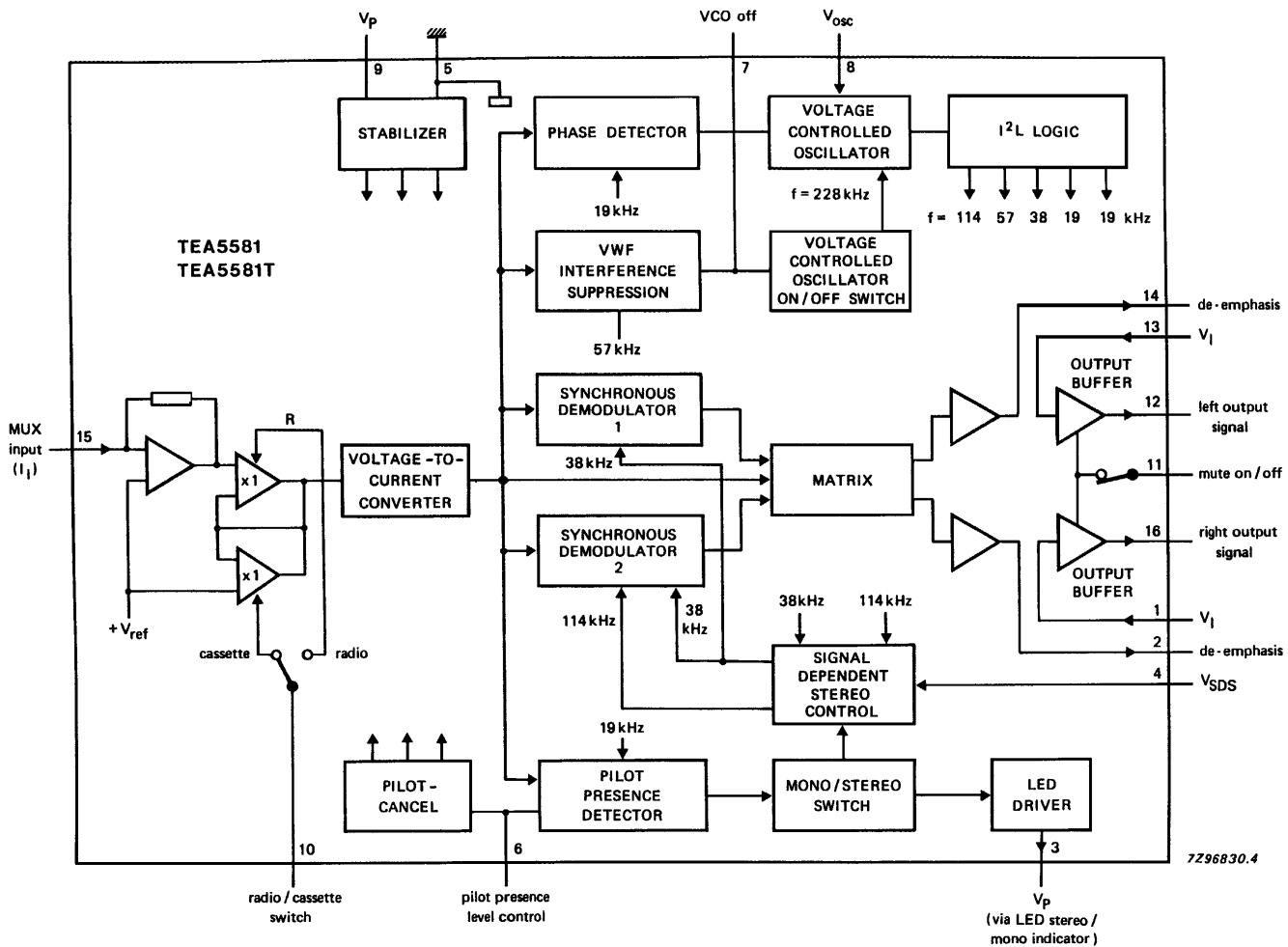

Fig.1 Block diagram.

PLL stereo decoder

TEA5581  
TEA5581T

**RATINGS**

Limiting values in accordance with the Absolute Maximum System (IEC 134)

PARAMETER	CONDITIONS	SYMBOL	MIN.	MAX.	UNIT
Supply voltage range		$V_{3-5}, V_{9-5}$	-	18	V
LED-driver current (peak value)		$-I_{3M}$	-	75	mA
Total power dissipation		$P_{tot}$	see derating curve Fig.2		
Storage temperature range		$T_{stg}$	-65	+150	°C
Operating ambient temperature range		$T_{amb}$	-30	+80	°C
Electrostatic handling*		$V_{es}$		+600	V

From junction to ambient in free air

SOT38

$R_{th\ j-a}$  75 K/W

SOT162

$R_{th\ j-a}$  95 K/W

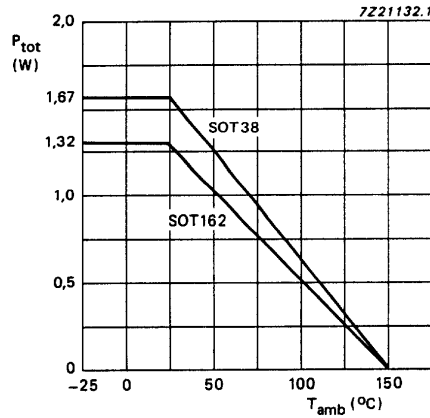

Fig.2 Power derating curve.

\* Equivalent to discharging a 100 pF capacitor through a 1.5 kΩ resistor.

## PLL stereo decoder

TEA5581  
TEA5581T**DC CHARACTERISTICS**

Measured in the circuit of Fig.7;  $V = 8.5 \text{ V}$ ;  $T_{\text{amb}} = 25 \text{ }^\circ\text{C}$ ; all DC voltages are with respect to pin 5; all currents are positive into the IC.

PARAMETER	CONDITIONS	SYMBOL	MIN.	TYP.	MAX.	UNIT
Supply voltage	$R1 = 75 \Omega$	$V_S$	7.0	8.5	18	V
Total current consumption	without LED driver	$I_{\text{tot}}$	–	15	20	mA
Power dissipation		$P_{\text{tot}}$	–	125	–	mW
Voltage						
pin 15		$V_{15}$	–	2.1	–	V
pins 12 and 16		$V_{12}, V_{16}$	3.2	3.6	4.0	V
DC output current						
pins 2 and 14		$-I_{14}, -I_2$	225	320	450	$\mu\text{A}$
Output current						
pin 3		$-I_3$	–	–	20	mA
Switch "VCO-OFF" voltage		$V_7$	–	2.2	–	V
Switch "VCO-OFF" current		$I_7$	–	50	75	$\mu\text{A}$

## PLL stereo decoder

TEA5581  
TEA5581T**AC CHARACTERISTICS**

Measured in the circuit of Fig.7;  $V_S = 8.5$  V;  $T_{amb} = 25$  °C; AC measurements have an input MUX-signal of 1 V (peak-to-peak);  $V_{pilot} = 32$  mV (9%);  $f_m = 1$  kHz; oscillator adjusted to 228 kHz at  $V_i = 0$  V; values are measured with an external roll-off network of 50 kHz (2 dB down at 38 kHz) at the input (dashed components  $R_S$  and  $C_S$  in Fig.7); unless otherwise specified

PARAMETER	CONDITIONS	SYMBOL	MIN.	TYP.	MAX.	UNIT
Transimpedance		$V_O/I_I$	0.13	0.15	0.17	V/ $\mu$ A
Input current (RMS value)		$I_{I(rms)}$	–	–	12	$\mu$ A
Overall gain	mono; $R_3 = 47$ k $\Omega$	$G_O(V_O/V_i)$	9.0	10.0	11.0	dB
AF output voltage (RMS value)		$V_{12} = V_{16}$	0.95	1.14	1.33	V
AF output voltage (RMS value)		$V_2 = V_{14}$	–	–	500	mV
Total harmonic distortion	note 1; $V_{O(rms)} = 1$ V	THD	–	0.1	0.5	%
Output voltage	THD = 1%	$V_{12} = V_{16}$	–	1.5	–	V
Output channel unbalanced		$V_{12} = V_{16}$	–	0.2	1.0	dB
Channel separation	IF roll-off frequency = 50 kHz $L = 1$ ; $R = 0$	$\alpha$	26	40	–	dB
S/N ratio	bandwidth 20 Hz to 16 kHz bandwidth IEC 79 (curve Din A)	S/N	–	76	–	dB
	(curve Din A)	S/N	–	82	–	dB
<b>SDS control</b>	see Fig.6					
Channel separation	$V_4 = 1.0$ V	$\alpha$	5	10	15	dB
Full stereo	channel separation $\geq 26$ dB	$V_4$	–	1.2	1.25	V
Full mono	channel separation $\leq 1$ dB	$V_4$	0.75	0.8	–	V
<b>Stereo/mono switch</b>	note 2; see Fig.5; $R_4 = 180$ k $\Omega$					
Switching to:						
stereo		$V_{pilot}$	–	14	20	mV
mono		$V_{pilot}$	4	–	–	mV
Hysteresis		$\Delta V_I$	–	4.5	–	mV

## PLL stereo decoder

TEA5581  
TEA5581T

PARAMETER	CONDITIONS	SYMBOL	MIN.	TYP.	MAX.	UNIT
<b>Carrier and harmonic suppression at the output</b>	note 3					
Pilot signal suppression	f = 19 kHz; R4 = 180 k $\Omega$ ; note 2; see Figs 3 and 4	$\alpha_{19}$	32	40	–	dB
Subcarrier suppression						
f = 38 kHz		$\alpha_{38}$	–	50	–	dB
f = 57 kHz		$\alpha_{57}$	–	50	–	dB
f = 228 kHz		$\alpha_{228}$	–	75	–	dB
Intermodulation suppression	note 4					
f <sub>m</sub> = 10 kHz	spurious signal f <sub>s</sub> = 1 kHz	$\alpha_2$	–	50	–	dB
f <sub>m</sub> = 13 kHz	spurious signal f <sub>s</sub> = 1 kHz	$\alpha_3$	–	50	–	dB
VWF tone suppression						
f = 57 kHz	note 5	$\alpha_{57}$	–	80	–	dB
SCA tone rejection						
f = 67 kHz	note 6	$\alpha_{67}$	–	70	–	dB
ACI rejection	note 7					
f = 114 kHz		$\alpha_{114}$	–	90	–	dB
f = 190 kHz		$\alpha_{190}$	–	60	–	dB
<b>Ripple rejection</b>						
Ripple rejection	f = 100 Hz; V <sub>ripple</sub> = 100 mV; mono	RR <sub>100</sub>	–	50	–	dB
<b>VCO</b>						
Oscillator frequency						
adjustable with R5		f <sub>osc</sub>	–	228	–	kHz
Capture range	deviation from 228 kHz centre frequency; V <sub>pilot</sub> = 32 mV	$\Delta f/f$	–	6	–	%
Temperature coefficient	uncompensated	TC	–	–200 × 10 <sup>–6</sup>	–	K <sup>–1</sup>

## PLL stereo decoder

TEA5581  
TEA5581T

PARAMETER	CONDITIONS	SYMBOL	MIN.	TYP.	MAX.	UNIT
<b>Source selector</b>						
Suppression of MPX signal	$V_{10} \geq 2 \text{ V}$	$\alpha$	80	90	–	dB
Switching level voltage	cassette to radio	$V_{IL}$	–	–	0.8	V
current		$I_{IL}$	–	10	25	$\mu\text{A}$
<b>Output amplifiers</b>						
Gain	note 8; $R_6/R_7$	$G_v$	–	–	20	dB
Output impedance		$Z_o$	–	200	500	$\Omega$
External load impedance		$ Z_l $	5	–	–	$\text{k}\Omega$
Suppression (mute)	$V_{11} = \leq 0,8 \text{ V}$	$\alpha$	84	90	–	dB
<b>DC offset</b>						
voltage at outputs during mute switching	mute OFF-to-ON	$\Delta V_{12}, \Delta V_{16}$	–	1.0	–	mV
	mute ON-to-OFF	$\Delta V_{12}, \Delta V_{16}$	–	2.0	–	mV
<b>Muting circuit</b>						
Input voltage	mute ON	$V_{IL}$	–	–	0.8	V
	mute OFF	$V_{IH}$	2.0	–	$V_s$	V
Input current	mute ON	$I_{IL}$	–	10	25	$\mu\text{A}$
	mute OFF	$I_{IH}$	–	–	1	$\mu\text{A}$

## PLL stereo decoder

TEA5581  
TEA5581T**Notes to the characteristics**

1. Guaranteed for mono, mono + pilot and stereo.
2. Also adjustable.
3. Reference output voltage at 1 kHz (measured channel R, pin 16).
4. Intermodulation suppression (Beat-Frequency Components):

$$\alpha_2 = \frac{V_{o(\text{signal})}(\text{at } 1 \text{ kHz})}{V_{o(\text{spurious})}(\text{at } 1 \text{ kHz})}; f_s = (2 \times 10 \text{ kHz}) - 19 \text{ kHz}$$

$$\alpha_3 = \frac{V_{o(\text{signal})}(\text{at } 1 \text{ kHz})}{V_{o(\text{spurious})}(\text{at } 1 \text{ kHz})}; f_s = (3 \times 13 \text{ kHz}) - 38 \text{ kHz}$$

measured with 91% mono signal;  $f_m = 10$  or  $13$  kHz; 9% pilot signal.

5. Traffic radio (VWF) tone suppression:

$$\alpha_{57} = \frac{V_{o(\text{signal})}(\text{at } 1 \text{ kHz})}{V_{o(\text{spurious})}(\text{at } 1 \text{ kHz} \pm 23 \text{ Hz})}$$

measured with 91% stereo signal;  $f_m = 1$  kHz; 9% pilot signal; 5% traffic subcarrier ( $f = 57$  kHz; 60% AM modulated with  $f_{\text{mod}} = 23$  Hz).

6. SCA (Subsidiary Communication Authorization) tone rejection:

$$\alpha_{67} = \frac{V_{o(\text{signal})}(\text{at } 1 \text{ kHz})}{V_{o(\text{spurious})}(\text{at } 9 \text{ kHz})}; f_s = (2 \times 38 \text{ kHz}) - 67 \text{ kHz}$$

measured with 81% mono signal;  $f_m = 1$  kHz; 9% pilot signal; 10% SCA-subcarrier ( $f_s = 67$  kHz, unmodulated).

7. ACI (Adjacent Channel Interference) rejection at:

$$\alpha_{114} = \frac{V_{o(\text{signal})}(\text{at } 1 \text{ kHz})}{V_{o(\text{spurious})}(\text{at } 4 \text{ kHz})}; f_s = (3 \times 38 \text{ kHz}) - 110 \text{ kHz}$$

$$\alpha_{190} = \frac{V_{o(\text{signal})}(\text{at } 1 \text{ kHz})}{V_{o(\text{spurious})}(\text{at } 4 \text{ kHz})}; f_s = (5 \times 38 \text{ kHz}) - 186 \text{ kHz}$$

measured with 90% mono signal;  $f_s = 1$  kHz; 9% pilot signal; 1% spurious signal ( $f_s = 110$  or  $186$  kHz, unmodulated).

8. Maximum permitted value of feedback resistor = 220 k $\Omega$ .

PLL stereo decoder

TEA5581  
TEA5581T

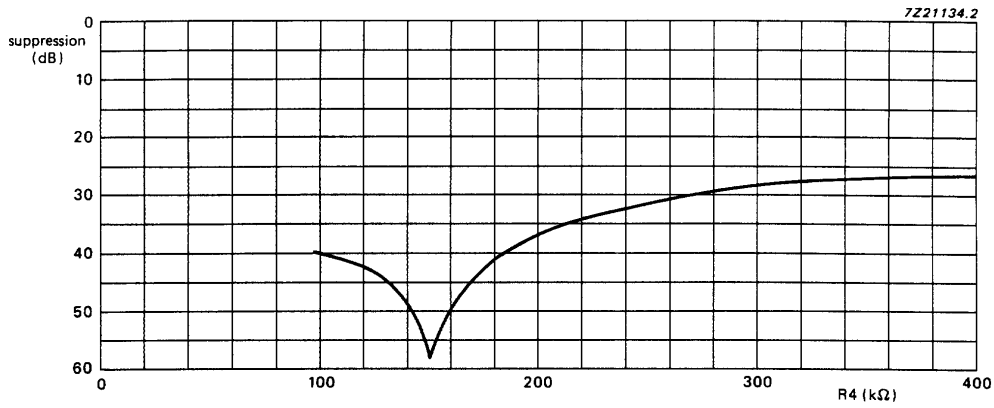
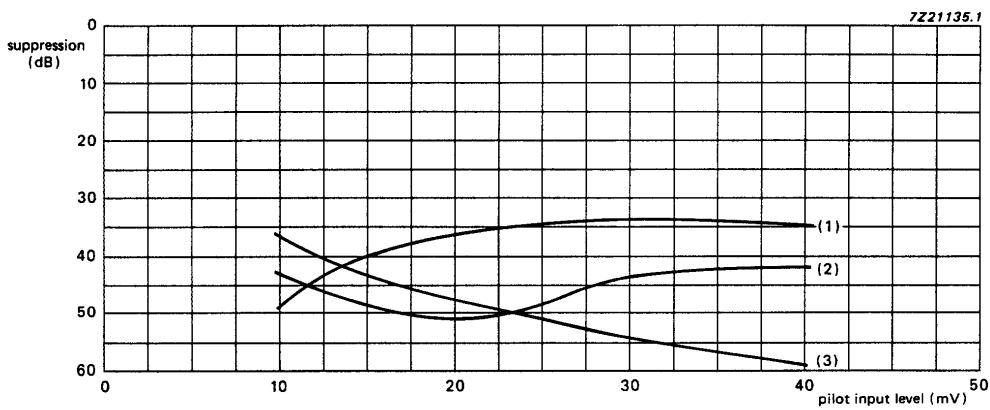

Fig.3 Pilot suppression plotted against resistance (R4).



- (1) 220 kΩ
- (2) 180 kΩ
- (3) 150 kΩ

Fig.4 Pilot suppression plotted against pilot input voltage level.

PLL stereo decoder

TEA5581  
TEA5581T

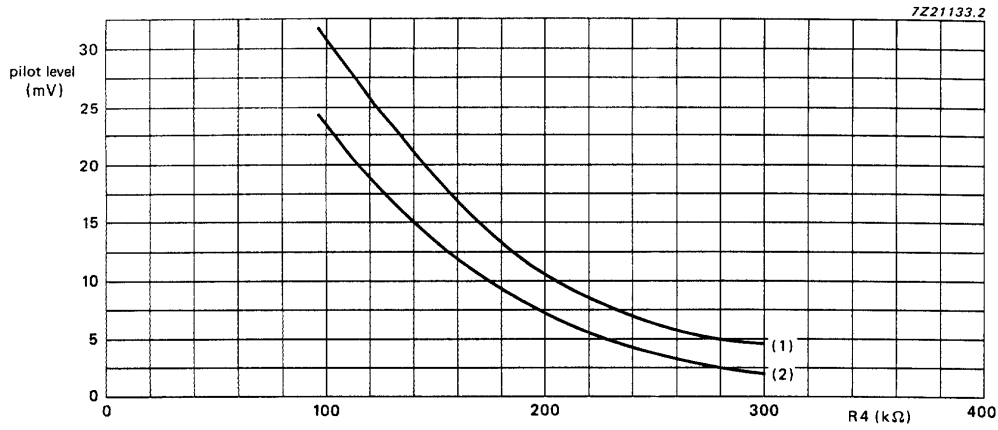

- (1) Switching from mono to stereo.
- (2) Switching from stereo to mono.

Fig.5 Pilot sensitivity against resistance (R4).

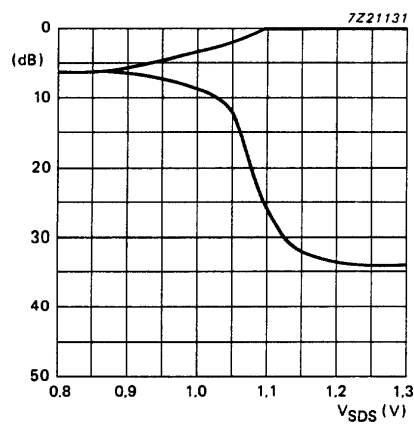
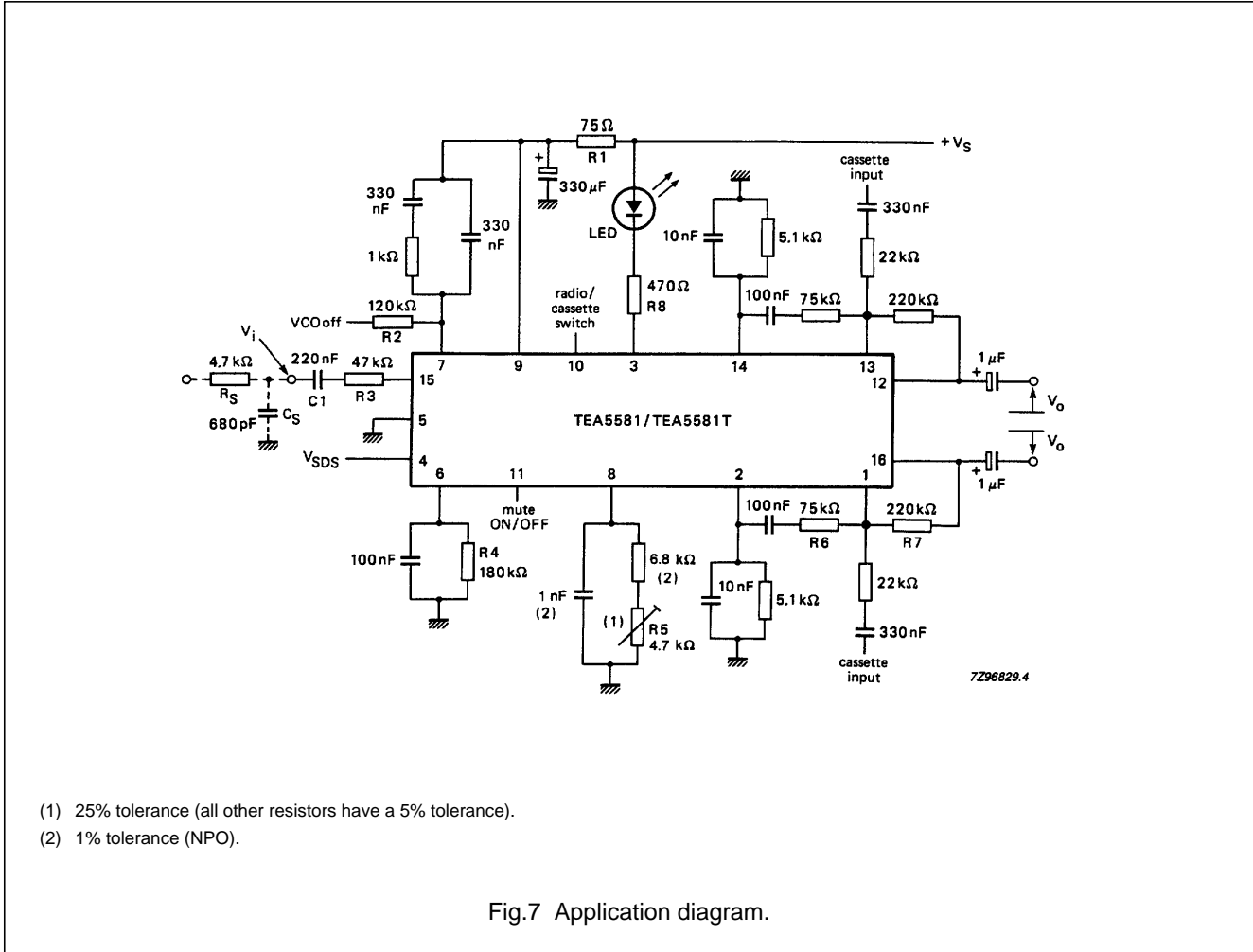

Fig.6 Channel separation against VSDS.

PLL stereo decoder

TEA5581  
TEA5581T

APPLICATION INFORMATION



PLL stereo decoder

TEA5581  
TEA5581T

PACKAGE OUTLINE

DIP16: plastic dual in-line package; 16 leads (300 mil); long body

SOT38-1

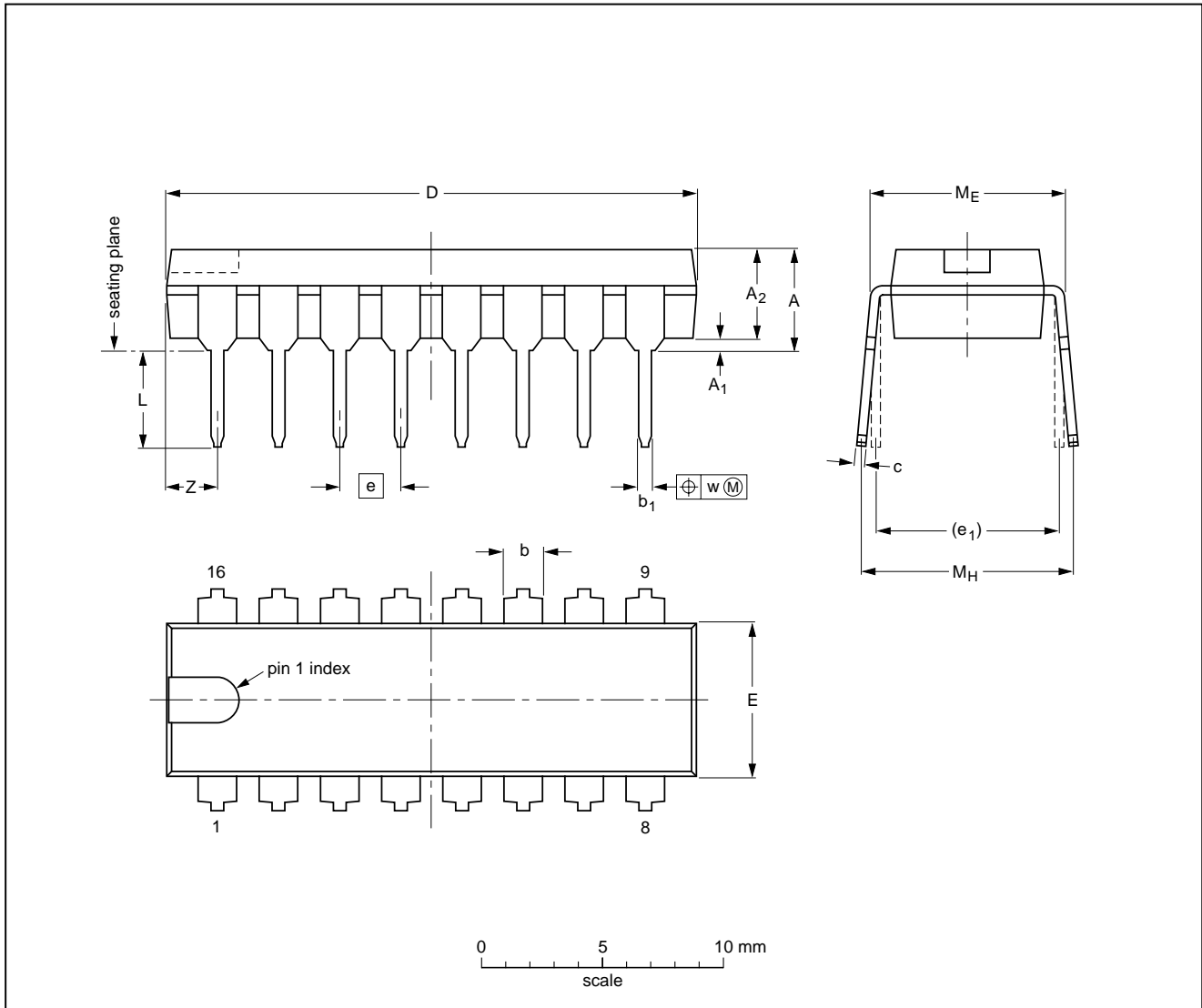

DIMENSIONS (inch dimensions are derived from the original mm dimensions)

UNIT	A max.	A <sub>1</sub> min.	A <sub>2</sub> max.	b	b <sub>1</sub>	c	D <sup>(1)</sup>	E <sup>(1)</sup>	e	e <sub>1</sub>	L	M <sub>E</sub>	M <sub>H</sub>	w	Z <sup>(1)</sup> max.
mm	4.7	0.51	3.7	1.40 1.14	0.53 0.38	0.32 0.23	21.8 21.4	6.48 6.20	2.54	7.62	3.9 3.4	8.25 7.80	9.5 8.3	0.254	2.2
inches	0.19	0.020	0.15	0.055 0.045	0.021 0.015	0.013 0.009	0.86 0.84	0.26 0.24	0.10	0.30	0.15 0.13	0.32 0.31	0.37 0.33	0.01	0.087

Note

1. Plastic or metal protrusions of 0.25 mm maximum per side are not included.

OUTLINE VERSION	REFERENCES				EUROPEAN PROJECTION	ISSUE DATE
	IEC	JEDEC	EIAJ			
SOT38-1	050G09	MO-001AE				92-10-02 95-01-19

PLL stereo decoder

TEA5581  
TEA5581T

SO16: plastic small outline package; 16 leads; body width 7.5 mm

SOT162-1

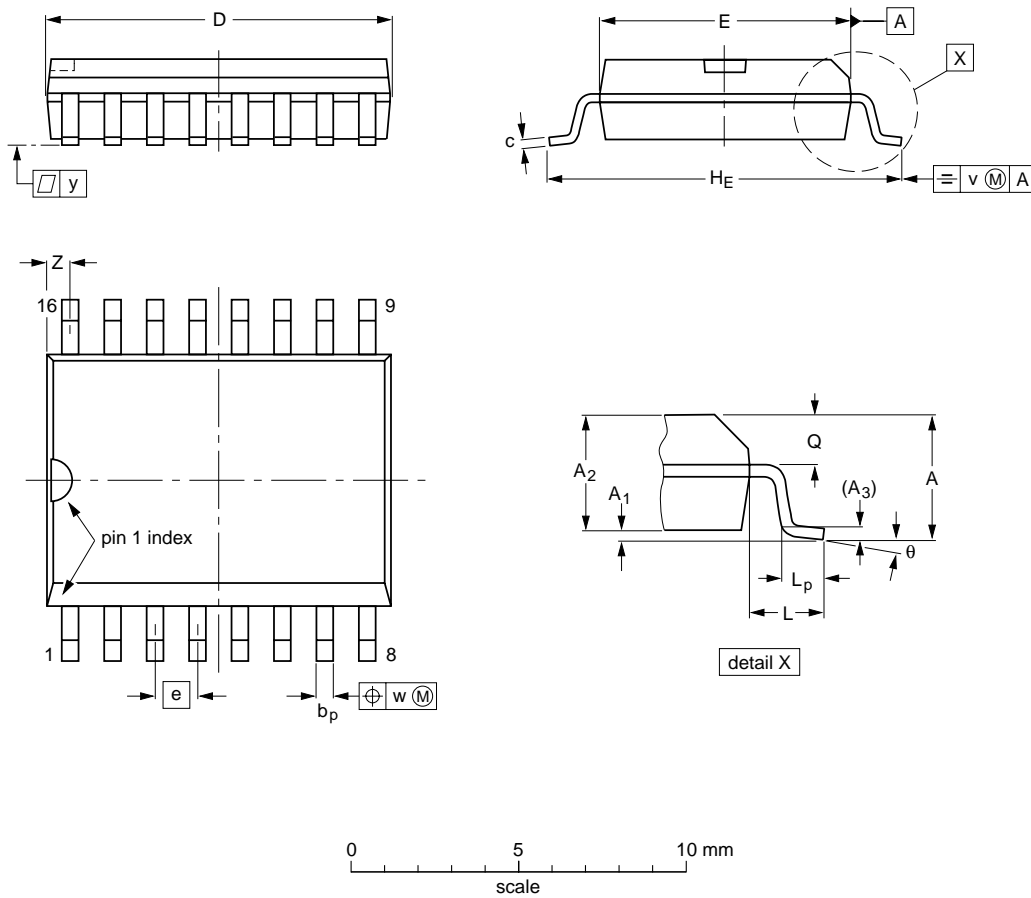

**DIMENSIONS (inch dimensions are derived from the original mm dimensions)**

UNIT	A max.	A <sub>1</sub>	A <sub>2</sub>	A <sub>3</sub>	b <sub>p</sub>	c	D <sup>(1)</sup>	E <sup>(1)</sup>	e	H <sub>E</sub>	L	L <sub>p</sub>	Q	v	w	y	Z <sup>(1)</sup>	θ
mm	2.65	0.30 0.10	2.45 2.25	0.25	0.49 0.36	0.32 0.23	10.5 10.1	7.6 7.4	1.27	10.65 10.00	1.4	1.1 0.4	1.1 1.0	0.25	0.25	0.1	0.9 0.4	8° 0°
inches	0.10	0.012 0.004	0.096 0.089	0.01	0.019 0.014	0.013 0.009	0.41 0.40	0.30 0.29	0.050	0.419 0.394	0.055	0.043 0.016	0.043 0.039	0.01	0.01	0.004	0.035 0.016	

**Note**

1. Plastic or metal protrusions of 0.15 mm maximum per side are not included.

OUTLINE VERSION	REFERENCES				EUROPEAN PROJECTION	ISSUE DATE
	IEC	JEDEC	EIAJ			
SOT162-1	075E03	MS-013AA				95-01-24 97-05-22

## PLL stereo decoder

TEA5581  
TEA5581T

### SOLDERING

#### Introduction

There is no soldering method that is ideal for all IC packages. Wave soldering is often preferred when through-hole and surface mounted components are mixed on one printed-circuit board. However, wave soldering is not always suitable for surface mounted ICs, or for printed-circuits with high population densities. In these situations reflow soldering is often used.

This text gives a very brief insight to a complex technology. A more in-depth account of soldering ICs can be found in our *"IC Package Databook"* (order code 9398 652 90011).

#### DIP

##### SOLDERING BY DIPPING OR BY WAVE

The maximum permissible temperature of the solder is 260 °C; solder at this temperature must not be in contact with the joint for more than 5 seconds. The total contact time of successive solder waves must not exceed 5 seconds.

The device may be mounted up to the seating plane, but the temperature of the plastic body must not exceed the specified maximum storage temperature ( $T_{stg\ max}$ ). If the printed-circuit board has been pre-heated, forced cooling may be necessary immediately after soldering to keep the temperature within the permissible limit.

##### REPAIRING SOLDERED JOINTS

Apply a low voltage soldering iron (less than 24 V) to the lead(s) of the package, below the seating plane or not more than 2 mm above it. If the temperature of the soldering iron bit is less than 300 °C it may remain in contact for up to 10 seconds. If the bit temperature is between 300 and 400 °C, contact may be up to 5 seconds.

#### SO

##### REFLOW SOLDERING

Reflow soldering techniques are suitable for all SO packages.

Reflow soldering requires solder paste (a suspension of fine solder particles, flux and binding agent) to be applied to the printed-circuit board by screen printing, stencilling or pressure-syringe dispensing before package placement.

Several techniques exist for reflowing; for example, thermal conduction by heated belt. Dwell times vary between 50 and 300 seconds depending on heating method. Typical reflow temperatures range from 215 to 250 °C.

Preheating is necessary to dry the paste and evaporate the binding agent. Preheating duration: 45 minutes at 45 °C.

##### WAVE SOLDERING

Wave soldering techniques can be used for all SO packages if the following conditions are observed:

- A double-wave (a turbulent wave with high upward pressure followed by a smooth laminar wave) soldering technique should be used.
- The longitudinal axis of the package footprint must be parallel to the solder flow.
- The package footprint must incorporate solder thieves at the downstream end.

During placement and before soldering, the package must be fixed with a droplet of adhesive. The adhesive can be applied by screen printing, pin transfer or syringe dispensing. The package can be soldered after the adhesive is cured.

Maximum permissible solder temperature is 260 °C, and maximum duration of package immersion in solder is 10 seconds, if cooled to less than 150 °C within 6 seconds. Typical dwell time is 4 seconds at 250 °C.

A mildly-activated flux will eliminate the need for removal of corrosive residues in most applications.

##### REPAIRING SOLDERED JOINTS

Fix the component by first soldering two diagonally-opposite end leads. Use only a low voltage soldering iron (less than 24 V) applied to the flat part of the lead. Contact time must be limited to 10 seconds at up to 300 °C. When using a dedicated tool, all other leads can be soldered in one operation within 2 to 5 seconds between 270 and 320 °C.

## PLL stereo decoder

TEA5581  
TEA5581T**DEFINITIONS**

<b>Data sheet status</b>	
Objective specification	This data sheet contains target or goal specifications for product development.
Preliminary specification	This data sheet contains preliminary data; supplementary data may be published later.
Product specification	This data sheet contains final product specifications.
<b>Limiting values</b>	
Limiting values given are in accordance with the Absolute Maximum Rating System (IEC 134). Stress above one or more of the limiting values may cause permanent damage to the device. These are stress ratings only and operation of the device at these or at any other conditions above those given in the Characteristics sections of the specification is not implied. Exposure to limiting values for extended periods may affect device reliability.	
<b>Application information</b>	
Where application information is given, it is advisory and does not form part of the specification.	

**LIFE SUPPORT APPLICATIONS**

These products are not designed for use in life support appliances, devices, or systems where malfunction of these products can reasonably be expected to result in personal injury. Philips customers using or selling these products for use in such applications do so at their own risk and agree to fully indemnify Philips for any damages resulting from such improper use or sale.