

DATA SHEET

TEA0655

Dual Dolby B-type noise reduction
circuit for playback applications

Product specification
File under Integrated Circuits, IC01

September 1990

Dual Dolby B-type noise reduction circuit for playback applications

TEA0655

GENERAL DESCRIPTION

The TEA0655 is an integrated circuit that provides two Dolby* B-type noise reduction channels for playback applications in car radios. The TEA0655 includes head and equalization amplifiers with electronically switched time constants. The device will operate with power supplies in the range 9 to 15 volts, the output overload level increasing with an increase in supply voltage. Current drain varies with supply voltage and noise reduction ON/OFF, therefore it is advisable to use a regulated power supply or a supply with a long time constant.

FEATURES

- Dual noise reduction channels
- Head preamplifiers
- Equalization with electronically switched time constants
- Dolby reference level = 387.5 mV.

QUICK REFERENCE DATA

SYMBOL	PARAMETER	MIN.	TYP.	MAX.	UNIT
V_{CC}	supply voltage range	8	–	15	V
I_{CC}	supply current	–	20	25	mA
(S+N)/N	signal plus noise-to-noise ratio	78	84	–	dB

ORDERING AND PACKAGE INFORMATION

EXTENDED TYPE NUMBER	PACKAGE			
	PINS	PIN POSITION	MATERIAL	CODE
TEA0655	20	DIL	plastic	SOT146 **

* Available only to licensees of Dolby Laboratories Licensing Corporation, San Francisco, CA94111, USA, from whom licensing and application information must be obtained. Dolby is a registered trade-mark of Dolby Laboratories Licensing Corporation.

** SOT146-1, August 1996.

Dual Dolby B-type noise reduction circuit for playback applications

TEA0655

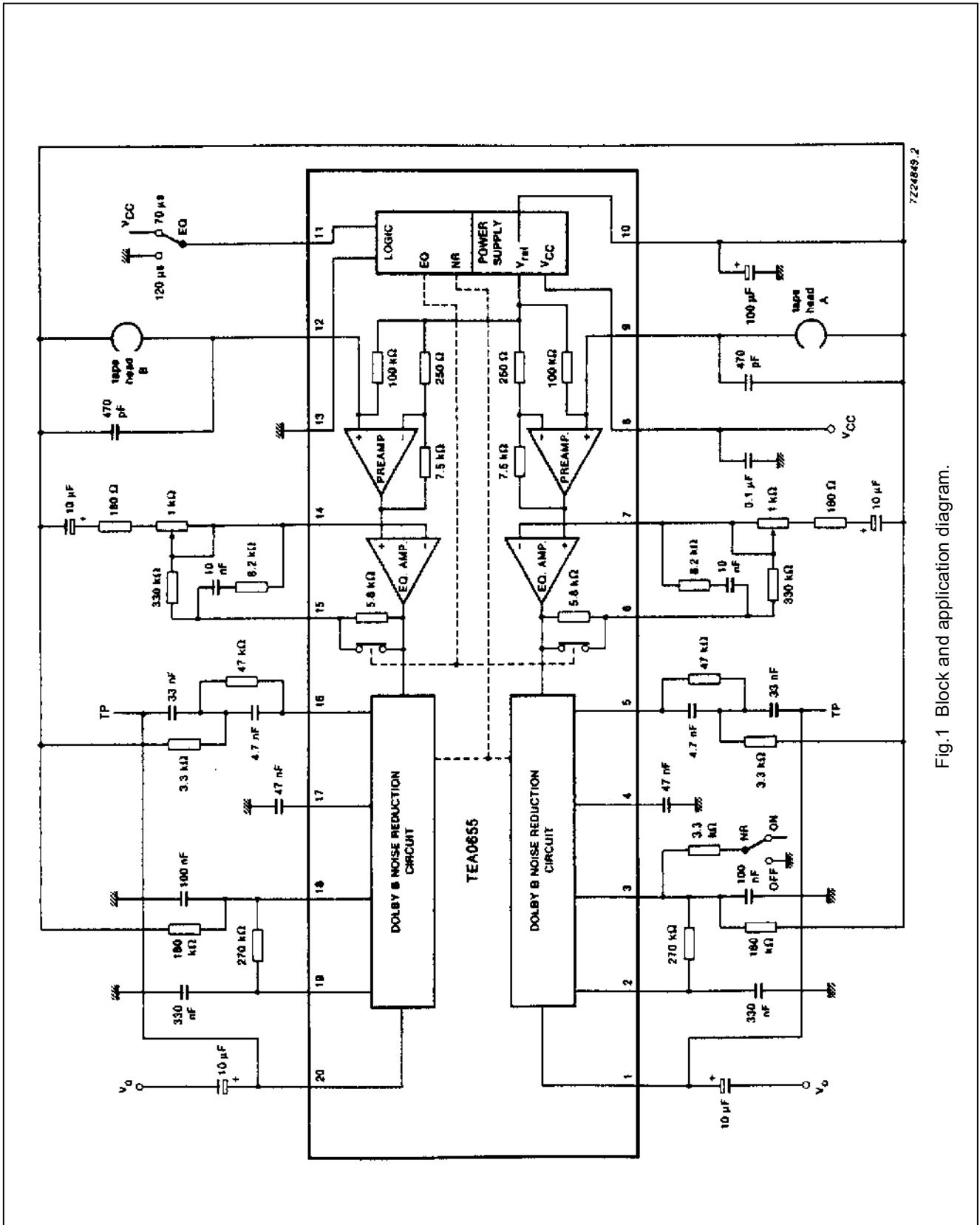

Fig.1 Block and application diagram.

Dual Dolby B-type noise reduction circuit for playback applications

TEA0655

FUNCTIONAL DESCRIPTION

Noise reduction is enabled when pin 3 is open-circuit and disabled when pin 3 is connected to GRD (pin 13) via a 3.3 k Ω resistor (see Fig.1).

Pin 3 performs the functions of a logic input for noise reduction switching for both channels. It also provides smoothing for the control signal in one channel. It is important that no voltage is applied to pin 3 when in the NR ON mode as this will cause irregular noise reduction characteristics in the selected channel. Time constant switching is achieved by applying a DC voltage to pin 11.

PINNING

SYMBOL	PIN	DESCRIPTION
OUTA	1	output channel A
INTA	2	integrating filter channel A
CONTRA	3	control voltage channel A
HPA	4	high-pass filter channel A
SCA	5	side chain channel A
EQA	6	equalizing output channel A
EQFA	7	equalizing input channel A
V _{CC}	8	voltage supply
INA	9	input channel A
V _{ref}	10	reference voltage
SWEQ	11	equalizing switch
INB	12	input channel B
GRD	13	ground
EQFB	14	equalizing input channel B
EQB	15	equalizing output channel B
SCB	16	side chain channel B
HPB	17	high-pass filter channel B
CONTRB	18	control voltage channel B
INTB	19	integrating filter channel B
OUTB	20	output channel B

LIMITING VALUES

Limiting values in accordance with the Absolute Maximum Rating System (IEC 134)

SYMBOL	PARAMETER	MIN.	MAX.	UNIT
V _{CC}	supply voltage	–	16	V
V _I	input voltage (pins 1 to 20)	–0.3	V _{CC}	V
T _{amb}	operating ambient temperature range	–40	+85	°C
T _{stg}	storage temperature range	–65	+150	°C
V _{es}	electrostatic handling *	–	–	–

* Classification A: human body model; C = 100 pF, R = 1.5 k Ω , V = \geq 2 kV; charge device model; C = 200 pF, R = 0 Ω , V \geq 500 V.

Dual Dolby B-type noise reduction circuit for playback applications

TEA0655

CHARACTERISTICS

$V_{CC} = 10\text{ V}$; $f = 20\text{ Hz}$ to 20 kHz ; $T_{amb} = +25\text{ °C}$; all levels referenced to 387.5 mV RMS (0 dB) at test point (TP) (pin 1 or 20); test circuit Fig.1; NR ON; EQ switch in the $70\text{ }\mu\text{s}$ position; unless otherwise specified.

SYMBOL	PARAMETER	CONDITIONS	MIN.	TYP.	MAX.	UNIT
V_{CC}	supply voltage		8	10	15	V
I_{CC}	supply current		–	20	25	mA
	channel matching	NR OFF	–0.5	–	+0.5	dB
THD	distortion 2nd and 3rd harmonic	$f = 1\text{ kHz}$; 0 dB	–	0.08	0.15	%
		$f = 10\text{ kHz}$; +10 dB	–	0.15	0.3	%
	signal handling	$V_{CC} = 8\text{ V}$; 1% distortion at 1 kHz	12	15	–	dB
(S+N)/N	signal-plus-noise to noise ratio (see Fig.2; decode mode)	internal gain 40 dB linear; CCIR/ARM weighted	78	84	–	dB
PSRR	power supply ripple rejection	$f = 1\text{ kHz}$; 250 mV; see Fig.3	52	57	–	dB
	frequency response measured in encode mode see Fig.2 referenced to test point	note 1				
		$f = 1\text{ kHz}$; 0 dB	–1.5	0	+1.5	dB
		$f = 1\text{ kHz}$; –25 dB	–17.8	–19.3	–20.8	dB
		$f = 0.2\text{ kHz}$; –25 dB	–22.9	–24.4	–25.9	dB
		$f = 5\text{ kHz}$; –25 dB	–18.1	–19.6	–21.1	dB
		$f = 10\text{ kHz}$; –35 dB	–24.4	–25.9	–27.4	dB
α_{CR}	channel separation	$f = 1\text{ kHz}$; see Fig.4	57	63	–	dB
R_{Lmin}	minimum load resistance on output (pins 1 and 20)	12 dB; 1 kHz; 1% THD	10	–	–	k Ω
G_V	voltage gain (pin 9 to 7 or pin 12 to 14)	1 kHz	29	30	31	dB
V_{off}	input offset voltage		–	2	–	mV
I_B	input bias current		–	0.1	0.4	μA
R_{EQ}	equalizing resistor		4.7	5.8	6.9	k Ω
R_I	input resistance pins 9 and 12		60	100	–	k Ω

Dual Dolby B-type noise reduction circuit for playback applications

TEA0655

SYMBOL	PARAMETER	CONDITIONS	MIN.	TYP.	MAX.	UNIT
A_V	open loop gain pins 12/15 and pins 9/6	10 kHz	80	86	–	dB
		400 kHz	104	110	–	dB
	DC output voltage pins 1 and 20	NR OFF with reference to $V_{CC}/2$	–	–	± 0.15	V
Z_O	output impedance		–	50	70	Ω
I_{OGRD}	DC output current capability	to ground	–	–	–2	mA
I_{OVCC}		to V_{CC}	–	–	300	μA
E_n	equivalent input noise voltage (RMS value)	NR OFF; unweighted; 20 Hz to 20 kHz; $R_S = 0 \Omega$	–	0.7	1.4	μV
Switching thresholds						
V_{OFF}	NR switch OFF (pin 3)		0	–	$0.2V_{CC}$	V
I_3	NR switch ON		–	open	–100	nA
	equalizing (EQ) switch (pin 11) at 70 μs		$0.5V_{CC}$	–	V_{CC}	V
	equalizing switch at 120 μs		0	–	$0.2V_{CC}$	V
I_{11}	input current		–	–	–1	μA

Note to the characteristics

1. Equals the corresponding decode mode cut with reference to test point level, see Fig.1.

Dual Dolby B-type noise reduction circuit for playback applications

TEA0655

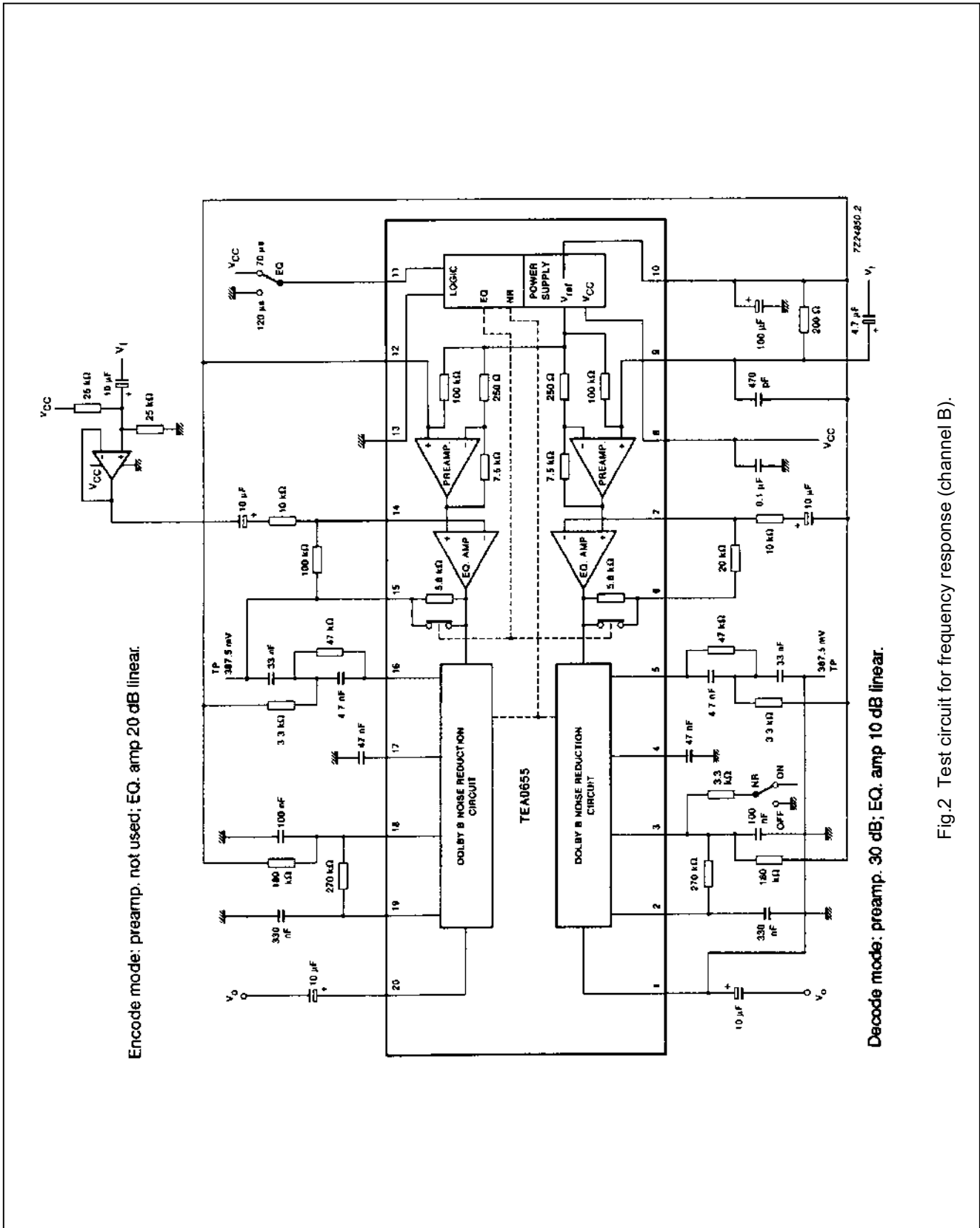

Encode mode: preamp. not used; EQ. amp 20 dB linear.

Decode mode: preamp. 30 dB; EQ. amp 10 dB linear.

Fig.2 Test circuit for frequency response (channel B).

Dual Dolby B-type noise reduction circuit for playback applications

TEA0655

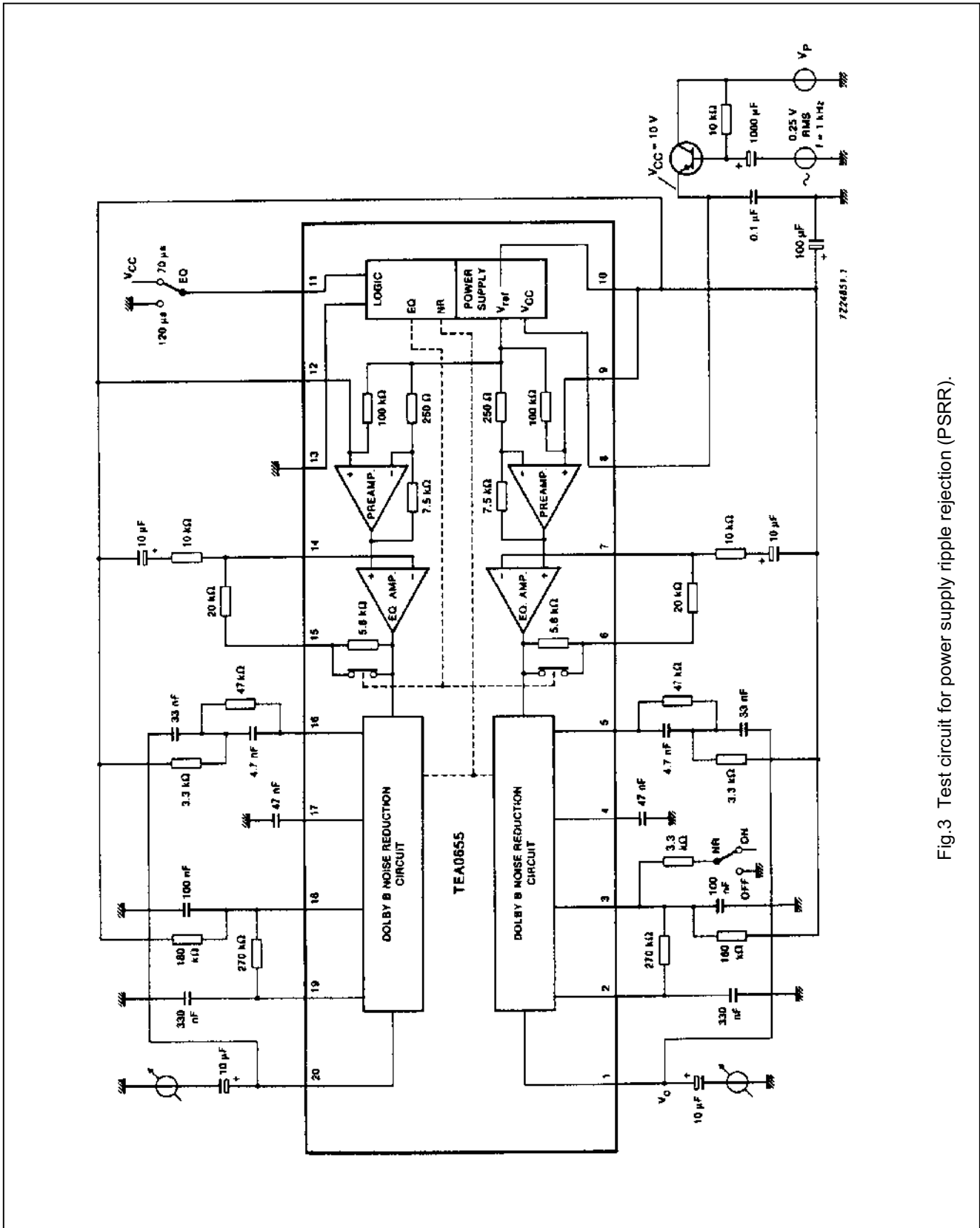

Fig.3 Test circuit for power supply ripple rejection (PSRR).

Dual Dolby B-type noise reduction circuit for playback applications

TEA0655

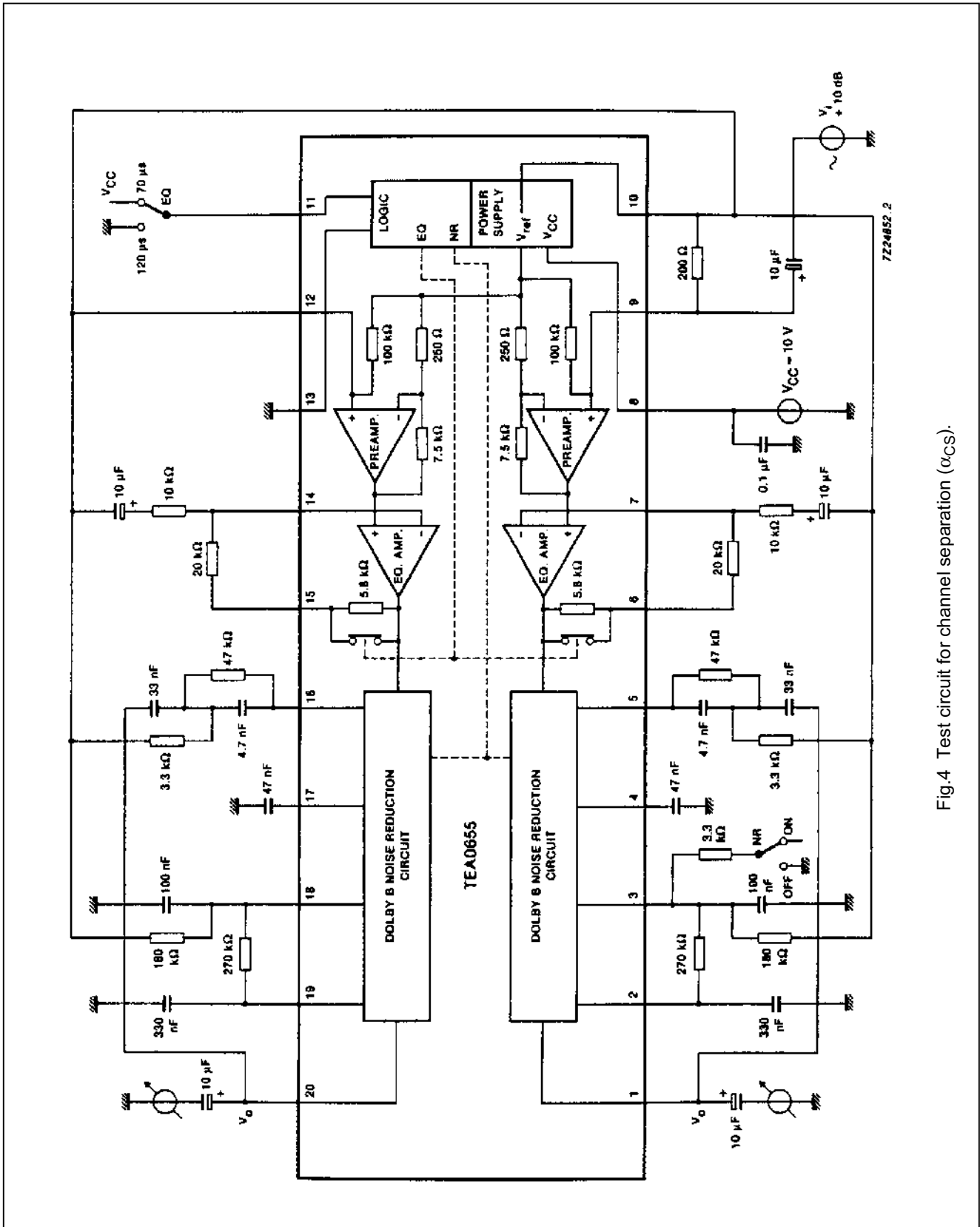

Fig.4 Test circuit for channel separation (α_{CS}).

Dual Dolby B-type noise reduction circuit for playback applications

TEA0655

PACKAGE OUTLINE

DIP20: plastic dual in-line package; 20 leads (300 mil)

SOT146-1

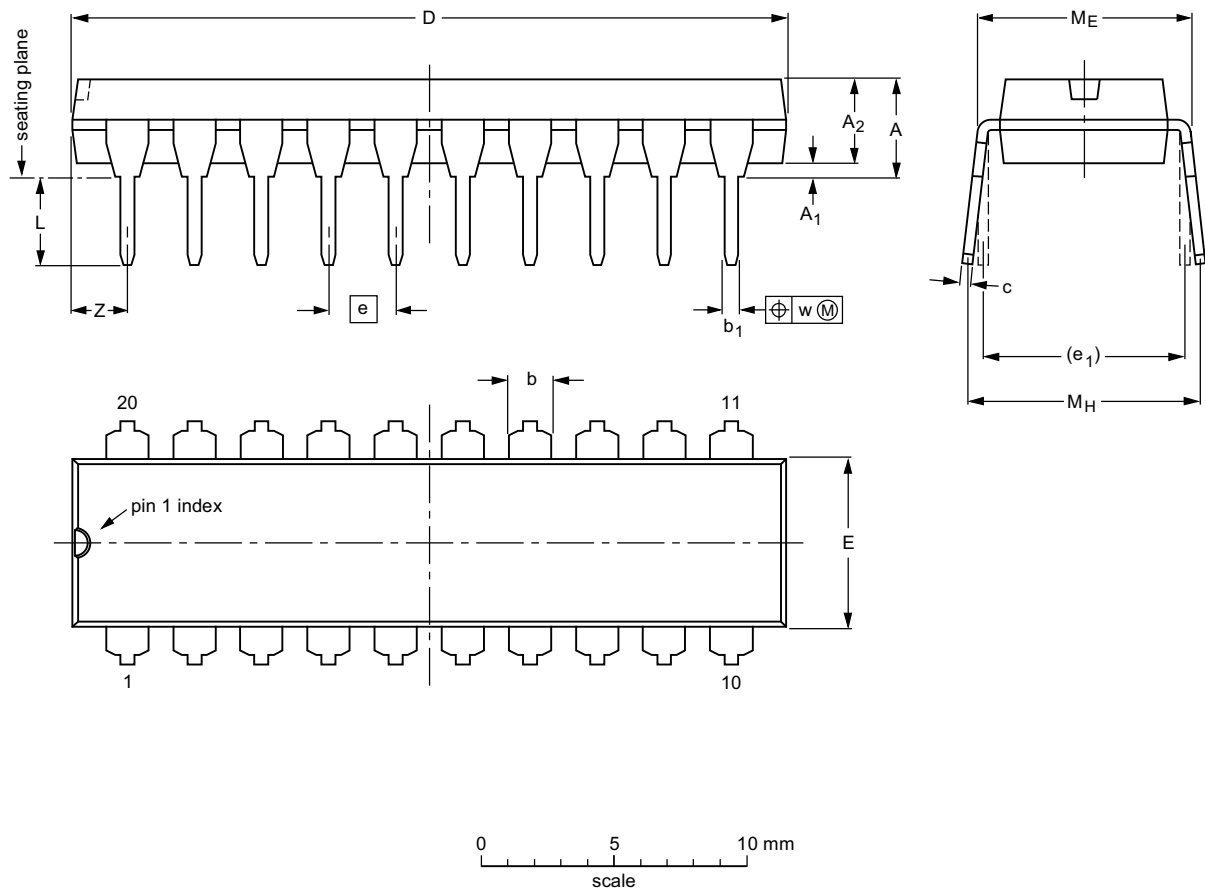

DIMENSIONS (inch dimensions are derived from the original mm dimensions)

UNIT	A max.	A ₁ min.	A ₂ max.	b	b ₁	c	D ⁽¹⁾	E ⁽¹⁾	e	e ₁	L	M _E	M _H	w	Z ⁽¹⁾ max.
mm	4.2	0.51	3.2	1.73 1.30	0.53 0.38	0.36 0.23	26.92 26.54	6.40 6.22	2.54	7.62	3.60 3.05	8.25 7.80	10.0 8.3	0.254	2.0
inches	0.17	0.020	0.13	0.068 0.051	0.021 0.015	0.014 0.009	1.060 1.045	0.25 0.24	0.10	0.30	0.14 0.12	0.32 0.31	0.39 0.33	0.01	0.078

Note

1. Plastic or metal protrusions of 0.25 mm maximum per side are not included.

OUTLINE VERSION	REFERENCES				EUROPEAN PROJECTION	ISSUE DATE
	IEC	JEDEC	EIAJ			
SOT146-1			SC603			92-11-17 95-05-24

Dual Dolby B-type noise reduction circuit for playback applications

TEA0655

SOLDERING

Introduction

There is no soldering method that is ideal for all IC packages. Wave soldering is often preferred when through-hole and surface mounted components are mixed on one printed-circuit board. However, wave soldering is not always suitable for surface mounted ICs, or for printed-circuits with high population densities. In these situations reflow soldering is often used.

This text gives a very brief insight to a complex technology. A more in-depth account of soldering ICs can be found in our "IC Package Databook" (order code 9398 652 90011).

Soldering by dipping or by wave

The maximum permissible temperature of the solder is 260 °C; solder at this temperature must not be in contact with the joint for more than 5 seconds. The total contact time of successive solder waves must not exceed 5 seconds.

The device may be mounted up to the seating plane, but the temperature of the plastic body must not exceed the specified maximum storage temperature ($T_{stg\ max}$). If the printed-circuit board has been pre-heated, forced cooling may be necessary immediately after soldering to keep the temperature within the permissible limit.

Repairing soldered joints

Apply a low voltage soldering iron (less than 24 V) to the lead(s) of the package, below the seating plane or not more than 2 mm above it. If the temperature of the soldering iron bit is less than 300 °C it may remain in contact for up to 10 seconds. If the bit temperature is between 300 and 400 °C, contact may be up to 5 seconds.

DEFINITIONS

Data sheet status	
Objective specification	This data sheet contains target or goal specifications for product development.
Preliminary specification	This data sheet contains preliminary data; supplementary data may be published later.
Product specification	This data sheet contains final product specifications.
Limiting values	
Limiting values given are in accordance with the Absolute Maximum Rating System (IEC 134). Stress above one or more of the limiting values may cause permanent damage to the device. These are stress ratings only and operation of the device at these or at any other conditions above those given in the Characteristics sections of the specification is not implied. Exposure to limiting values for extended periods may affect device reliability.	
Application information	
Where application information is given, it is advisory and does not form part of the specification.	

LIFE SUPPORT APPLICATIONS

These products are not designed for use in life support appliances, devices, or systems where malfunction of these products can reasonably be expected to result in personal injury. Philips customers using or selling these products for use in such applications do so at their own risk and agree to fully indemnify Philips for any damages resulting from such improper use or sale.