

DATA SHEET

TDA9817; TDA9818 Single/multistandard VIF/SIF-PLL and FM-PLL/AM demodulators

Preliminary specification
Supersedes data of 1997 May 12
File under Integrated Circuits, IC02

2001 Oct 19

Single/multistandard VIF/SIF-PLL and FM-PLL/AM demodulators

TDA9817; TDA9818

FEATURES

- 5 V supply voltage
- Applicable for Intermediate Frequencies (IFs) of 38.9, 45.75 and 58.75 MHz
- Gain controlled wide band Video IF (VIF) amplifier (AC-coupled)
- True synchronous demodulation with active carrier regeneration (very linear demodulation, good intermodulation figures, reduced harmonics and excellent pulse response)
- Robustness for over-modulation better than 105% due to gated phase detector at L/L accent standard and PLL-bandwidth control at negative modulated standards
- Voltage Controlled Oscillator (VCO) frequency switchable between L and L accent (alignment external) picture carrier frequency
- VIF Automatic Gain Control (AGC) detector for gain control, operating as peak sync detector for B/G, peak white detector for L; signal controlled reaction time for L
- Tuner AGC with adjustable TakeOver Point (TOP)
- Automatic Frequency Control (AFC) detector without extra reference circuit

- AC-coupled limiter amplifier for sound intercarrier signal
- Alignment-free FM Phase-Locked Loop (PLL) demodulator with high linearity
- Sound IF (SIF) input for single reference Quasi Split Sound (QSS) mode (PLL controlled); SIF AGC detector for gain controlled SIF amplifier; single reference QSS mixer able to operate in high performance single reference QSS mode and in intercarrier mode
- AM demodulator without extra reference circuit
- Stabilizer circuit for ripple rejection and to achieve constant output signals
- ElectroStatic Discharge (ESD) protection for all pins.

GENERAL DESCRIPTION

The TDA9817 is an integrated circuit for single standard vision IF signal processing and FM demodulation.

The TDA9818 is an integrated circuit for multistandard vision IF signal processing, sound AM and FM demodulation.

ORDERING INFORMATION

TYPE NUMBER	PACKAGE		
	NAME	DESCRIPTION	VERSION
TDA9817	SDIP24	plastic shrink dual in-line package; 24 leads (400 mil)	SOT234-1
TDA9817T	SO24	plastic small outline package; 24 leads; body width 7.5 mm	SOT137-1
TDA9817TS	SSOP24	plastic shrink small outline package; 24 leads; body width 5.3 mm	SOT340-1
TDA9818	SDIP24	plastic shrink dual in-line package; 24 leads (400 mil)	SOT234-1
TDA9818T	SO24	plastic small outline package; 24 leads; body width 7.5 mm	SOT137-1
TDA9818TS	SSOP24	plastic shrink small outline package; 24 leads; body width 5.3 mm	SOT340-1

Single/multistandard VIF/SIF-PLL and FM-PLL/AM demodulators

TDA9817; TDA9818

QUICK REFERENCE DATA

SYMBOL	PARAMETER	CONDITIONS	MIN.	TYP.	MAX.	UNIT
V_P	supply voltage		4.5	5	5.5	V
I_P	supply current		76	90	104	mA
$V_{i(VIF)(rms)}$	vision IF input signal voltage sensitivity (RMS value)	-1 dB video at output	-	60	100	μ V
$V_{o(CVBS)(p-p)}$	video output signal voltage (peak-to-peak value)		0.97	1.1	1.23	V
$B_{V(-3dB)}$	-3 dB video bandwidth on pin CVBS	B/G and L standard; $C_L < 50$ pF; $R_L > 1$ k Ω ; AC load	7	8	-	MHz
S/N_W	weighted signal-to-noise ratio for video		56	60	-	dB
$\alpha_{IM(1.1)}$	intermodulation attenuation at 'blue'	$f = 1.1$ MHz	58	64	-	dB
$\alpha_{IM(3.3)}$	intermodulation attenuation at 'blue'	$f = 3.3$ MHz	58	64	-	dB
$\alpha_{H(sup)}$	suppression of video signal harmonics		35	40	-	dB
$V_{i(SIF)(rms)}$	sound IF input signal voltage sensitivity (RMS value)	-3 dB at intercarrier output	-	50	100	μ V
$V_{o(FM)(rms)}$	audio output signal voltage for FM (RMS value)	B/G standard; 27 kHz, 54% modulation	0.4	0.5	0.6	V
		M/N standard; 25 kHz modulation	0.36	0.45	0.54	V
$V_{o(AM)(rms)}$	audio output signal voltage for AM (RMS value)	L standard; 54% modulation	0.4	0.5	0.6	V
THD _{audio}	total harmonic distortion audio signal	54% modulation				
	FM		-	0.2	0.5	%
	AM		-	0.5	1.0	%
$S/N_{W(audio)}$	weighted signal-to-noise ratio audio signal	54% modulation				
	FM		55	60	-	dB
	AM		47	53	-	dB

Single/multistandard VIF/SIF-PLL and FM-PLL/AM demodulators

TDA9817; TDA9818

BLOCK DIAGRAM

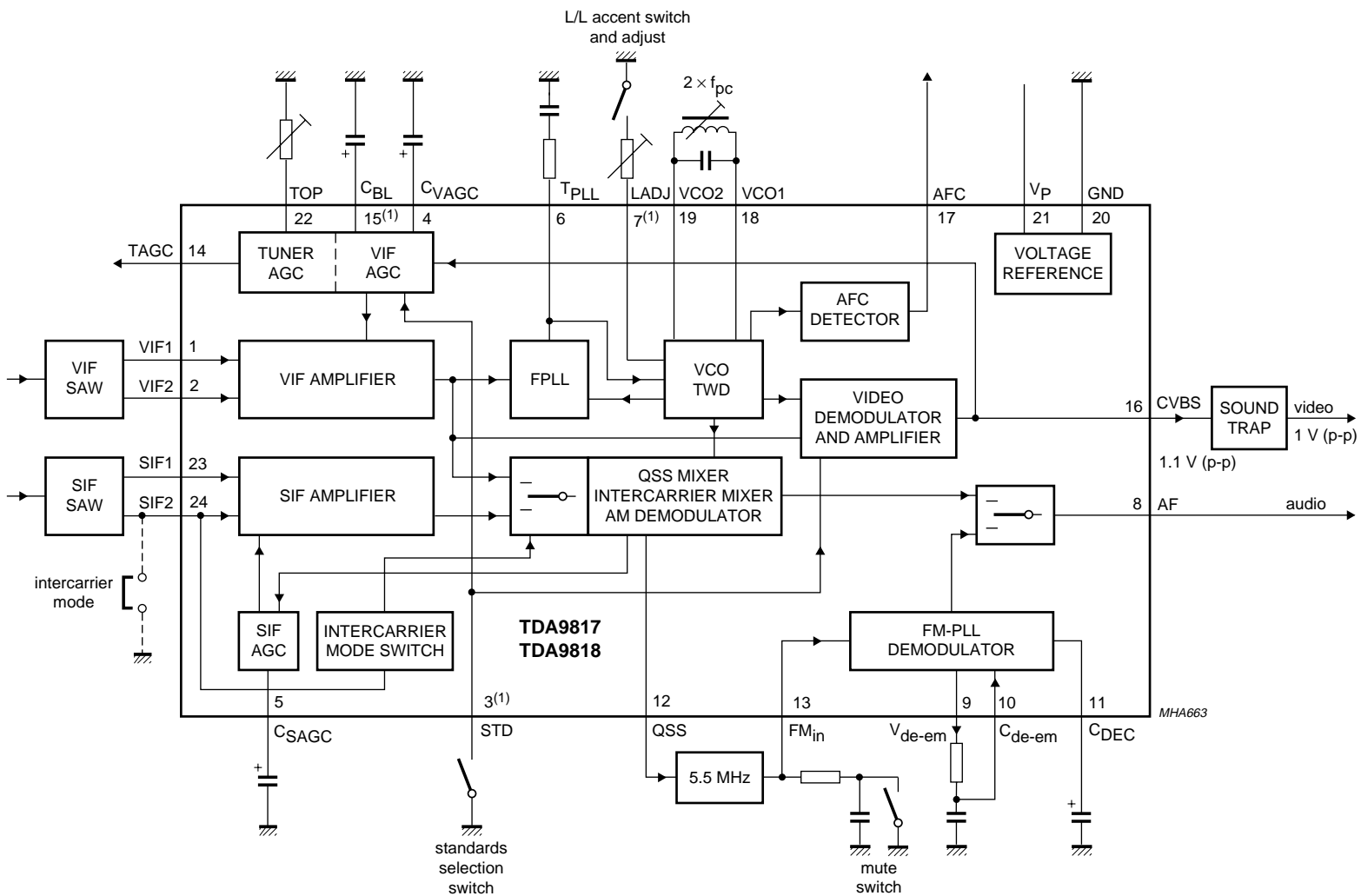

(1) Not connected for TDA9817, TDA9817T and TDA9817TS.

Fig.1 Block diagram.

Single/multistandard VIF/SIF-PLL and FM-PLL/AM demodulators

TDA9817; TDA9818

PINNING

SYMBOL	PIN	DESCRIPTION
VIF1	1	VIF differential input signal voltage 1
VIF2	2	VIF differential input signal voltage 2
STD	3	standards selection switch; note 1
C _{VAGC}	4	VIF AGC capacitor
C _{SAGC}	5	SIF AGC capacitor
T _{PLL}	6	PLL filter
LADJ	7	L/L accent switch and adjust; note 1
AF	8	audio output
V _{de-em}	9	de-emphasis output
C _{de-em}	10	de-emphasis input
C _{DEC}	11	decoupling capacitor
QSS	12	single reference QSS/intercarrier output voltage
FM _{in}	13	sound intercarrier input voltage
TAGC	14	tuner AGC output
C _{BL}	15	black level detector; note 1
CVBS	16	composite video output voltage
AFC	17	AFC output
VCO1	18	VCO1 resonance circuit
VCO2	19	VCO2 resonance circuit
GND	20	ground
V _P	21	supply voltage
TOP	22	tuner AGC takeover point adjust
SIF1	23	SIF differential input signal voltage 1
SIF2	24	SIF differential input signal voltage 2

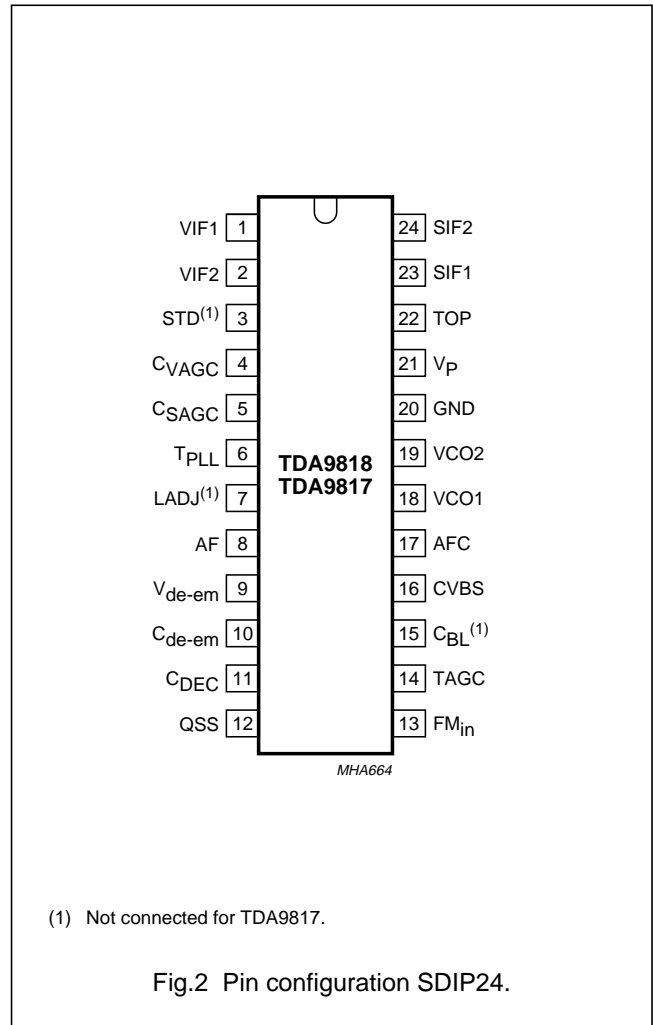

Fig.2 Pin configuration SDIP24.

Note

1. Not connected for TDA9817, TDA9817T and TDA9817TS.

Single/multistandard VIF/SIF-PLL and FM-PLL/AM demodulators

TDA9817; TDA9818

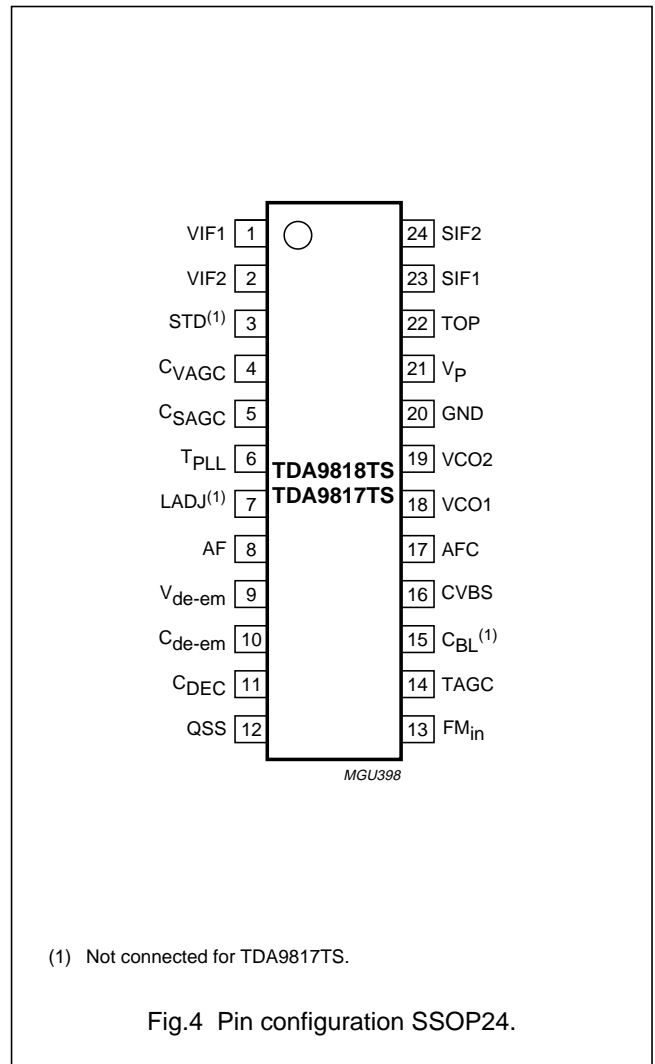
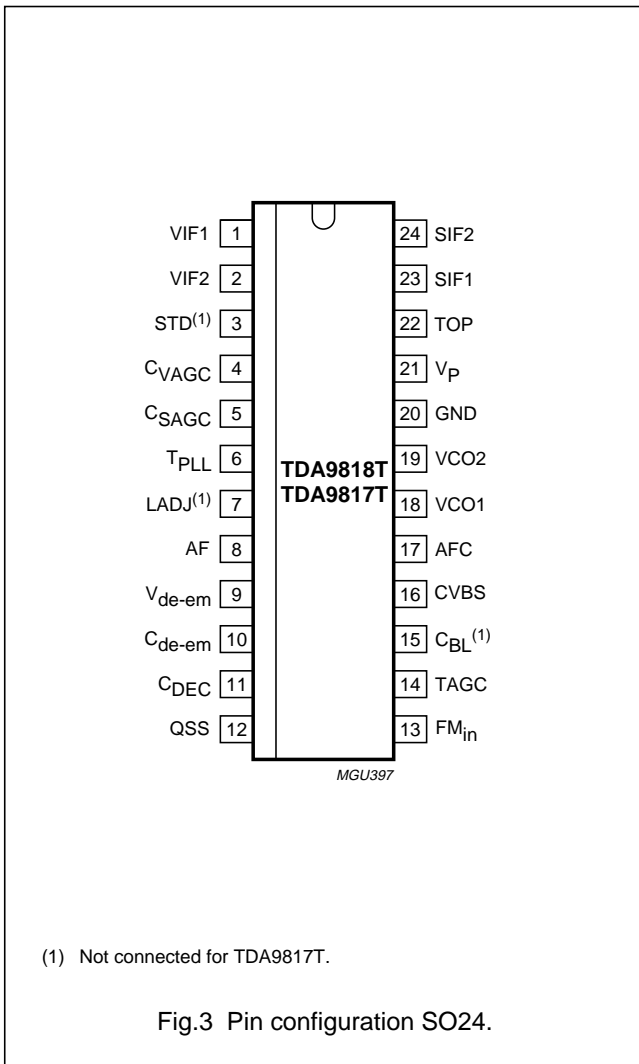

Single/multistandard VIF/SIF-PLL and FM-PLL/AM demodulators

TDA9817; TDA9818

FUNCTIONAL DESCRIPTION

The integrated circuit comprises the functional blocks as shown in Fig.1:

- Vision IF amplifier and VIF AGC detector
- Tuner AGC
- Frequency Phase Locked Loop detector (FPLL)
- VCO, Travelling Wave Divider (TWD) and AFC
- Video demodulator and amplifier
- Sound IF amplifier and SIF AGC
- Single reference QSS mixer
- AM demodulator
- FM-PLL demodulator
- Audio Frequency (AF) signal processing
- Internal voltage stabilizer.

Vision IF amplifier and VIF AGC detector

The vision IF amplifier consists of three AC-coupled differential amplifier stages. Each differential stage comprises a feedback network controlled by emitter degeneration.

The AGC detector generates the required VIF gain control voltage for constant video output by charging/discharging the AGC capacitor. Therefore for negative video modulation the sync level and for positive video modulation the peak white level of the video signal is detected. In order to reduce the reaction time for positive modulation, where a very large time constant is needed, an additional level detector increases the discharging current of the AGC capacitor (fast mode) in the event of a decreasing VIF amplitude step. The additional level information is given by the black-level detector voltage.

Tuner AGC

The AGC capacitor voltage is converted to an internal IF control signal, and is fed to the tuner AGC to generate the tuner AGC output current at pin TAGC (open-collector output). The tuner AGC takeover point can be adjusted at pin TADJ. This allows to match the tuner to the SAW filter in order to achieve the optimum IF input level.

Frequency Phase Locked Loop detector (FPLL)

The VIF-amplifier output signal is fed into a frequency detector and into a phase detector via a limiting amplifier. During acquisition the frequency detector produces a DC current proportional to the frequency difference between the input and the VCO signal. After frequency lock-in the phase detector produces a DC current

proportional to the phase difference between the VCO and the input signal. The DC current of either frequency detector or phase detector is converted into a DC voltage via the loop filter, which controls the VCO frequency. In the event of positive modulated signals the phase detector is gated by composite sync in order to avoid signal distortion for overmodulated VIF signals.

VCO, Travelling Wave Divider (TWD) and AFC

The VCO operates with a resonance circuit (with L and C in parallel) at double the picture carrier frequency. The VCO is controlled by two integrated variable capacitors. The control voltage required to tune the VCO from its free-running frequency to actually double the picture carrier frequency is generated by the frequency-phase detector (FPLL) and fed via the loop filter to the first variable capacitor. This control voltage is amplified and additionally converted into a current which represents the AFC output signal. At centre frequency the AFC output current is equal to zero.

For TDA9818: the VCO centre frequency can be decreased (required for L accent standard) by activating an additional internal capacitor. This is achieved by using the L accent switch. In this event the second variable capacitor can be controlled by a variable resistor at the L accent switch for setting the VCO centre frequency to the required L accent value.

The oscillator signal is divided by 2 with a TWD which generates two differential output signals with a 90 degree phase difference independent of the frequency.

Video demodulator and amplifier

The video demodulator is realized by a multiplier which is designed for low distortion and large bandwidth. The vision IF input signal is multiplied with the 'in phase' signal of the travelling wave divider output. In the demodulator stage the video signal polarity can be switched in accordance with the TV standard.

The demodulator output signal is fed via an integrated low-pass filter for attenuation of the carrier harmonics to the video amplifier. The video amplifier is realized by an operational amplifier with internal feedback and high bandwidth. A low-pass filter is integrated to achieve an attenuation of the carrier harmonics for B/G and L standard. The standard dependent level shift in this stage delivers the same sync level for positive and negative modulation. The video output signal at pin CVBS is 1.1 V (p-p) for nominal vision IF modulation, in order to achieve 1 V (p-p) at sound trap output.

Single/multistandard VIF/SIF-PLL and FM-PLL/AM demodulators

TDA9817; TDA9818

Sound IF amplifier and SIF AGC

The sound IF amplifier consists of two AC-coupled differential amplifier stages. Each differential stage comprises a controlled feedback network provided by emitter degeneration.

The SIF AGC detector is related to the SIF input signal (average level of AM or FM carrier) and controls the SIF amplifier to provide a constant SIF signal to the AM demodulator and single reference QSS mixer. At L standard (AM sound) the SIF AGC reaction time is set to 'slow' for nominal video conditions. But with a decreasing VIF amplitude step the SIF AGC is set to 'fast' mode controlled by the VIF AGC detector. In FM mode this reaction time is always 'fast'.

Single reference QSS mixer

The single reference QSS mixer is realized by a multiplier. The SIF amplifier output signal is fed to the single reference QSS mixer and converted to intercarrier frequency by the regenerated picture carrier (VCO). The mixer output signal is fed via a high-pass for attenuation of the video signal components to the output pin QSS. With this system a high performance hi-fi stereo sound processing can be achieved.

For a simplified application without a sound IF SAW filter the single reference QSS mixer can be switched to the intercarrier mode by connecting pin SIF2 to ground. In this mode the sound IF passes the vision IF SAW filter and the composite IF signal is fed to the single reference QSS mixer. This IF signal is multiplied with the 90 degree TWD output signal for converting the sound IF to intercarrier frequency. This composite intercarrier signal is fed to the output pin QSS, too. By using this quadrature detection, the low frequency video signals are removed.

AM demodulator

The AM demodulator is realized by a multiplier. The modulated SIF amplifier output signal is multiplied in phase with the limited (AM is removed) SIF amplifier output signal. The demodulator output signal is fed via an integrated low-pass filter for attenuation of the carrier harmonics to the AF amplifier.

FM-PLL demodulator

The FM-PLL demodulator consists of a limiter and an FM-PLL. The limiter provides the amplification and limitation of the FM sound intercarrier signal. The result is high sensitivity and AM suppression. The amplifier consists of 7 stages which are internally AC-coupled in order to minimize the DC offset.

Furthermore the AF output signal can be muted by connecting a resistor between the limiter input pin FM_{in} and ground.

The FM-PLL consists of an integrated relaxation oscillator, an integrated loop filter and a phase detector. The oscillator is locked to the FM intercarrier signal, output from the limiter. As a result of locking, the oscillator frequency tracks with the modulation of the input signal and the oscillator control voltage is superimposed by the AF voltage. The FM-PLL operates as an FM demodulator.

Audio Frequency signal processing

The AF amplifier consists of two parts:

1. The AF pre-amplifier for FM sound is an operational amplifier with internal feedback, high gain and high common mode rejection. The AF voltage from the PLL demodulator, by principle a small output signal, is amplified by approximately 33 dB. The low-pass characteristic of the amplifier reduces the harmonics of the intercarrier signal at the sound output terminal pin V_{de-em} at which the de-emphasis network for FM sound is applied. An additional DC control circuit is implemented to keep the DC level constant, independent of process spread.
2. The AF output amplifier (10 dB) provides the required output level by a rail-to-rail output stage. This amplifier makes use of an input selector for switching to AM, FM de-emphasis or mute state, controlled by the standard switching voltage and the mute switching voltage.

Internal voltage stabilizer

The bandgap circuit internally generates a voltage of approximately 1.25 V, independent of supply voltage and temperature. A voltage regulator circuit, connected to this voltage, produces a constant voltage of 3.6 V which is used as an internal reference voltage.

Single/multistandard VIF/SIF-PLL and FM-PLL/AM demodulators

TDA9817; TDA9818

LIMITING VALUES

In accordance with the Absolute Maximum Rating System (IEC 60134).

SYMBOL	PARAMETER	CONDITIONS	MIN.	MAX.	UNIT
V _P	supply voltage	TDA9817, TDA9817T, TDA9818 and TDA9818T: maximum chip temperature of 120 °C; note 1	–	5.5	V
		TDA9817TS and TDA9818TS: maximum chip temperature of 130 °C; note 1	–	5.5	V
V _n	voltage at pins VIF1, VIF2, STD, C _{VAGC} , C _{SAGC} , T _{PLL} , V _{de-em} , C _{de-em} , C _{DEC} , FM _{in} , TAGC, C _{BL} , AFC, V _P , TOP, SIF1 and SIF2		0	V _P	V
t _{sc(max)}	maximum short-circuit time to ground or V _P		–	10	s
V _{TAGC}	tuner automatic gain control output voltage		0	13.2	V
T _{stg}	storage temperature		–25	+150	°C
T _{amb}	ambient temperature		–20	+70	°C
V _{esd}	electrostatic handling voltage	note 2	–300	+300	V

Notes

- I_P = 104 mA; T_{amb} = 70 °C; R_{th(j-a)} = 65 K/W for TDA9817 and TDA9818, R_{th(j-a)} = 85 K/W for TDA9817T and TDA9818T, R_{th(j-a)} = 110 K/W for TDA9817TS and TDA9818TS.
- Machine model class B (L = 2.5 μH).

THERMAL CHARACTERISTICS

SYMBOL	PARAMETER	CONDITIONS	VALUE	UNIT
R _{th(j-a)}	thermal resistance from junction to ambient	in free air		
	TDA9817; TDA9818		65	K/W
	TDA9817T; TDA9818T		85	K/W
	TDA9817TS; TDA9818TS		110	K/W

Single/multistandard VIF/SIF-PLL and FM-PLL/AM demodulators

TDA9817; TDA9818

CHARACTERISTICS

$V_P = 5\text{ V}$; $T_{\text{amb}} = 25\text{ }^\circ\text{C}$; see Table 1 for input frequencies and levels; input level $V_{i(\text{VIF})(\text{rms})} = 10\text{ mV}$ (sync level for B/G, peak white level for L); IF input from $50\text{ }\Omega$ via broadband transformer 1 : 1; video modulation DSB; residual carrier B/G: 10%; L = 3%; video signal in accordance with "CCIR, line 17" or "NTC-7 Composite"; measurements taken in Fig.15; unless otherwise specified.

SYMBOL	PARAMETER	CONDITIONS	MIN.	TYP.	MAX.	UNIT
Supply (pin V_P)						
V_P	supply voltage	note 1	4.5	5	5.5	V
I_P	supply current		76	90	104	mA
Vision IF amplifier (pins VIF1 and VIF2)						
$V_{i(\text{VIF})(\text{rms})}$	input signal voltage sensitivity (RMS value)	B/G standard; -1 dB video at output	-	60	100	μV
$V_{i(\text{VIF})(\text{max})(\text{rms})}$	maximum input signal voltage (RMS value)	B/G standard; 1 dB video at output	120	200	-	mV
$\Delta V_{(\text{IF})(\text{int})}$	internal IF amplitude difference between picture and sound carrier	within AGC range; B/G standard; $\Delta f = 5.5\text{ MHz}$	-	0.7	1	dB
$G_{\text{IF}(\text{ctrl})}$	IF gain control range	see Fig.5	65	70	-	dB
$R_{i(\text{dif})}$	differential input resistance	note 2	1.7	2.2	2.7	$\text{k}\Omega$
$C_{i(\text{dif})}$	differential input capacitance	note 2	1.2	1.7	2.5	pF
$V_{I(\text{VIF})}$	DC input voltage	note 2	-	3.4	-	V
True synchronous video demodulator; note 3						
$f_{\text{VCO}(\text{max})}$	maximum oscillator frequency for carrier regeneration	$f = 2f_{\text{pc}}$	125	130	-	MHz
$\Delta f_{\text{osc}}/\Delta T$	oscillator drift as a function of temperature	oscillator is free-running; $I_{\text{AFC}} = 0$; note 4	-	-	$\pm 20 \times 10^{-6}$	K^{-1}
$\Delta f_{\text{osc}}/\Delta V_P$	oscillator shift as a function of supply voltage	oscillator is free-running; note 4	-	-	$\pm 1.5 \times 10^{-3}$	V^{-1}
$V_{\text{VCO}(\text{rms})}$	oscillator voltage swing at pins VCO1 and VCO2 (RMS value)		50	80	110	mV
$f_{\text{cr}(\text{pc})}$	picture carrier capture range	B/G, M/N and L standard	± 1.4	± 1.8	-	MHz
		L accent standard; $f_{\text{pc}} = 33.9\text{ MHz}$; $R_{\text{LADJ}} = 5.6\text{ k}\Omega$	± 0.9	± 1.2	-	MHz
$\Delta f_{\text{pc}(\text{fr})}$	picture carrier frequency (free-running) accuracy	L accent standard; $f_{\text{pc}} = 33.9\text{ MHz}$; $R_{\text{LADJ}} = 5.6\text{ k}\Omega$	-	± 200	± 400	kHz
$f_{\text{align}(\text{Laccent})}$	L accent alignment frequency range	L accent standard; $I_{\text{AFC}} = 0$	± 400	± 600	-	kHz
t_{acq}	acquisition time	BL = 70 kHz; note 5	-	-	30	ms

Single/multistandard VIF/SIF-PLL and
FM-PLL/AM demodulators

TDA9817; TDA9818

SYMBOL	PARAMETER	CONDITIONS	MIN.	TYP.	MAX.	UNIT
$V_{i(VIF)(sens)(rms)}$	VIF input signal voltage sensitivity for PLL to be locked (RMS value); pins VIF1 and VIF2	maximum IF gain; note 6	–	30	70	μV
Composite video amplifier (pin CVBS); sound carrier off						
$V_{o(CVBS)(p-p)}$	output signal voltage (peak-to-peak value)	see Fig.10	0.97	1.1	1.23	V
V/S	ratio between video (black-to-white) and sync level		1.9	2.33	3.0	
$\Delta V_{o(CVBS)}$	output signal voltage difference	difference between B/G and L standard	–	–	± 12	%
V_{sync}	sync voltage level	B/G and L standard	1.4	1.5	1.6	V
$V_{clip(u)}$	upper video clipping voltage level		$V_P - 1.1$	$V_P - 1$	–	V
$V_{clip(l)}$	lower video clipping voltage level		–	0.7	0.9	V
R_o	output resistance	note 2	–	–	10	Ω
$I_{bias(int)}$	internal DC bias current for emitter-follower		2.2	3.0	–	mA
$I_{o(sink)(max)}$	maximum AC and DC output sink current		1.6	–	–	mA
$I_{o(source)(max)}$	maximum AC and DC output source current		2.9	–	–	mA
$\Delta V_{o(CVBS)(B/G)}$	deviation of CVBS output signal voltage at B/G standard	50 dB gain control	–	–	0.5	dB
		30 dB gain control	–	–	0.1	dB
$\Delta V_{o(BL)(B/G)}$	black level tilt in B/G standard	gain variation; note 7	–	–	1	%
$\Delta V_{o(BL)(L)}$	vertical black level tilt for worst case in L standard	vision carrier modulated by test line (VITS) only; gain variation; note 7	–	–	1.9	%
G_{dif}	differential gain	"CCIR, line 330"	–	2	5	%
ϕ_{dif}	differential phase	"CCIR, line 330"	–	1	2	deg
$B_{v(-1dB)}$	–1 dB video bandwidth	B/G and L standard; $C_L < 50 \text{ pF}$; $R_L > 1 \text{ k}\Omega$; AC load	5	6	–	MHz
$B_{v(-3dB)}$	–3 dB video bandwidth	B/G and L standard; $C_L < 50 \text{ pF}$; $R_L > 1 \text{ k}\Omega$; AC load	7	8	–	MHz
S/N_W	weighted signal-to-noise ratio	see Fig.7; note 8	56	60	–	dB
S/N	unweighted signal-to-noise ratio	see Fig.7; note 8	49	53	–	dB

Single/multistandard VIF/SIF-PLL and
FM-PLL/AM demodulators

TDA9817; TDA9818

SYMBOL	PARAMETER	CONDITIONS	MIN.	TYP.	MAX.	UNIT
$\alpha_{IM(1.1)}$	intermodulation attenuation at 'blue'	f = 1.1 MHz; see Fig.8; note 9	58	64	–	dB
	intermodulation attenuation at 'yellow'	f = 1.1 MHz; see Fig.8; note 9	60	66	–	dB
$\alpha_{IM(3.3)}$	intermodulation attenuation at 'blue'	f = 3.3 MHz; see Fig.8; note 9	58	64	–	dB
	intermodulation attenuation at 'yellow'	f = 3.3 MHz; see Fig.8; note 9	59	65	–	dB
$\Delta f_{unwanted(p-p)}$	robustness for unwanted frequency deviation of picture carrier (peak-to-peak value)	L standard; residual carrier: 3%; serration pulses: 50%; note 2	–	–	12	kHz
$\Delta\phi$	robustness for modulator imbalance	L standard; residual carrier: 0%; serration pulses: 50%; note 2	–	–	3	%
$\alpha_{vc(rms)}$	residual vision carrier (RMS value)	fundamental wave and harmonics; B/G and L standard	–	2	5	mV
$\alpha_{H(sup)}$	suppression of video signal harmonics	note 10a	35	40	–	dB
$\alpha_{H(spur)}$	spurious elements	note 10b	40	–	–	dB
PSRR	power supply ripple rejection at pin CVBS	video signal; grey level; see Fig.13				
		B/G standard	30	35	–	dB
		L standard	26	30	–	dB
VIF AGC detector (pins C_{VAGC} and C_{BL})						
I_{ch}	charging current	B/G and L standard; note 7	0.75	1	1.25	mA
	additional charging current	L standard in event of missing VITS pulses and no white video content	1.9	2.5	3.1	μ A
I_{dch}	discharging current	B/G standard	15	20	25	μ A
		normal mode L	225	300	375	nA
		fast mode L	30	40	50	μ A
$t_{resp(inc)}$	AGC response to an increasing VIF step	B/G and L standard; note 11	–	0.05	0.1	ms/dB
$t_{resp(dec)}$	AGC response to a decreasing VIF step	B/G standard	–	2.2	3.5	ms/dB
		fast mode L	–	1.1	1.8	ms/dB
		normal mode L; note 11	–	150	240	ms/dB
ΔIF	VIF amplitude step for activating fast AGC mode	L standard	–2	–6	–10	dB
$V_{th(CBL)}$	threshold voltage level additional charging current	see Fig.10				
		L standard	1.95	2.0	2.05	V
		L standard; fast mode L	1.6	1.66	1.72	V

Single/multistandard VIF/SIF-PLL and
FM-PLL/AM demodulators

TDA9817; TDA9818

SYMBOL	PARAMETER	CONDITIONS	MIN.	TYP.	MAX.	UNIT
Tuner AGC (pin TAGC)						
$V_{i(rms)}$	IF input signal voltage for minimum starting point of tuner takeover (RMS value)	input at pins VIF1 and VIF2; $R_{TOP} = 22 \text{ k}\Omega$; $I_{TAGC} = 0.4 \text{ mA}$	–	2	5	mV
	IF input signal voltage for maximum starting point of tuner takeover (RMS value)	input at pins VIF1 and VIF2; $R_{TOP} = 0 \Omega$; $I_{TAGC} = 0.4 \text{ mA}$	50	100	–	mV
$V_{o(TAGC)}$	permissible output voltage	from external source; note 2	–	–	13.2	V
$V_{sat(TAGC)}$	saturation voltage	$I_{TAGC} = 1.5 \text{ mA}$	–	–	0.2	V
$\Delta V_{TOP(TAGC)}/\Delta T$	variation of takeover point by temperature	$I_{TAGC} = 0.4 \text{ mA}$	–	0.03	0.07	dB/K
$I_{TAGC(sink)}$	sink current	see Fig.5	–	–	5	μA
		no tuner gain reduction; $V_{TAGC} = 13.2 \text{ V}$ maximum tuner gain reduction	1.5	2	2.6	mA
ΔG_{IF}	IF slip by automatic gain control	tuner gain current from 20% to 80%	–	6	8	dB
AFC circuit (pin AFC); see Fig.9; note 12						
CR_{stps}	control steepness $\Delta I_{AFC}/\Delta f$	note 13				
		33.9 MHz	0.5	0.75	1.0	$\mu\text{A}/\text{kHz}$
		38.9 MHz	0.5	0.75	1.0	$\mu\text{A}/\text{kHz}$
		45.75 MHz	0.45	0.65	0.85	$\mu\text{A}/\text{kHz}$
$\Delta f_{IF}/\Delta T$	frequency variation by temperature	B/G and L standard; $I_{AFC} = 0$; note 4	–	–	$\pm 20 \times 10^{-6}$	K^{-1}
		L accent standard; $I_{AFC} = 0$; note 4	–	–	$\pm 60 \times 10^{-6}$	K^{-1}
$V_{o(AFC)}$	output voltage	upper limit	$V_P - 0.6$	$V_P - 0.3$	–	V
		lower limit	–	0.3	0.6	V
$I_{o(source)(AFC)}$	output source current		150	200	250	μA
$I_{o(sink)(AFC)}$	output sink current		150	200	250	μA
$\Delta I_{AFC(p-p)}$	residual video modulation current (peak-to-peak value)	B/G and L standard	–	20	30	μA

Single/multistandard VIF/SIF-PLL and
FM-PLL/AM demodulators

TDA9817; TDA9818

SYMBOL	PARAMETER	CONDITIONS	MIN.	TYP.	MAX.	UNIT
Sound IF amplifier (pins SIF1 and SIF2)						
$V_{i(SIF)(rms)}$	input signal voltage sensitivity (RMS value)	FM mode; -3 dB at intercarrier output pin QSS	-	50	100	μ V
		AM mode; -3 dB at AF output pin AF	-	50	100	μ V
$V_{i(max)(rms)}$	maximum input signal voltage (RMS value)	FM mode; 1 dB at intercarrier output pin QSS	65	100	-	mV
		AM mode; 1 dB at AF output pin AF	65	100	-	mV
$G_{SIF(ctrl)}$	SIF gain control range	FM and AM mode; see Fig.6	60	66	-	dB
$R_{i(dif)}$	differential input resistance	note 2	1.7	2.2	2.7	k Ω
$C_{i(dif)}$	differential input capacitance	note 2	1.2	1.7	2.5	pF
$V_{I(SIF)}$	DC input voltage		-	3.4	-	V
$\alpha_{SIF,VIF}$	crosstalk attenuation between SIF and VIF inputs	between pins VIF1 and VIF2, and pins SIF1 and SIF2; note 14	50	-	-	dB
SIF AGC detector (pin C_{SAGC})						
$I_{ch(CSAGC)}$	charging current	FM mode	8	12	16	μ A
		AM mode	0.8	1.2	1.6	μ A
$I_{dch(CSAGC)}$	discharging current	FM mode	8	12	16	μ A
		normal mode AM	1	1.4	1.8	μ A
		fast mode AM	60	85	110	μ A
Single reference QSS intercarrier mixer (B/G standard; pin QSS)						
$V_{o(rms)}$	IF intercarrier output level (RMS value)	QSS mode; sound carrier 1; sound carrier 2 off	100	140	180	mV
		L standard; without modulation	100	140	180	mV
		intercarrier mode; sound carrier 1; sound carrier 2 off	-	note 15	-	mV
$V_{o(peak)}$	IF intercarrier output level (peak value)	QSS mode	141	198	225	mV
		L standard; 80% AM modulation	255	356	458	mV
$B_{s(-3dB)}$	-3 dB intercarrier bandwidth	upper limit	7.5	9	-	MHz
$\alpha_{sc(rms)}$	residual sound carrier (RMS value)	QSS mode; fundamental wave and harmonics	-	2	5	mV
		intercarrier mode; fundamental wave and harmonics	-	2	5	mV

Single/multistandard VIF/SIF-PLL and
FM-PLL/AM demodulators

TDA9817; TDA9818

SYMBOL	PARAMETER	CONDITIONS	MIN.	TYP.	MAX.	UNIT
$\alpha_{vc(rms)}$	residual vision carrier (RMS value)	QSS mode; fundamental wave and harmonics	–	2	5	mV
		intercarrier mode; fundamental wave and harmonics	–	5	20	mV
$\alpha_{H(sup)}$	suppression of video signal harmonics	intercarrier mode; $f_{video} \leq 5$ MHz	39	–	–	dB
$R_{o(QSS)}$	output resistance	note 2	–	–	25	Ω
$V_{O(QSS)}$	DC output voltage		–	2.0	–	V
$I_{int(QSS)}$	DC internal bias current for emitter follower		1.9	2.5	–	mA
$I_{sink(max)(QSS)}$	maximum AC and DC output sink current		1.4	1.9	–	mA
$I_{source(max)(QSS)}$	maximum AC and DC output source current		3.0	3.5	–	mA
Limiting amplifier (pin FM_{in}); note 16						
$V_{i(FMin)(rms)}$	input signal voltage for lock-in (RMS value)		–	–	100	μ V
$V_{i(FMin)(rms)}$	input signal voltage (RMS value)	$\left(\frac{S+N}{N}\right)$ weighted = 40 dB	–	250	400	μ V
	allowed input signal voltage (RMS value)		200	–	–	mV
α_{AM}	AM suppression	50 μ s de-emphasis; AM: $f = 1$ kHz; $m = 0.3$ refer to 27 kHz (54% FM deviation)	46	50	–	dB
$R_{i(FMin)}$	input resistance	note 2	480	600	720	Ω
$V_{I(FMin)}$	DC input voltage		–	2.8	–	V
FM-PLL demodulator						
f_{cr}	catching range of PLL	upper limit	7.0	–	–	MHz
		lower limit	–	–	4.0	MHz
f_{hr}	holding range of PLL	upper limit	9.0	–	–	MHz
		lower limit	–	–	3.5	MHz
t_{acq}	acquisition time		–	–	4	μ s

Single/multistandard VIF/SIF-PLL and
FM-PLL/AM demodulators

TDA9817; TDA9818

SYMBOL	PARAMETER	CONDITIONS	MIN.	TYP.	MAX.	UNIT
FM operation (B/G standard; pin AF); notes 16 and 16a						
$V_{o(AF)(rms)}$	AF output signal voltage (RMS value)	27 kHz (54% FM deviation); see Fig.15; note 17 $R_x = 470 \Omega$	200	250	300	mV
		$R_x = 0 \Omega$	400	500	600	mV
		25 kHz (50% FM deviation); $R_x = 0 \Omega$; see Fig.15; note 17	360	450	540	mV
$V_{o(AF)(clip)}$	AF output clipping signal voltage level	THD < 1.5%	1.0	–	1.2	V
Δf_{AF}	frequency deviation	THD < 1.5%; note 17	–	–	± 53	kHz
$\Delta V_o/\Delta T$	temperature drift of AF output signal voltage		–	3×10^{-3}	7×10^{-3}	dB/K
$V_{de-em(DC)}$	DC voltage at decoupling capacitor	voltage dependent on VCO frequency; note 18	1.2	–	3.0	V
R_{AF}	output resistance	note 2	–	–	100	Ω
V_{AF}	DC output voltage		–	2.3	–	V
$I_{sink(max)(AF)}$	maximum AC and DC output sink current		–	–	0.5	mA
$I_{source(max)(AF)}$	maximum AC and DC output source current		–	–	0.5	mA
$B_{AF(-3dB)}$	–3 dB audio frequency bandwidth	without de-emphasis capacitor	100	125	–	kHz
THD	total harmonic distortion	27 kHz (54% FM deviation)	–	0.2	0.5	%
S/N_W	weighted signal-to-noise ratio	FM-PLL only; with 50 μ s de-emphasis; 27 kHz (54% FM deviation); "CCIR 468-4"	55	60	–	dB
$\alpha_{sc(rms)}$	residual sound carrier (RMS value)	fundamental wave and harmonics	–	–	75	mV
α_{AF}	mute attenuation of AF signal	B/G and L standard	70	75	–	dB
ΔV_{AF}	DC jump voltage of AF output terminal for switching AF output to mute state and vice versa	FM-PLL in lock mode	–	± 50	± 150	mV
PSRR	power supply ripple rejection at pin AF	$R_x = 0 \Omega$; $f = 70$ Hz; see Figs 13 and 15	20	26	–	dB

Single/multistandard VIF/SIF-PLL and
FM-PLL/AM demodulators

TDA9817; TDA9818

SYMBOL	PARAMETER	CONDITIONS	MIN.	TYP.	MAX.	UNIT
Single reference QSS AF performance for FM operation (B/G standard); see Table 1; notes 19, 20 and 21						
S/N _W	weighted signal-to-noise ratio	pc/sc1 ratio at pins VIF1 and VIF2; 27 kHz (54% FM deviation); "CCIR 468-4"	40	–	–	dB
		black picture	53	58	–	dB
		white picture	50	55	–	dB
		6 kHz sine wave (black-to-white modulation)	42	48	–	dB
		sound carrier subharmonics; f = 2.75 MHz ±3 kHz	45	51	–	dB
Intercarrier AF performance for FM operation (standard B/G); see Table 1; notes 19, 20 and 22						
S/N _W	weighted signal-to-noise ratio	pc/sc1 ratio at pins VIF1 and VIF2; 27 kHz (54% FM deviation); "CCIR 468-4"	27	–	–	dB
		black picture	47	51	–	dB
		white picture	47	51	–	dB
		6 kHz sine wave (black-to-white modulation)	40	46	–	dB
		sound carrier subharmonics; f = 2.75 MHz ±3 kHz	35	39	–	dB
AM operation (L standard; pin AF); note 23						
V _{o(AF)(rms)}	AF output signal voltage (RMS value)	54% modulation	400	500	600	mV
THD	total harmonic distortion	54% modulation	–	0.5	1.0	%
B _{AF(-3dB)}	–3 dB AF bandwidth		100	125	–	kHz
S/N _W	weighted signal-to-noise ratio	"CCIR 468-4"	47	53	–	dB
V _{AF}	DC potential voltage		–	2.3	–	V
PSRR	power supply ripple rejection at pin AF	see Fig.13	20	26	–	dB
Switching level for standard switch (pin STD)						
V _{logic}	DC potential for logic HIGH or pin not connected	B/G standard	2.8	–	V _P	V
	DC potential for logic LOW	L/L accent standard	0	–	0.8	V
I _{IL}	LOW level input current	V _i = 0 V	190	250	310	μA

Single/multistandard VIF/SIF-PLL and FM-PLL/AM demodulators

TDA9817; TDA9818

Notes

1. Values of video and sound parameters are decreased at $V_P = 4.5$ V.
2. This parameter is not tested during production and is only given as an application information for designing the television receiver.
3. Loop bandwidth $BL = 70$ kHz (natural frequency $f_n = 12$ kHz; damping factor $d \approx 3$; calculated with sync level within gain control range). Resonance circuit of VCO: $Q_0 > 50$; $C_{ext} = 8.2$ pF ± 0.25 pF; $C_{int} \approx 8.5$ pF (loop voltage approximately 2.7 V).
4. Temperature coefficient of external LC circuit is equal to zero.
5. $V_{i(VIF)(rms)} = 10$ mV; $\Delta f = 1$ MHz (VCO frequency offset related to picture carrier frequency); white picture video modulation.
6. VIF signal for nominal video signal.
7. The leakage current of the AGC capacitor should not exceed 1 μ A at B/G standard, respectively 10 nA current at L standard. Larger currents will increase the tilt.
8. S/N is the ratio of black-to-white amplitude to the black level noise voltage (RMS value, pin CVBS). $B = 5$ MHz weighted in accordance with "CCIR 567".
9. The intermodulation figures are defined:

$$\alpha_{1.1} = 20 \log\left(\frac{V_o \text{ at 4.4 MHz}}{V_o \text{ at 1.1 MHz}}\right) + 3.6 \text{ dB}; \alpha_{1.1} \text{ value at 1.1 MHz referenced to black/white signal;}$$

$$\alpha_{3.3} = 20 \log\left(\frac{V_o \text{ at 4.4 MHz}}{V_o \text{ at 3.3 MHz}}\right); \alpha_{3.3} \text{ value at 3.3 MHz referenced to colour carrier.}$$

10. Measurements taken with SAW filter K3953 (sound carrier suppression: 40 dB); loop bandwidth $BL = 70$ kHz:
 - a) Modulation VSB; sound carrier off; $f_{video} > 0.5$ MHz.
 - b) Sound carrier on; SIF SAW filter K9453; $f_{video} = 10$ kHz to 10 MHz.
11. Response speed valid for a VIF input level range of 200 μ V up to 70 mV.
12. To match the AFC output signal to different tuning systems a current source output is provided. The test circuit is given in Fig.9. The AFC-steepness can be changed by the resistors at pin AFC.
13. Depending on the ratio $\Delta C/C_0$ of the LC resonant circuit of VCO ($Q_0 > 50$; note 3; $C_0 = C_{int} + C_{ext}$).
14. Source impedance: 2.3 k Ω in parallel to 12 pF (SAW filter); $f_{IF} = 38.9$ MHz.
15. Without using an SIF SAW filter the mixer can be switched to intercarrier mode by connecting pin SIF1 and/or pin SIF2 to ground. In this mode the SIF passes the VIF SAW filter and IF intercarrier levels are depending on the sound shelf of the VIF SAW filter. The intercarrier output signal at pin QSS can be calculated by the following formula taking into account the video output signal at pin CVBS ($V_{o(CVBS)(p-p)} = 1.1$ V typical) as a reference:

$$V_{o(rms)} = 1.1 \text{ V}(p-p) \times \frac{1}{2\sqrt{2}} \times 10^{\frac{V_{i(sc)}(dB) + 6 \text{ dB} \pm 3 \text{ dB}}{20}} \quad \text{where:}$$

- a) $\frac{1}{2\sqrt{2}}$ = correction term for RMS value
- b) $\frac{V_{i(sc)}}{V_{i(pc)}}(dB)$ = sound-to-picture carrier ratio at VIF inputs in dB
- c) 6 dB = correction term of internal circuitry
- d) ± 3 dB = tolerance of video output and intercarrier output amplitude $V_{o(rms)}$

Single/multistandard VIF/SIF-PLL and FM-PLL/AM demodulators

TDA9817; TDA9818

e) Example for SAW filter G1962: sound shelf value = 20 dB,

$$\frac{V_{i(sc)}}{V_{i(pc)}} = -27 \text{ dB} \Rightarrow V_{o(rms)} = 32 \text{ mV (typical value)}$$

16. Input level for second IF from an external generator with 50 Ω source impedance. AC-coupled with 10 nF capacitor, $f_{mod} = 1 \text{ kHz}$, 27 kHz (54% FM deviation) of audio references. A VIF/SIF input signal is not permitted. Pins C_{VAGC} and C_{SAGC} have to be connected to positive supply voltage for minimum IF gain. S/N and THD measurements are taken at 50 μs de-emphasis at pin V_{de-em} (modulator pre-emphasis has to be activated). The FM demodulator steepness $\Delta V_{o(AF)}/\Delta f_{AF}$ is positive.
 - a) Second IF input level 10 mV (RMS value).
17. Measured with an FM deviation of 27 kHz the typical AF output signal is 500 mV (RMS) ($R_x = 0 \Omega$). By using $R_x = 470 \Omega$ the AF output signal is attenuated by 6 dB [250 mV (RMS)]. For handling a frequency deviation of more than 53 kHz the AF output signal has to be reduced by using R_x in order to avoid clipping (THD < 1.5%). For an FM deviation up to 100 kHz an attenuation of 6 dB is recommended with $R_x = 470 \Omega$.
18. The leakage current of the decoupling capacitor (2.2 μF) should not exceed 1 μA .
19. For all S/N measurements the used vision IF modulator has to meet the following specifications:
 - a) Incidental phase modulation for black-to-white jump less than 0.5 degrees
 - b) QSS AF performance, measured with the television demodulator AMF2 (audio output, weighted S/N ratio) better than 60 dB (deviation 27 kHz) for 6 kHz sine wave black-to-white video modulation
 - c) Picture-to-sound carrier ratio; $pc/sc1 = 13 \text{ dB}$ (transmitter).
20. The $pc/sc1$ ratio is calculated as the addition of TV transmitter $pc/sc1$ ratio and SAW filter $pc/sc1$ ratio. This $pc/sc1$ ratio is necessary to achieve the S/N_W values as noted. A different $pc/sc1$ ratio will change these values.
21. Measurements taken with SAW filter K3953 for vision IF (suppressed sound carrier) and K9453 for sound IF (suppressed picture carrier). Input level $V_{i(SIF)(rms)} = 10 \text{ mV}$, 27 kHz (54% FM deviation).
22. Measurements taken with SAW filter G1962 (sound shelf: 20 dB) for vision and sound IF. Pin SIF1 and/or pin SIF2 has to be connected to ground for switching the single reference QSS mixer to intercarrier mode.
23. Measurements taken with SAW filter K9453 (Siemens) for AM sound IF (suppressed picture carrier).

Table 1 Input frequencies and carrier ratios

DESCRIPTION	SYMBOL	B/G STANDARD	M/N STANDARD	L STANDARD	L ACCENT STANDARD	UNIT
picture or IF carrier	f_{pc} or f_{IF}	38.9	45.75/58.75	38.9	33.9	MHz
sound carrier	f_{sc1}	33.4	41.25/54.25	32.4	40.4	MHz
	f_{sc2}	33.158	–	–	–	MHz
picture-to-sound carrier	sc1	13	7	10	10	dB
	sc2	20	–	–	–	dB

Single/multistandard VIF/SIF-PLL and FM-PLL/AM demodulators

TDA9817; TDA9818

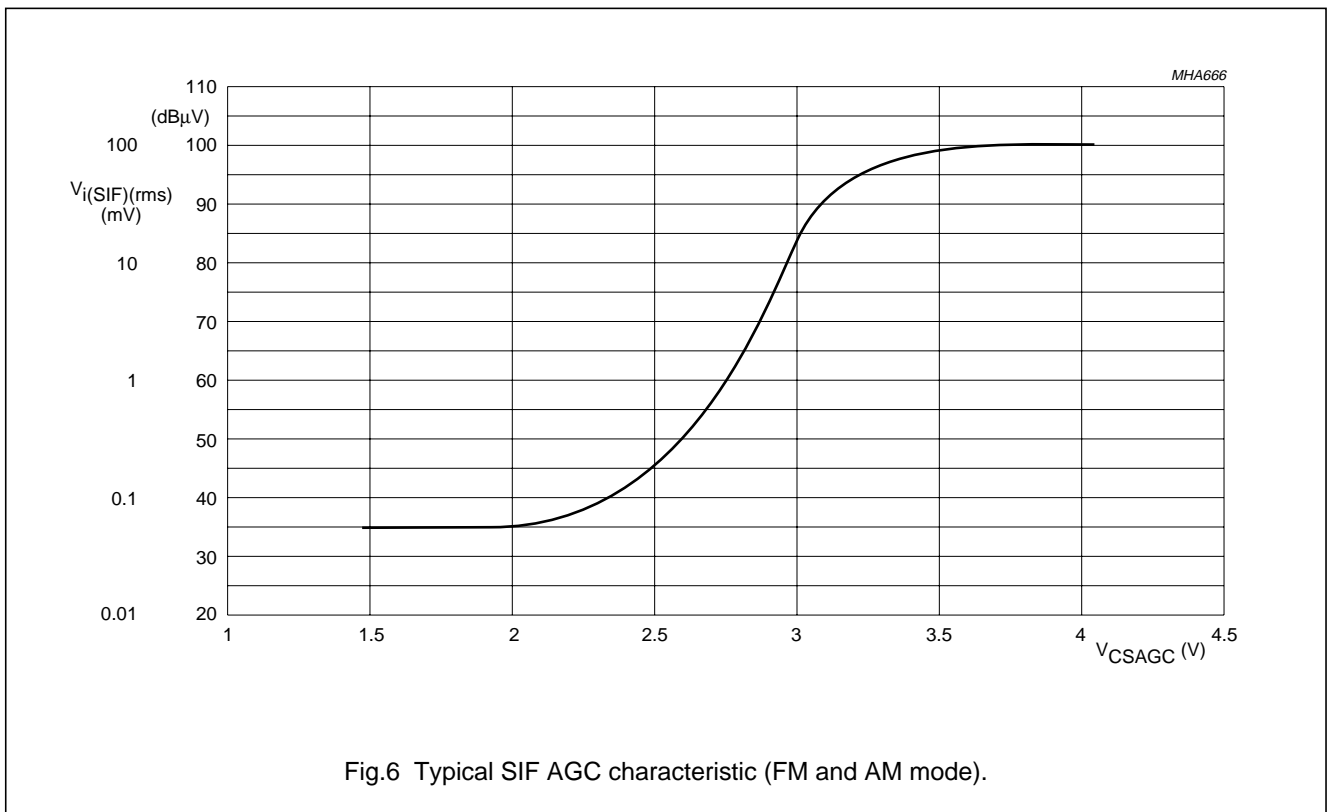
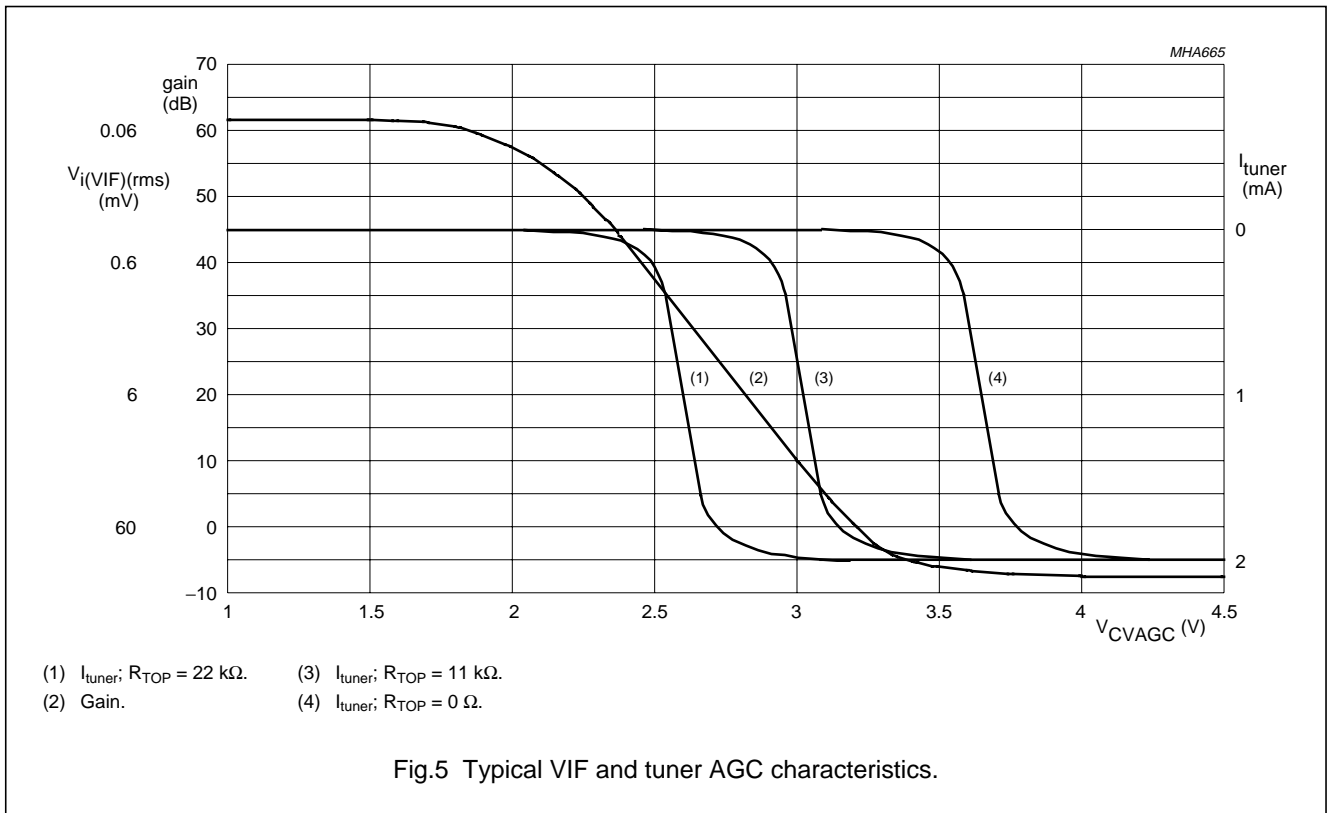

Single/multistandard VIF/SIF-PLL and FM-PLL/AM demodulators

TDA9817; TDA9818

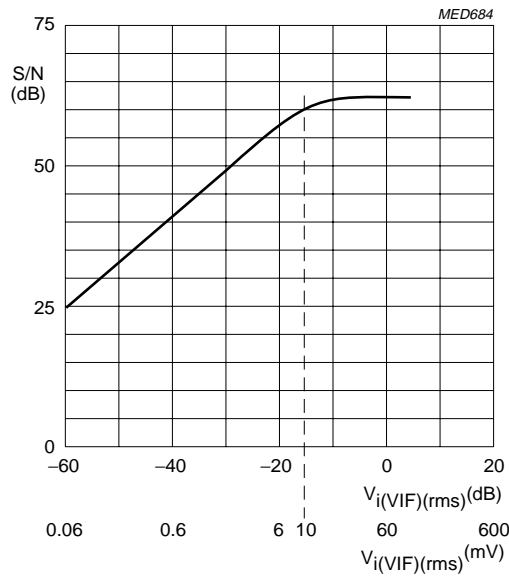
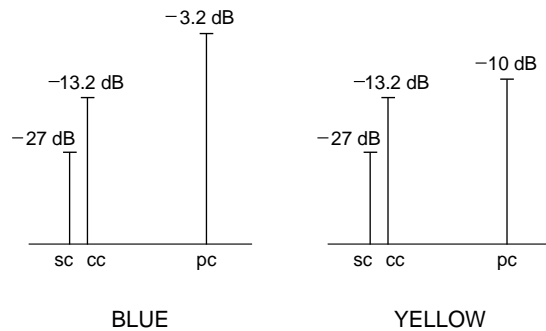

Fig.7 Typical signal-to-noise ratio as a function of IF input voltage.



sc = sound carrier, with respect to sync level.
 cc = chrominance carrier, with respect to sync level.
 pc = picture carrier, with respect to sync level.
 The sound carrier levels are taking into account a sound shelf attenuation of 20 dB (SAW filter G1962).

Fig.8 Input signal conditions.

Single/multistandard VIF/SIF-PLL and FM-PLL/AM demodulators

TDA9817; TDA9818

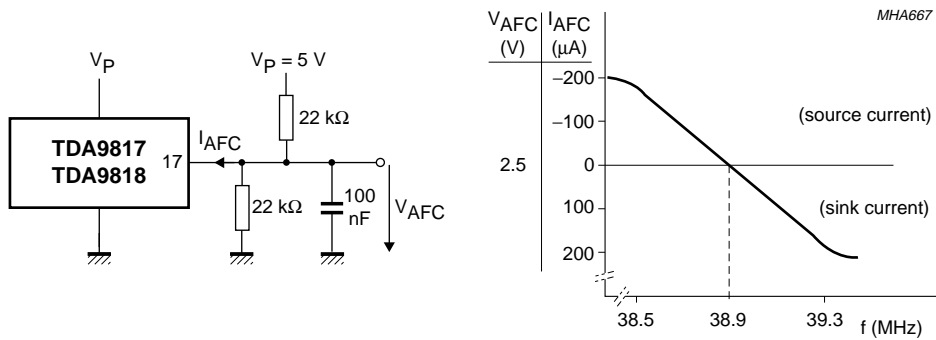

Fig.9 Measurement conditions and typical AFC characteristic.

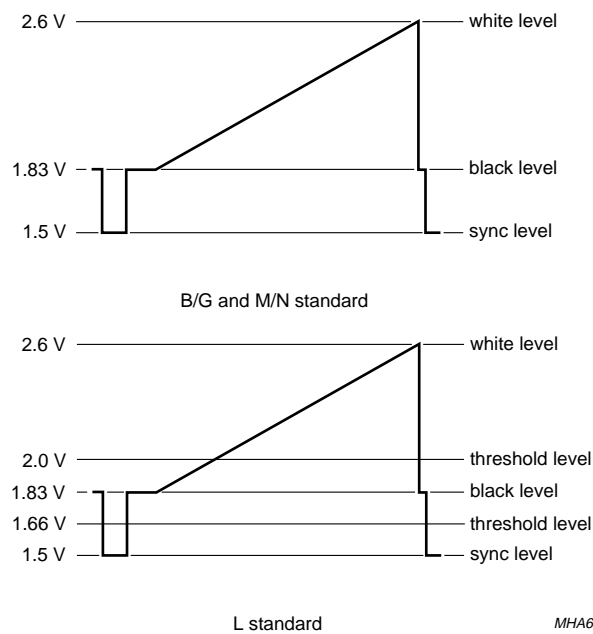
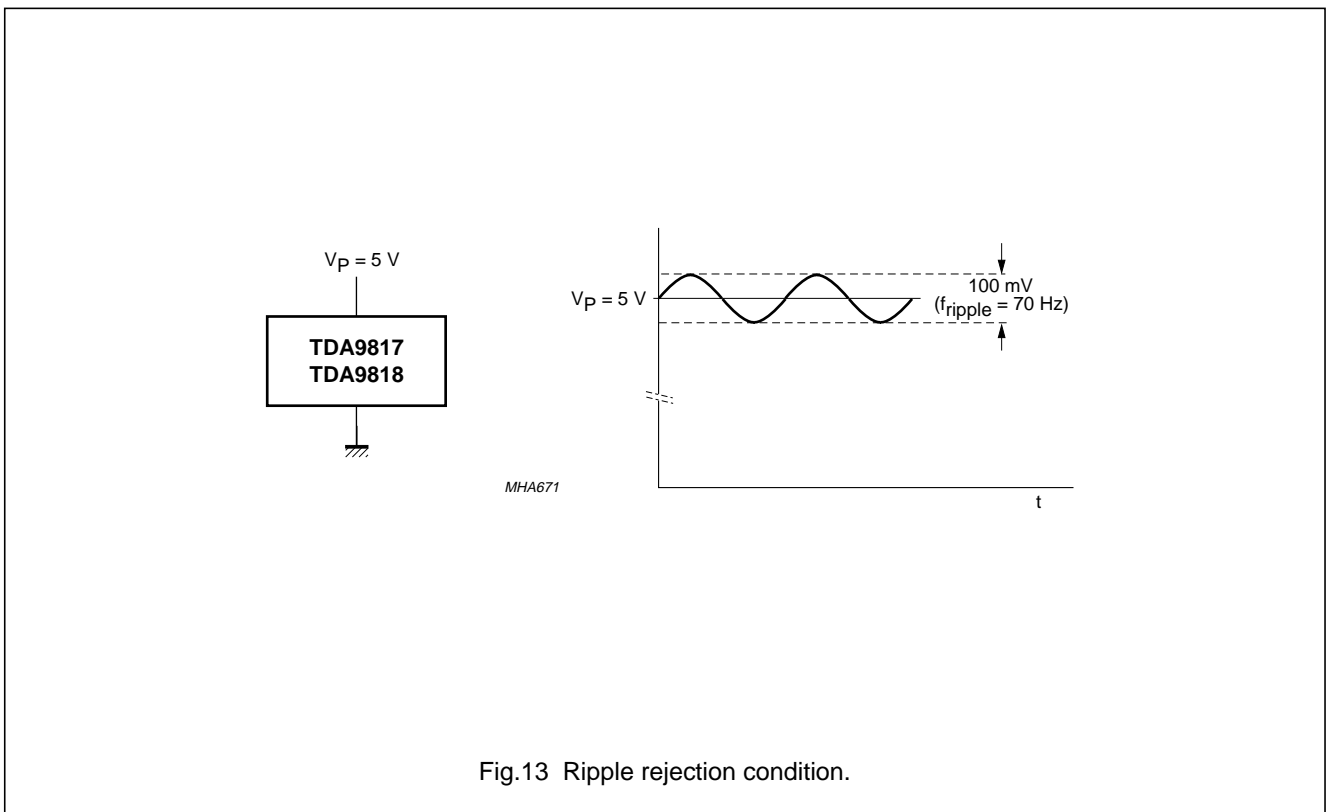
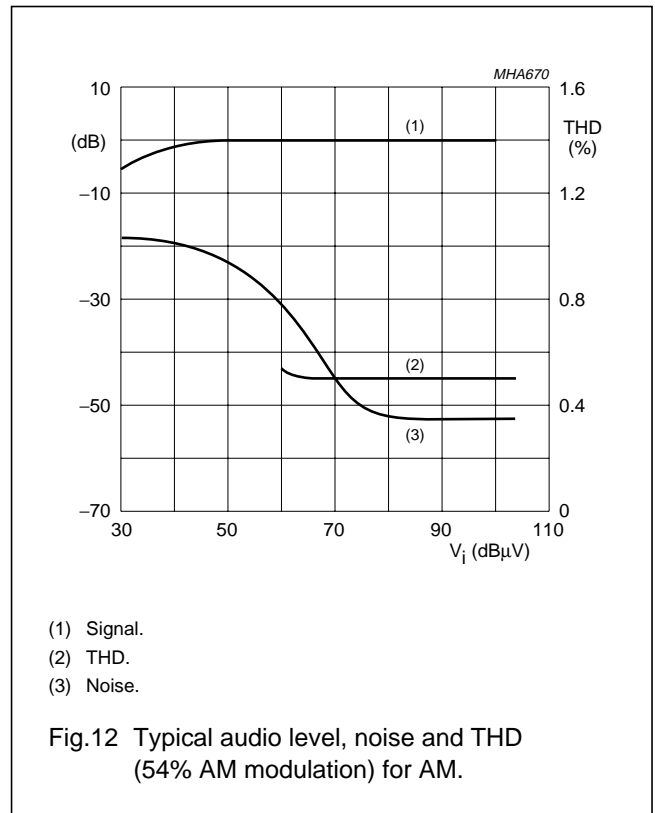
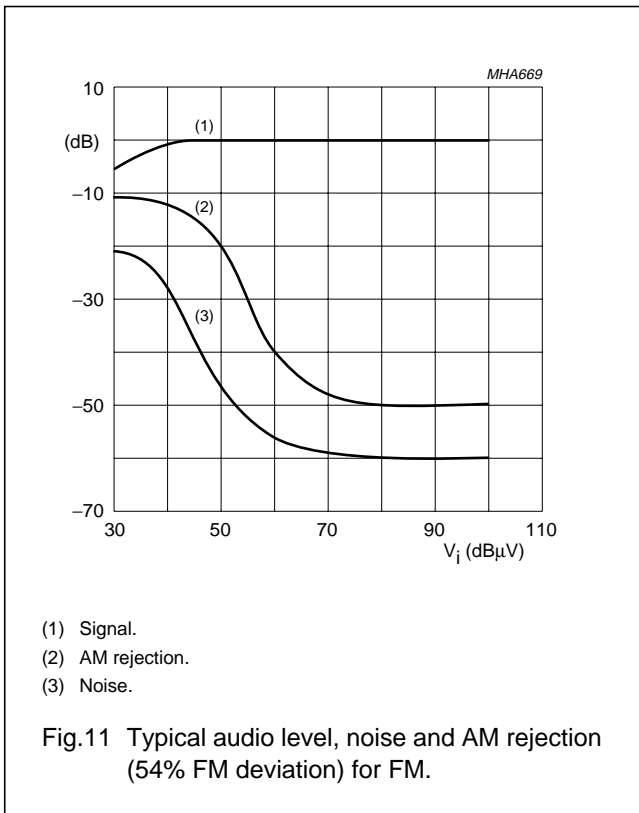

Fig.10 Typical video signal levels on output pin CVBS (sound carrier off).

Single/multistandard VIF/SIF-PLL and FM-PLL/AM demodulators

TDA9817; TDA9818



Single/multistandard VIF/SIF-PLL and FM-PLL/AM demodulators

TDA9817; TDA9818

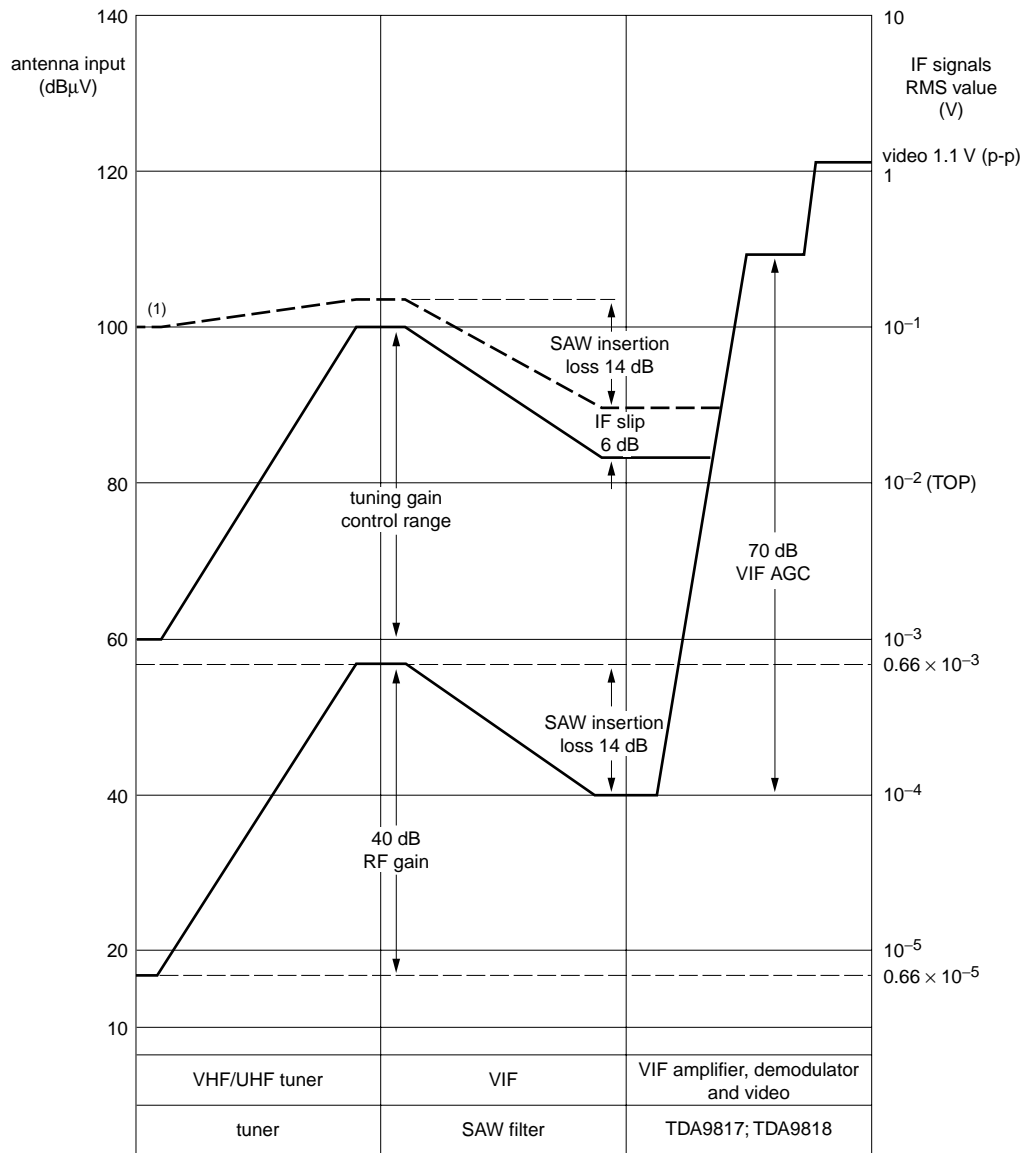

MHA672

(1) Depends on TOP.

Fig.14 Front end level diagram.

Single/multistandard VIF/SIF-PLL and FM-PLL/AM demodulators

TDA9817; TDA9818

INTERNAL CIRCUITRY

Table 2 Equivalent pin circuits and pin voltages

PIN NO.	PIN SYMBOL	DC VOLTAGE (V)	EQUIVALENT CIRCUIT (WITHOUT ESD PROTECTION CIRCUIT)
1 2	VIF1 VIF2	3.4 3.4	
3	STD ⁽¹⁾	0 to V _P	
4	C _{VAGC}	1.5 to 4.0	

Single/multistandard VIF/SIF-PLL and FM-PLL/AM demodulators

TDA9817; TDA9818

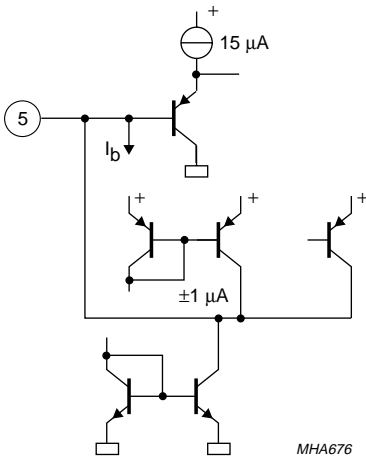
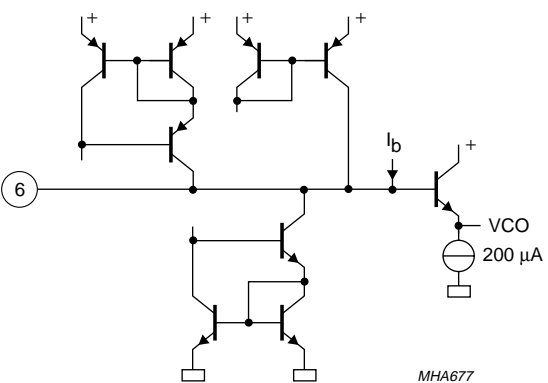
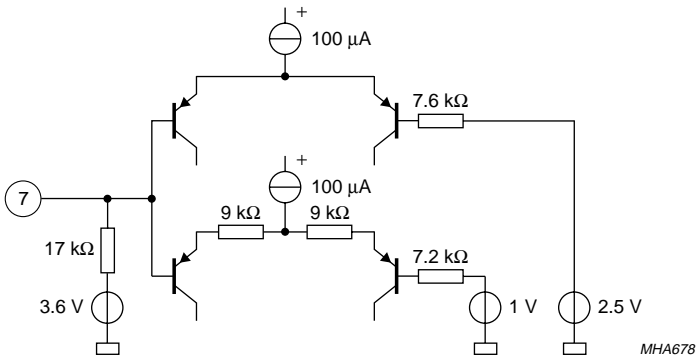
PIN NO.	PIN SYMBOL	DC VOLTAGE (V)	EQUIVALENT CIRCUIT (WITHOUT ESD PROTECTION CIRCUIT)
5	CSAGC	1.5 to 4.0	
6	PLL	1.5 to 4.0	
7	LADJ ⁽¹⁾	0 to V _P	

Single/multistandard VIF/SIF-PLL and FM-PLL/AM demodulators

TDA9817; TDA9818

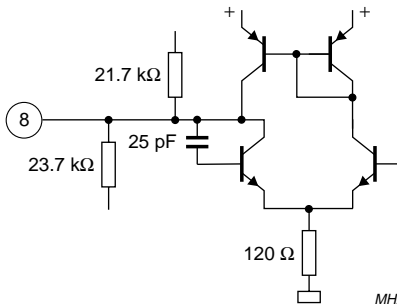
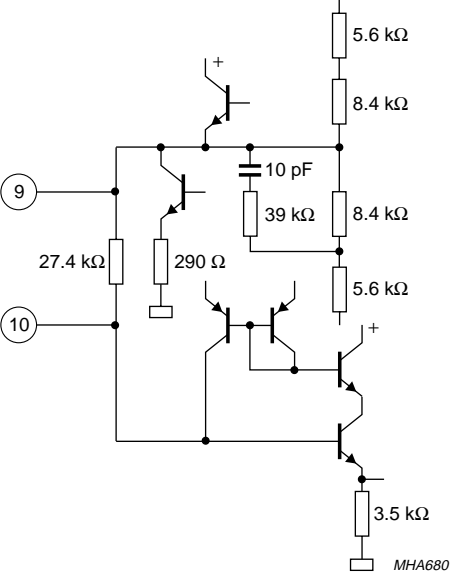
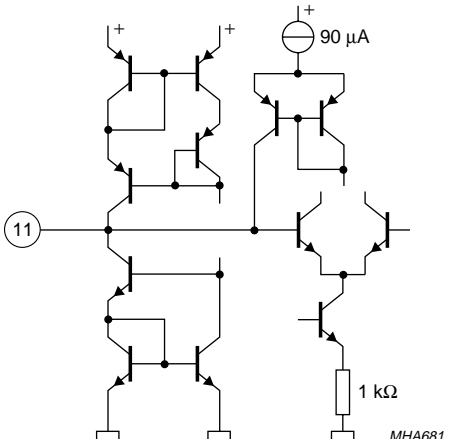
PIN NO.	PIN SYMBOL	DC VOLTAGE (V)	EQUIVALENT CIRCUIT (WITHOUT ESD PROTECTION CIRCUIT)
8	AF	2.3	
9	V_{de-em}	2.3	
10	C_{de-em}	2.3	
11	C_{DEC}	1.2 to 3.0	

Single/multistandard VIF/SIF-PLL and FM-PLL/AM demodulators

TDA9817; TDA9818

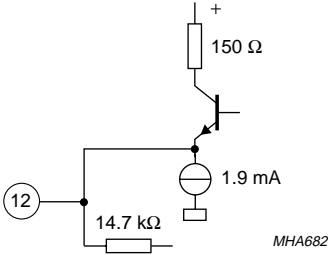
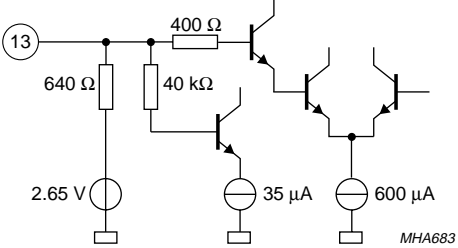
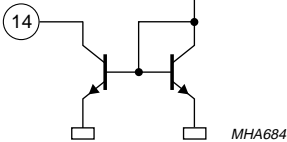
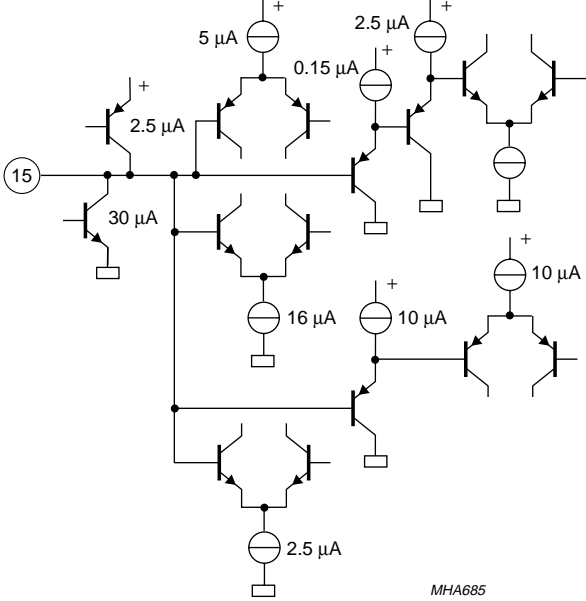
PIN NO.	PIN SYMBOL	DC VOLTAGE (V)	EQUIVALENT CIRCUIT (WITHOUT ESD PROTECTION CIRCUIT)
12	QSS	2.0	 <p>MHA682</p>
13	FM _{in}	2.65	 <p>MHA683</p>
14	TAGC	0 to 13.2	 <p>MHA684</p>
15	C _{BL} ⁽¹⁾	0 to 3.2	 <p>MHA685</p>

Single/multistandard VIF/SIF-PLL and FM-PLL/AM demodulators

TDA9817; TDA9818

PIN NO.	PIN SYMBOL	DC VOLTAGE (V)	EQUIVALENT CIRCUIT (WITHOUT ESD PROTECTION CIRCUIT)
16	CVBS	sync level: 1.5	
17	AFC	0.3 to $V_P - 0.3$	
18	VCO1	2.7	
19	VCO2	2.7	
20	GND	0	
21	V_P	V_P	

Single/multistandard VIF/SIF-PLL and FM-PLL/AM demodulators

TDA9817; TDA9818

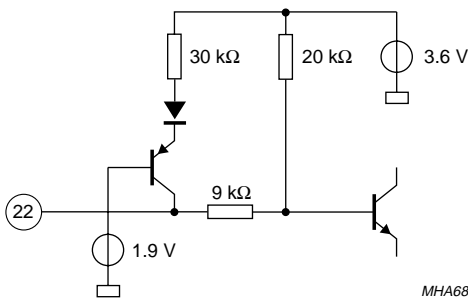
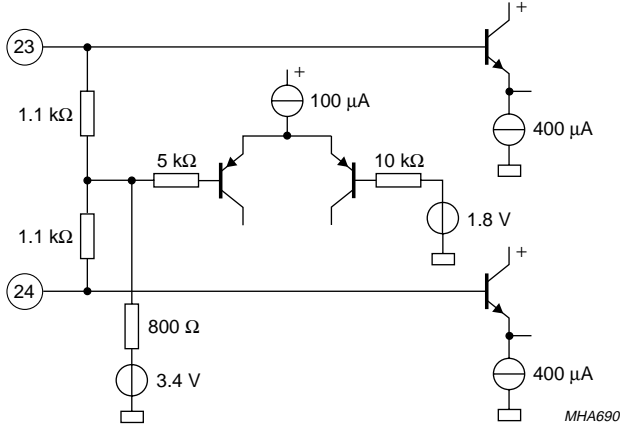
PIN NO.	PIN SYMBOL	DC VOLTAGE (V)	EQUIVALENT CIRCUIT (WITHOUT ESD PROTECTION CIRCUIT)
22	TOP	0 to 1.9	 <p style="text-align: right;"><i>MHA689</i></p>
23	SIF1	3.4	 <p style="text-align: right;"><i>MHA690</i></p>
24	SIF2	3.4	

Note

1. Not connected for TDA9817, TDA9817T and TD9817TS.

Single/multistandard VIF/SIF-PLL and FM-PLL/AM demodulators

TDA9817; TDA9818

TEST AND APPLICATION INFORMATION

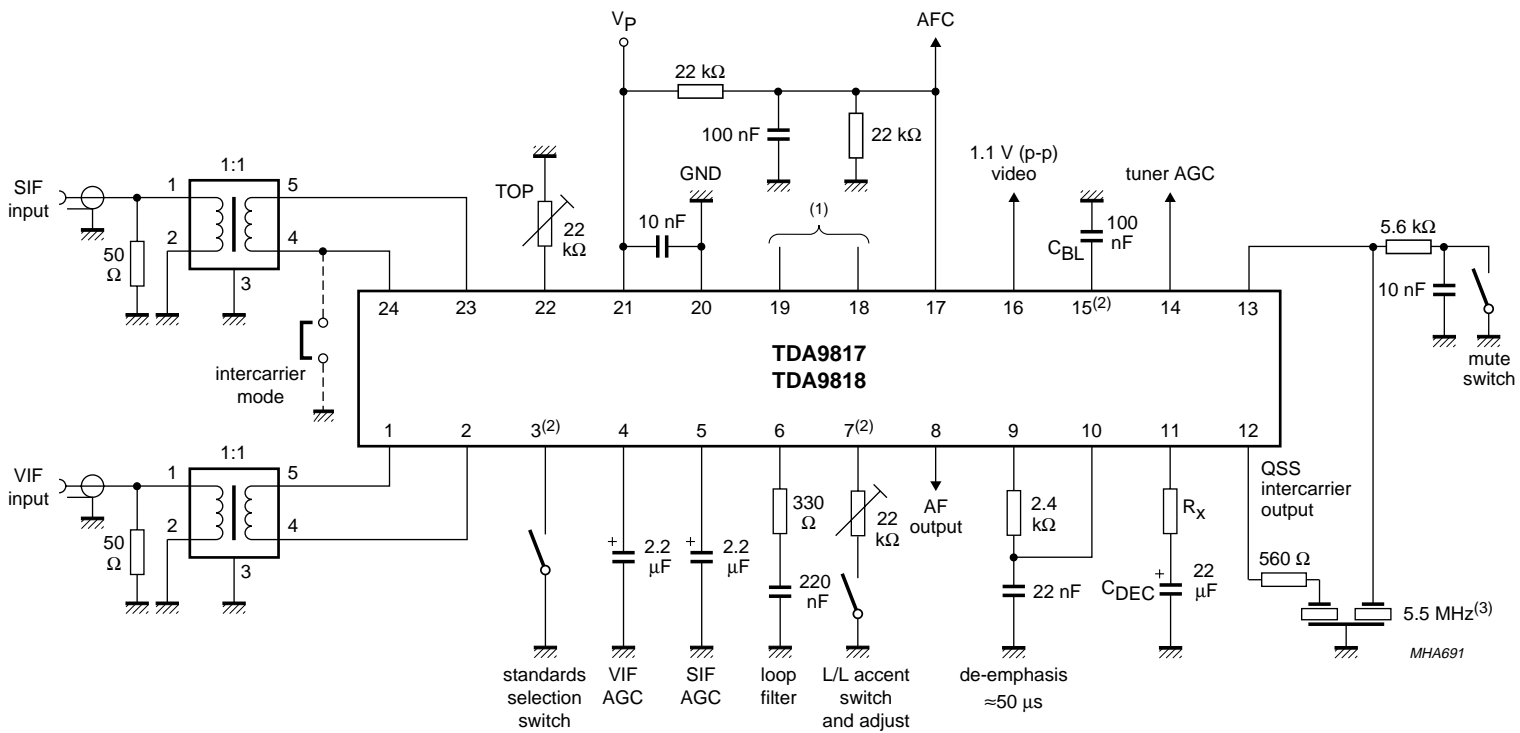

- (1) See Table 3.
- (2) Not connected for TDA9817, TDA9817T and TDA9817TS.
- (3) Depends on TV standard.

Fig.15 Test circuit.

Single/multistandard VIF/SIF-PLL and FM-PLL/AM demodulators

TDA9817; TDA9818

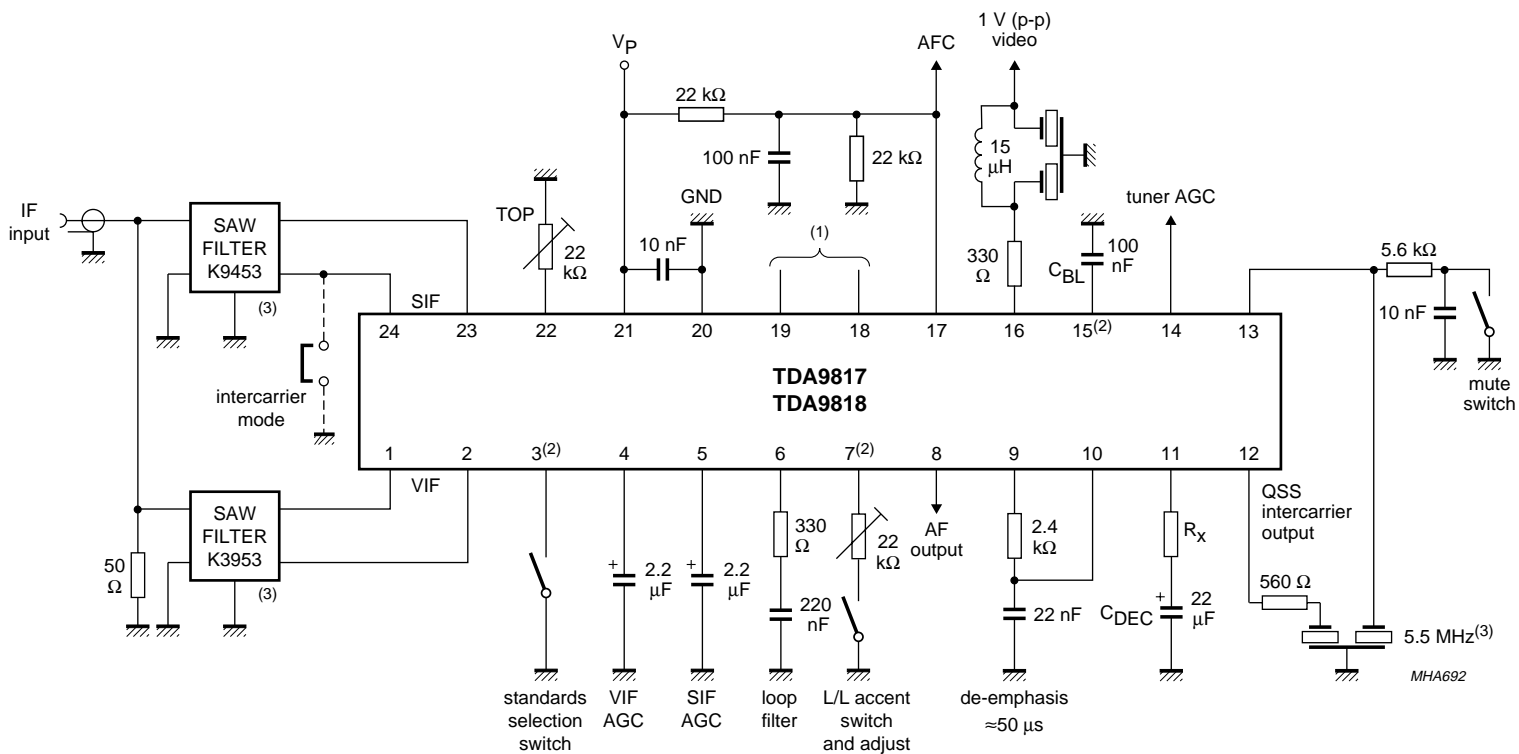

- (1) See Table 3.
- (2) Not connected for TDA9817, TDA9817T and TDA9817TS.
- (3) Depends on TV standard.

Fig.16 Application circuit.

Single/multistandard VIF/SIF-PLL and FM-PLL/AM demodulators

TDA9817; TDA9818

Table 3 Oscillator circuit for the different TV standards

PARAMETER	EUROPE	USA	JAPAN
IF frequency	38.9 MHz	45.75 MHz	58.75 MHz
VCO frequency	77.8 MHz	91.5 MHz	117.5 MHz
Oscillator circuit			
e.g. Toko coil	5KM 369SNS-2010Z	5KMC V369SCS-2370Z	MC 139 NE545SNAS100108
Philips ceramic capacitor	2222 632 51828	inside of coil	15 pF SMD; size = 0805

Single/multistandard VIF/SIF-PLL and FM-PLL/AM demodulators

TDA9817; TDA9818

PACKAGE OUTLINES

SDIP24: plastic shrink dual in-line package; 24 leads (400 mil)

SOT234-1

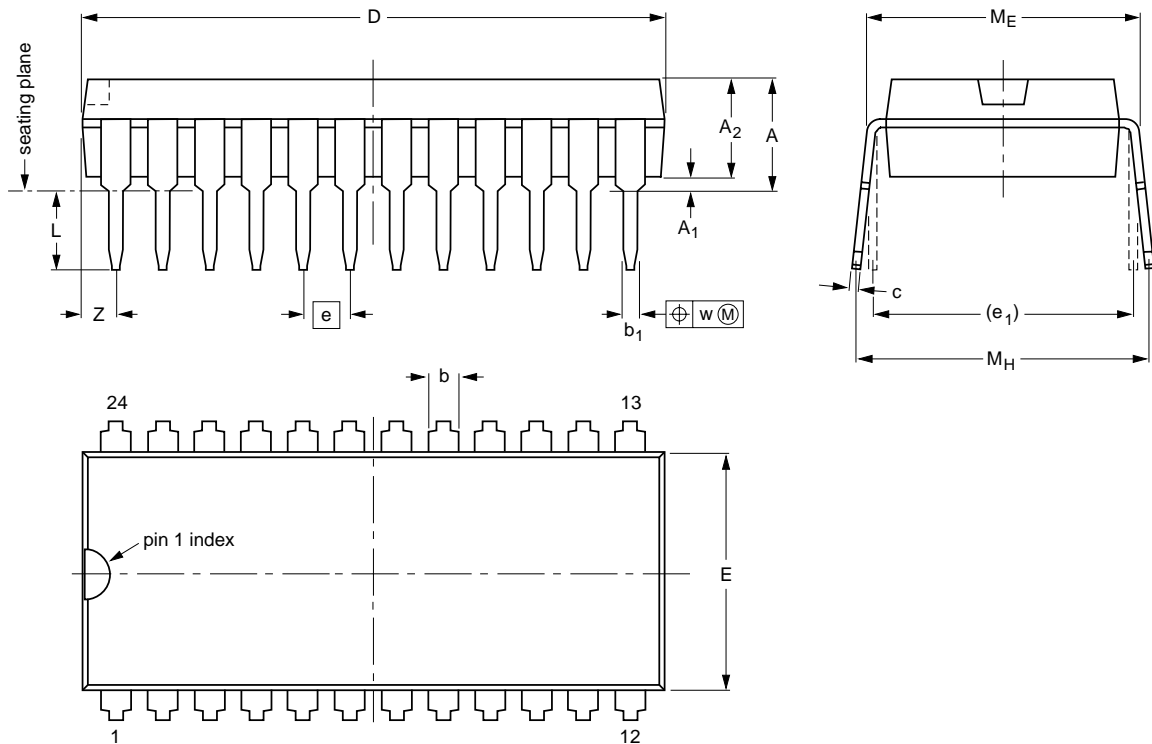

DIMENSIONS (mm are the original dimensions)

UNIT	A max.	A ₁ min.	A ₂ max.	b	b ₁	c	D ⁽¹⁾	E ⁽¹⁾	e	e ₁	L	M _E	M _H	w	Z ⁽¹⁾ max.
mm	4.7	0.51	3.8	1.3 0.8	0.53 0.40	0.32 0.23	22.3 21.4	9.1 8.7	1.778	10.16	3.2 2.8	10.7 10.2	12.2 10.5	0.18	1.6

Note

1. Plastic or metal protrusions of 0.25 mm maximum per side are not included.

OUTLINE VERSION	REFERENCES				EUROPEAN PROJECTION	ISSUE DATE
	IEC	JEDEC	EIAJ			
SOT234-1						92-11-17 95-02-04

Single/multistandard VIF/SIF-PLL and FM-PLL/AM demodulators

TDA9817; TDA9818

SO24: plastic small outline package; 24 leads; body width 7.5 mm

SOT137-1

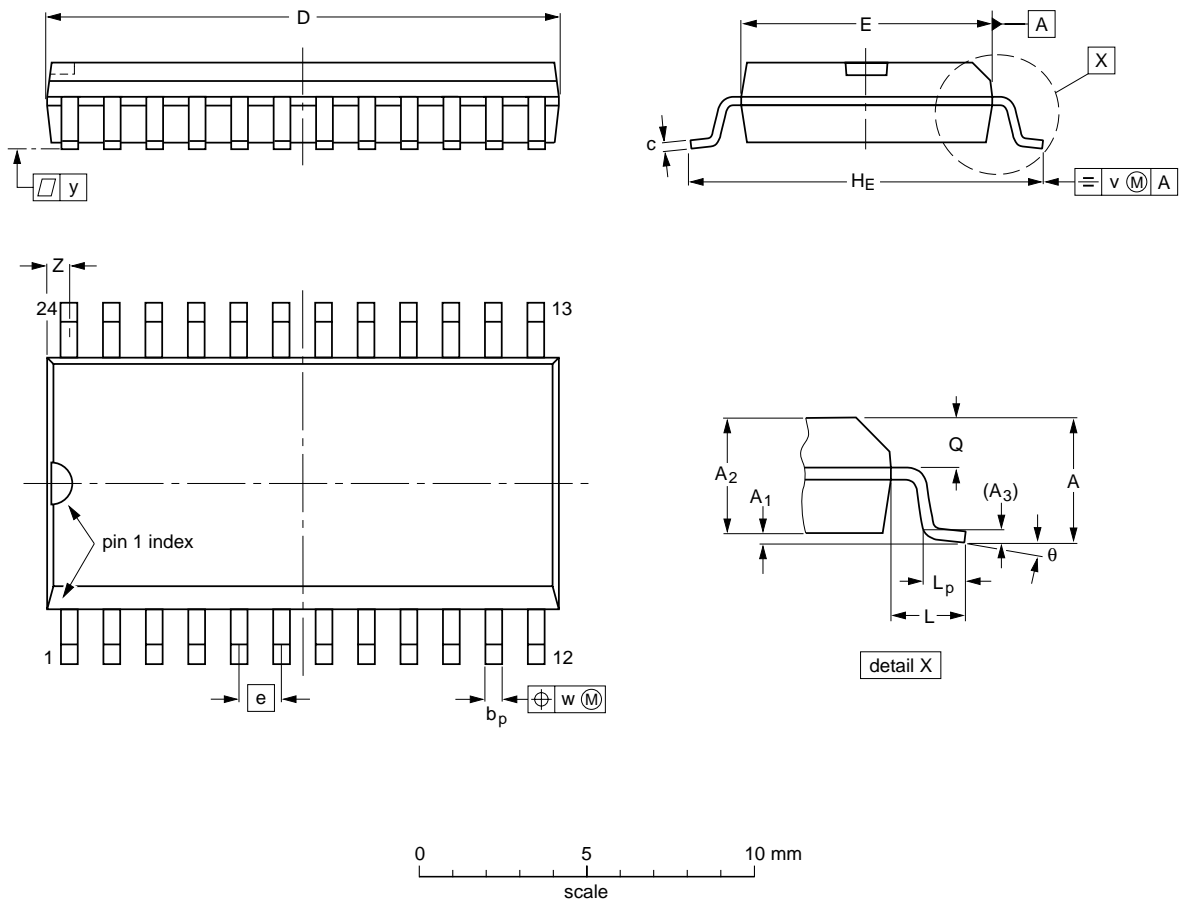

DIMENSIONS (inch dimensions are derived from the original mm dimensions)

UNIT	A max.	A ₁	A ₂	A ₃	b _p	c	D ⁽¹⁾	E ⁽¹⁾	e	H _E	L	L _p	Q	v	w	y	Z ⁽¹⁾	θ
mm	2.65	0.30 0.10	2.45 2.25	0.25	0.49 0.36	0.32 0.23	15.6 15.2	7.6 7.4	1.27	10.65 10.00	1.4	1.1 0.4	1.1 1.0	0.25	0.25	0.1	0.9 0.4	8° 0°
inches	0.10	0.012 0.004	0.096 0.089	0.01	0.019 0.014	0.013 0.009	0.61 0.60	0.30 0.29	0.050	0.419 0.394	0.055	0.043 0.016	0.043 0.039	0.01	0.01	0.004	0.035 0.016	

Note

1. Plastic or metal protrusions of 0.15 mm maximum per side are not included.

OUTLINE VERSION	REFERENCES				EUROPEAN PROJECTION	ISSUE DATE
	IEC	JEDEC	EIAJ			
SOT137-1	075E05	MS-013				97-05-22 99-12-27

Single/multistandard VIF/SIF-PLL and FM-PLL/AM demodulators

TDA9817; TDA9818

SSOP24: plastic shrink small outline package; 24 leads; body width 5.3 mm

SOT340-1

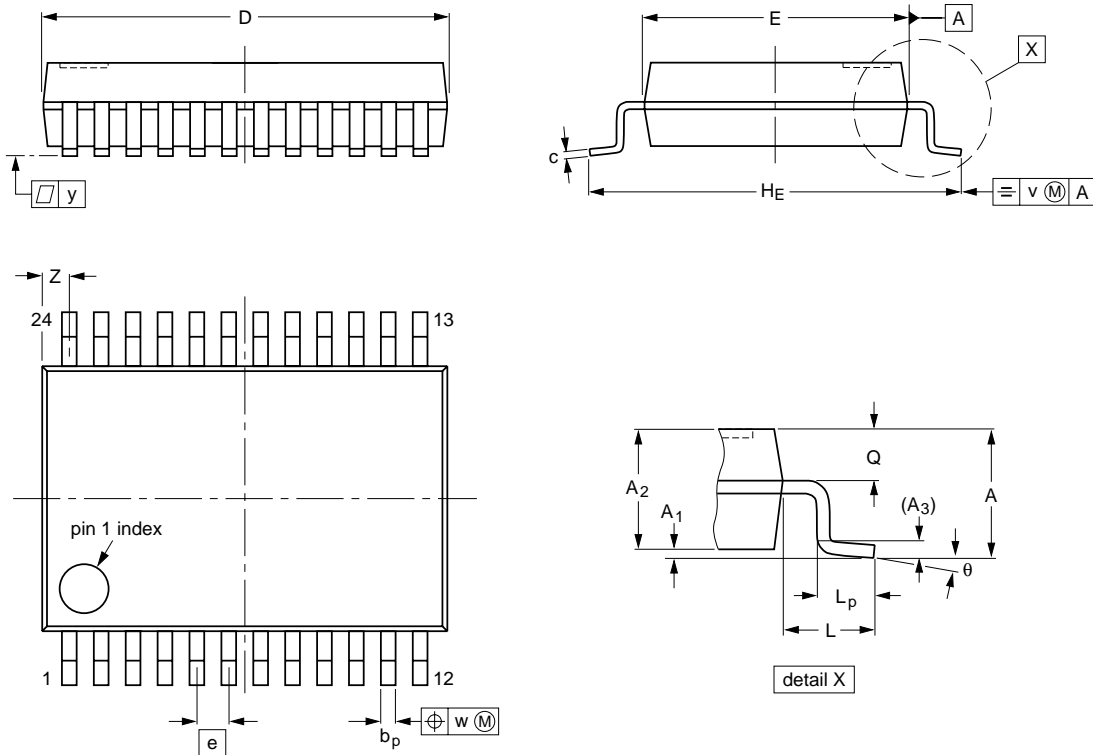

DIMENSIONS (mm are the original dimensions)

UNIT	A max.	A ₁	A ₂	A ₃	b _p	c	D ⁽¹⁾	E ⁽¹⁾	e	H _E	L	L _p	Q	v	w	y	z ⁽¹⁾	θ
mm	2.0	0.21 0.05	1.80 1.65	0.25	0.38 0.25	0.20 0.09	8.4 8.0	5.4 5.2	0.65	7.9 7.6	1.25	1.03 0.63	0.9 0.7	0.2	0.13	0.1	0.8 0.4	8° 0°

Note

1. Plastic or metal protrusions of 0.20 mm maximum per side are not included.

OUTLINE VERSION	REFERENCES				EUROPEAN PROJECTION	ISSUE DATE
	IEC	JEDEC	EIAJ			
SOT340-1		MO-150				95-02-04 99-12-27

Single/multistandard VIF/SIF-PLL and FM-PLL/AM demodulators

TDA9817; TDA9818

SOLDERING

Introduction

This text gives a very brief insight to a complex technology. A more in-depth account of soldering ICs can be found in our *"Data Handbook IC26; Integrated Circuit Packages"* (document order number 9398 652 90011).

There is no soldering method that is ideal for all IC packages. Wave soldering is often preferred when through-hole and surface mount components are mixed on one printed-circuit board. Wave soldering can still be used for certain surface mount ICs, but it is not suitable for fine pitch SMDs. In these situations reflow soldering is recommended.

Through-hole mount packages

SOLDERING BY DIPPING OR BY SOLDER WAVE

The maximum permissible temperature of the solder is 260 °C; solder at this temperature must not be in contact with the joints for more than 5 seconds. The total contact time of successive solder waves must not exceed 5 seconds.

The device may be mounted up to the seating plane, but the temperature of the plastic body must not exceed the specified maximum storage temperature ($T_{stg(max)}$). If the printed-circuit board has been pre-heated, forced cooling may be necessary immediately after soldering to keep the temperature within the permissible limit.

MANUAL SOLDERING

Apply the soldering iron (24 V or less) to the lead(s) of the package, either below the seating plane or not more than 2 mm above it. If the temperature of the soldering iron bit is less than 300 °C it may remain in contact for up to 10 seconds. If the bit temperature is between 300 and 400 °C, contact may be up to 5 seconds.

Surface mount packages

REFLOW SOLDERING

Reflow soldering requires solder paste (a suspension of fine solder particles, flux and binding agent) to be applied to the printed-circuit board by screen printing, stencilling or pressure-syringe dispensing before package placement.

Several methods exist for reflowing; for example, convection or convection/infrared heating in a conveyor type oven. Throughput times (preheating, soldering and cooling) vary between 100 and 200 seconds depending on heating method.

Typical reflow peak temperatures range from 215 to 250 °C. The top-surface temperature of the packages should preferably be kept below 220 °C for thick/large packages, and below 235 °C for small/thin packages.

WAVE SOLDERING

Conventional single wave soldering is not recommended for surface mount devices (SMDs) or printed-circuit boards with a high component density, as solder bridging and non-wetting can present major problems.

To overcome these problems the double-wave soldering method was specifically developed.

If wave soldering is used the following conditions must be observed for optimal results:

- Use a double-wave soldering method comprising a turbulent wave with high upward pressure followed by a smooth laminar wave.
- For packages with leads on two sides and a pitch (e):
 - larger than or equal to 1.27 mm, the footprint longitudinal axis is **preferred** to be parallel to the transport direction of the printed-circuit board;
 - smaller than 1.27 mm, the footprint longitudinal axis **must** be parallel to the transport direction of the printed-circuit board.

The footprint must incorporate solder thieves at the downstream end.

- For packages with leads on four sides, the footprint must be placed at a 45° angle to the transport direction of the printed-circuit board. The footprint must incorporate solder thieves downstream and at the side corners.

During placement and before soldering, the package must be fixed with a droplet of adhesive. The adhesive can be applied by screen printing, pin transfer or syringe dispensing. The package can be soldered after the adhesive is cured.

Typical dwell time is 4 seconds at 250 °C.

A mildly-activated flux will eliminate the need for removal of corrosive residues in most applications.

MANUAL SOLDERING

Fix the component by first soldering two diagonally-opposite end leads. Use a low voltage (24 V or less) soldering iron applied to the flat part of the lead. Contact time must be limited to 10 seconds at up to 300 °C. When using a dedicated tool, all other leads can be soldered in one operation within 2 to 5 seconds between 270 and 320 °C.

Single/multistandard VIF/SIF-PLL and FM-PLL/AM demodulators

TDA9817; TDA9818

Suitability of IC packages for wave, reflow and dipping soldering methods

MOUNTING	PACKAGE	SOLDERING METHOD		
		WAVE	REFLOW ⁽¹⁾	DIPPING
Through-hole mount	DBS, DIP, HDIP, SDIP, SIL	suitable ⁽²⁾	–	suitable
Surface mount	BGA, HBGA, LFBGA, SQFP, TFBGA	not suitable	suitable	–
	HBCC, HLQFP, HSQFP, HSOP, HTQFP, HTSSOP, HVQFN, SMS	not suitable ⁽³⁾	suitable	–
	PLCC ⁽⁴⁾ , SO, SOJ	suitable	suitable	–
	LQFP, QFP, TQFP	not recommended ⁽⁴⁾⁽⁵⁾	suitable	–
	SSOP, TSSOP, VSO	not recommended ⁽⁶⁾	suitable	–

Notes

1. All surface mount (SMD) packages are moisture sensitive. Depending upon the moisture content, the maximum temperature (with respect to time) and body size of the package, there is a risk that internal or external package cracks may occur due to vaporization of the moisture in them (the so called popcorn effect). For details, refer to the Drypack information in the “Data Handbook IC26; Integrated Circuit Packages; Section: Packing Methods”.
2. For SDIP packages, the longitudinal axis must be parallel to the transport direction of the printed-circuit board.
3. These packages are not suitable for wave soldering as a solder joint between the printed-circuit board and heatsink (at bottom version) can not be achieved, and as solder may stick to the heatsink (on top version).
4. If wave soldering is considered, then the package must be placed at a 45° angle to the solder wave direction. The package footprint must incorporate solder thieves downstream and at the side corners.
5. Wave soldering is only suitable for LQFP, QFP and TQFP packages with a pitch (e) equal to or larger than 0.8 mm; it is definitely not suitable for packages with a pitch (e) equal to or smaller than 0.65 mm.
6. Wave soldering is only suitable for SSOP and TSSOP packages with a pitch (e) equal to or larger than 0.65 mm; it is definitely not suitable for packages with a pitch (e) equal to or smaller than 0.5 mm.

Single/multistandard VIF/SIF-PLL and FM-PLL/AM demodulators

TDA9817; TDA9818

DATA SHEET STATUS

DATA SHEET STATUS ⁽¹⁾	PRODUCT STATUS ⁽²⁾	DEFINITIONS
Objective data	Development	This data sheet contains data from the objective specification for product development. Philips Semiconductors reserves the right to change the specification in any manner without notice.
Preliminary data	Qualification	This data sheet contains data from the preliminary specification. Supplementary data will be published at a later date. Philips Semiconductors reserves the right to change the specification without notice, in order to improve the design and supply the best possible product.
Product data	Production	This data sheet contains data from the product specification. Philips Semiconductors reserves the right to make changes at any time in order to improve the design, manufacturing and supply. Changes will be communicated according to the Customer Product/Process Change Notification (CPCN) procedure SNW-SQ-650A.

Notes

1. Please consult the most recently issued data sheet before initiating or completing a design.
2. The product status of the device(s) described in this data sheet may have changed since this data sheet was published. The latest information is available on the Internet at URL <http://www.semiconductors.philips.com>.

DEFINITIONS

Short-form specification — The data in a short-form specification is extracted from a full data sheet with the same type number and title. For detailed information see the relevant data sheet or data handbook.

Limiting values definition — Limiting values given are in accordance with the Absolute Maximum Rating System (IEC 60134). Stress above one or more of the limiting values may cause permanent damage to the device. These are stress ratings only and operation of the device at these or at any other conditions above those given in the Characteristics sections of the specification is not implied. Exposure to limiting values for extended periods may affect device reliability.

Application information — Applications that are described herein for any of these products are for illustrative purposes only. Philips Semiconductors make no representation or warranty that such applications will be suitable for the specified use without further testing or modification.

DISCLAIMERS

Life support applications — These products are not designed for use in life support appliances, devices, or systems where malfunction of these products can reasonably be expected to result in personal injury. Philips Semiconductors customers using or selling these products for use in such applications do so at their own risk and agree to fully indemnify Philips Semiconductors for any damages resulting from such application.

Right to make changes — Philips Semiconductors reserves the right to make changes, without notice, in the products, including circuits, standard cells, and/or software, described or contained herein in order to improve design and/or performance. Philips Semiconductors assumes no responsibility or liability for the use of any of these products, conveys no licence or title under any patent, copyright, or mask work right to these products, and makes no representations or warranties that these products are free from patent, copyright, or mask work right infringement, unless otherwise specified.

Philips Semiconductors – a worldwide company

Contact information

For additional information please visit <http://www.semiconductors.philips.com>. Fax: +31 40 27 24825

For sales offices addresses send e-mail to: sales.addresses@www.semiconductors.philips.com.

© Koninklijke Philips Electronics N.V. 2001

SCA73

All rights are reserved. Reproduction in whole or in part is prohibited without the prior written consent of the copyright owner.

The information presented in this document does not form part of any quotation or contract, is believed to be accurate and reliable and may be changed without notice. No liability will be accepted by the publisher for any consequence of its use. Publication thereof does not convey nor imply any license under patent- or other industrial or intellectual property rights.

Printed in The Netherlands

753504/02/pp40

Date of release: 2001 Oct 19

Document order number: 9397 750 08403

Let's make things better.

**Philips
Semiconductors**



PHILIPS