

Features

- Two Different IF Receiving Bandwidth Versions Are Available ($B_{IF} = 300 \text{ kHz}$ or 600 kHz)
- 5 V to 20 V Automotive Compatible Data Interface
- IC Condition Indicator, Sleep or Active Mode
- Low Power Consumption Due to Configurable Self Polling with a Programmable Timeframe Check
- High Sensitivity, Especially at Low Data Rates
- Data Clock Available for Manchester- and Bi-phase-coded Signals
- Minimal External Circuitry Requirements, no RF Components on the PC Board Except Matching to the Receiver Antenna
- Sensitivity Reduction Possible Even While Receiving
- Fully Integrated VCO
- SO20 Package
- Supply Voltage 4.5 V to 5.5 V, Operating Temperature Range -40°C to $+105^{\circ}\text{C}$
- Single-ended RF Input for Easy Adaptation to $\lambda/4$ Antenna or Printed Antenna on PCB
- Low-cost Solution Due to High Integration Level
- ESD Protection According to MIL-STD. 883 (4KV HBM)
- High Image Frequency Suppression Due to 1 MHz IF in Conjunction with a SAW Front-end Filter. Up to 40 dB is Thereby Achievable With State-of-the-art SAWs.
- Communication to Microcontroller Possible Via a Single, Bi-directional Data Line
- Power Management (Polling) Is Also Possible by Means of a Separate Pin Via the Microcontroller
- Programmable Digital Noise Suppression

Description

The T5743 is a multi-chip PLL receiver device supplied in an SO20 package. It has been especially developed for the demands of RF low-cost data transmission systems with data rates from 1 kBaud to 10 kBaud in Manchester or Bi-phase code. The receiver is well suited to operate with Atmel's PLL RF transmitter U2741B. Its main applications are in the areas of telemetry, security technology and keyless-entry systems. It can be used in the frequency receiving range of $f_0 = 300 \text{ MHz}$ to 450 MHz for ASK or FSK data transmission. All the statements made below refer to 433.92 MHz and 315 MHz applications.

System Block Diagram

Figure 1. System Block Diagram

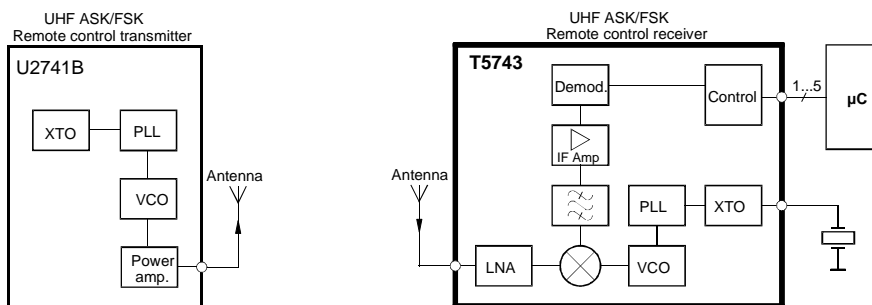

UHF ASK/FSK Receiver

T5743

Preliminary



Pin Configuration

Figure 2. Pinning SO20

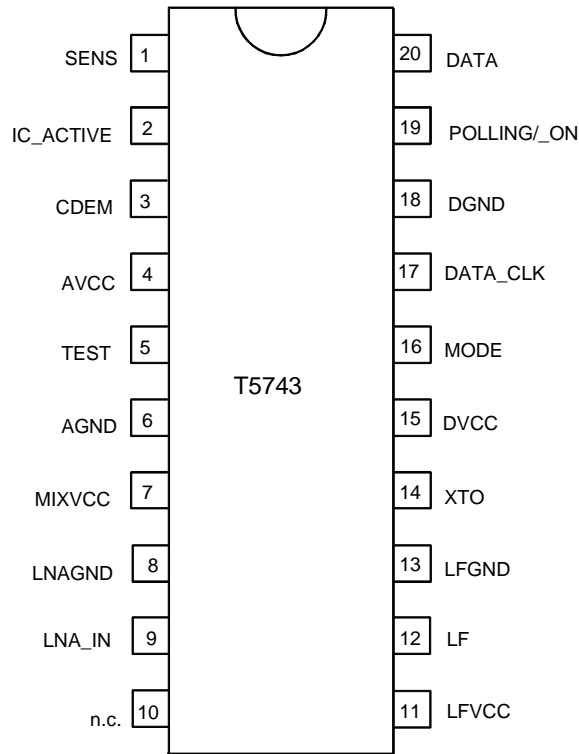

Pin Description

Pin	Symbol	Function
1	SENS	Sensitivity-control resistor
2	IC_ACTIVE	IC condition indicator Low = sleep mode High = active mode
3	CDEM	Lower cut-off frequency data filter
4	AVCC	Analog power supply
5	TEST	Test pin, during operation at GND
6	AGND	Analog ground
7	MIXVCC	Power supply mixer
8	LNAGND	High-frequency ground LNA and mixer
9	LNA_IN	RF input
10	n.c.	Not connected
11	LFVCC	Power supply VCO
12	LF	Loop filter
13	LFGND	Ground VCO
14	XTO	Crystal oscillator

Pin Description (Continued)

Pin	Symbol	Function
15	DVCC	Digital power supply
16	MODE	Selecting 433.92 MHz/315 MHz Low: $f_{XT0} = 4.90625$ MHz (USA) High: $f_{XT0} = 6.76438$ MHz (Europe)
17	DATA_CLK	Bit clock of data stream
18	DGND	Digital ground
19	POLLING/_ON	Selects polling or receiving mode Low: receiving mode High: polling mode
20	DATA	Data output/configuration input

Figure 3. Block Diagram

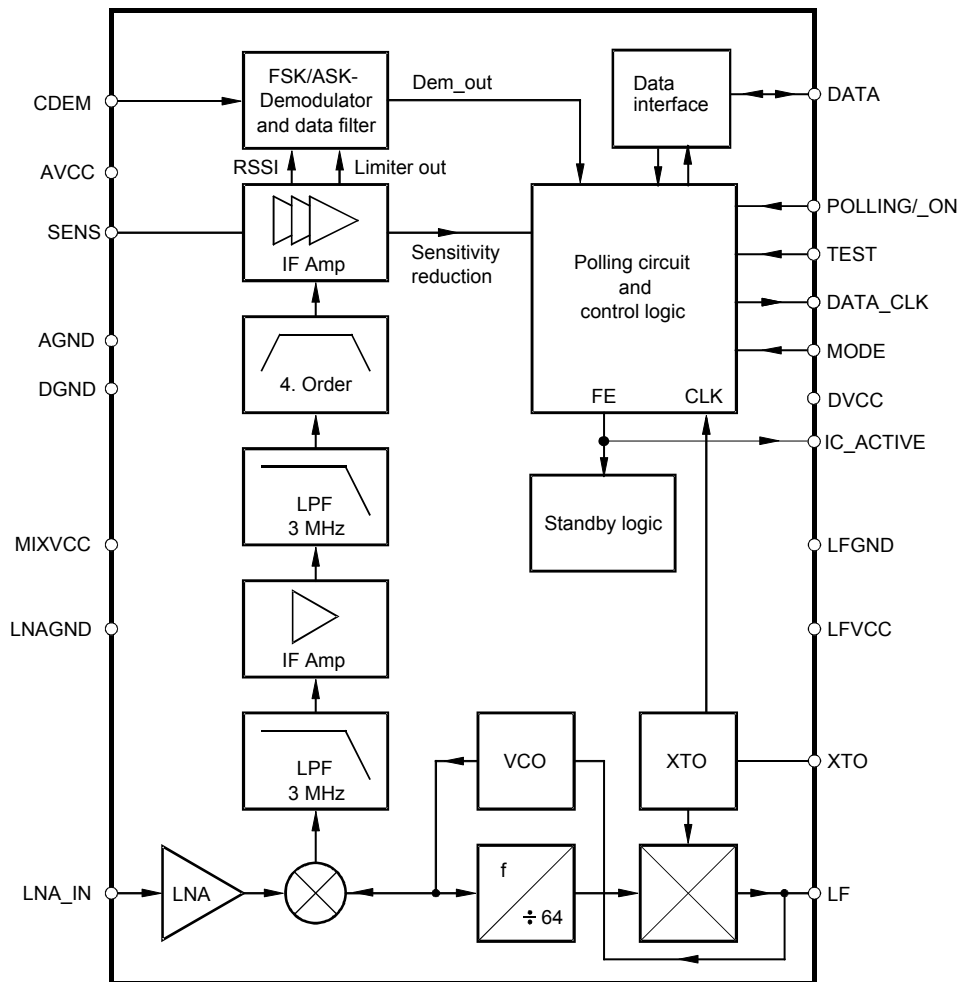

RF Front-end

The RF front-end of the receiver is a heterodyne configuration that converts the input signal into a 1 MHz IF signal. According to Figure 3, the front-end consists of an LNA (low-noise amplifier), LO (local oscillator), a mixer and an RF amplifier.

The LO generates the carrier frequency for the mixer via a PLL synthesizer. The XTO (crystal oscillator) generates the reference frequency f_{XTO} . The VCO (voltage-controlled oscillator) generates the drive voltage frequency f_{LO} for the mixer. f_{LO} is dependent on the voltage at Pin LF. f_{LO} is divided by factor 64. The divided frequency is compared to f_{XTO} by the phase frequency detector. The current output of the phase frequency detector is connected to a passive loop filter and thereby generates the control voltage V_{LF} for the VCO. By means of that configuration V_{LF} is controlled in a way that $f_{LO}/64$ is equal to f_{XTO} . If f_{LO} is determined, f_{XTO} can be calculated using the following formula: $f_{XTO} = f_{LO}/64$.

The XTO is a one-pin oscillator that operates at the series resonance of the quartz crystal. According to Figure 4, the crystal should be connected to GND via a capacitor C_L . The value of that capacitor is recommended by the crystal supplier. The value of C_L should be optimized for the individual board layout to achieve the exact value of f_{XTO} and hereby of f_{LO} . When designing the system in terms of receiving bandwidth, the accuracy of the crystal and the XTO must be considered.

Figure 4. PLL Peripherals

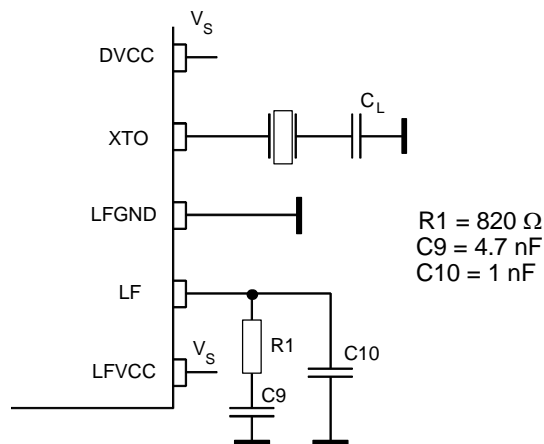

The passive loop filter connected to Pin LF is designed for a loop bandwidth of $B_{Loop} = 100 \text{ kHz}$. This value for B_{Loop} exhibits the best possible noise performance of the LO. Figure 4 shows the appropriate loop filter components to achieve the desired loop bandwidth. If the filter components are changed for any reason please notify that the maximum capacitive load at Pin LF is limited. If the capacitive load is exceeded, a bit check may no longer be possible since f_{LO} cannot settle in time before the bit check starts to evaluate the incoming data stream. Self polling does therefore also not work in that case.

f_{LO} is determined by the RF input frequency f_{RF} and the IF frequency f_{IF} using the following formula: $f_{LO} = f_{RF} - f_{IF}$

To determine f_{LO} , the construction of the IF filter must be considered at this point. The nominal IF frequency is $f_{IF} = 1 \text{ MHz}$. To achieve a good accuracy of the filter's corner frequencies, the filter is tuned by the crystal frequency f_{XTO} . This means that there is a fixed relation between f_{IF} and f_{LO} . This relation is dependent on the logic level at Pin MODE.

This is described by the following formulas:

$$\text{MODE} = 0 \text{ (USA)} : f_{\text{IF}} = \frac{f_{\text{LO}}}{314}$$

$$\text{MODE} = 1 \text{ (Europe)} : f_{\text{IF}} = \frac{f_{\text{LO}}}{432.92}$$

The relation is designed to achieve the nominal IF frequency of $f_{\text{IF}} = 1 \text{ MHz}$ for most applications. For applications where $f_{\text{RF}} = 315 \text{ MHz}$, MODE must be set to '0'. In the case of $f_{\text{RF}} = 433.92 \text{ MHz}$, MODE must be set to '1'. For other RF frequencies, f_{IF} is not equal to 1 MHz. f_{IF} is then dependent on the logical level at Pin MODE and on f_{RF} . Table 1 summarizes the different conditions.

The RF input either from an antenna or from a generator must be transformed to the RF input Pin LNA_IN. The input impedance of that pin is provided in the electrical parameters. The parasitic board inductances and capacitances also influence the input matching. The RF receiver T5743 exhibits its highest sensitivity at the best signal-to-noise ratio in the LNA. Hence, noise matching is the best choice for designing the transformation network.

A good practice when designing the network is to start with power matching. From that starting point, the values of the components can be varied to some extent to achieve the best sensitivity.

If a SAW is implemented into the input network a mirror frequency suppression of $\Delta P_{\text{Ref}} = 40 \text{ dB}$ can be achieved. There are SAWs available that exhibit a notch at $\Delta f = 2 \text{ MHz}$. These SAWs work best for an intermediate frequency of $f_{\text{IF}} = 1 \text{ MHz}$. The selectivity of the receiver is also improved by using a SAW. In typical automotive applications, a SAW is used.

Figure 5 shows a typical input matching network, for $f_{\text{RF}} = 315 \text{ MHz}$ and $f_{\text{RF}} = 433.92 \text{ MHz}$ using a SAW. Figure 6 illustrates an according input matching to 50 Ω without a SAW. The input matching networks shown in Figure 6 are the reference networks for the parameters given in the electrical characteristics.

Table 1. Calculation of LO and IF Frequency

Conditions	Local Oscillator Frequency	Intermediate Frequency
$f_{\text{RF}} = 315 \text{ MHz}$, MODE = 0	$f_{\text{LO}} = 314 \text{ MHz}$	$f_{\text{IF}} = 1 \text{ MHz}$
$f_{\text{RF}} = 433.92 \text{ MHz}$, MODE = 1	$f_{\text{LO}} = 432.92 \text{ MHz}$	$f_{\text{IF}} = 1 \text{ MHz}$
$300 \text{ MHz} < f_{\text{RF}} < 365 \text{ MHz}$, MODE = 0	$f_{\text{LO}} = \frac{f_{\text{RF}}}{1 + \frac{1}{314}}$	$f_{\text{IF}} = \frac{f_{\text{LO}}}{314}$
$365 \text{ MHz} < f_{\text{RF}} < 450 \text{ MHz}$, MODE = 1	$f_{\text{LO}} = \frac{f_{\text{RF}}}{1 + \frac{1}{432.92}}$	$f_{\text{IF}} = \frac{f_{\text{LO}}}{432.92}$

Figure 5. Input Matching Network with SAW Filter

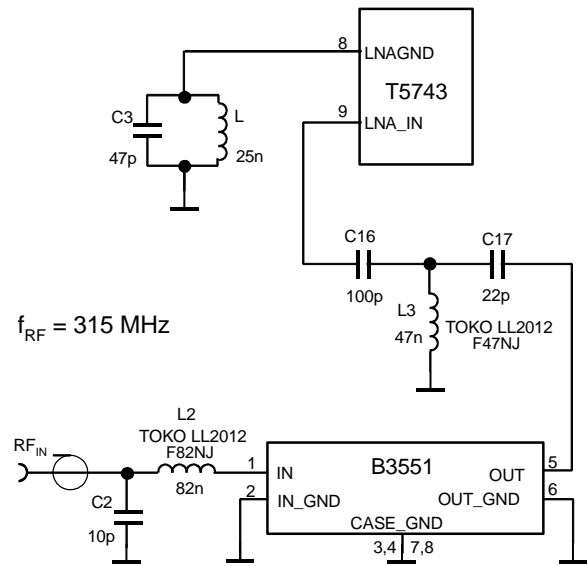
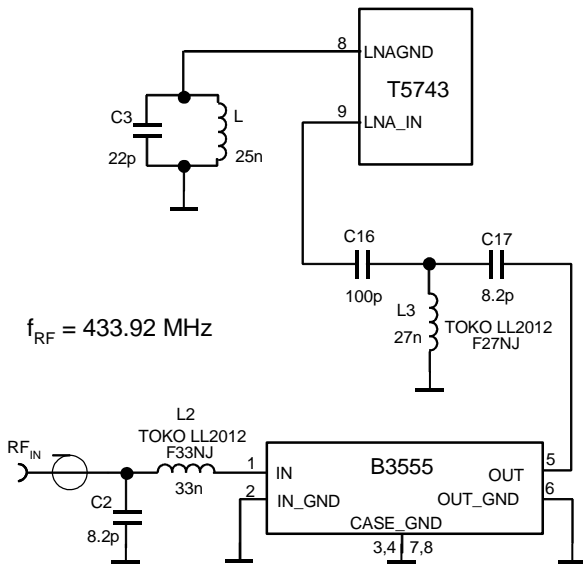
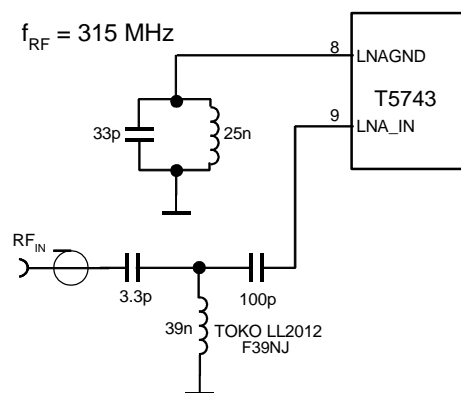
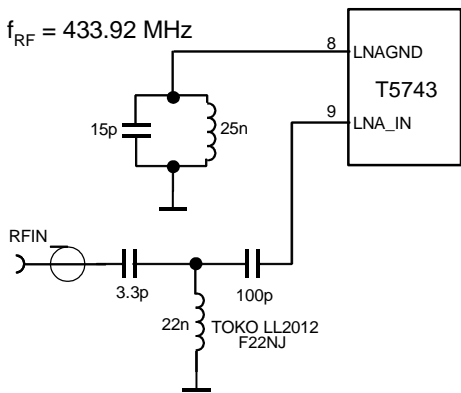

Figure 6. Input Matching Network without SAW Filter



Please notify that for all coupling conditions (see Figure 5 and Figure 6), the bond wire inductivity of the LNA ground is compensated. C3 forms a series resonance circuit together with the bond wire. L = 25 nH is a feed inductor to establish a DC path. Its value is not critical but must be large enough not to detune the series resonance circuit. For cost reduction this inductor can be easily printed on the PCB. This configuration improves the sensitivity of the receiver by about 1 dB to 2 dB.

Analog Signal Processing

IF Amplifier

The signals coming from the RF front-end are filtered by the fully integrated 4th-order IF filter. The IF center frequency is $f_{IF} = 1$ MHz for applications where $f_{RF} = 315$ MHz or $f_{RF} = 433.92$ MHz is used. For other RF input frequencies refer to Table 1 to determine the center frequency.

The T5743 is available with two different IF bandwidths. T5743P3, the version with $B_{IF} = 300$ kHz, is well suited for ASK systems where Atmel's PLL transmitter U2741B is used. The receiver T5743P6 employs an IF bandwidth of $B_{IF} = 600$ kHz. Both versions can be used together with the U2741B in ASK and FSK mode. If used in ASK applications, it allows higher tolerances for the receiver and PLL transmitter crystals. SAW transmitters exhibit much higher transmit frequency tolerances compared to PLL transmitters. Generally, it is necessary to use $B_{IF} = 600$ kHz together with such transmitters.

RSSI Amplifier

The subsequent RSSI amplifier enhances the output signal of the IF amplifier before it is fed into the demodulator. The dynamic range of this amplifier is $DR_{RSSI} = 60$ dB. If the RSSI amplifier is operated within its linear range, the best S/N ratio is maintained in ASK mode. If the dynamic range is exceeded by the transmitter signal, the S/N ratio is defined by the ratio of the maximum RSSI output voltage and the RSSI output voltage due to a disturber. The dynamic range of the RSSI amplifier is exceeded if the RF input signal is about 60 dB higher compared to the RF input signal at full sensitivity.

In FSK mode the S/N ratio is not affected by the dynamic range of the RSSI amplifier.

The output voltage of the RSSI amplifier is internally compared to a threshold voltage V_{Th_red} . V_{Th_red} is determined by the value of the external resistor R_{Sens} . R_{Sens} is connected between Pin SENS and GND or V_S . The output of the comparator is fed into the digital control logic. By this means it is possible to operate the receiver at a lower sensitivity.

If R_{Sens} is connected to GND, the receiver operates at full sensitivity.

If R_{Sens} is connected to V_S , the receiver operates at a lower sensitivity. The reduced sensitivity is defined by the value of R_{Sens} , the maximum sensitivity by the signal-to-noise ratio of the LNA input. The reduced sensitivity depends on the signal strength at the output of the RSSI amplifier.

Since different RF input networks may exhibit slightly different values for the LNA gain, the sensitivity values given in the electrical characteristics refer to a specific input matching. This matching is illustrated in Figure 6 and exhibits the best possible sensitivity.

R_{Sens} can be connected to V_S or GND via a microcontroller. The receiver can be switched from full sensitivity to reduced sensitivity or vice versa at any time. In polling mode, the receiver will not wake up if the RF input signal does not exceed the selected sensitivity. If the receiver is already active, the data stream at Pin DATA will disappear when the input signal is lower than defined by the reduced sensitivity. Instead of the data stream, the pattern according to Figure 7 is issued at Pin DATA to indicate that the receiver is still active (see also figure 34).

Figure 7. Steady L State Limited DATA Output Pattern



FSK/ASK Demodulator and Data Filter

The signal coming from the RSSI amplifier is converted into the raw data signal by the ASK/FSK demodulator. The operating mode of the demodulator is set via the bit ASK/_FSK in the OPMODE register. Logic 'L' sets the demodulator to FSK, applying 'H' to ASK mode.

In ASK mode, an automatic threshold control circuit (ATC) is used to set the detection reference voltage to a value where a good signal-to-noise ratio is achieved. This circuit effectively suppresses any kind of inband noise signals or competing transmitters. If the S/N (ratio to suppress inband noise signals) exceeds 10 dB, the data signal can be detected properly.

The FSK demodulator is intended to be used for an FSK deviation of $10 \text{ kHz} \leq \Delta f \leq 100 \text{ kHz}$. In FSK mode the data signal can be detected if the S/N (ratio to suppress inband noise signals) exceeds 2 dB. This value is guaranteed for all modulation schemes of a disturber signal.

The output signal of the demodulator is filtered by the data filter before it is fed into the digital signal processing circuit. The data filter improves the S/N ratio as its passband can be adopted to the characteristics of the data signal. The data filter consists of a 1st-order highpass and a 2nd-order lowpass filter.

The highpass filter cut-off frequency is defined by an external capacitor connected to Pin CDEM. The cut-off frequency of the highpass filter is defined by the following formula:

$$f_{cu_DF} = \frac{1}{2 \times \pi \times 30 \text{ k}\Omega \times \text{CDEM}}$$

In self-polling mode, the data filter must settle very rapidly to achieve a low current consumption. Therefore, CDEM cannot be increased to very high values if self-polling is used. On the other hand, CDEM must be large enough to meet the data filter requirements according to the data signal. Recommended values for CDEM are given in the electrical characteristics.

The cut-off frequency of the lowpass filter is defined by the selected baud-rate range (BR_Range). The BR_Range is defined in the OPMODE register (refer to section 'Configuration of the Receiver'). The BR_Range must be set in accordance to the used baud rate.

The T5743 is designed to operate with data coding where the DC level of the data signal is 50%. This is valid for Manchester and Bi-phase coding. If other modulation schemes are used, the DC level should always remain within the range of $V_{DC_min} = 33\%$ and $V_{DC_max} = 66\%$. The sensitivity may be reduced by up to 2 dB in that condition.

Each BR_Range is also defined by a minimum and a maximum edge-to-edge time (t_{ee_sig}). These limits are defined in the electrical characteristics. They should not be exceeded to maintain full sensitivity of the receiver.

Receiving Characteristics

The RF receiver T5743 can be operated with and without a SAW front-end filter. In a typical automotive application, a SAW filter is used to achieve better selectivity. The selectivity with and without a SAW front-end filter is illustrated in Figure 8. This example relates to ASK mode and the 300-kHz bandwidth version of the T5743. FSK mode and the 600-kHz bandwidth version of the receiver exhibits similar behavior. Note that the mirror frequency is reduced by 40 dB. The plots are printed relatively to the maximum sensitivity. If a SAW filter is used, an insertion loss of about 4 dB must be considered.

Figure 8. Receiving Frequency Response

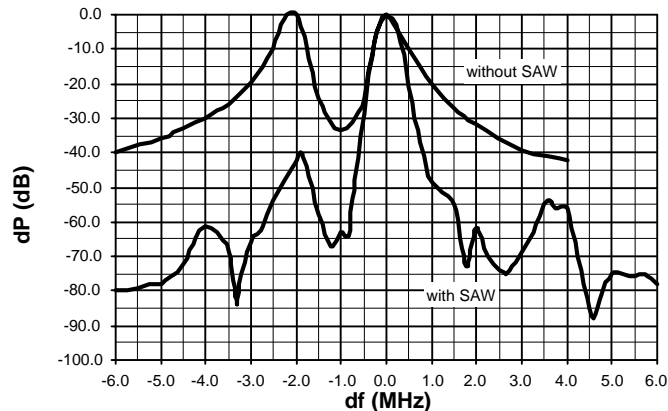

When designing the system in terms of receiving bandwidth, the LO deviation must be considered as it also determines the IF center frequency. The total LO deviation is calculated to be the sum of the deviation of the crystal and the XTO deviation of the T5743. Low-cost crystals are specified to be within ± 100 ppm. The XTO deviation of the T5743 is an additional deviation due to the XTO circuit. This deviation is specified to be ± 30 ppm. If a crystal of ± 100 ppm is used, the total deviation is ± 130 ppm in that case. Note that the receiving bandwidth and the IF-filter bandwidth are equivalent in ASK mode but not in FSK mode.

Polling Circuit and Control Logic

The receiver is designed to consume less than 1 mA while being sensitive to signals from a corresponding transmitter. This is achieved via the polling circuit. This circuit enables the signal path periodically for a short time. During this time the bit-check logic verifies the presence of a valid transmitter signal. Only if a valid signal is detected the receiver remains active and transfers the data to the connected microcontroller. If there is no valid signal present the receiver is in sleep mode most of the time resulting in low current consumption. This condition is called polling mode. A connected microcontroller is disabled during that time.

All relevant parameters of the polling logic can be configured by the connected microcontroller. This flexibility enables the user to meet the specifications in terms of current consumption, system response time, data rate etc.

Regarding the number of connection wires to the microcontroller, the receiver is very flexible. It can be either operated by a single bi-directional line to save ports to the connected microcontroller or it can be operated by up to five uni-directional ports.

Basic Clock Cycle of the Digital Circuitry

The complete timing of the digital circuitry and the analog filtering is derived from one clock. According to Figure 9, this clock cycle T_{Clk} is derived from the crystal oscillator (XTO) in combination with a divider. The division factor is controlled by the logical state at Pin MODE. According to section "RF Front-end", the frequency of the crystal oscillator (f_{XTO}) is defined by the RF input signal (f_{RFIn}) which also defines the operating frequency of the local oscillator (f_{LO}).

Figure 9. Generation of the Basic Clock Cycle

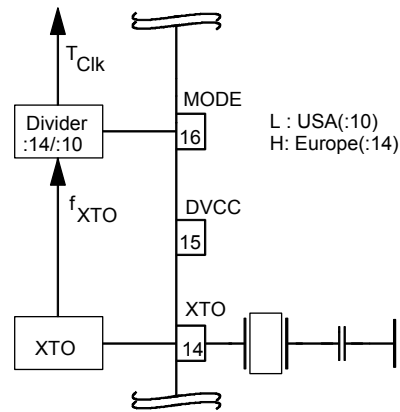

Pin MODE can now be set in accordance with the desired clock cycle T_{Clk} . T_{Clk} controls the following application relevant parameters:

- Timing of the polling circuit including bit check
- Timing of the analog and digital signal processing
- Timing of the register programming
- Frequency of the reset marker
- IF filter center frequency (f_{IF0})

Most applications are dominated by two transmission frequencies: $f_{Send} = 315$ MHz is mainly used in USA, $f_{Send} = 433.92$ MHz in Europe. In order to ease the usage of all T_{Clk} -dependent parameters on this electrical characteristics display three conditions for each parameter.

- Application USA ($f_{XTO} = 4.90625$ MHz, MODE = L, $T_{Clk} = 2.0383$ μ s)
- Application Europe ($f_{XTO} = 6.76438$ MHz, MODE = H, $T_{Clk} = 2.0697$ μ s)
- Other applications (T_{Clk} is dependent on f_{XTO} and on the logical state of Pin MODE. The electrical characteristic is given as a function of T_{Clk}).

The clock cycle of some function blocks depends on the selected baud-rate range (BR_Range) which is defined in the OPMODE register. This clock cycle T_{XClk} is defined by the following formulas for further reference:

$$\begin{aligned}
 \text{BR_Range} = \text{BR_Range0: } & T_{XClk} = 8 \times T_{Clk} \\
 \text{BR_Range1: } & T_{XClk} = 4 \times T_{Clk} \\
 \text{BR_Range2: } & T_{XClk} = 2 \times T_{Clk} \\
 \text{BR_Range3: } & T_{XClk} = 1 \times T_{Clk}
 \end{aligned}$$

Polling Mode

According to Figure 10, the receiver stays in polling mode in a continuous cycle of three different modes. In sleep mode the signal processing circuitry is disabled for the time period T_{Sleep} while consuming low current of $I_S = I_{Soff}$. During the start-up period, $T_{Startup}$, all signal processing circuits are enabled and settled. In the following bit-check mode, the incoming data stream is analyzed bit by bit contra a valid transmitter signal. If no valid signal is present, the receiver is set back to sleep mode after the period $T_{Bit-check}$. This period varies check by check as it is a statistical process. An average value for $T_{Bit-check}$ is given in the electrical characteristics. During $T_{Startup}$ and $T_{Bit-check}$ the current consumption is $I_S = I_{Son}$. The condition of the receiver is indicated on Pin IC_ACTIVE. The average current consumption in polling mode is dependent on the duty cycle of the active mode and can be calculated as:

$$I_{\text{Spoll}} = \frac{I_{\text{Soff}} \times T_{\text{Sleep}} + I_{\text{Son}} \times (T_{\text{Startup}} + T_{\text{Bit-check}})}{T_{\text{Sleep}} + T_{\text{Startup}} + T_{\text{Bit-check}}}$$

During T_{Sleep} and T_{Startup} the receiver is not sensitive to a transmitter signal. To guarantee the reception of a transmitted command the transmitter must start the telegram with an adequate preburst. The required length of the preburst depends on the polling parameters T_{Sleep} , T_{Startup} , $T_{\text{Bit-check}}$ and the start-up time of a connected microcontroller ($T_{\text{Start},\mu\text{C}}$). Thus, $T_{\text{Bit-check}}$ depends on the actual bit rate and the number of bits ($N_{\text{Bit-check}}$) to be tested.

The following formula indicates how to calculate the preburst length.

$$T_{\text{Purburst}} \geq T_{\text{Sleep}} + T_{\text{Startup}} + T_{\text{Bit-check}} + T_{\text{Start},\mu\text{C}}$$

Sleep Mode

The length of period T_{Sleep} is defined by the 5-bit word Sleep of the OPMODE register, the extension factor XSleep (according to Table 9), and the basic clock cycle T_{Clk} . It is calculated to be:

$$T_{\text{Sleep}} = \text{Sleep} \times X_{\text{Sleep}} \times 1024 \times T_{\text{Clk}}$$

In US- and European applications, the maximum value of T_{Sleep} is about 60 ms if XSleep is set to 1. The time resolution is about 2 ms in that case. The sleep time can be extended to almost half a second by setting XSleep to 8. XSleep can be set to 8 by bit XSleep_{Std} to 1.

According to Table 8, the highest register value of sleep sets the receiver into a permanent sleep condition. The receiver remains in that condition until another value for Sleep is programmed into the OPMODE register. This function is desirable where several devices share a single data line and may also be used for microcontroller polling — via Pin POLLING/_ON, the receiver can be switched on and off.

Figure 10. Polling Mode Flow Chart

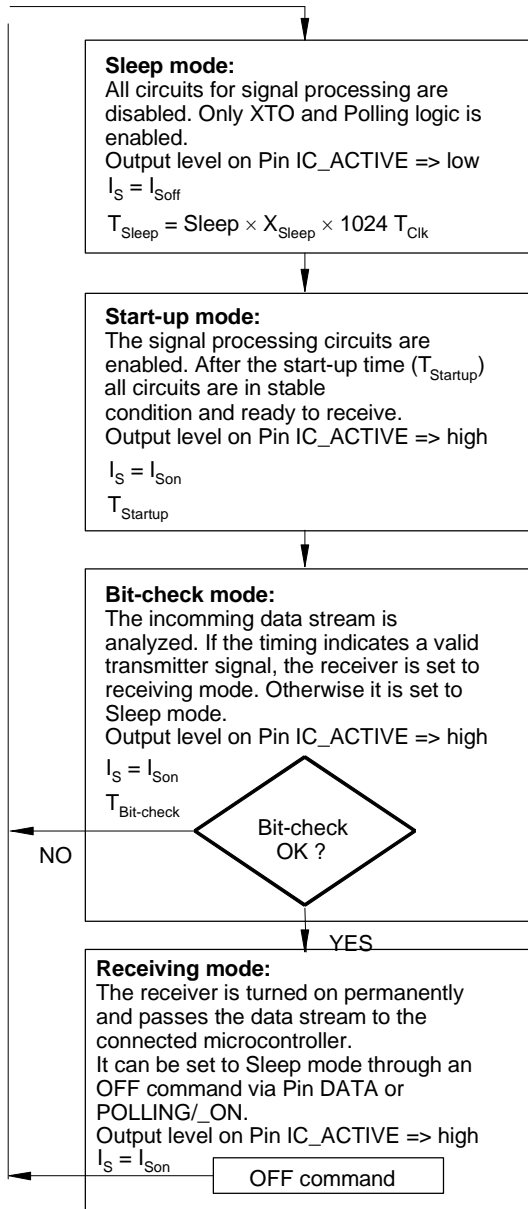

Sleep: 5-bit word defined by Sleep0 to Sleep4 in OPMODE register

XSleep: Extension factor defined by XSleep_{Std} according to Table 9

T_{Clk}: Basic clock cycle defined by f_{XTO} and Pin MODE

T_{Startup}: Is defined by the selected baud rate range and T_{Clk}. The baud-rate range is defined by Baud0 and Baud1 in the OPMODE register.

T_{Bit-check}: Depends on the result of the bit check.

If the bit check is ok, T_{Bit-check} depends on the number of bits to be checked (N_{Bit-check}) and on the utilized data rate.

If the bit check fails, the average time period for that check depends on the selected baud-rate range and on T_{Clk}. The baud-rate range is defined by Baud0 and Baud1 in the OPMODE register

Figure 11. Timing Diagram for Complete Successful Bit Check

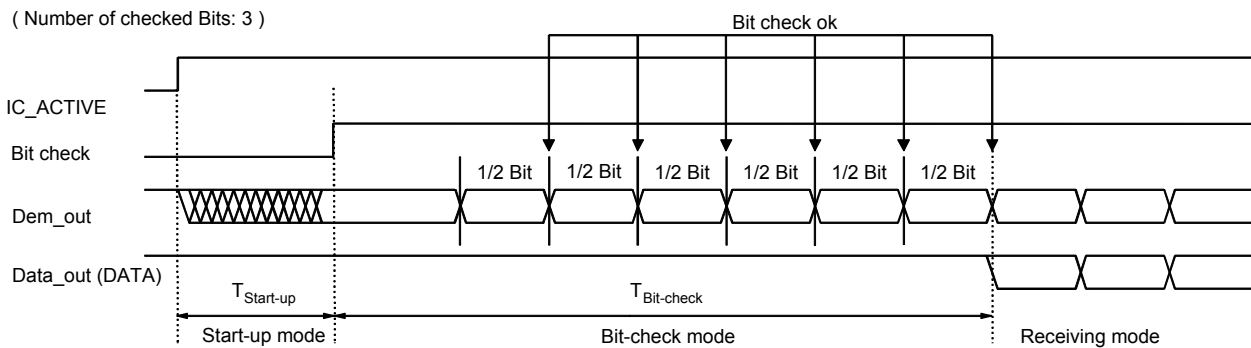

Bit-check Mode

In bit-check mode the incoming data stream is examined to distinguish between a valid signal from a corresponding transmitter and signals due to noise. This is done by subsequent time frame checks where the distances between two signal edges are continuously compared to a programmable time window. The maximum count of this edge-to-edge tests before the receiver switches to receiving mode is also programmable.

Configuring the Bit Check

Assuming a modulation scheme that contains two edges per bit, two time frame checks are verifying one bit. This is valid for Manchester, Bi-phase and most other modulation schemes. The maximum count of bits to be checked can be set to 0, 3, 6 or 9 bits via the variable $N_{\text{Bit-check}}$ in the OPMODE register. This implies 0, 6, 12 and 18 edge to edge checks respectively. If $N_{\text{Bit-check}}$ is set to a higher value, the receiver is less likely to switch to receiving mode due to noise. In the presence of a valid transmitter signal, the bit check takes less time if $N_{\text{Bit-check}}$ is set to a lower value. In polling mode, the bit-check time is not dependent on $N_{\text{Bit-check}}$. Figure 11 shows an example where 3 bits are tested successfully and the data signal is transferred to Pin DATA.

According to Figure 12, the time window for the bit check is defined by two separate time limits. If the edge-to-edge time t_{ee} is in between the lower bit-check limit $T_{\text{Lim_min}}$ and the upper bit-check limit $T_{\text{Lim_max}}$, the check will be continued. If t_{ee} is smaller than $T_{\text{Lim_min}}$ or t_{ee} exceeds $T_{\text{Lim_max}}$, the bit check will be terminated and the receiver switches to sleep mode.

Figure 12. Valid Time Window for Bit Check

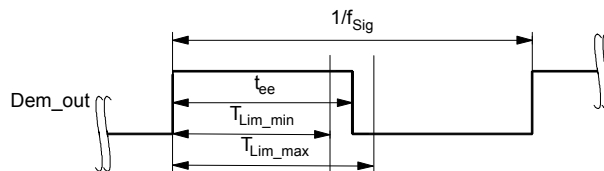

For best noise immunity it is recommended to use a low span between $T_{\text{Lim_min}}$ and $T_{\text{Lim_max}}$. This is achieved using a fixed frequency at a 50% duty cycle for the transmitter preburst. A “11111...” or a “10101...” sequence in Manchester or Bi-phase is a good choice concerning that advice. A good compromise between receiver sensitivity and susceptibility to noise is a time window of $\pm 25\%$ regarding the expected edge-to-edge time t_{ee} . Using pre-burst patterns that contain various edge-to-edge time periods, the bit-check limits must be programmed according to the required span.

The bit-check limits are determined by means of the formula below.

$$T_{Lim_min} = Lim_min \times T_{XCik}$$

$$T_{Lim_max} = (Lim_max - 1) \times T_{XCik}$$

Lim_min and Lim_max are defined by a 5-bit word each within the LIMIT register.

Using above formulas, Lim_min and Lim_max can be determined according to the required T_{Lim_min} , T_{Lim_max} and T_{XCik} . The time resolution defining T_{Lim_min} and T_{Lim_max} is T_{XCik} . The minimum edge-to-edge time t_{ee} ($t_{DATA_L_min}$, $t_{DATA_H_min}$) is defined according to the section 'Receiving Mode'. The lower limit should be set to $Lim_min \geq 10$. The maximum value of the upper limit is $Lim_max = 63$.

If the calculated value for Lim_min is < 19 , it is recommended to check 6 or 9 bits ($N_{Bit-check}$) to prevent switching to receiving mode due to noise.

Figure 13, Figure 14 and Figure 15 illustrate the bit check for the bit-check limits $Lim_min = 14$ and $Lim_max = 24$. When the IC is enabled, the signal processing circuits are enabled during $T_{Startup}$. The output of the ASK/FSK demodulator (Dem_out) is undefined during that period. When the bit check becomes active, the bit-check counter is clocked with the cycle T_{XCik} .

Figure 13 shows how the bit check proceeds if the bit-check counter value CV_Lim is within the limits defined by Lim_min and Lim_max at the occurrence of a signal edge. In Figure 14 the bit check fails as the value CV_lim is lower than the limit Lim_min. The bit check also fails if CV_Lim reaches Lim_max. This is illustrated in Figure 15.

Figure 13. Timing Diagram During Bit Check

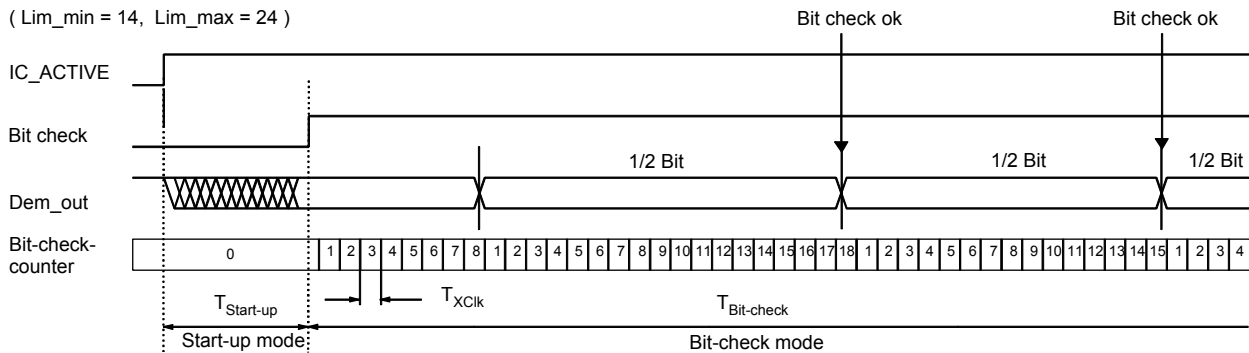

Figure 14. Timing Diagram for Failed Bit Check (Condition: CV_Lim < Lim_min)

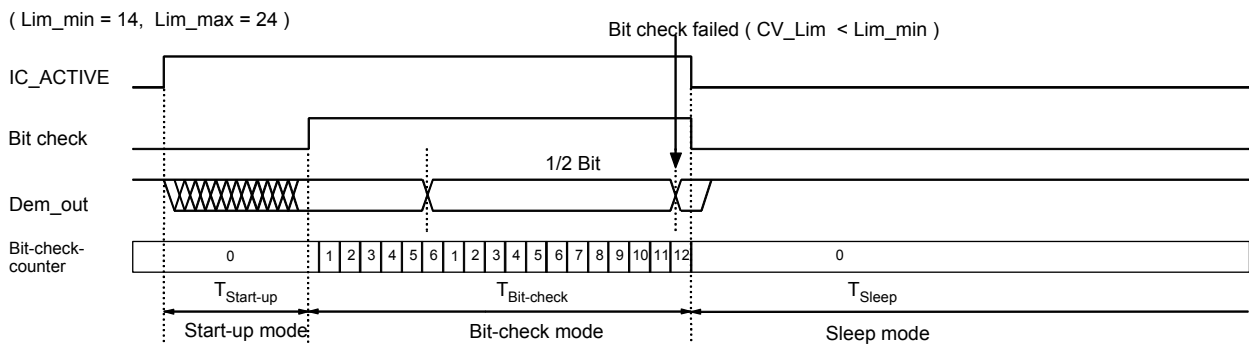
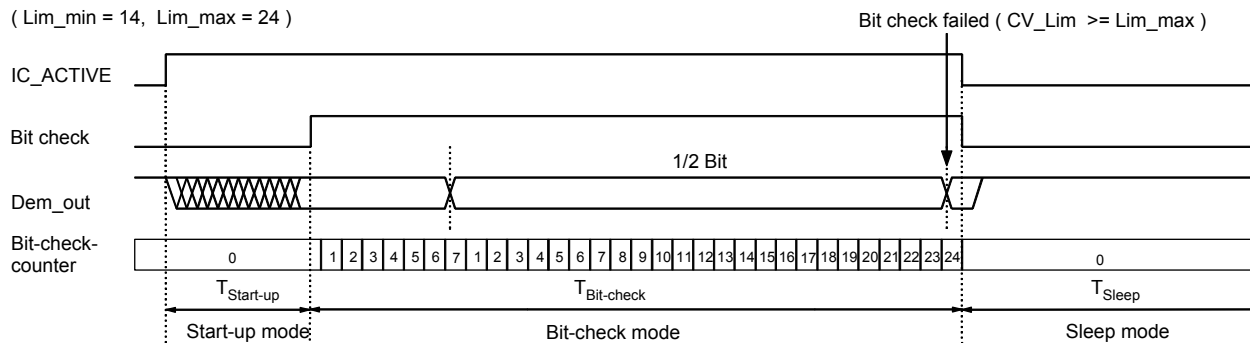

Figure 15. Timing Diagram for Failed Bit Check (Condition: $CV_Lim \geq Lim_max$)



Duration of the Bit Check

If no transmitter signal is present during the bit check, the output of the ASK/FSK demodulator delivers random signals. The bit check is a statistical process and $T_{Bit-check}$ varies for each check. Therefore, an average value for $T_{Bit-check}$ is given in the electrical characteristics. $T_{Bit-check}$ depends on the selected baud-rate range and on T_{Clk} . A higher baud-rate range causes a lower value for $T_{Bit-check}$ resulting in a lower current consumption in polling mode.

In the presence of a valid transmitter signal, $T_{Bit-check}$ is dependent on the frequency of that signal, f_{Sig} , and the count of the checked bits, $N_{Bit-check}$. A higher value for $N_{Bit-check}$ thereby results in a longer period for $T_{Bit-check}$ requiring a higher value for the transmitter pre-burst $T_{Preburst}$.

Receiving Mode

If the bit check was successful for all bits specified by $N_{Bit-check}$, the receiver switches to receiving mode. According to Figure 11, the internal data signal is switched to Pin DATA in that case and the data clock is available after the start bit has been detected (Figure 22). A connected microcontroller can be woken up by the negative edge at Pin DATA or by the data clock at Pin DATA_CLK. The receiver stays in that condition until it is switched back to polling mode explicitly.

Digital Signal Processing

The data from the ASK/FSK demodulator (Dem_out) is digitally processed in different ways and as a result converted into the output signal data. This processing depends on the selected baud-rate range (BR_Range). Figure 16 illustrates how Dem_out is synchronized by the extended clock cycle T_{XClk} . This clock is also used for the bit-check counter. Data can change its state only after T_{XClk} has elapsed. The edge-to-edge time period t_{ee} of the Data signal as a result is always an integral multiple of T_{XClk} .

The minimum time period between two edges of the data signal is limited to $t_{ee} \geq T_{DATA_min}$. This implies an efficient suppression of spikes at the DATA output. At the same time it limits the maximum frequency of edges at DATA. This eases the interrupt handling of a connected microcontroller.

The maximum time period for DATA to stay Low is limited to $T_{DATA_L_max}$. This function is employed to ensure a finite response time in programming or switching off the receiver via Pin DATA. $T_{DATA_L_max}$ is thereby longer than the maximum time period indicated by the transmitter data stream. Figure 18 gives an example where Dem_out remains Low after the receiver has switched to receiving mode.

Figure 16. Synchronization of the Demodulator Output

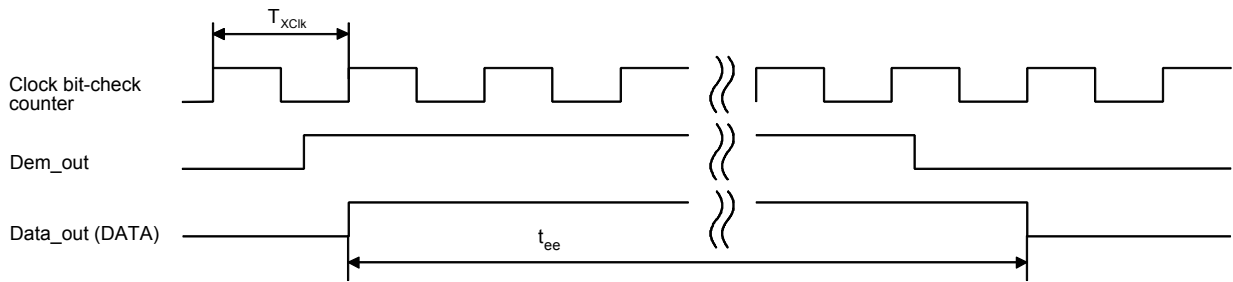

Figure 17. Debouncing of the Demodulator Output

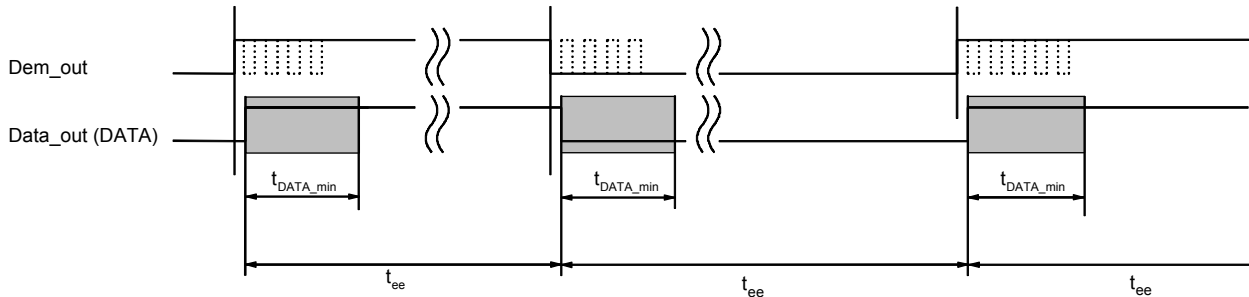
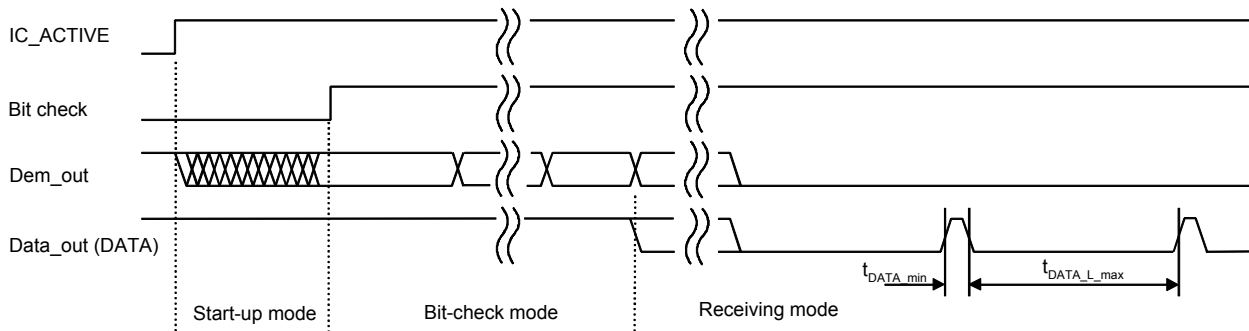

Figure 18. Steady L State Limited DATA Output Pattern After Transmission



After the end of a data transmission, the receiver remains active. Depending on the bit Noise_Disable in the OPMODE register, the output signal at Pin DATA is high or random noise pulses appear at Pin DATA (see section “Digital Noise Supression”). The edge-to-edge time period t_{ee} of the majority of these noise pulses is equal or slightly higher than T_{DATA_min} .

Switching the Receiver Back to Sleep Mode

The receiver can be set back to polling mode via Pin DATA or via Pin POLLING/_ON.

When using Pin DATA, this pin must be pulled to Low for the period t_1 by the connected microcontroller. Figure 19 illustrates the timing of the OFF command (see also Figure 34). The minimum value of t_1 depends on BR_Range. The maximum value for t_1 is not limited but it is recommended not to exceed the specified value to prevent erasing the reset marker. Note also that an internal reset for the OPMODE and the LIMIT register will be generated if t_1 exceeds the specified values. This item is explained in more detail in the section "Configuration of the Receiver". Setting the receiver to sleep mode via DATA is achieved by programming bit 1 to be "1" during the register configuration. Only one sync pulse (t_3) is issued.

The duration of the OFF command is determined by the sum of t_1 , t_2 and t_{10} . After the OFF command the sleep time T_{Sleep} elapses. Note that the capacitive load at Pin DATA is limited (see section "Data Interface").

Figure 19. Timing Diagram of the OFF-command via Pin DATA

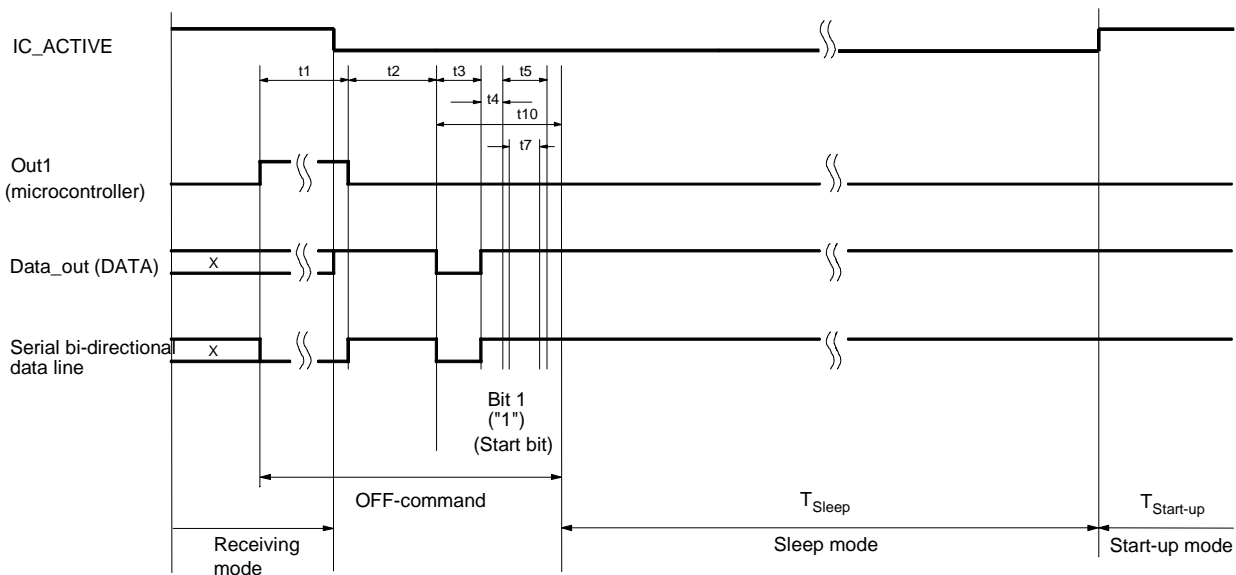

Figure 20. Timing Diagram of the OFF-command via Pin POLLING/_ON

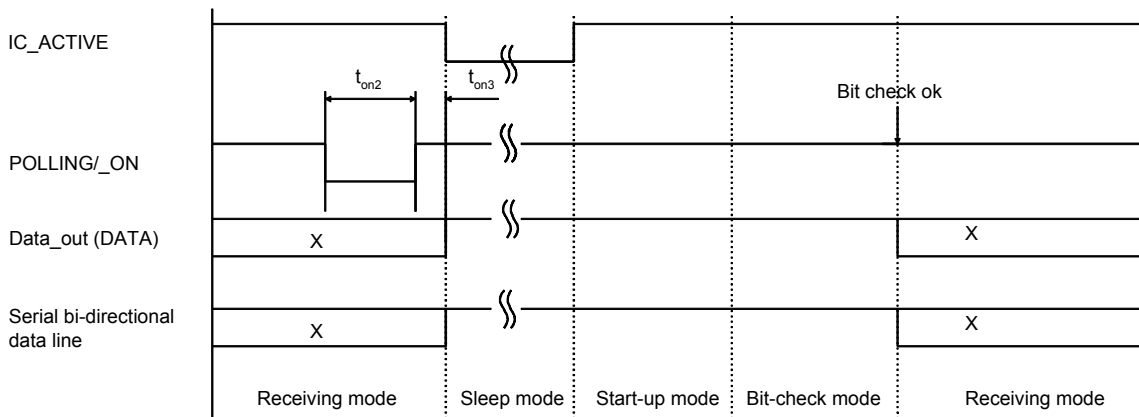

Figure 21. Activating the Receiving Mode via Pin POLLING/_ON

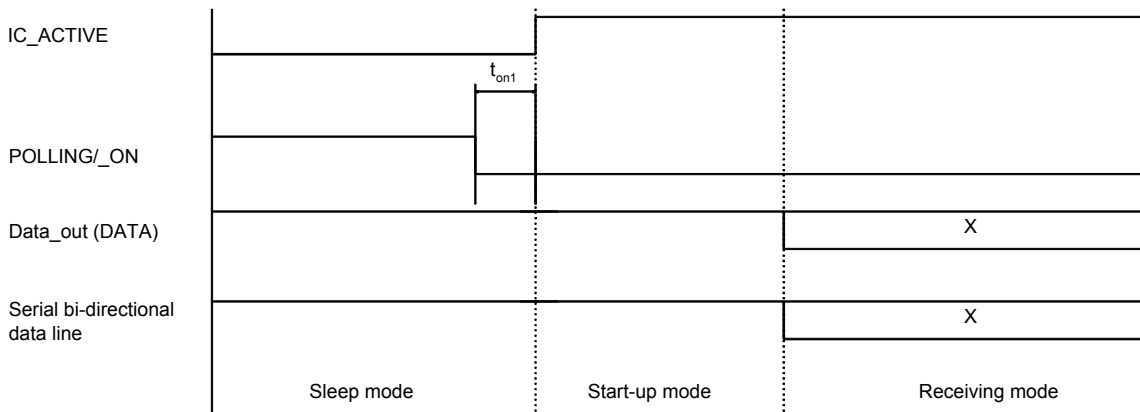

Figure 20 illustrates how to set the receiver back to polling mode via Pin POLLING/_ON. The Pin POLLING/_ON must be held to low for the time period t_{on2} . After the positive edge on Pin POLLING/_ON and the delay t_{on3} , the polling mode is active and the sleep time T_{Sleep} elapses.

This command is faster than using Pin DATA at the cost of an additional connection to the microcontroller.

Figure 21 illustrates how to set the receiver to receiving mode via the Pin POLLING/_ON. The Pin POLLING/_ON must be held to Low. After the delay t_{on1} , the receiver changes from sleep mode to start-up mode regardless the programmed values for T_{Sleep} and $N_{Bit-check}$. As long as POLLING/_ON is held to Low, the values for T_{Sleep} and $N_{Bit-check}$ will be ignored, but not deleted (see also section “Digital Noise Suppression”).

If the receiver is polled exclusively by a microcontroller, T_{Sleep} must be programmed to 31 (permanent sleep mode). In this case the receiver remains in sleep mode as long as POLLING/_ON is held to High.

Data Clock

The Pin DATA_CLK makes a data shift clock available to sample the data stream into a shift register. Using this data clock, a microcontroller can easily synchronize the data stream. This clock can only be used for Manchester and Bi-phase coded signals.

Generation of the data clock:

After a successful bit check, the receiver switches from polling mode to receiving mode and the data stream is available at Pin DATA. In receiving mode, the data clock control logic (Manchester/Bi-phase demodulator) is active and examines the incoming data stream. This is done, like in the bit check, by subsequent time frame checks where the distance between two edges is continuously compared to a programmable time window. As illustrated in Figure 22, only two distances between two edges in Manchester and Bi-phase coded signals are valid (T and 2T).

The limits for T are the same as used for the bit check. They can be programmed in the LIMIT-register (Lim_min and Lim_max, see Table 11 and Table 12).

The limits for 2T are calculated as follows:

$$\text{Lower limit of } 2T: \text{Lim_min_}2T = (\text{Lim_min} + \text{Lim_max}) - (\text{Lim_max} - \text{Lim_min})/2$$

$$\text{Upper limit of } 2T: \text{Lim_max_}2T = (\text{Lim_min} + \text{Lim_max}) + (\text{Lim_max} - \text{Lim_min})/2$$

(If the result for “Lim_min_2T” or “Lim_max_2T” is not an integer value, it will be round up.)

The data clock is available, after the data clock control logic has detected the distance $2T$ (Start bit) and is issued with the delay t_{Delay} after the edge on Pin DATA (see figure 22).

If the data clock control logic detects a timing or logical error (Manchester code violation), like illustrated in Figure 23 and Figure 24, it stops the output of the data clock. The receiver remains in receiving mode and starts with the bit check. If the bit check was successful and the start bit has been detected, the data clock control logic starts again with the generation of the data clock (see Figure 25).

It is recommended to use the function of the data clock only in conjunction with the bit check 3, 6 or 9. If the bit check is set to 0 or the receiver is set to receiving mode via the Pin POLLING/_ON, the data clock is available if the data clock control logic has detected the distance $2T$ (Start bit).

Note that for Bi-phase-coded signals, the data clock is issued at the end of the bit.

Figure 22. Timing Diagram of the Data Clock

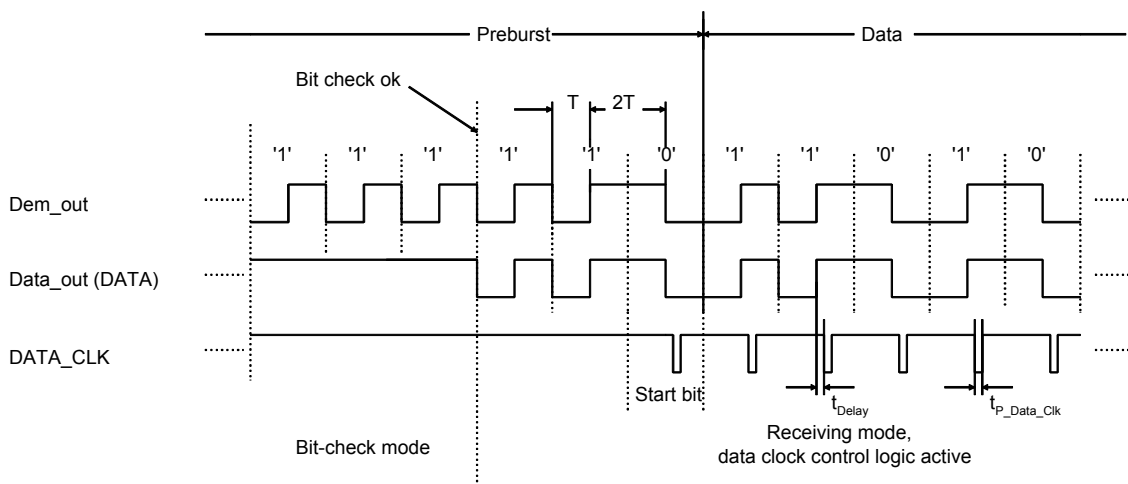

Figure 23. Data Clock Disappears Because of a Timing Error

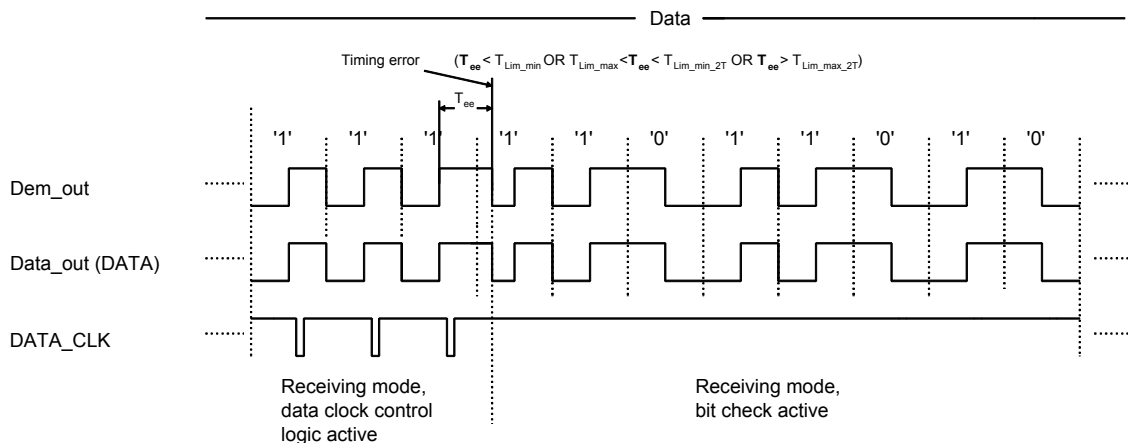

Figure 24. Data Clock Disappears Because of a Logical Error

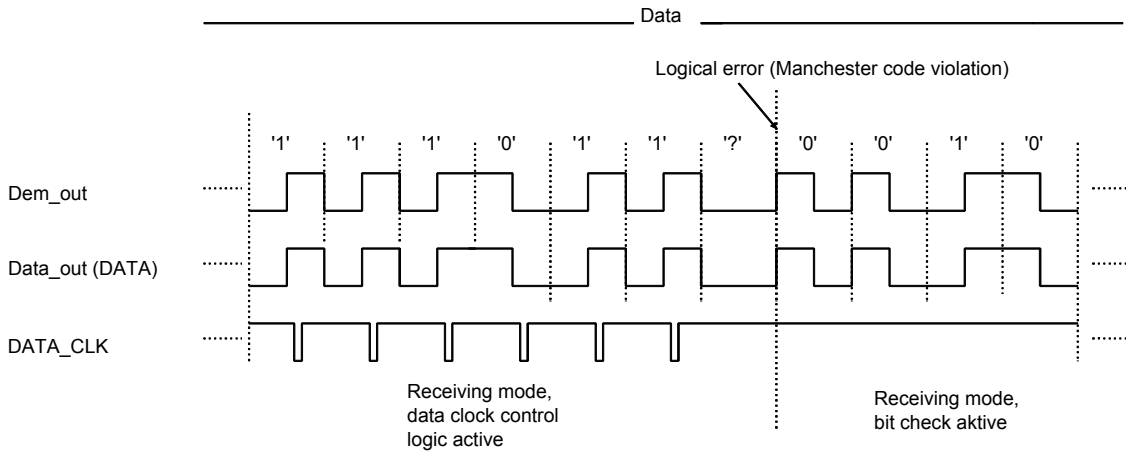
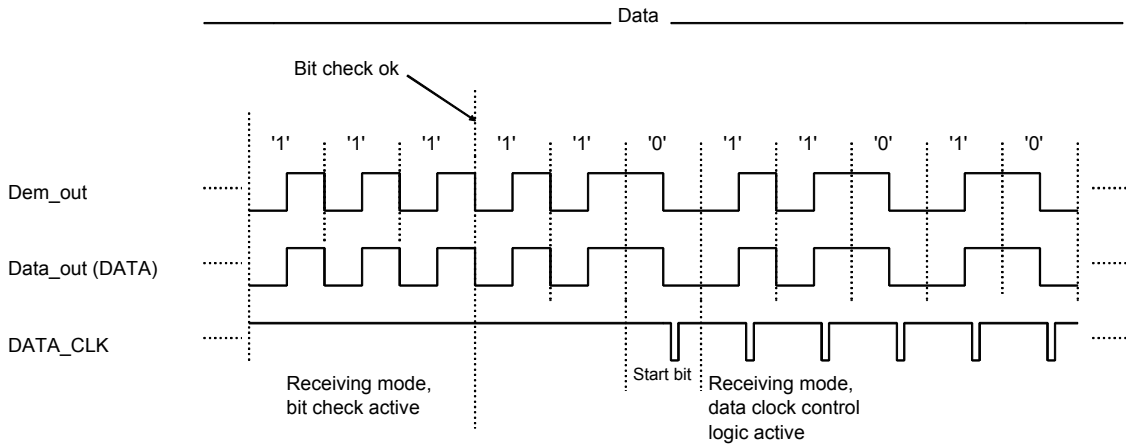

Figure 25. Output of the Data Clock After a Successful Bit Check



The delay of the data clock is calculated as follows:

$$t_{\text{Delay}} = t_{\text{Delay1}} + t_{\text{Delay2}}$$

t_{Delay1} is the delay between the internal signals Data_Out and Data_In. For the rising edge, t_{Delay1} depends on the capacitive load C_L at Pin DATA and the external pull-up resistor R_{pup} . For the falling edge, t_{Delay1} depends additionally on the external voltage V_X (see Figure 26, Figure 27 and Figure 34). When the level of Data_In is equal to the level of Data_Out, the data clock is issued after an additional delay t_{Delay2} .

Note that the capacitive load at Pin DATA is limited. If the maximum tolerated capacitive load at Pin DATA is exceeded, the data clock disappears (see section “Data Interface”).

Figure 26. Timing Characteristic of the Data Clock (Rising Edge on Pin DATA)

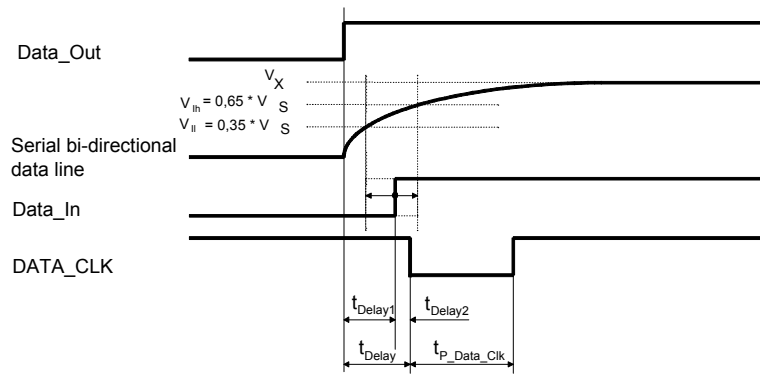
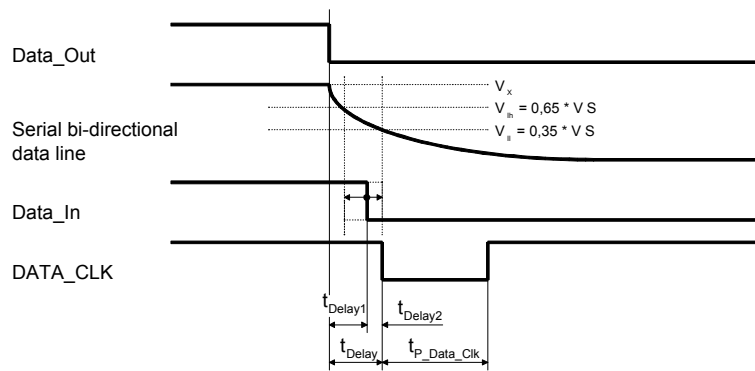

Figure 27. Timing Characteristic of the Data Clock (Falling Edge of the Pin DATA)



Digital Noise Suppression

Automatic Noise Suppression (see Figure 29)

After a data transmission, digital noise appears on the data output (see Figure 28). To prevent that digital noise keeps the connected microcontroller busy, it can be suppressed in two different ways.

If the bit Noise_Disable (Table 10) in the OPMODE register is set to 1 (default), the receiver changes to bit-check mode at the end of a valid data stream. The digital noise is suppressed and the level at Pin DATA is High in that case. The receiver changes back to receiving mode, if the bit check was successful.

This way to suppress the noise is recommended if the data stream is Manchester or Bi-phase coded and is active after power on.

Figure 30 illustrates the behavior of the data output at the end of a data stream. Note that if the last period of the data stream is a high period (rising edge to falling edge), a pulse occurs on Pin DATA. The length of the pulse depends on the selected baud-rate range.

Figure 28. Output of Digital Noise at the End of the Data Stream

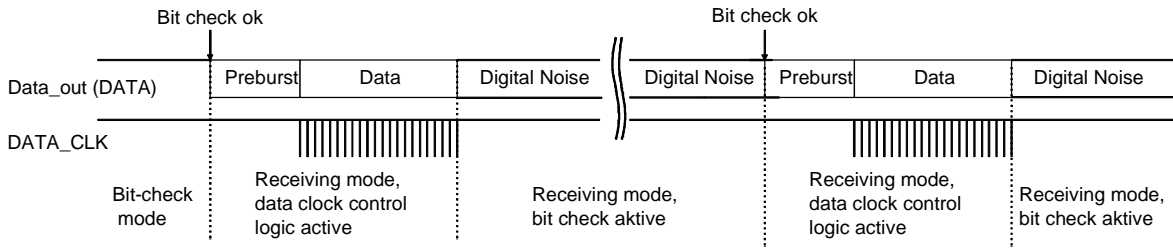

Figure 29. Automatic Noise Suppression

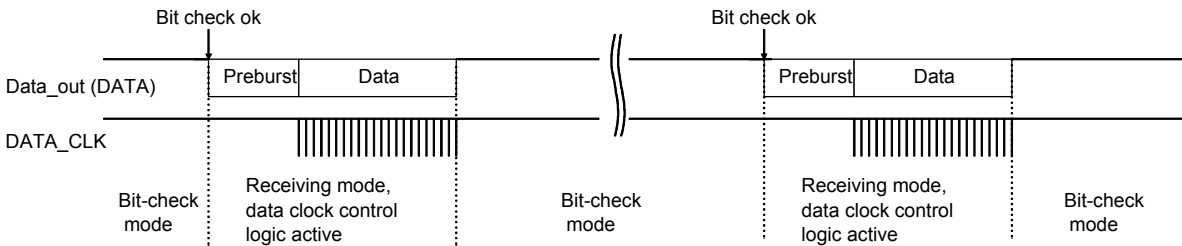
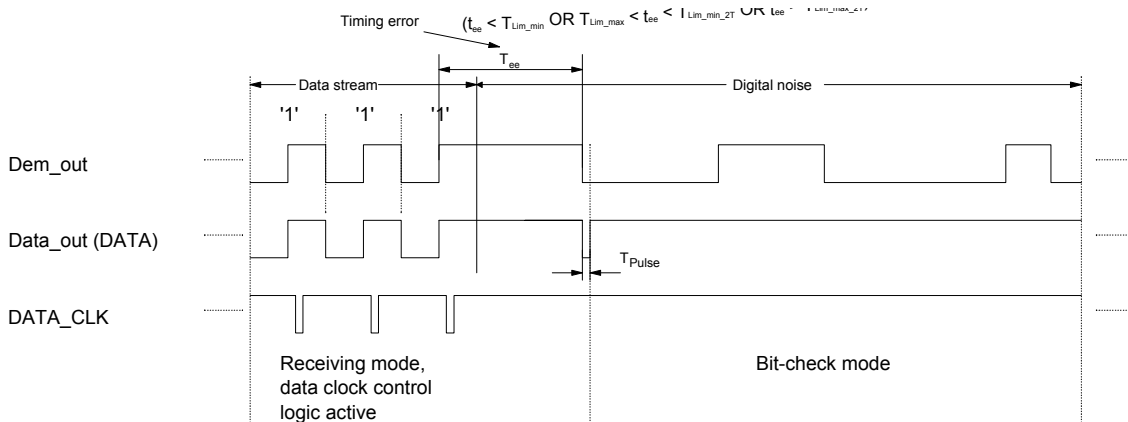

Figure 30. Occurrence of a Pulse at the End of the Data Stream



Controlled Noise Suppression by the Microcontroller (see Figure 31)

If the bit Noise_Disable (see Table 10) in the OPMODE register is set to 0, digital noise appears at the end of a valid data stream. To suppress the noise, the Pin POLLING/_ON must be set to Low. The receiver remains in receiving mode. Then, the OFF-command causes the change to the start-up mode. The programmed sleep time (see Table 8) will not be executed because the level at Pin POLLING/_ON is low, but the bit check is active in that case. The OFF-command activates the bit check also if the Pin POLLING/_ON is held to Low. The receiver changes back to receiving mode if the bit check was successful. To activate the polling mode at the end of the data transmission, the Pin POLLING/_ON must be set to High.

This way to suppress the noise is recommended if the data stream is not Manchester or Bi-phase coded.

Figure 31. Controlled Noise Suppression

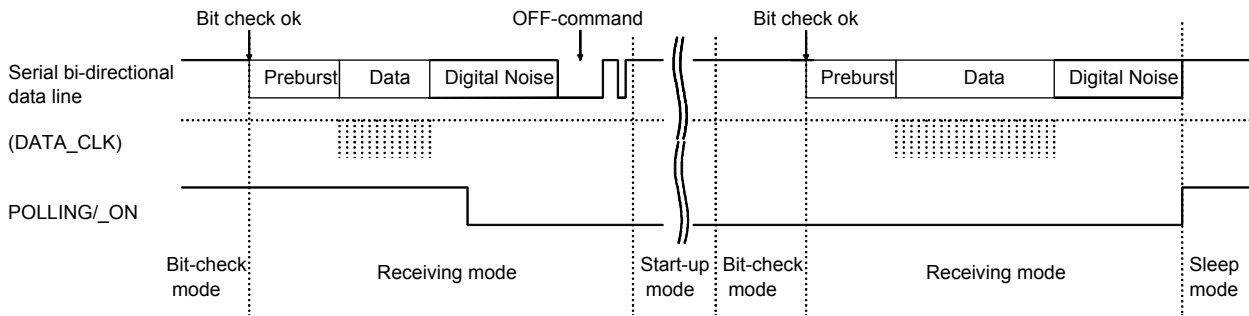

Configuration of the Receiver

The T5743 receiver is configured via two 12-bit RAM registers called OPMODE and LIMIT. The registers can be programmed by means of the bidirectional DATA port. If the register contents have changed due to a voltage drop, this condition is indicated by a certain output pattern called reset marker (RM). The receiver must be reprogrammed in that case. After a power-on reset (POR), the registers are set to default mode. If the receiver is operated in default mode, there is no need to program the registers. Table 4 shows the structure of the registers. According to Table 2 bit 1 defines if the receiver is set back to polling mode via the OFF-command (see section “Receiving Mode”) or if it is programmed. Bit 2 represents the register address. It selects the appropriate register to be programmed. To get a high programming reliability, Bit15 (Stop bit), at the end of the programming operation, must be set to 0.

Table 2. Effect of Bit 1 and Bit 2 on Programming the Registers

Bit 1	Bit 2	Action
1	x	The receiver is set back to polling mode (OFF command)
0	1	The OPMODE register is programmed
0	0	The LIMIT register is programmed

Table 3. Effect of Bit 15 on Programming the Register

Bit 15	Action
0	The values will be written into the register (OPMODE or LIMIT)
1	The values will not be written into the register

Table 4. Effect of the Configuration Words Within the Registers

Bit 1	Bit 2	Bit 3	Bit 4	Bit 5	Bit 6	Bit 7	Bit 8	Bit 9	Bit 10	Bit 11	Bit 12	Bit 13	Bit 14	Bit 15
OFF-command														
1														
OPMODE register														
0	1	BR_Range		N _{Bit-check}		Modulation	Sleep					X Sleep	Noise Suppression	0
		Baud1	Baud0	BitChk1	BitChk0	ASK/_FSK	Sleep4	Sleep3	Sleep2	Sleep1	Sleep0	X _{SleepStd}	Noise_Disable	
Default values of Bit 3...14		0	0	0	1	0	0	0	1	1	0	0	1	
LIMIT register														
0	0	Lim_min						Lim_max						0
		Lim_min5	Lim_min4	Lim_min3	Lim_min2	Lim_min1	Lim_min0	Lim_max5	Lim_max4	Lim_max3	Lim_max2	Lim_max1	Lim_max0	
Default values of Bit 3...14		0	1	0	1	0	1	1	0	1	0	0	1	

Table 5 to Table 12 illustrate the effect of the individual configuration words. The default configuration is highlighted for each word.

BR_Range sets the appropriate baud-rate range and simultaneously defines XLim. XLim is used to define the bit-check limits T_{Lim_min} and T_{Lim_max} as shown in table 11 and table 12.

Table 5. Effect of the Configuration Word BR_Range

BR_Range		Baud-Rate Range/Extension Factor for Bit-Check Limits (XLim)
Baud1	Baud0	
0	0	BR_Range0 (application USA/Europe: BR_Range0 = 1.0 kBaud to 1.8 kBaud) XLim = 8 (default)
0	1	BR_Range1 (application USA/Europe: BR_Range1 = 1.8 kBaud to 3.2 kBaud) XLim = 4
1	0	BR_Range2 (application USA/Europe: BR_Range2 = 3.2 kBaud to 5.6 kBaud) XLim = 2
1	1	BR_Range3 (application USA/Europe: BR_Range3 = 5.6 kBaud to 10 kBaud) XLim = 1

Table 6. Effect of the Configuration Word N_{Bit-check}

N _{Bit-check}		Number of Bits to be Checked
BitChk1	BitChk0	
0	0	0
0	1	3 (default)
1	0	6
1	1	9

Table 7. Effect of the Configuration Bit Modulation

Modulation	Selected Modulation
ASK_FSK	
0	FSK (default)
1	ASK

Table 8. Effect of the Configuration Word Sleep

Sleep					Start Value for Sleep Counter ($T_{Sleep} = Sleep \times X_{Sleep} \times 1024 \times T_{Clk}$)
Sleep4	Sleep3	Sleep2	Sleep1	Sleep0	
0	0	0	0	0	0 (Receiver is continuously polling until a valid signal occurs)
0	0	0	0	1	1 ($T_{Sleep} \approx 2$ ms for $X_{Sleep} = 1$ in US-/European applications)
0	0	0	1	0	2
0	0	0	1	1	3
...
0	0	1	1	0	6 (USA: $T_{Sleep} = 12.52$ ms, Europe: $T_{Sleep} = 12.72$ ms) (default)
...
1	1	1	0	1	29
1	1	1	1	0	30
1	1	1	1	1	31 (Permanent sleep mode)

Table 9. Effect of the Configuration Bit XSleep

XSleep	Extension Factor for Sleep Time ($T_{Sleep} = Sleep \times X_{Sleep} \times 1024 \times T_{Clk}$)
$X_{Sleep_{Std}}$	
0	1 (default)
1	8

Table 10. Effect of the Configuration Bit Noise Suppression

Noise Suppression	Suppression of the Digital Noise at Pin DATA
Noise_Disable	
0	Noise suppression is inactive
1	Noise suppression is active (default)

Table 11. Effect of the Configuration Word Lim_min

Lim_min ⁽¹⁾ (Lim_min < 10 Is Not Applicable)						Lower Limit Value for Bit Check
Lim_min5	Lim_min4	Lim_min3	Lim_min2	Lim_min1	Lim_min0	($T_{Lim_min} = Lim_min \times Lim \times T_{Cik}$)
0	0	1	0	1	0	10
0	0	1	0	1	1	11
0	0	1	1	0	0	12
...	
0	1	0	1	0	1	21 (default) USA: $T_{Lim_min} = 342 \mu s$, Europe: $T_{Lim_min} = 348 \mu s$
...	
1	1	1	1	0	1	61
1	1	1	1	1	0	62
1	1	1	1	1	1	63

Note: 1. Lim_min is also be used to determine the margins of the data clock control logic (see section “Data Clock”).

Table 12. Effect of the Configuration Word Lim_max

Lim_max ⁽¹⁾ (Lim_max < 12 Is Not Applicable)						Upper Limit Value for Bit Check
Lim_max5	Lim_max4	Lim_max3	Lim_max2	Lim_max1	Lim_max0	($T_{Lim_max} = (Lim_max - 1) \times XLim \times T_{Cik}$)
0	0	1	1	0	0	12
0	0	1	1	0	1	13
0	0	1	1	1	0	14
...	
1	0	1	0	0	1	41 (default) USA: $T_{Lim_max} = 652 \mu s$, Europe: $T_{Lim_max} = 662 \mu s$
...	
1	1	1	1	0	1	61
1	1	1	1	1	0	62
1	1	1	1	1	1	63

Note: 1. Lim_max is also be used to determine the margins of the data clock control logic (see section “Data Clock”).

Conservation of the Register Information

The T5743 implies an integrated power-on reset and brown-out detection circuitry to provide a mechanism to preserve the RAM register information.

According to Figure 32, a power-on reset (POR) is generated if the supply voltage V_S drops below the threshold voltage $V_{ThReset}$. The default parameters are programmed into the configuration registers in that condition. Once V_S exceeds $V_{ThReset}$ the POR is cancelled after the minimum reset period t_{Rst} . A POR is also generated when the supply voltage of the receiver is turned on.

To indicate that condition, the receiver displays a reset marker (RM) at Pin DATA after a reset. The RM is represented by the fixed frequency f_{RM} at a 50% duty-cycle. RM can be cancelled via a Low pulse t_1 at Pin DATA.

The RM implies the following characteristics:

- f_{RM} is lower than the lowest feasible frequency of a data signal. By this means, RM cannot be misinterpreted by the connected microcontroller.
- If the receiver is set back to polling mode via Pin DATA, RM cannot be cancelled by accident if t1 is applied according to the proposal in the section “Programming the Configuration Registers”.

By means of that mechanism the receiver cannot lose its register information without communicating that condition via the reset marker RM.

Figure 32. Generation of the Power-on Reset

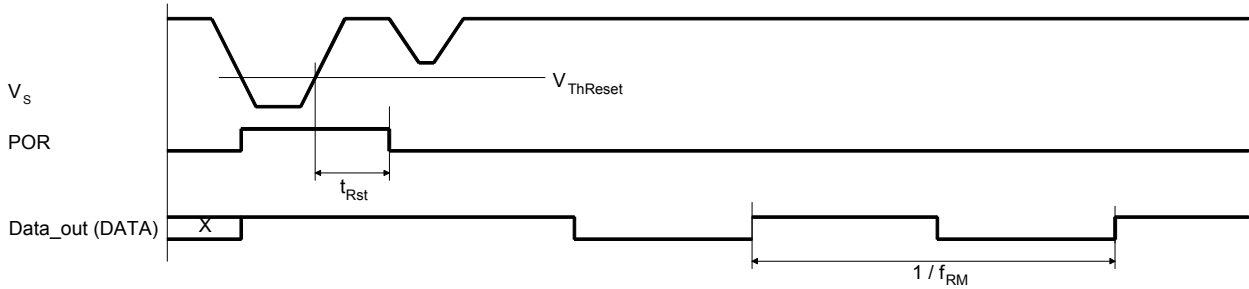

Programming the Configuration Register

Figure 33. Timing of the Register Programming

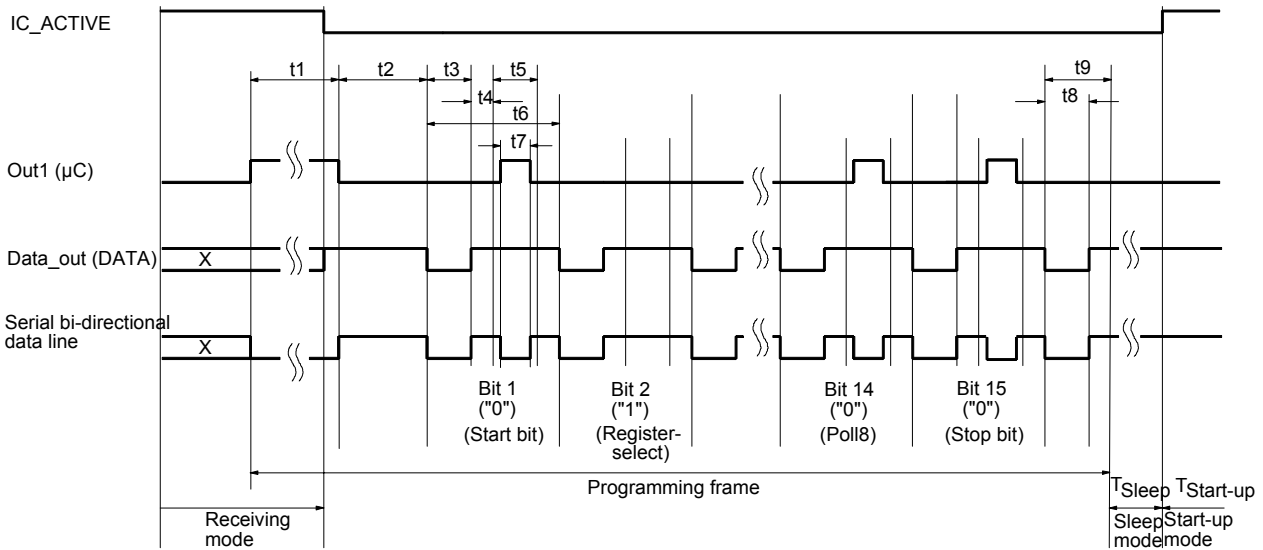
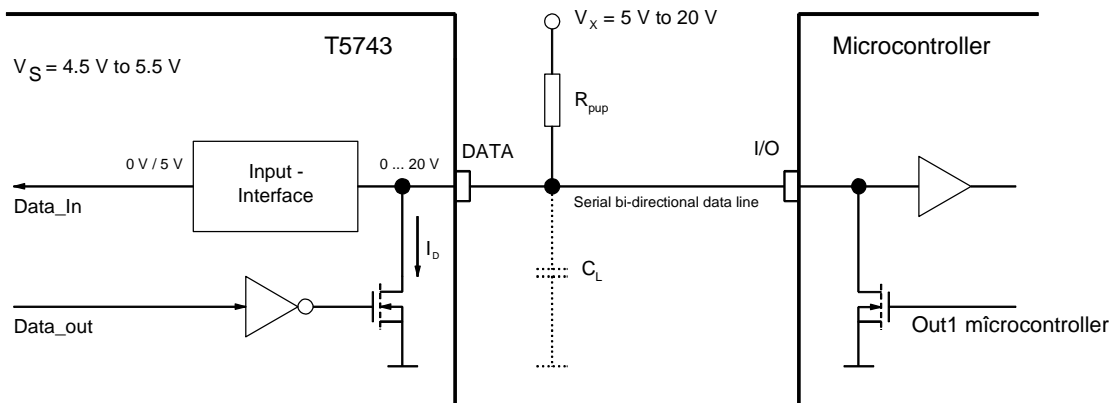

Figure 34. Data Interface



The configuration registers are programmed serially via the bi-directional data line according to Figure 33 and Figure 34.

To start programming, the serial data line DATA is pulled to Low for the time period t_1 by the microcontroller. When DATA has been released, the receiver becomes the master device. When the programming delay period t_2 has elapsed, it emits 15 subsequent synchronization pulses with the pulse length t_3 . After each of these pulses, a programming window occurs. The delay until the program window starts is determined by t_4 , the duration is defined by t_5 . Within the programming window, the individual bits are set. If the microcontroller pulls down Pin DATA for the time period t_7 during t_5 , the according bit is set to "0". If no programming pulse t_7 is issued, this bit is set to "1". All 15 bits are subsequently programmed this way. The time frame to program a bit is defined by t_6 .

Bit 15 is followed by the equivalent time window t_9 . During this window, the equivalence acknowledge pulse t_8 (E_Ack) occurs if the just programmed mode word is equivalent to the mode word that was already stored in that register. E_Ack should be used to verify that the mode word was correctly transferred to the register. The register must be programmed twice in that case.

Programming of a register is possible both in sleep- and in active-mode of the receiver.

During programming, the LNA, LO, lowpass filter IF-amplifier and the FSK/ASK Manchester demodulator are disabled.

The programming start pulse t_1 initiates the programming of the configuration registers. If bit 1 is set to "1", it represents the OFF-command to set the receiver back to polling mode at the same time. For the length of the programming start pulse t_1 , the following convention should be considered:

- $t_1(\text{min}) < t_1 < 5632 \times T_{\text{Clk}}$: $t_1(\text{min})$ is the minimum specified value for the relevant BR_Range

Programming respectively OFF-command is initiated if the receiver is not in reset mode. If the receiver is in reset mode, programming respectively Off-command is not initiated and the reset marker RM is still present at Pin DATA.

This period is generally used to switch the receiver to polling mode or to start the programming of a register. In reset condition, RM is not cancelled by accident.

- $t_1 > 7936 \times T_{\text{Clk}}$

Figure 36. Application Circuit: $f_{RF} = 315$ MHz without SAW Filter

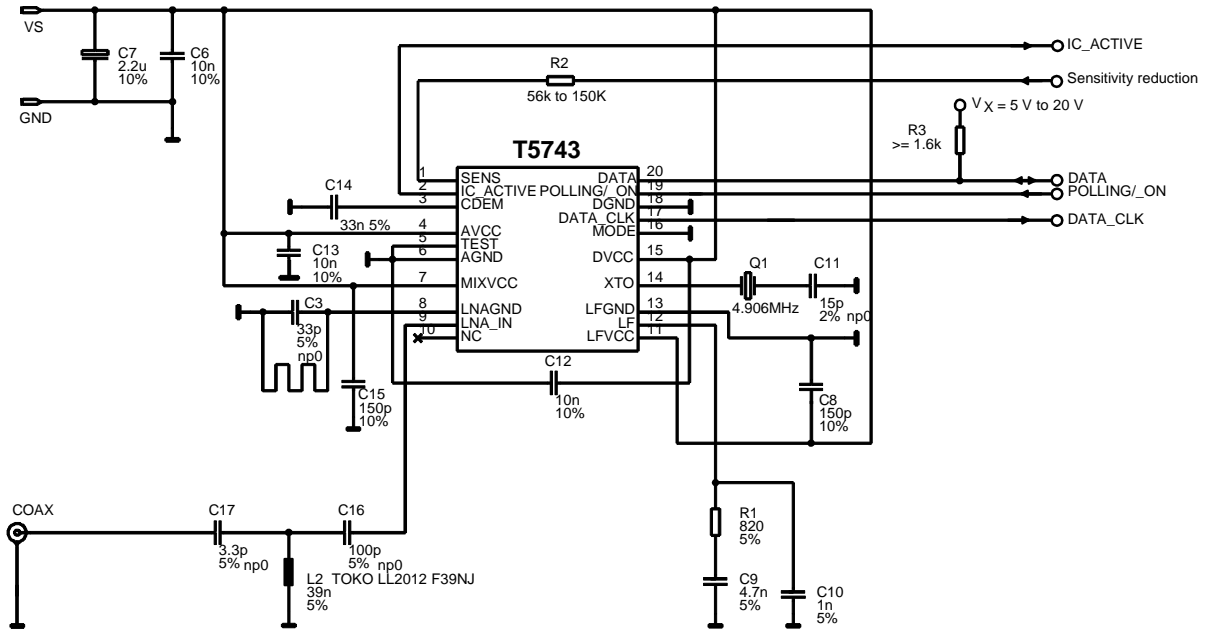
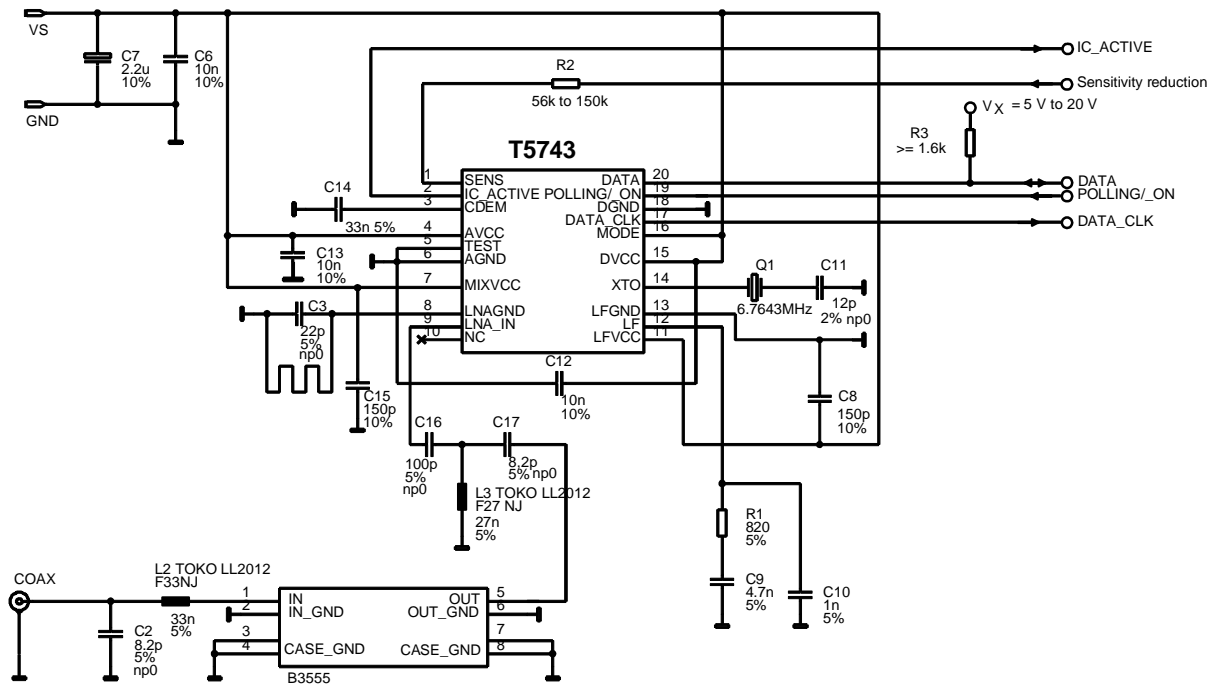

Figure 37. Application Circuit: $f_{RF} = 433.92$ MHz with SAW Filter



Electrical Characteristics

All parameters refer to GND, $T_{amb} = -40^{\circ}\text{C}$ to $+105^{\circ}\text{C}$, $V_S = 4.5\text{ V}$ to 5.5 V , $f_0 = 433.92\text{ MHz}$ and $f_0 = 315\text{ MHz}$, unless otherwise specified.
(For typical values: $V_S = 5\text{ V}$, $T_{amb} = 25^{\circ}\text{C}$)

Parameter	Test Conditions	Symbol	6.76438 MHz Osc. (MODE: 1)			4.90625 MHz Osc. (MODE: 0)			Variable Oscillator			Unit	
			Min.	Typ.	Max.	Min.	Typ.	Max.	Min.	Typ.	Max.		
Basic Clock Cycle of the Digital Circuitry													
Basic clock cycle	MODE = 0 (USA) MODE = 1 (Europe)	T_{Clk}	2.0697		2.0697	2.0383		2.0383	$1/f_{XTO}/10$ $1/f_{XTO}/14$		$1/f_{XTO}/10$ $1/f_{XTO}/14$	μs μs	
Extended basic clock cycle	BR_Range0	T_{XClk}	16.6		16.6	16.3		16.3	$8 \times T_{Clk}$		$8 \times T_{Clk}$	μs	
	BR_Range1		8.3		8.3	8.2		8.2	$4 \times T_{Clk}$		$4 \times T_{Clk}$	μs	
	BR_Range2		4.1		4.1	4.1		4.1	$2 \times T_{Clk}$		$2 \times T_{Clk}$	μs	
	BR_Range3		2.1		2.1	2.0		2.0	$1 \times T_{Clk}$		$1 \times T_{Clk}$	μs	
Polling Mode													
Sleep time (see Figure 10, Figure 19, and Figure 33)	Sleep and XSleep are defined in the OPMODE register	T_{Sleep}	Sleep \times $X_{Sleep} \times$ $1024 \times$ 2.0697		Sleep \times $X_{Sleep} \times$ $1024 \times$ 2.0697	Sleep \times $X_{Sleep} \times$ $1024 \times$ 2.0383		Sleep \times $X_{Sleep} \times$ $1024 \times$ 2.0383	Sleep \times $X_{Sleep} \times$ $1024 \times T_{Clk}$		Sleep \times $X_{Sleep} \times$ $1024 \times T_{Clk}$	ms	
Start-up time (see Figure 10, and Figure 11)	BR_Range0	$T_{Startup}$	1855		1855	1827		1827	896.5		896.5	μs	
	BR_Range1		1061		1061	1045		1045	512.5		512.5	μs	
	BR_Range2		1061		1061	1045		1045	512.5		512.5	μs	
	BR_Range3		663		663	653		653	$320.5 \times T_{Clk}$		$320.5 \times T_{Clk}$	μs	
Time for bit check (see Figure 10)	Average bit-check time while polling, no RF applied (see Figure 14, and Figure 15) BR_Range0 BR_Range1 BR_Range2 BR_Range3	$T_{Bit-check}$		0.45		0.45		0.45				ms	
				0.24		0.24		0.24				ms	
				0.14		0.14		0.14					ms
				0.08		0.08		0.08					ms
Bit-check time for a valid input signal f_{Sig} , (see Figure 11) $N_{Bit-check} = 0$ $N_{Bit-check} = 3$ $N_{Bit-check} = 6$ $N_{Bit-check} = 9$	$T_{Bit-check}$								$1 \times T_{XClk}$		$1 \times T_{Clk}$	ms	
		$3/f_{Sig}$		$3.5/f_{Sig}$		$3/f_{Sig}$		$3.5/f_{Sig}$	$3/f_{Sig}$		$3.5/f_{Sig}$	ms	
		$6/f_{Sig}$		$6.5/f_{Sig}$		$6/f_{Sig}$		$6.5/f_{Sig}$	$6/f_{Sig}$		$6.5/f_{Sig}$	ms	
		$9/f_{Sig}$		$9.5/f_{Sig}$		$9/f_{Sig}$		$9.5/f_{Sig}$	$9/f_{Sig}$		$9.5/f_{Sig}$	ms	
Receiving Mode													
Intermediate frequency	MODE = 0 (USA) MODE = 1 (Europe)	f_{IF}		1.0		1.0			$f_{XTO} \times 64/314$ $f_{XTO} \times 64/432.92$			MHz MHz	
Baud-rate range	BR_Range0	BR_Range	1.0		1.8	1.0		1.8	$BR_Range0 \times 2 \mu\text{s}/T_{Clk}$			kBaud	
	BR_Range1		1.8		3.2	1.8		3.2	$BR_Range1 \times 2 \mu\text{s}/T_{Clk}$			kBaud	
	BR_Range2		3.2		5.6	3.2		5.6	$BR_Range2 \times 2 \mu\text{s}/T_{Clk}$			kBaud	
	BR_Range3		5.6		10.0	5.6		10.0	$BR_Range3 \times 2 \mu\text{s}/T_{Clk}$			kBaud	
Minimum time period between edges at Pin DATA (see Figure 7, Figure 17 and Figure 18, with the exception of parameter T_{Pulse})	BR_Range =	$t_{DATA-min}$											
	BR_Range0		165		165	163		163	$10 \times T_{XClk}$		$10 \times T_{XClk}$	μs	
	BR_Range1		83		83	81		81	$10 \times T_{XClk}$		$10 \times T_{XClk}$	μs	
	BR_Range2		41.4		41.4	40.7		40.7	$10 \times T_{XClk}$		$10 \times T_{XClk}$	μs	
BR_Range3	20.7		20.7	20.4		20.4	$10 \times T_{XClk}$		$10 \times T_{XClk}$	μs			

Electrical Characteristics (Continued)

All parameters refer to GND, $T_{amb} = -40^{\circ}\text{C}$ to $+105^{\circ}\text{C}$, $V_S = 4.5\text{ V}$ to 5.5 V , $f_0 = 433.92\text{ MHz}$ and $f_0 = 315\text{ MHz}$, unless otherwise specified.
(For typical values: $V_S = 5\text{ V}$, $T_{amb} = 25^{\circ}\text{C}$)

Parameter	Test Conditions	Symbol	6.76438 MHz Osc. (MODE: 1)			4.90625 MHz Osc. (MODE: 0)			Variable Oscillator			Unit
			Min.	Typ.	Max.	Min.	Typ.	Max.	Min.	Typ.	Max.	
Maximum Low period at Pin DATA (see Figure 7 and Figure 18)	BR_Range =	$t_{\text{DATA_L_max}}$										
	BR_Range0		2152		2152	2120		2120	$130 \times T_{\text{Clk}}$		$130 \times T_{\text{Clk}}$	μs
	BR_Range1		1076		1076	1060		1060	$130 \times T_{\text{Clk}}$		$130 \times T_{\text{Clk}}$	μs
	BR_Range2		538		538	530		530	$130 \times T_{\text{Clk}}$		$130 \times T_{\text{Clk}}$	μs
BR_Range3	270		270	265		265	$130 \times T_{\text{Clk}}$		$130 \times T_{\text{Clk}}$	μs		
Delay to activate the start-up mode (see Figure 21)		Ton1	19.7		21.8	19.4		21.5	$9.5 \times T_{\text{Clk}}$		$10.5 \times T_{\text{Clk}}$	μs
OFF- command at Pin POLLING/_ON (see Figure 20)		Ton2	16.6			16.4			$8 \times T_{\text{Clk}}$			μs
Delay to activate the sleep mode (see Figure 20)		Ton3	17.6		19.7	17.4		19.4	$8.5 \times T_{\text{Clk}}$		$9.5 \times T_{\text{Clk}}$	μs
Pulse on Pin DATA at the end of a data stream (see Figure 30)	BR_Range =	T_{Pulse}										
	BR_Range0		16.6		16.6	16.3		16.3	$8 \times T_{\text{Clk}}$		$8 \times T_{\text{Clk}}$	μs
	BR_Range1		8.3		8.3	8.2		8.2	$4 \times T_{\text{Clk}}$		$4 \times T_{\text{Clk}}$	μs
	BR_Range2		4.1		4.1	4.1		4.1	$2 \times T_{\text{Clk}}$		$2 \times T_{\text{Clk}}$	μs
BR_Range3	2.1		2.1	2.0		2.0	$1 \times T_{\text{Clk}}$		$1 \times T_{\text{Clk}}$	μs		
Configuration of the Receiver												
Frequency of the reset marker	(see Figure 31)	f_{RM}	117.9		117.9	119.8		119.8	$\frac{1}{4096 \times T_{\text{Clk}}}$		$\frac{1}{4096 \times T_{\text{Clk}}}$	Hz
Programming start pulse (see Figure 19 and Figure 33)	BR_Range =	t1										
	BR_Range0		3367		11650	3311		11470	$1624 \times T_{\text{Clk}}$		$5632 \times T_{\text{Clk}}$	μs
	BR_Range1		2277		11650	2243		11470	$1100 \times T_{\text{Clk}}$		$5632 \times T_{\text{Clk}}$	μs
	BR_Range2		1735		11650	1709		11470	$838 \times T_{\text{Clk}}$		$5632 \times T_{\text{Clk}}$	μs
	BR_Range3 after POR		1464		11650	1442		11470	$707 \times T_{\text{Clk}}$		$5632 \times T_{\text{Clk}}$	μs
Programming delay period	(see Figure 19 and Figure 33)	t2	795		798	783		786	$384.5 \times T_{\text{Clk}}$		$385.5 \times T_{\text{Clk}}$	μs
Synchronization pulse		t3	265		265	261		261	$128 \times T_{\text{Clk}}$		$128 \times T_{\text{Clk}}$	μs
Delay until of the program window starts		t4	131		131	129		129	$63.5 \times T_{\text{Clk}}$		$63.5 \times T_{\text{Clk}}$	μs
Programming window		t5	530		530	522		522	$256 \times T_{\text{Clk}}$		$256 \times T_{\text{Clk}}$	μs
Time frame of a bit (see Figure 33)		t6	1060		1060	1044		1044	$512 \times T_{\text{Clk}}$		$512 \times T_{\text{Clk}}$	μs
Programming pulse (see Figure 19 and Figure 33)		t7	132		529	130		521	$64 \times T_{\text{Clk}}$		$256 \times T_{\text{Clk}}$	μs

Electrical Characteristics (Continued)

All parameters refer to GND, $T_{amb} = -40^{\circ}\text{C}$ to $+105^{\circ}\text{C}$, $V_S = 4.5\text{ V}$ to 5.5 V , $f_0 = 433.92\text{ MHz}$ and $f_0 = 315\text{ MHz}$, unless otherwise specified. (For typical values: $V_S = 5\text{ V}$, $T_{amb} = 25^{\circ}\text{C}$)

Parameter	Test Conditions	Symbol	6.76438 MHz Osc. (MODE: 1)			4.90625 MHz Osc. (MODE: 0)			Variable Oscillator			Unit
			Min.	Typ.	Max.	Min.	Typ.	Max.	Min.	Typ.	Max.	
Equivalent acknowledge pulse: E_Ack (see Figure 33)		t8	265		265	261		261	$128 \times T_{Clk}$		$128 \times T_{Clk}$	μs
Equivalent time window (see Figure 33)		t9	534		534	526		526	$258 \times T_{Clk}$		$258 \times T_{Clk}$	μs
OFF-bit programming window (see Figure 19)		t10	930		930	916		916	$449.5 \times T_{Clk}$		$449.5 \times T_{Clk}$	μs
Data Clock												
Minimum delay time between edge at DATA and DATA_CLK (see Figure 26 and Figure 27)	BR_Range =	t _{Delay2}	0		16.6	0		16.3	0		$1 \times T_{XClk}$	μs
	BR_Range0		0		8.3	0		8.2	0		$1 \times T_{XClk}$	μs
	BR_Range1		0		4.15	0		4.08	0		$1 \times T_{XClk}$	μs
	BR_Range2		0		2.07	0		2.04	0		$1 \times T_{XClk}$	μs
Pulswidth of negative pulse at Pin DATA_CLK (see Figure 26 and Figure 27)	BR_Range =	t _{P_DATA_CLK}	66.2		66.2	65.2		65.2	$4 \times T_{XClk}$		$4 \times T_{XClk}$	μs
	BR_Range0		33.1		33.1	32.6		32.6	$4 \times T_{XClk}$		$4 \times T_{XClk}$	μs
	BR_Range1		16.56		16.56	16.3		16.3	$4 \times T_{XClk}$		$4 \times T_{XClk}$	μs
	BR_Range2		8.3		8.3	8.2		8.2	$4 \times T_{XClk}$		$4 \times T_{XClk}$	μs

Electrical Characteristics (Continued)

All parameters refer to GND, $T_{amb} = -40^{\circ}\text{C}$ to $+105^{\circ}\text{C}$, $V_S = 4.5\text{ V}$ to 5.5 V , $f_0 = 433.92\text{ MHz}$ and $f_0 = 315\text{ MHz}$, unless otherwise specified. (For typical values: $V_S = 5\text{ V}$, $T_{amb} = 25^{\circ}\text{C}$)

Parameters	Test Conditions	Symbol	Min.	Typ.	Max.	Unit
Current consumption	Sleep mode (XTO and polling logic active)	I _{Soff}		170	276	μA
	IC active (start-up-, bit check-, receiving mode) Pin DATA = H FSK ASK	I _{Son}		7.5 7.1	9.1 8.7	mA mA
LNA Mixer (Input Matched According to Figure 6)						
Third-order intercept point	LNA/mixer/IF amplifier	IIP3		-28		dBm
LO spurious emission at RF _{in}	Required according to I-ETS 300220	I _{S_LORF}		-73	-57	dBm
Noise figure LNA and mixer (DSB)		NF		7		dB
LNA_IN input impedance	at 433.92 MHz at 315 MHz	Z _{i_LNA_IN}		1.0 1.56 1.3 1.0		k Ω pF k Ω pF
1 dB compression point (LNA, mixer, IF amplifier)	Referred to RF _{in}	IP _{1db}		-40		dBm

Electrical Characteristics (Continued)

All parameters refer to GND, $T_{amb} = -40^{\circ}\text{C}$ to $+105^{\circ}\text{C}$, $V_S = 4.5\text{ V}$ to 5.5 V , $f_0 = 433.92\text{ MHz}$ and $f_0 = 315\text{ MHz}$, unless otherwise specified.
(For typical values: $V_S = 5\text{ V}$, $T_{amb} = 25^{\circ}\text{C}$)

Parameters	Test Conditions	Symbol	Min.	Typ.	Max.	Unit		
Maximum input level	$\text{BER} \leq 10^{-3}$, FSK mode ASK mode	P_{in_max}			-22 -20	dBm dBm		
Local Oscillator								
Operating frequency range VCO		f_{VCO}	299		449	MHz		
Phase noise VCO/LO	$f_{osc} = 432.92\text{ MHz}$ at 1 MHz at 10 MHz	L (fm)		-93 -113	-90 -110	dBc/Hz dBc/Hz		
Spurious of the VCO	at $\pm f_{XTO}$			-55	-47	dBc		
VCO gain		K_{VCO}		190		MHz/V		
Loop bandwidth of the PLL	For best LO noise (design parameter) $R1 = 820\ \Omega$ $C9 = 4.7\text{ nF}$ $C10 = 1\text{ nF}$	B_{Loop}		100		kHz		
Capacitive load at Pin LF	The capacitive load at Pin LF is limited if bit check is used. The limitation therefore also applies to self polling.	C_{LF_tot}			10	nF		
XTO operating frequency	XTO crystal frequency, appropriate load capacitance must be connected to XTAL $f_{XTAL} = 6.764375\text{ MHz (EU)}$ $f_{XTAL} = 4.90625\text{ MHz (US)}$	f_{XTO}	-30 ppm	f_{XTAL}	+30 ppm	MHz		
Series resonance resistor of the crystal	$f_{XTO} = 6.764\text{ MHz}$, $f_{XTO} = 4.906\text{ MHz}$	R_S			150 220	Ω Ω		
Static capacitance at Pin XTO to GND		C_0			6.5	pF		
Analog Signal Processing								
Input sensitivity ASK 300 kHz IF-filter	Input matched according to Figure 6 ASK (level of carrier) $\text{BER} \leq 10^{-3}$, $\text{BW} = 300\text{ kHz}$ $f_{in} = 433.92\text{ MHz}/315\text{ MHz}$ $V_S = 5\text{ V}$, $T_{amb} = 25^{\circ}\text{C}$, $f_{IF} = 1\text{ MHz}$ BR_Range0 BR_Range1 BR_Range2 BR_Range3	P_{Ref_ASK}			-109 -107 -106 -104	-111 -109 -110 -106	-113 -111 -110 -108	dBm dBm dBm dBm

Electrical Characteristics (Continued)

All parameters refer to GND, $T_{amb} = -40^{\circ}\text{C}$ to $+105^{\circ}\text{C}$, $V_S = 4.5\text{ V}$ to 5.5 V , $f_0 = 433.92\text{ MHz}$ and $f_0 = 315\text{ MHz}$, unless otherwise specified.
(For typical values: $V_S = 5\text{ V}$, $T_{amb} = 25^{\circ}\text{C}$)

Parameters	Test Conditions	Symbol	Min.	Typ.	Max.	Unit		
Input sensitivity ASK 600 kHz IF-filter	Input matched according to Figure 6 ASK (level of carrier) $BER \leq 10^{-3}$, $BW = 600\text{ kHz}$ $f_{in} = 433.92\text{ MHz}/315\text{ MHz}$ $V_S = 5\text{ V}$, $T_{amb} = 25^{\circ}\text{C}$, $f_{IF} = 1\text{ MHz}$ BR_Range0 BR_Range1 BR_Range2 BR_Range3	P_{Ref_ASK}	-108	-110	-112	dBm		
			-106.5	-108.5	-110.5	dBm		
			-106	-108	-110	dBm		
			-104	-106	-108	dBm		
Sensitivity variation ASK for the full operating range compared to $T_{amb} = 25^{\circ}\text{C}$, $V_S = 5\text{ V}$	300 kHz and 600 kHz version $f_{in} = 433.92\text{ MHz}/315\text{ MHz}$ $f_{IF} = 1\text{ MHz}$, $P_{ASK} = P_{Ref_ASK} + \Delta P_{Ref}$	ΔP_{Ref}	+2.5		-1.5	dB		
Sensitivity variation ASK for full operating range including IF-filter compared to $T_{amb} = 25^{\circ}\text{C}$, $V_S = 5\text{ V}$,	300 kHz version $f_{in} = 433.92\text{ MHz}/315\text{ MHz}$ $f_{IF} = 0.89\text{ MHz}$ to 1.11 MHz $f_{IF} = 0.86\text{ MHz}$ to 1.14 MHz $P_{ASK} = P_{Ref_ASK} + \Delta P_{Ref}$	ΔP_{Ref}	+5.5		-1.5	dB		
			+7.5		-1.5	dB		
	600 kHz version $f_{in} = 433.92\text{ MHz}/315\text{ MHz}$ $f_{IF} = 0.79\text{ MHz}$ to 1.21 MHz $f_{IF} = 0.73\text{ MHz}$ to 1.27 MHz $P_{ASK} = P_{Ref_ASK} + \Delta P_{Ref}$	ΔP_{Ref}	+5.5		-1.5	dB		
			+7.5		-1.5	dB		
Input sensitivity FSK 300 kHz IF-filter	Input matched according to Figure 6 $BER \leq 10^{-3}$, $BW = 300\text{ kHz}$ $f_{in} = 433.92\text{ MHz}/315\text{ MHz}$ $V_S = 5\text{ V}$, $T_{amb} = 25^{\circ}\text{C}$ $f_{IF} = 1\text{ MHz}$							
			BR_Range0 $df = \pm 16\text{ kHz}$ $df = \pm 10\text{ kHz}$ to $\pm 30\text{ kHz}$	P_{Ref_FSK}	-101	-104	-105.5	dBm
					-99		-105.5	dBm
			BR_Range1 $df = \pm 16\text{ kHz}$ $df = \pm 10\text{ kHz}$ to $\pm 30\text{ kHz}$	P_{Ref_FSK}	-99	-102	-103.5	dBm
					-97		-103.5	dBm
BR_Range2 $df = \pm 16\text{ kHz}$ $df = \pm 10\text{ kHz}$ to $\pm 30\text{ kHz}$	P_{Ref_FSK}	-97.5	-100.5	-102	dBm			
		-95.5		-102	dBm			
BR_Range3 $df = \pm 16\text{ kHz}$ $df = \pm 10\text{ kHz}$ to $\pm 30\text{ kHz}$	P_{Ref_FSK}	-95.5	-98.5	-100	dBm			
		-93.5		-100	dBm			

Electrical Characteristics (Continued)

All parameters refer to GND, $T_{amb} = -40^{\circ}\text{C}$ to $+105^{\circ}\text{C}$, $V_S = 4.5\text{ V}$ to 5.5 V , $f_0 = 433.92\text{ MHz}$ and $f_0 = 315\text{ MHz}$, unless otherwise specified.
(For typical values: $V_S = 5\text{ V}$, $T_{amb} = 25^{\circ}\text{C}$)

Parameters	Test Conditions	Symbol	Min.	Typ.	Max.	Unit
Input sensitivity FSK 600 kHz IF-filter	Input matched according to Figure 6 $BER \leq 10^{-3}$, $BW = 600\text{ kHz}$ $f_{in} = 433.92\text{ MHz}/315\text{ MHz}$ $V_S = 5\text{ V}$, $T_{amb} = 25^{\circ}\text{C}$ $f_{IF} = 1\text{ MHz}$					
	BR_Range0 $df = \pm 16\text{ kHz}$ $df = \pm 10\text{ kHz to } \pm 100\text{ kHz}$	P_{Ref_FSK}	-101 -99	-104	-105.5 -105.5	dBm dBm
	BR_Range1 $df = \pm 16\text{ kHz}$ $df = \pm 10\text{ kHz to } \pm 100\text{ kHz}$	P_{Ref_FSK}	-99 -97	-102	-103.5 -103.5	dBm dBm
	BR_Range2 $df = \pm 16\text{ kHz}$ $df = \pm 10\text{ kHz to } \pm 100\text{ kHz}$	P_{Ref_FSK}	-97.5 -95.5	-100.5	-102 -102	dBm dBm
	BR_Range3 $df = \pm 16\text{ kHz}$ $df = \pm 10\text{ kHz to } \pm 100\text{ kHz}$	P_{Ref_FSK}	-95.5 -93.5	-98.5	-100 -100	dBm dBm
Sensitivity variation FSK for the full operating range compared to $T_{amb} = 25^{\circ}\text{C}$, $V_S = 5\text{ V}$	300 kHz and 600 kHz version $f_{in} = 433.92\text{ MHz}/315\text{ MHz}$ $f_{IF} = 1\text{ MHz}$ $P_{FSK} = P_{Ref_FSK} + \Delta P_{Ref}$	ΔP_{Ref}	+3		-1.5	dB
Sensitivity variation FSK for the full operating range including IF-filter compared to $T_{amb} = 25^{\circ}\text{C}$, $V_S = 5\text{ V}$	300 kHz version $f_{in} = 433.92\text{ MHz}/315\text{ MHz}$ $f_{IF} = 0.89\text{ MHz to } 1.11\text{ MHz}$ $f_{IF} = 0.86\text{ MHz to } 1.14\text{ MHz}$ $f_{IF} = 0.82\text{ MHz to } 1.18\text{ MHz}$ $P_{FSK} = P_{Ref_FSK} + \Delta P_{Ref}$	ΔP_{Ref}	+6 +8 +11		-2 -2 -2	dB dB dB
	600 kHz version $f_{in} = 433.92\text{ MHz}/315\text{ MHz}$ $f_{IF} = 0.85\text{ MHz to } 1.15\text{ MHz}$ $f_{IF} = 0.80\text{ MHz to } 1.20\text{ MHz}$ $f_{IF} = 0.74\text{ MHz to } 1.26\text{ MHz}$ $P_{FSK} = P_{Ref_FSK} + \Delta P_{Ref}$	ΔP_{Ref}	+6 +8 +11		-2 -2 -2	dB dB dB
S/N ratio to suppress inband noise signals. Noise signals may have any modulation scheme	ASK mode	SNR_{ASK}			12	dB
	FSK mode	SNR_{FSK}			3	dB
Dynamic range RSSI ampl.		DR_{RSSI}		60		dB
Lower cut-off frequency of the data filter	$CDEM = 33\text{ nF}$ $f_{cu_DF} = \frac{1}{2 \times \pi \times 30\text{ k}\Omega \times CDEM}$	f_{cu_DF}	0.11	0.16	0.20	kHz
Recommended CDEM for best performance	BR_Range0 (default) BR_Range1 BR_Range2 BR_Range3	CDEM		39 22 12 8.2		nF nF nF nF

Electrical Characteristics (Continued)

All parameters refer to GND, $T_{amb} = -40^{\circ}\text{C}$ to $+105^{\circ}\text{C}$, $V_S = 4.5\text{ V}$ to 5.5 V , $f_0 = 433.92\text{ MHz}$ and $f_0 = 315\text{ MHz}$, unless otherwise specified.
(For typical values: $V_S = 5\text{ V}$, $T_{amb} = 25^{\circ}\text{C}$)

Parameters	Test Conditions	Symbol	Min.	Typ.	Max.	Unit
Edge-to-edge time period of the input data signal for full sensitivity	BR_Range0 (default)	t_{ee_sig}	270		1000	μs
	BR_Range1		156		560	μs
	BR_Range2		89		320	μs
	BR_Range3		50		180	μs
Upper cut-off frequency data filter	Upper cut-off frequency programmable in 4 ranges via a serial mode word	f_u				
	BR_Range0 (default)		2.8	3.4	4.0	kHz
	BR_Range1		4.8	6.0	7.2	kHz
	BR_Range2		8.0	10.0	12.0	kHz
	BR_Range3		15.0	19.0	23.0	kHz
Reduced sensitivity	R_{Sense} connected from Pin Sens to V_S , input matched according to Figure 6					dBm (peak level)
	$R_{Sense} = 56\text{ k}\Omega$, $f_{in} = 433.92\text{ MHz}$, at BW = 300 kHz at BW = 600 kHz	P_{Ref_Red}	-71 -67	-76 -72	-81 -77	dBm dBm
	$R_{Sense} = 100\text{ k}\Omega$, $f_{in} = 433.92\text{ MHz}$, at BW = 300 kHz at BW = 600 kHz		-80 -76	-85 -81	-90 -86	dBm dBm
	$R_{Sense} = 56\text{ k}\Omega$, $f_{in} = 315\text{ MHz}$, at BW = 300 kHz at BW = 600 kHz		-72 -68	-77 -73	-82 -78	dBm dBm
	$R_{Sense} = 100\text{ k}\Omega$, $f_{in} = 315\text{ MHz}$, at BW = 300 kHz at BW = 600 kHz		-81 -77	-86 -82	-91 -87	dBm dBm
Reduced sensitivity variation over full operating range	$R_{Sense} = 56\text{ k}\Omega$	ΔP_{Red}	5	0	0	dB
	$R_{Sense} = 100\text{ k}\Omega$ $P_{Red} = P_{Ref_Red} + \Delta P_{Red}$		6	0	0	dB
Reduced sensitivity variation for different values of R_{Sense}	Values relative to $R_{Sense} = 56\text{ k}\Omega$					
	$R_{Sense} = 56\text{ k}\Omega$	ΔP_{Red}	0			dB
	$R_{Sense} = 68\text{ k}\Omega$	ΔP_{Red}	-3.5			dB
	$R_{Sense} = 82\text{ k}\Omega$	ΔP_{Red}	-6.0			dB
	$R_{Sense} = 100\text{ k}\Omega$	ΔP_{Red}	-9.0			dB
	$R_{Sense} = 120\text{ k}\Omega$	ΔP_{Red}	-11.0			dB
	$R_{Sense} = 150\text{ k}\Omega$ $P_{Red} = P_{Ref_Red} + \Delta P_{Red}$	ΔP_{Red}	-13.5			dB
Threshold voltage for reset		$V_{ThRESET}$	1.95	2.8	3.75	V

Electrical Characteristics (Continued)

All parameters refer to GND, $T_{amb} = -40^{\circ}\text{C}$ to $+105^{\circ}\text{C}$, $V_S = 4.5\text{ V}$ to 5.5 V , $f_0 = 433.92\text{ MHz}$ and $f_0 = 315\text{ MHz}$, unless otherwise specified.
(For typical values: $V_S = 5\text{ V}$, $T_{amb} = 25^{\circ}\text{C}$)

Parameters	Test Conditions	Symbol	Min.	Typ.	Max.	Unit
Digital Ports						
Data output						
- Saturation voltage Low	$I_{ol} \leq 12\text{ mA}$	V_{ol}		0.35	0.8	V
	$I_{ol} = 2\text{ mA}$	V_{ol}		0.08	0.3	V
- max voltage at Pin DATA		V_{oh}			20	V
- quiescent current	$V_{oh} = 20\text{ V}$	I_{qu}			20	μA
- short-circuit current	$V_{ol} = 0.8\text{ V}$ to 20 V	I_{ol_lim}	13	30	45	mA
- ambient temperature in case of permanent short-circuit	$V_{oh} = 0\text{ V}$ to 20 V	t_{amb_sc}			85	$^{\circ}\text{C}$
Data input						
- Input voltage Low		V_{ll}			$0.35 \times V_S$	V
- Input voltage High		V_{ich}	$0.65 \times V_S$			V
DATA_CLK output						
- Saturation voltage Low	IDATA_CLK = 1 mA	V_{ol}	$V_S - 0.4\text{ V}$	0.1	0.4	V
- Saturation voltage High	IDATA_CLK = -1 mA	V_{oh}		$V_S - 0.15\text{ V}$		V
IC_ACTIVE output						
- Saturation voltage Low	IIC_ACTIVE = 1 mA	V_{ol}	$V_S - 0.4\text{ V}$	0.1	0.4	V
- Saturation voltage High	IIC_ACTIVE = -1 mA	V_{oh}		$V_S - 0.15\text{ V}$		V
POLLING/_ON input						
- Low level input voltage	Receiving mode	V_{ll}			$0.2 \times V_S$	V
- High level input voltage	Polling mode	V_{lh}	$0.8 \times V_S$			V
MODE input						
- Low level input voltage	Division factor = 10	V_{ll}			$0.2 \times V_S$	V
- High level input voltage	Division factor = 14	V_{lh}	$0.8 \times V_S$			V
TEST input						
- Low level input voltage	Test input must always be set to Low	V_{ll}			$0.2 \times V_S$	V

Ordering Information

Extended Type Number	Package	Remarks
T5743P3-TG	SO20	Tube, IF bandwidth of 300 kHz
T5743P3-TGQ	SO20	Taped and reeled, IF bandwidth of 300 kHz
T5743P6-TG	SO20	Tube, IF bandwidth of 600 kHz
T5743P6-TGQ	SO20	Taped and reeled, IF bandwidth of 600 kHz

Package Information

Package SO20

Dimensions in mm

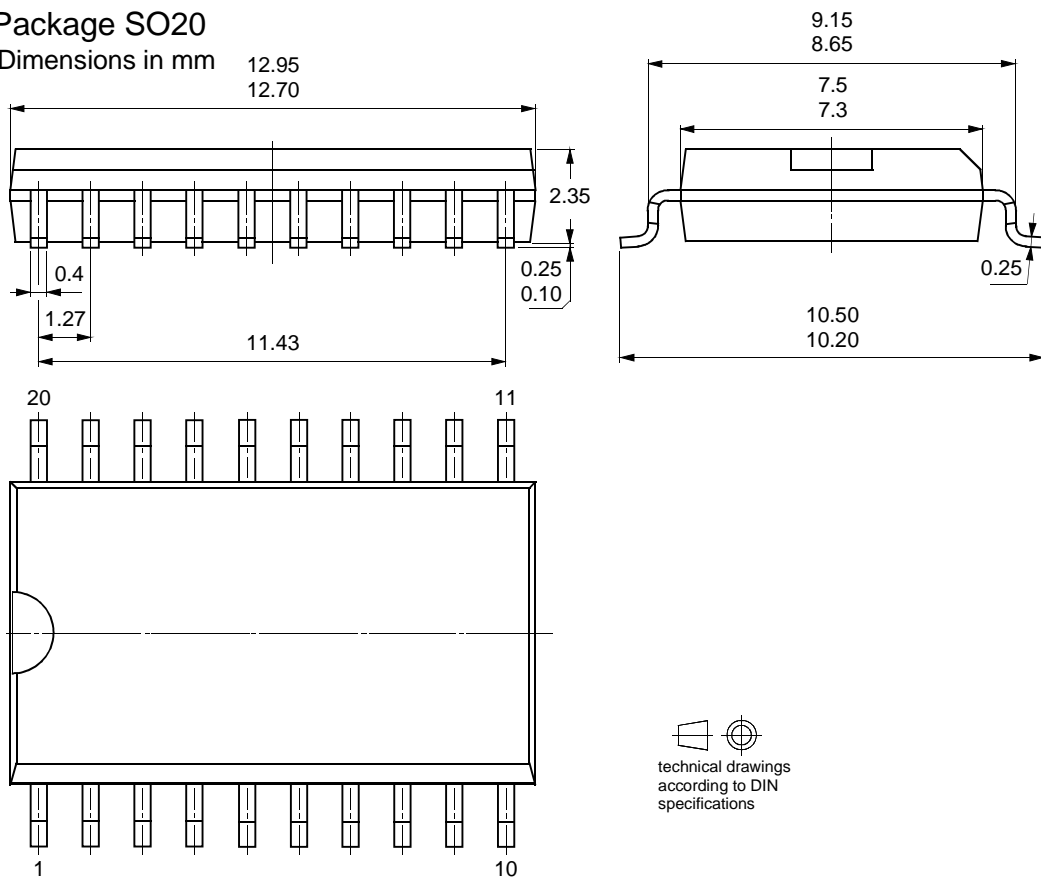

technical drawings

 according to DIN

 specifications



Atmel Headquarters

Corporate Headquarters
2325 Orchard Parkway
San Jose, CA 95131
TEL 1(408) 441-0311
FAX 1(408) 487-2600

Europe

Atmel Sarl
Route des Arsenaux 41
Case Postale 80
CH-1705 Fribourg
Switzerland
TEL (41) 26-426-5555
FAX (41) 26-426-5500

Asia

Room 1219
Chinachem Golden Plaza
77 Mody Road Tsimhatsui
East Kowloon
Hong Kong
TEL (852) 2721-9778
FAX (852) 2722-1369

Japan

9F, Tonetsu Shinkawa Bldg.
1-24-8 Shinkawa
Chuo-ku, Tokyo 104-0033
Japan
TEL (81) 3-3523-3551
FAX (81) 3-3523-7581

Atmel Operations

Memory

2325 Orchard Parkway
San Jose, CA 95131
TEL 1(408) 441-0311
FAX 1(408) 436-4314

Microcontrollers

2325 Orchard Parkway
San Jose, CA 95131
TEL 1(408) 441-0311
FAX 1(408) 436-4314

La Chantrerie
BP 70602
44306 Nantes Cedex 3, France
TEL (33) 2-40-18-18-18
FAX (33) 2-40-18-19-60

ASIC/ASSP/Smart Cards

Zone Industrielle
13106 Rousset Cedex, France
TEL (33) 4-42-53-60-00
FAX (33) 4-42-53-60-01

1150 East Cheyenne Mtn. Blvd.
Colorado Springs, CO 80906
TEL 1(719) 576-3300
FAX 1(719) 540-1759

Scottish Enterprise Technology Park
Maxwell Building
East Kilbride G75 0QR, Scotland
TEL (44) 1355-803-000
FAX (44) 1355-242-743

RF/Automotive

Theresienstrasse 2
Postfach 3535
74025 Heilbronn, Germany
TEL (49) 71-31-67-0
FAX (49) 71-31-67-2340

1150 East Cheyenne Mtn. Blvd.
Colorado Springs, CO 80906
TEL 1(719) 576-3300
FAX 1(719) 540-1759

Biometrics/Imaging/Hi-Rel MPU/ High Speed Converters/RF Datacom

Avenue de Rochepleine
BP 123
38521 Saint-Egreve Cedex, France
TEL (33) 4-76-58-30-00
FAX (33) 4-76-58-34-80

e-mail

literature@atmel.com

Web Site

<http://www.atmel.com>

© Atmel Corporation 2002.

Atmel Corporation makes no warranty for the use of its products, other than those expressly contained in the Company's standard warranty which is detailed in Atmel's Terms and Conditions located on the Company's web site. The Company assumes no responsibility for any errors which may appear in this document, reserves the right to change devices or specifications detailed herein at any time without notice, and does not make any commitment to update the information contained herein. No licenses to patents or other intellectual property of Atmel are granted by the Company in connection with the sale of Atmel products, expressly or by implication. Atmel's products are not authorized for use as critical components in life support devices or systems.

Atmel® is the registered trademark of Atmel.

Other terms and product names may be the trademarks of others.



Printed on recycled paper.