

September 1996

### DESCRIPTION

The TSC 75T980 Call Progress Tone Detector circuit allows automatic equipment to monitor tones in dial telephone systems that relate to the routing of calls. Such tones commonly include dial tones, circuits-busy tones, station-busy tones, audible ringing tones and others. By sensing signals in the range of 315 to 640 Hz, the TSC 75T980 does not require the use of precision tones to function. This means that tones which vary with location or call destination can be detected regardless of their exact frequency.

The low power CMOS switched capacitor filters used in the TSC 75T980 derive their accuracy from a 3.58 MHz clock, which in turn may be derived from other devices in the system being designed. The TSC 75T980 is available in a plastic 8-pin DIP and 16-pin SO packages.

### FEATURES

- Detects tones throughout the telephone progress supervision band (315 to 640 Hz)
- Sensitivity to -38 dBm
- Dynamic range over 36 dB
- 40 ms minimum detect (50 ms to output)
- Single supply CMOS (low power)
- Supply range 4.5 to 5.5 VDC
- Uses 3.58 MHz crystal or external clock
- 8-pin DIP and 16-pin SO packages
- Second source of Teltone M-980

### BLOCK DIAGRAM

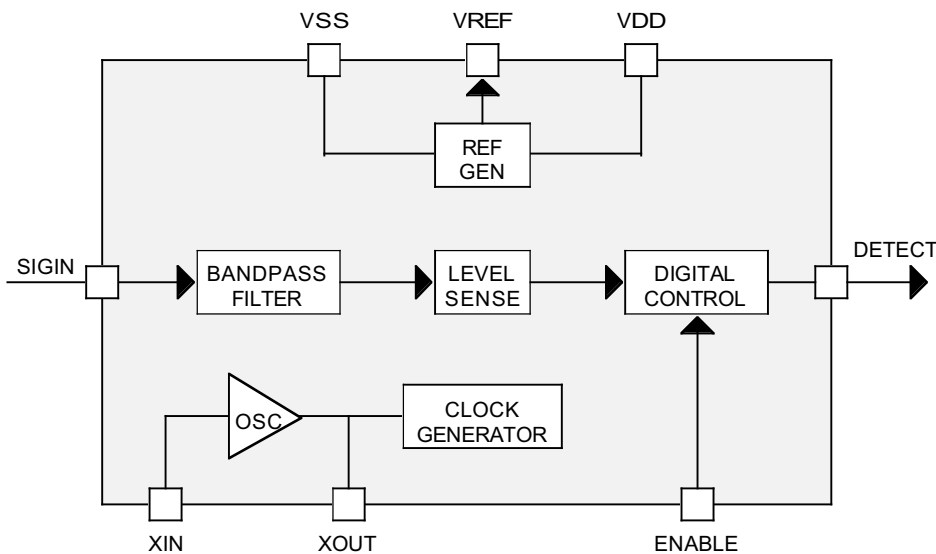

### PIN DIAGRAM

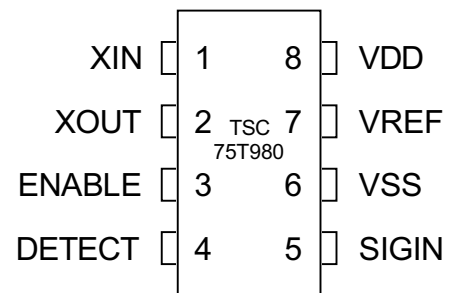

8-Pin DIP

CAUTION: Use handling procedures necessary for a static sensitive component.

# TSC 75T980

## Call Progress

## Tone Detector

### PIN DESCRIPTION

NAME	TYPE	DESCRIPTION
SIGIN	I	Accepts analog input signal. See "Electrical Characteristics" for voltage levels, and "Timing Characteristics" for timing.
DETECT	O	Call progress detect output. Goes to logic "1" when signal in 315-640 Hz band is sensed. See "Timing Characteristics."
ENABLE	I	Application of logic "1" on this pin enables the output; logic "0" disables output.
V <sub>REF</sub>	O	Supplies voltage at half V <sub>DD</sub> for voltage reference of on-chip op amps.
XIN, XOUT	I	Crystal connections to on-chip oscillator circuit.
V <sub>DD</sub>	-	Positive power supply connection
V <sub>SS</sub>	-	Negative power supply connection

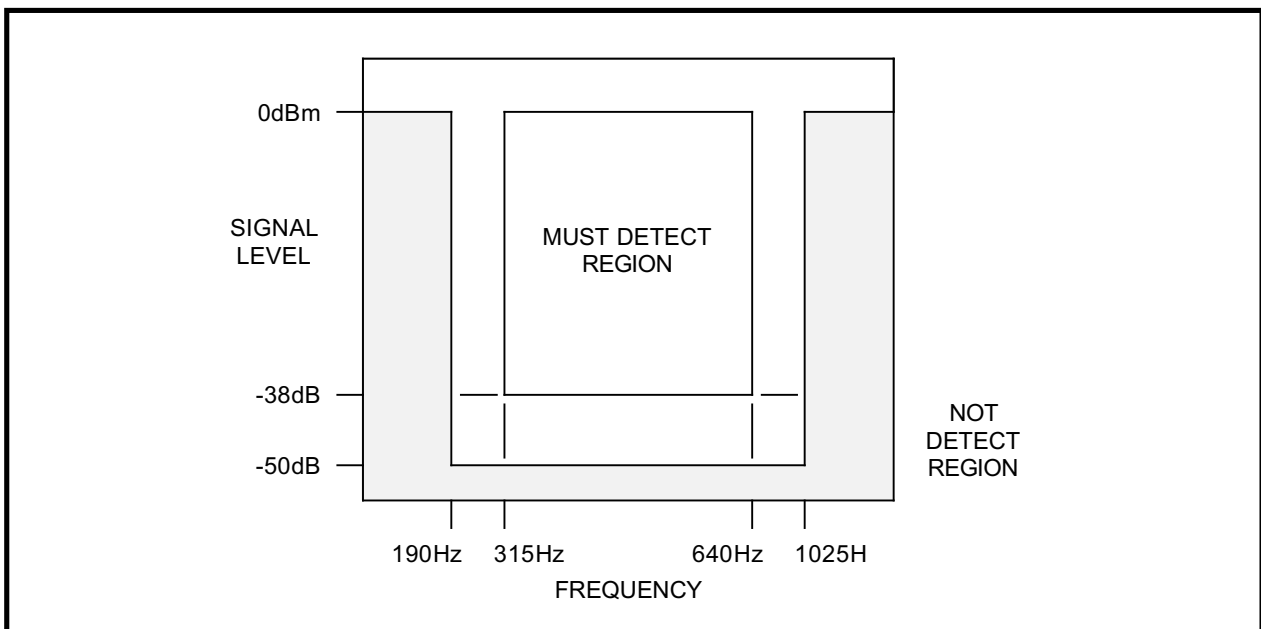

**FIGURE 1: Detect and Reject Regions**

# TSC 75T980

## Call Progress Tone Detector

### ELECTRICAL SPECIFICATIONS

#### ABSOLUTE MAXIMUM RATINGS

(Operation above absolute maximum ratings may permanently damage the device.)

PARAMETER		RATING
DC Supply Voltage	$V_{DD}-V_{SS}$	16V
Input Voltage	All inputs except SIGNAL IN	$(V_{DD} + 0.5V)$ to $(V_{SS} - 0.5V)$
SIGNAL IN Voltage		$(V_{DD} + 0.5V)$ to $(V_{SS} - 22V)$
Storage Temperature		-65°C to 150°C
Operating Temperature		-30°C to 70°C
Lead Temperature	Soldering, 5 sec.	260°C

#### ELECTRICAL CHARACTERISTICS

( $T_A = 25^\circ\text{C}$ ,  $V_{DD} - V_{SS} = 4.5\text{V}$  to  $5.5\text{V}$ , dBm is referenced to  $600\Omega$ )

PARAMETER	CONDITIONS	MIN	NOM	MAX	UNITS
Supply Current	$V_{DD} - V_{SS} = 5\text{V}$	-	4	10	mA
Signal level for detection	315-640 Hz	-38	-	0	dBm
Signal level for rejection	315-640 Hz	-	-	-50	dBm
	$f > 1025\text{ Hz}$ , $f < 190\text{ Hz}$	-	-	0	dBm
DETECT output ( $I_{out} = +1\text{mA}$ )	Logic 0	-	-	0.5	V
	Logic 1	4.5	-	-	V
ENABLE, XIN input ( $I_{in} = 10\mu\text{A}$ )	Logic 0	$V_{SS}$	-	$V_{SS} + 0.2$	V
	Logic 1	$V_{DD} - 0.2$	-	$V_{DD}$	V
XIN duty cycle		40	-	60	%
XIN, XOUT loading		-	-	10	pF
VREF output	Deviation	-2	$(V_{DD} + V_{SS})/2$	+2	%
	Resistance	3.25	-	6.75	k $\Omega$
SIGIN input	Maximum voltage	$V_{DD} - 10$	-	$V_{DD}$	V
	Impedance (500 Hz)	80	-	-	k $\Omega$

# TSC 75T980

## Call Progress

### Tone Detector

#### ELECTRICAL SPECIFICATIONS (continued)

#### TIMING CHARACTERISTICS

(TA = 25°C, V<sub>DD</sub> – V<sub>SS</sub> = 4.5V TO 5.5V)

PARAMETER	CONDITIONS	MIN	NOM	MAX	UNITS
t <sub>MD</sub> Signal duration for detection	315-640 Hz	40		-	ms
Interval duration for detection	Signal dropping from				
	-38 dBm to -50 dBm (t <sub>2</sub> )	-		40	ms
	Signal dropping from				
	0 dBm to -50 dBm (t <sub>1</sub> )	-		90	ms
t <sub>B</sub> Tone dropout bridging		-		20	ms

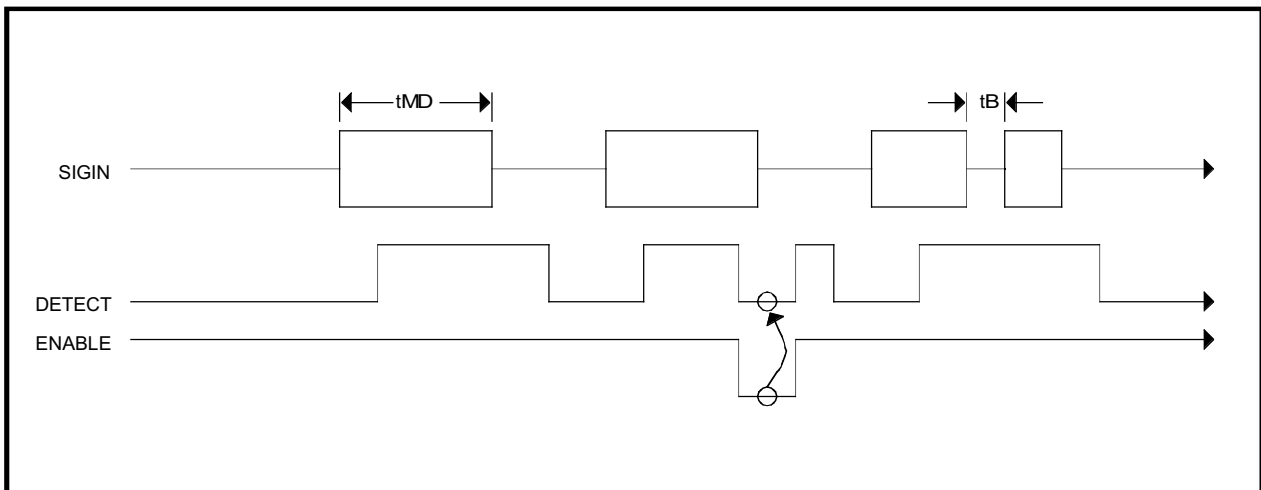

FIGURE 2: Basic Timing

# TSC 75T980 Call Progress Tone Detector

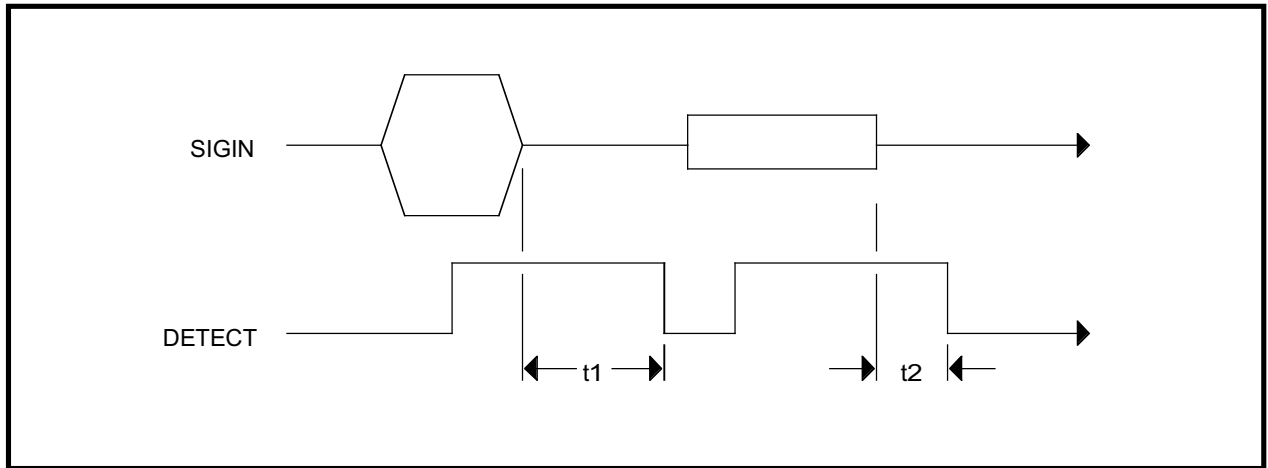

FIGURE 3: Effect of Amplitude on Timing

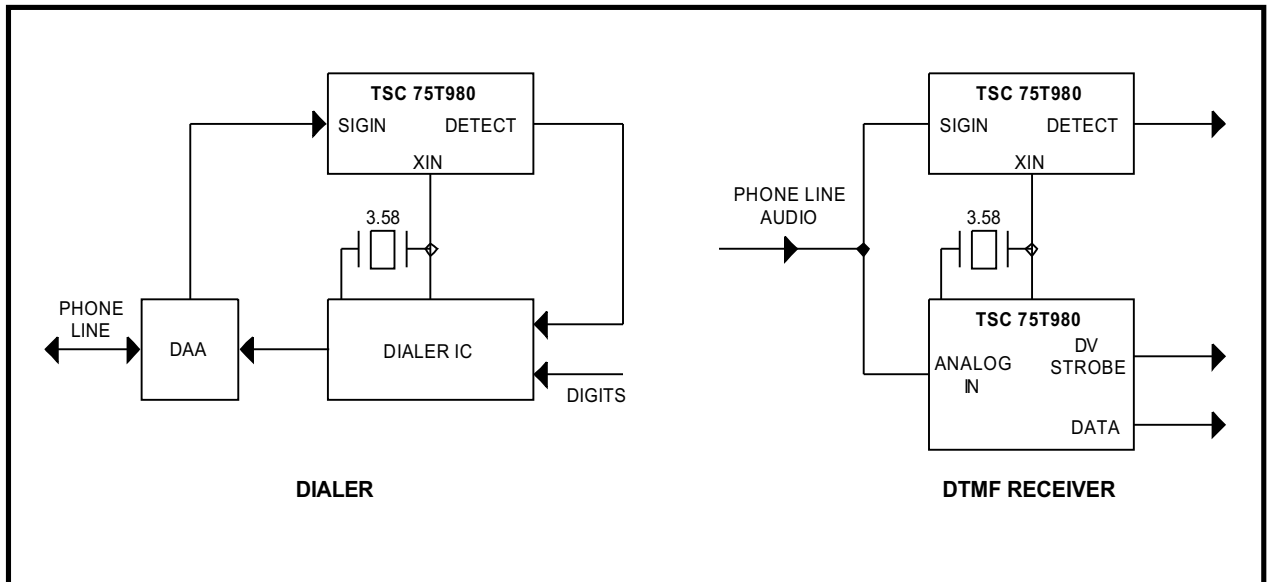

FIGURE 4: Applications Circuits

# TSC 75T980

## Call Progress

## Tone Detector

### PACKAGE PIN DESIGNATIONS

(Top View)

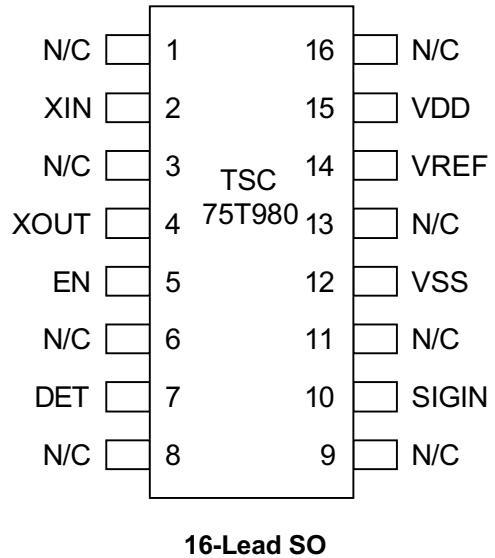
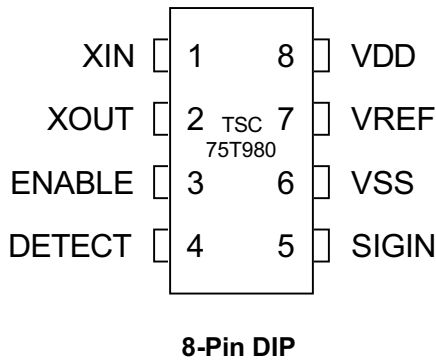

CAUTION: Use handling procedures necessary for a static sensitive component.

### ORDERING INFORMATION

PART DESCRIPTION	ORDER NO.	PKG. MARK
TSC 75T980 8-pin Plastic DIP	75T980-CP	75T980-CP
TSC 75T980 16-pin SO Package	75T980-CL	75T980C

No responsibility is assumed by TDK Semiconductor Corporation for use of this product nor for any infringements of patents and trademarks or other rights of third parties resulting from its use. No license is granted under any patents, patent rights or trademarks of TDK Semiconductor Corporation. TDK Semiconductor Corporation reserves the right to make changes in specifications at any time without notice. Accordingly, the reader is cautioned to verify that the data sheet is current before placing orders

TDK Semiconductor Corporation, 14351 Myford Road, Tustin, CA 92780-7068 (714) 573-6000, FAX: (714) 573-6914