



TR9C1710 GRAPHICS COLOR PALETTE

PRODUCT INFORMATION

DISTINCTIVE CHARACTERISTICS

- o Combination Look-up Table and Triple Video DAC
- o Directly drives single- and double-terminated 75-ohm transmission lines
- o Displays 256 colors from a palette of 256K colors
- o Asynchronous Microprocessor interface
- o Read and Write contents of Look-up Table
- o VGA, Super-VGA, VESA, TIGA™, and 8514/A compatible with enhanced features
- o Unlimited access to Look-up Table; no need to wait for retrace
- o Unlimited access to Mask Register
- o 28-pin PDIP and 32- and 44-pin PLDCC Packages
- o Available in 110-, 80-, 66-, and 50-MHz Pixel Rates
- o High-Performance CMOS for low operating power
- o TTL-compatible inputs

GENERAL DESCRIPTION

The TR9C1710 is a monolithic 256-word by 18-bit Look-up Table and Triple Video DAC, with 6-bit DACs. The Look-up Table accepts up to eight bits per pixel from the Frame Buffer and performs a translation into three 6-bit values for conversion into Red, Green, and Blue analog signals. Each of the Video DACs can directly drive a double-terminated 75-ohm transmission line.

The TR9C1710 incorporates a proprietary feature called Pixel Replicate™ that allows both Read and

Write operations to occur to the Look-up Table when the display is active without causing random noise on the screen.

The TR9C1710 is available in standard 28-pin DIP and 32- and 44-pin PLDCC packages and supports screen resolutions up to 1280 by 1024 pixels with the color capacity necessary for high-performance Personal Desktop Computers and Workstation Graphics systems. The TR9C1710 is fully compatible with VGA and Super-VGA industry standards.

BLOCK DIAGRAM

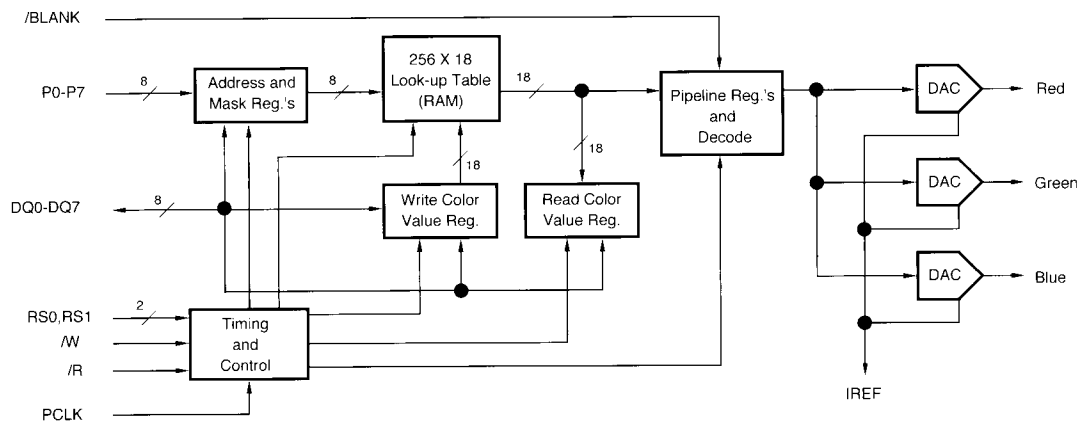

MU9C1710

PINOUT DIAGRAMS

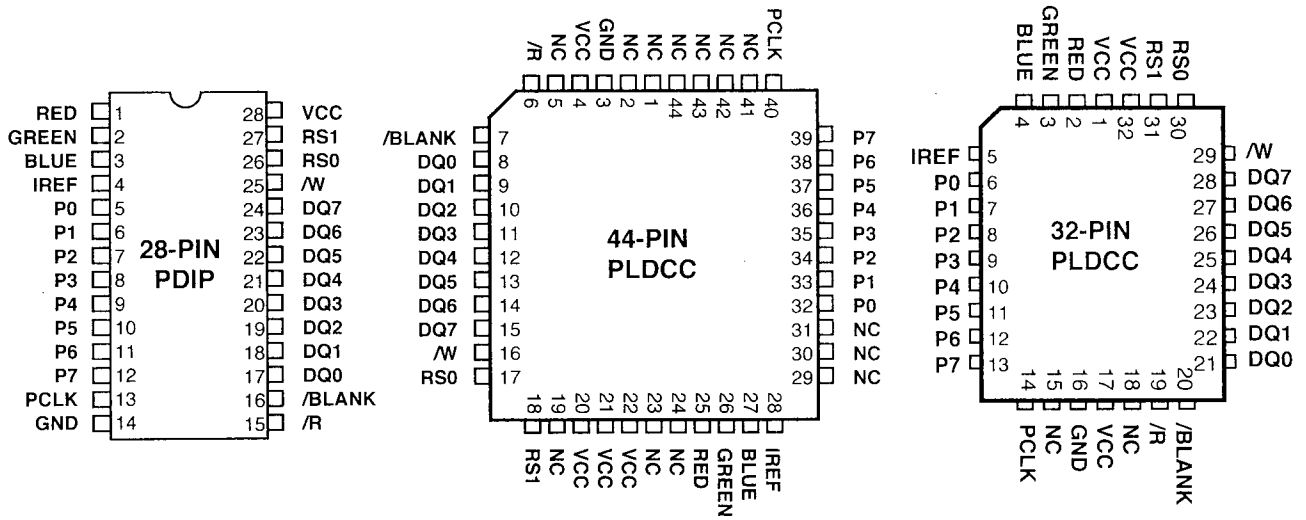

ORDERING INFORMATION

Part Number	Speed	Package	Temperature Range
TR9C1710-XXYC			0 to 70°
XX = 50	50 MHz		
XX = 66	66 MHz		
XX = 80	80 MHz		
XX = 11	110 MHz		
Y = P		28-pin, Plastic DIP	
Y = D		44-pin, PLDCC	
Y = E		32-pin, PLDCC	

MUSIC™ Semiconductors

U.S.A. Headquarters

MUSIC Semiconductors, Inc.
1150 Academy Park Loop
Suite 202
Colorado Springs, CO 80910

Telephone: (719) 570-1550
Within U.S.: (800) 933-1550
FAX: (719) 570-1555

European Headquarters

MUSIC Semiconductors BV
PO Box 184
NL-6470 ED Eygelshoven
The Netherlands

Telephone: +31 45 467878
Europe FAX: +31 45 467822
Far East and Corporate FAX:
+31 45 353675

U.S. Western Area Sales

MUSIC Semiconductors, Inc.
1136 E. Hamilton Avenue
Suite 203
Campbell, CA 95008

Telephone: (408) 371-3993
FAX: (408) 371-0878

U.S. Eastern Area Sales

MUSIC Semiconductors, Inc.
P.O. Box 415
234 West Mill Road
Long Valley, NJ 07853

Telephone: (908) 876-9691
FAX: (908) 876-9542

MUSIC Semiconductors agent or distributor:

MUSIC Semiconductors reserves the right to make changes to its products and specifications at any time in order to improve on performance, manufacturability, or reliability. Information furnished by MUSIC is believed to be accurate, but no responsibility is assumed by MUSIC Semiconductors for the use of said information, nor for any infringements of patents or of other third-party rights which may result from said use. No license is granted by implication or otherwise under any patent or patent rights of any MUSIC company.

© Copyright 1992, MUSIC Semiconductors NV