

Company Profile

Established:	September 11th 1978
Capital :	USD 32 million
Revenue :	USD 59 million
Employees :	900
Listing :	August 29 th 1998, Taiwan Stock Exchange
Stock Code :	2375
Product Lines :	Aluminum Electrolytic Capacitor Conductive Polymer Solid Aluminum Capacitor

Milestones:	1956	Set-up Aluminum Capacitor Division at SAMPO Electronic
	1975	First development and mass production at Low ESR product in Taiwan
	1978	Foundation of Teapo Electronic Capacitor
	1998	Company stock listed in OTC market in Taiwan
	1998	Manufacturing plant in Dongguan ,China
	2001	Dongguan factory certified by ISO9001:2000
	2005	Merge G-LUXON Electronic Corporation
	2006	Manufacturing polymer capacitors
	2008	Dongguan factory certified by ISO9001:2008
	2010	Dongguan factory certified by ISO14001:2004
	2014	Dongguan factory certified by ISO/TS16949:2009
	2014	Dongguan factory certified by IECQ/QC080000:2012

1

CONDUCTIVE POLYMER ALUMINUM SOLID CAPACITORS-----25

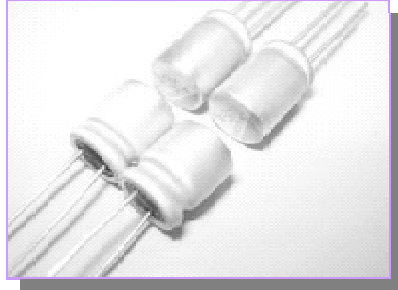

2

SURFACE MOUNT ALUMINUM ELECTROLYTIC CAPACITORS----53



3

MINIATURE ALUMINUM ELECTROLYTIC CAPACITORS-----79

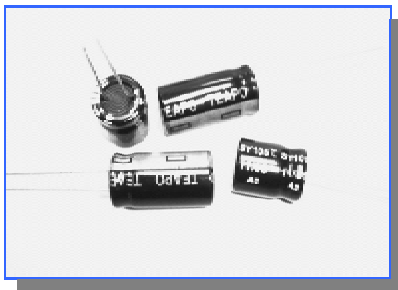

4

LARGE ALUMINUM ELECTROLYTIC CAPACITORS-----144

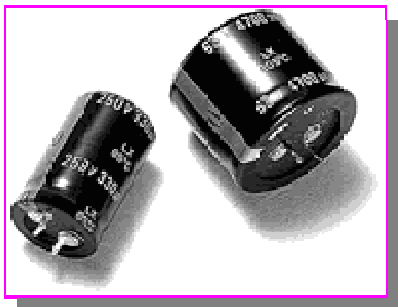

Systematic Diagram of Teapo Capacitor

Conductive Polymer Aluminum Solid Capacitors :Dip

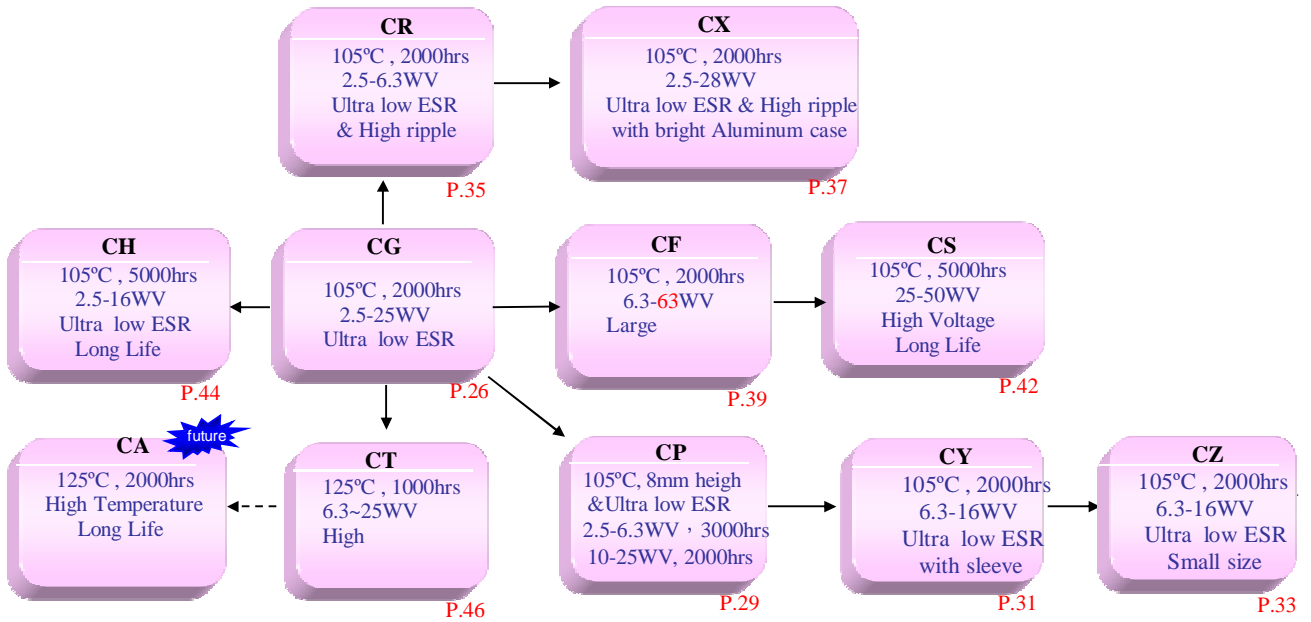

Conductive Polymer Aluminum Solid Capacitors :SMD

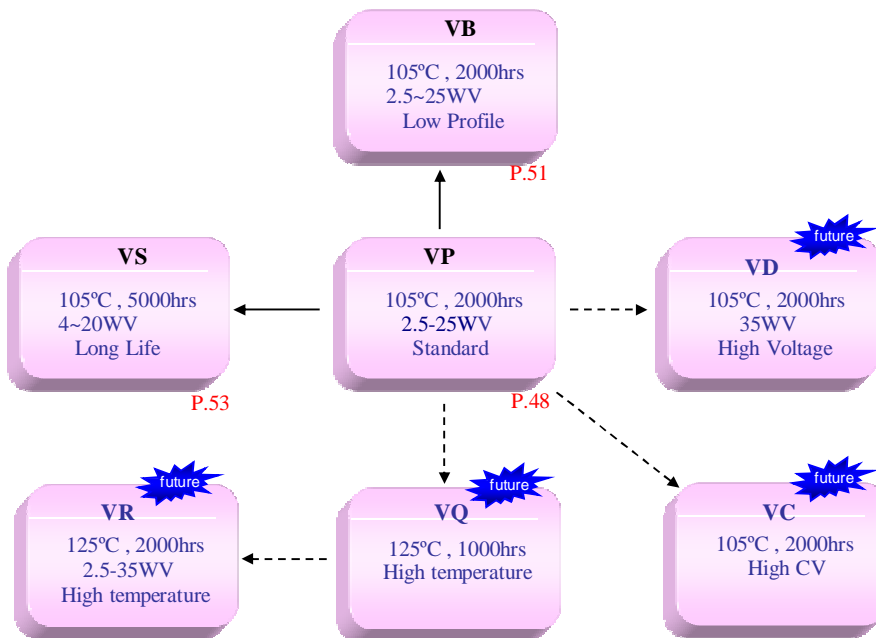

Systematic Diagram of Teapo Capacitor

Chip Types :

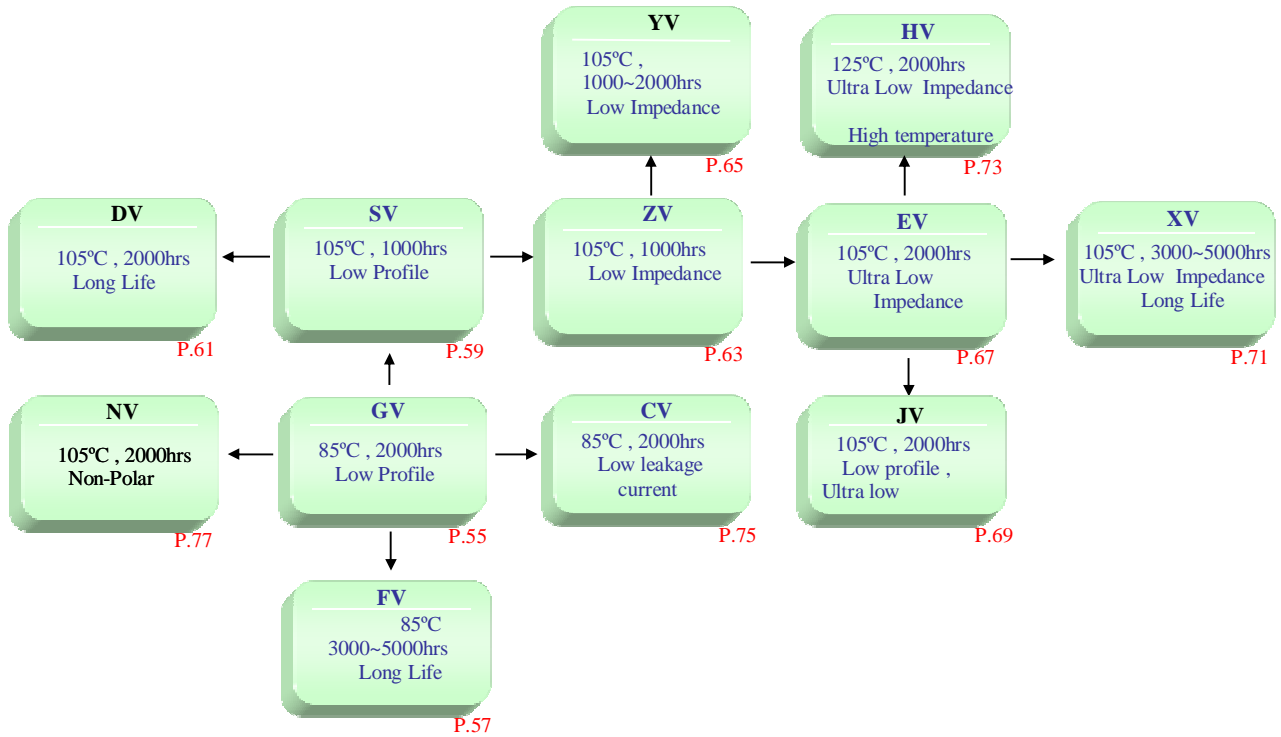

Miniature Radial Lead

(General Purpose) :

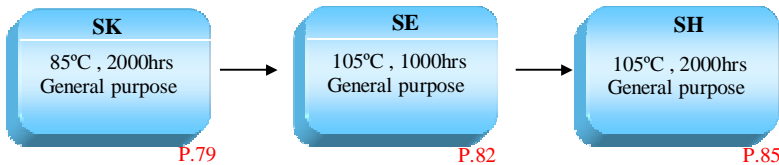

(Low Profile) :

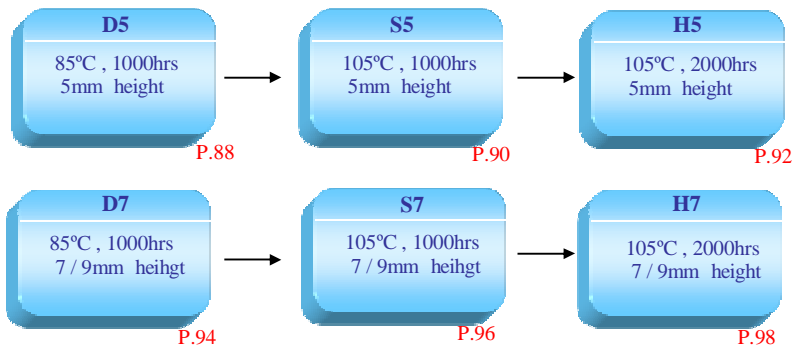

(Low Leakage Current) :

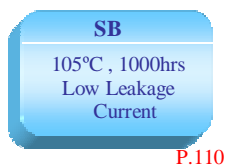

(High Temperature) :

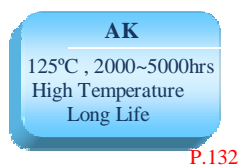

(LED Lighting) :



Systematic Diagram of Teapo Capacitor

Miniature Radial Lead Types :

(Bi / Non-polar) :

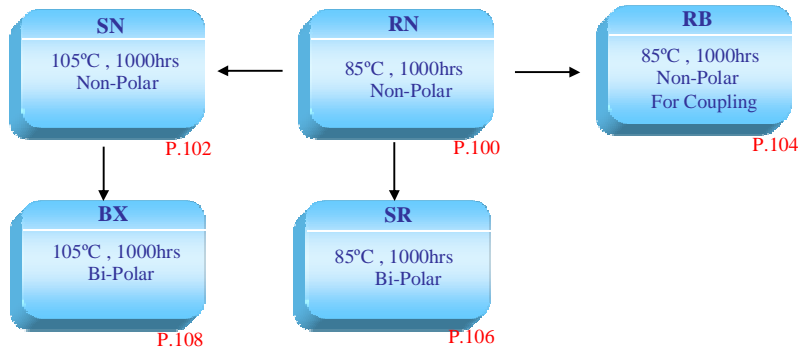

(Low Impedance) :

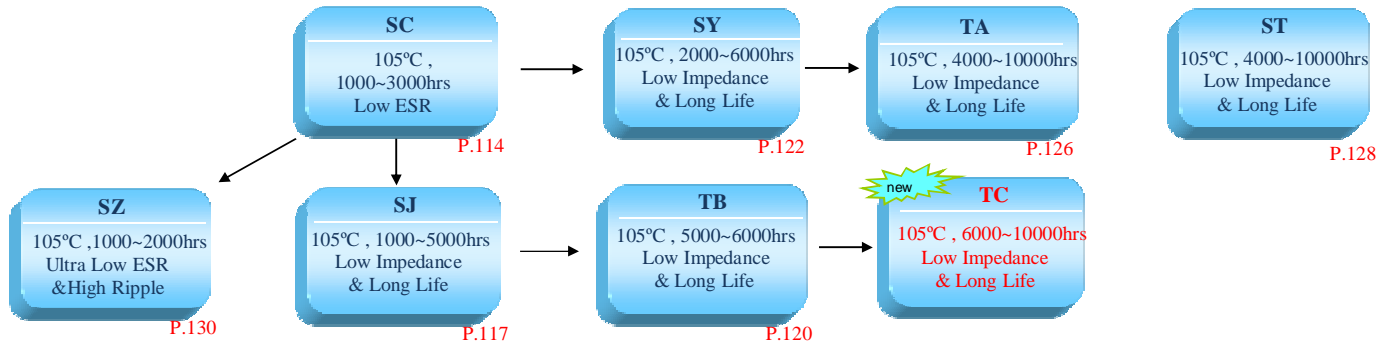

(High Ripple) :

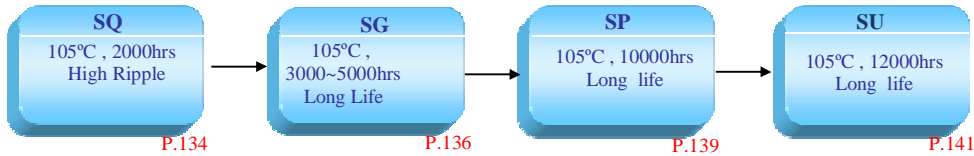

(Slim Types) :

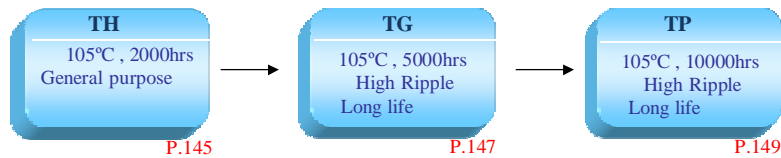

Large Can Types :

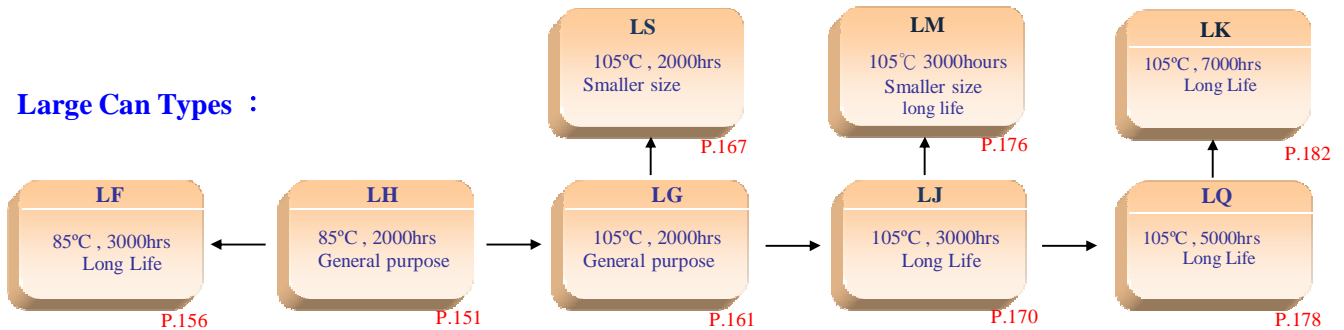

ALUMINUM ELECTROLYTIC CAPACITORS

Recommended Applications	Conductive Polymer	Chip Type	Miniature Aluminum 6.3~100V	Miniature Aluminum 160~500V	Large Can Type
Automotives	CT	HV	AK,ST	SP	LQ
Battery Charge	CF,CR,CG	Whole Series	Whole Series	Whole Series	--
Display	CG	Whole Series	Whole Series	Whole Series	Whole Series
Digital Still Camera	VP,CG	--	--	--	--
Home Appliance	CG	Whole Series	Whole Series	Whole Series	Whole Series
Lighting	CG,CF	XV,HV	SJ,SY,ST,AK	SQ,SG,SP	--
MB	CR,CG,CX	Whole Series	Whole Series	Whole Series	--
NB	VP	--	--	--	--
Networks	CG,CF	XV,HV	SJ,SY,ST	SG,SP	--
Power	CG,CF,CR,CT	Whole Series	Whole Series	Whole Series	Whole Series
TFT frame	--	SV,DV	SH,SC	SH	--
Gaming	VP	GV,SV	SK,SH	SK,SH	LH,LG
Audio(stereo)	--	--	Whole Series	Whole Series	Whole Series
Vedio (DVD)	VP,CG	--	S5,S7,SK,SH,SC,SY	SK,SH	--
Toys	VP	--	SK	SK	LH

1 Conductive Polymer Aluminum Solid Electrolytic Capacitors

Series		Features	Endurance (+R=With ripple)	Voltage Range (VDC)	Capacitance Range (uF)	Page
TEAPO	LUXON					
CG	CG	Ultra Low ESR	105°C 2000hours	2.5 ~25V	10 ~ 2200	26
CP	CP	8 mm height & Ultra Low ESR	105°C 3000hours	2.5 ~25V	10 ~ 1200	29
CY	CY	Ultra Low ESR with sleeve	105°C 2000hours	6.3 ~16V	150 ~ 1800	31
CZ	CZ	Ultra Low ESR with Small size	105°C 2000hours	2.5 ~16V	100 ~ 2200	33
CR	CR	Ultra Low ESR & Higher Ripple Current	105°C 2000hours	2.5 ~6.3V	270 ~ 2700	35
CX	CX	Ultra Low ESR & Higher Ripple Current with bright Aluminum case	105°C 2000hours	2.5 ~28V	33~ 820	37
CF	CF	Super Low ESR & Large Capacitance	105°C 2000hours	2.5 ~63V	10~ 2000	39
CS	CS	High Voltage & Long Life	105°C 2000/5000hours	25~50V	39~470	42
CH	CH	Ultra Low ESR & Long Life	105°C 5000hours	2.5 ~16V	100 ~ 2200	44
CT	CT	High Temperature	125°C 1000hours	6.3 ~25V	10 ~ 1200	46
VP	VP	SMD Standard	105°C 2000hours	2.5-25V	22 ~ 1500	48
VB	VB	SMD Low Profile	105°C 2000hours	2.5~25V	33~1200	51
VS	VS	SMD Long life and Ultra low ESR	105°C 5000hours	4~20V	22~470	53

ALUMINUM ELECTROLYTIC CAPACITORS

2 Surface Mount Aluminum Electrolytic Capacitors

Series			Features	Endurance (+R=With ripple)	General	Low leakage	Low Profile	Low Impedance	Long Life	Voltage Range (VDC)	Capacitance Range (uF)	Page
TYPE	TEAPO	LUXON										
Vertical Chip	GV	GV	Low profile V-Chip	85°C 2000hours	*		*			4~100	1~1500	55
	FV	FV	Long life V-Chip	85°C 3000~5000hours					*	4~100	1~1000	57
	SV	SV	Low profile V-Chip	105°C 1000hours	*		*			4~100	1~1500	59
	DV	DV	Long life V-Chip	105°C 2000hours					*	6.3~450	1~2200	61
	ZV	ZV	Low impedance V-Chip	105°C 1000hours+R				*		4~50	1~1500	63
	YV	YV	Low impedance V-Chip	105°C 1000~2000hours+R				*		6.3~50	1~1500	65
	EV	EV	Ultra Low impedance V-Chip	105°C 2000hours+R				*		6.3~50	4.7~1500	67
	JV	JV	Low profile vertical chip	105°C 2000hours+R				*		6.3~35	10~1800	69
	XV	XV	Ultra Low impedance V-Chip	105°C 3000~5000 hours+R				*	*	6.3~50	1~1000	71
	HV	HV	Higher temperature range V-Chip	125°C 2000hours				*		6.3~50	47~1000	73
	CV	CV	Low leakage current V-Chip	85°C 2000hours		*				6.3~50	1~100	75
	NV	NV	Non-polarized V-Chip	105°C 2000 hours		*				6.3~35	1~47	77

3 Miniature Aluminum Electrolytic Capacitors

Series			Features	Endurance (+R=With ripple)	General	Miniature	Long Life	Low impedance	Voltage Range (VDC)	Capacitance Range (uF)	Page
TYPE	TEAPO	LUXON									
General Type	SK	GR	General purpose	85°C 2000hours	*				6.3~500	1~22000	79
	SE (SEK)	SE	General purpose	105°C 1000hours	*				6.3~450	1~15000	82
	SH	SM	Miniature General purpose	105°C 2000hours	*				6.3~500	1~22000	85
Low Profile	D5	SF	5 mm height	85°C 1000hours		*			4~50	1~220	88
	S5	FX	5 mm height	105°C 1000hours		*			4~50	1~470	90
	H5	H5	5 mm height	105°C 2000hours		*	*		4~50	1~330	92
	D7	SS	7 & 9 mm height	85°C 1000hours		*			4~63	1~470	94
	S7	SX	7 & 9 mm height	105°C 1000hours		*			4~63	1~470	96
	H7	H7	7 & 9 mm height	105°C 2000hours		*	*		4~63	1~470	98

ALUMINUM ELECTROLYTIC CAPACITORS

Series			Features	Endurance (+R=With ripple)	General	Miniature	Long Life	Low Impedance	High Ripple	Voltage Range (VDC)	Capacitance Range (uF)	Page
TYPE	TEAPO	LUXON										
Bi/Non - polar	RN	RN	Non-polar	85°C 1000hours	*	*				4~250	1~6800	100
	SN	RX	Non-polar	105°C 1000hours	*	*				6.3~250	1~2200	102
	RB	RB	Non-polar for crossover	85°C 1000hours	*					25~100	1~100	104
	SR	BP	Bi-polar, Horizontal correction	85°C 1000hours	*					25~50	2.2~47	106
	BX	BX	Bi-polar, Horizontal correction	105°C 1000hours	*					25~50	1~33	108
	SB	LX	Low leakage current	105°C 1000hours	*					6.3~100	1~15000	110
Low Impedance	SC	LZ	Low ESR and high frequency	105°C 1000~3000hours+R				*		6.3~100	4.7~15000	114
	SJ	LU	Low impedance and high ripple	105°C 1000~5000hours+R			*	*		6.3~100	5.6~6800	117
	TB	TB	Low impedance and high ripple	105°C 5000~6000hours+R			*	*		6.3~35	27~8200	120
	SY	LT	Low impedance and long life	105°C 2000~6000hours+R			*	*		6.3~100	2.2~15000	122
	TA	TA	Low impedance and long life	105°C 4000~10000hours+R			*	*		6.3~35	33~8200	126
	ST	ST	Low impedance and long life	105°C 4000~10000hours+R			*	*		6.3~100	2.2~15000	128
	TC	TC	Low impedance and long life NEW	105°C 6000~10000hours+R		*	*	*		6.3~100	8.2~8200	130
	SZ	LW	Ultra low ESR	105°C 1000~2000hours+R				*		6.3~16	470~3300	134
High Temperature	AK	AK	High Temperature and Long Life	125°C 2000-5000hours			*	*		10~450	1-4700	136
High Ripple	SQ	LB	High ripple and high voltage	105°C 2000hours+R				*		160~450	2.2~220	138
	SG	LC	High ripple and long life	105°C 3000~5000hours+R			*	*		160~500	3.3~330	140
	SP	SP	High ripple and long life	105°C 8000~10000hours+R			*	*		160~450	3.3~330	143
	SU	SU	High ripple and long life	105°C 10000~12000hours+R			*	*		160~450	3.3~330	145
LED Lighting	TE	TE	LED Lighting and Ultra Long Life	105°C 12000~20000Hrs+R		*	*			160~400	1.0~33	147
Slim capacitors	TH	TH	General purpose	105°C 2000hours	*					250~450	10~150	149
	TG	TG	High ripple and long life	105°C 3000~5000hours+R			*	*		250~450	10~150	151
	TP	TP	High ripple and long life	105°C 8000~10000hours+R			*	*		160~450	10~330	153

4 Large Can Type Aluminum Electrolytic Capacitors

Series			Features	Endurance (+R=With ripple)	General	Miniature	Long Life	Sohent Roof	Voltage Range (VDC)	Capacitance Range (uF)	Page
TYPE	TEAPO	LUXON									
Snap-in	LH	TW	General purpose	85°C 2000hours+R	*				6.3~500	56~120000	155
	LF	LF	Long life	85°C 3000hours+R			*		10~450	56~56000	160
	LG	HW	General purpose	105°C 2000hours+R	*				6.3~500	47~82000	165
	LS	LS	Smaller size	105°C 2000hours+R	*				160~450	100~3300	171
	LJ	LJ	Long life	105°C 3000hours+R			*		10~500	270~68000	174
	LM	LM	Smaller size and long life	105°C 3000hours+R	*		*		400~450	82~1000	180
	LQ	LQ	Long life	105°C 5000hours+R			*		160~500	270~2200	182
	LK	LK	Long life	105°C 7000hours+R			*		160~450	220~2200	186

ALUMINUM ELECTROLYTIC CAPACITORS

1-1 Precautions in Using Aluminum Electrolytic Capacitors

Please note the following recommendations when using capacitors:

1. Electrolytic capacitors for DC applications require polarization .
Confirm the polarity before use . The circuit life may be shortened or the capacitor may be damaged if insert in reversed polarity . For use on circuits whose polarity is occasionally reversed , or whose polarity is unknown , use non-polar capacitors . Also note that the electrolytic capacitors cannot be used for AC applications .
2. Do not apply a voltage exceeding the capacitor's voltage rating .
If a voltage exceeding the capacitor's voltage rating is applied , the capacitor may be damaged by increased leakage current . When using the capacitor with AC voltage do not exceed the rated voltage .
3. Do not allow excessive ripple current passing.
Use the electrolytic capacitor at current value within the permissible ripple range . If the ripple exceeds the specified value , request capacitors for high ripple current applications .
4. Ascertain the operation temperature range .
Use the electrolytic capacitors according to the specified operation temperature range . Use at room temperature will ensure a longer life .
5. The electrolytic capacitor is not suitable for circuits which are charged and discharged repeatedly .
If used in circuits which are charged and discharged repeatedly , the capacitance value may drop or the capacitor may be damaged . Please consult our engineering department for assistance in these applications .
6. When capacitors have been left unused for long time , use them only after due voltage treatments . Long storage of capacitors tends to rise their leakage current levels . In such cases , be sure to provide the necessary voltage treatment before use .
7. Be careful of temperature and time when soldering .
When soldering a printed circuit board with various components , care must be taken that the soldering temperature is not too high and that the dipping time is not too long .
Otherwise , there will be adverse effect on the electrical characteristics and insulation sleeve of electrolytic capacitors . In the case of small-size electrolytic capacitors , nothing abnormal will be occurred if dipping is performed at less than 260°C for less than 10 seconds .

8. Cleaning circuit boards after soldering .
Halogenated hydrocarbon cleaning solvents are not recommended for use in cleaning capacitors supplied with exposed end seals .
Where cleaning with a halogenated solvent is desired , capacitors should be ordered with an Epoxy-coated end seal .
9. Do not apply excessive force to the lead wires or terminals .
If excessive force is applied to the lead wires and terminals , they may be broken or their connections on the internal elements may be affected . (For strength of terminals , please refer to JIS C 5101-1:2010 and C 5101-4:2010 .)
10. Keep the following clearance between the vent of the capacitor and the case of the appliance . Do not block the operation of the vent , unless otherwise described on the catalogues or product specifications . The narrower clearance may adversely affect the vent operation and result in an explosion of the capacitor .

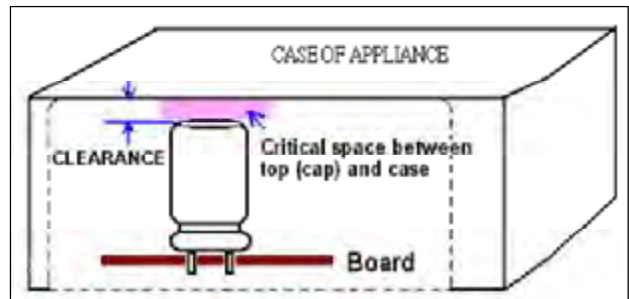

Case diameter	Clearance
ϕ 6.3 to ϕ 16 mm	2 mm minimum
ϕ 18 to ϕ 35 mm	3 mm minimum
ϕ 40 mm & up	5 mm minimum

Fig.1-1

Attention

- The description in this catalogue is subject to change without prior notice for product improvement . Therefore , please confirm the specification before ordering products .
- The general characteristics , reliability data , etc ., described in this catalogue should not be construed as guaranteed values , they are merely standard values .
- Before using the products , please read the notes in this catalogue carefully for proper use .

ALUMINUM ELECTROLYTIC CAPACITORS

1-2 Technical Concepts

1. The material and structure of Electrolytic Capacitors

Electrolytic Capacitor is a simple module . It simply contains an insulator between relative conductors in an electrode. The major internal raw material contains an element constructed by an separator paper wrap around the anode foil and cathode foil , which is then impregnated with the electrolyte , inserted into an aluminum case and sealed.

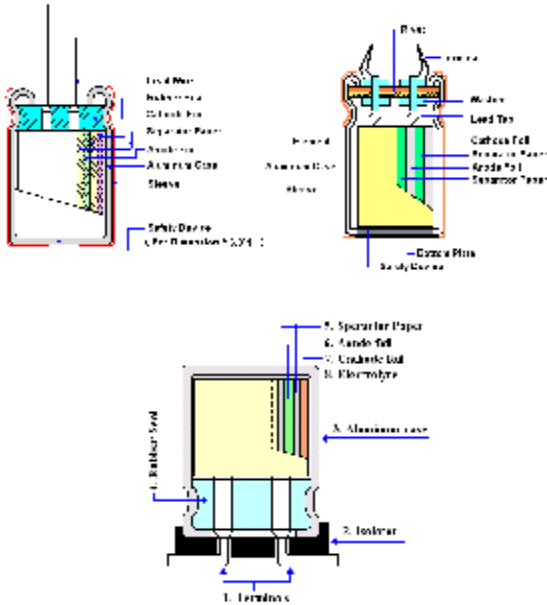

Fig. 1-2

2. Production Processes

1. Etching : The process to increase surface area of aluminum foil by using chemical erosion or chemical corrosion method is called Etching . Normally chemical corrosion method uses the ripple current of electrolyte , combination of the liquid and temperature to determine the size, shape , and quantity of the dense network of microscopic channels on the aluminum foil surface .
2. Forming : The production process of the anode aluminum foil of electrolytic capacitors is by anodic oxidation of the etched aluminum foil . The production of the cathode aluminum foil sometimes involves oxidation in special purposes . This anodic oxidation process is called Forming . Boric acid or organic acid is used for high voltage forming and phosphoric acid or ammonium adipate is used for low voltage forming in order to obtain stable natural oxide layer of Al_2O_3 .
3. Slitting : The cutting of the aluminum foil and separator paper according to the required length .
4. Winding : The stitching or cold welding of cut anode and cathode foils and tab terminal , and wrap the electrolytic paper in between the anode and cathode , then fix the end with glue or sticky tape , and attached leads is called the capacitor "element" .
5. Impregnation : The process of eliminating water from the elements by pressurizes or vacuum in order to soak the element with the electrolyte is called Impregnation . The elements fully filled with electrolyte is then centrifuged to remove excess electrolyte .
6. Assembly : The elements seal with rubber to stop the leakage of electrolyte then slip into a sleeve to form the final product .
7. Aging : The purpose of Aging is to repair the oxide film damage by recharging and electrolyte .

1-3 The Function of Electrolytic Capacitors

The electrolytic capacitors could be widely used in appliance (ie. TV , radio , audio equipment , washing machine and air conditioner.....etc .) , computer equipment (mother board, image device & the peripherals such as the printer , drawing device, scanner...etc) , communication equipment , estate equipment , measure instrument and also the industrial instrument , airplane , firebomb , satellite...etc. as a piloting equipment.

*According to the inflict electric wave & using purpose , it basically with some classified purposes as below :

1. DC Voltage :

- a. For Momentary High Voltage : For using to the impulse generator such as the shock wave resistance test of the heavy electric machine .
- b. For High Electric Current : For using to the welding machine , X- Ray facility , copy machine and discharge processing device .
- c. For DC High Voltage : The electrolytic capacitor and rectifier composing , a special DC high voltage been happened after charged , for using to the power of electronic microscope and accelerator .
- d. For Integration & Memory : For either memory circuit or compare circuit inside the calculator .

2. The DC voltage that with alternate ingredient :

- a. For Wave Filter : Combination with the chip resistor & inductor as a internet , to be past by DC current or some frequency to closure or decline some other frequency .
- b. For Bypass : A parallel track that outside from the circuit element , the IC (integrated circuit) has been rapidly developing in this years and thus a miniaturization or chip of electrolytic capacitors for by pass was conducted .
- c. For Coupling : Combination of the electrolytic capacitor , chip resistor and inductor and thus coupling together .
- d. For Arising of Toothed Wave : Composing of RC charge/ discharge circuit through the electrolytic capacitor as well as the resistor and a toothed wave to be created by the RC charge/discharge circuit .
- e. For Reverse (Change) of Circuit : The equipment for change the AC voltage to DC voltage .

3. For AC voltage :

- a. For Power Improving : Connect the end loading of layout transporting & electrolytic capacitor for power improving .
- b. For Wave Filter : Prevention of external interference in SCR circuit , use the LC wave filter circuit to inhibit or erase the interference .
- c. For Phase Across : Phase change of the inductive electromotor (motor) with single phase .

ALUMINUM ELECTROLYTIC CAPACITORS

1-4 Basic Electrical Characteristics

1. Capacitance (E.S.C.)



C : Capacitance(F)
 R : Equivalent series resistance(Ω)
 L : Equivalent series inductance(H)

Fig.1-3 Simplified equivalent circuit diagram of an electrolytic capacitor

The capacitive component of the equivalent series circuit (equivalent series capacitance ESC) is determined by applying an alternate voltage of 0.5V at a frequency of 120 Hz .

Temperature dependence of the capacitance

The capacitance of an electrolytic capacitor depends on the temperature : with decreasing temperature , the viscosity of the electrolyte increases reducing its conductivity . The capacitance will decrease if the temperature decreases . Furthermore temperature drifts cause armature dilatation and therefore capacitance changes (up to20% , depending on the series considered, from 0 to 80°C) . This phenomenon is more evident for electrolytic capacitors than for other types .

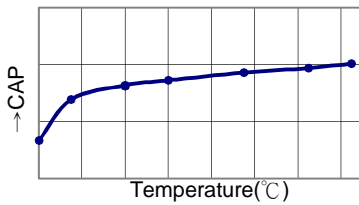

Fig 1-4 Capacitance change vs. temperature

Frequency dependence of the capacitance

The effective capacitance value is derived from the impedance curve , as long as the impedance is still in the range where the capacitance component is dominant .

$$C = \frac{1}{2\pi f Z}$$

C = Capacitance (F)
 f = Frequency (Hz)
 Z = Impedance (Ω)

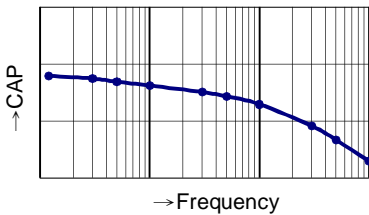
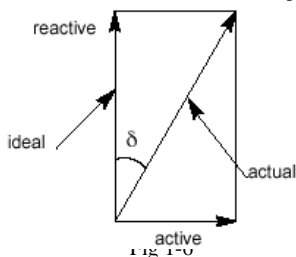

Fig 1-5 Capacitance change vs. frequency

2. Dissipation factor (tanδ)

The dissipation factor is the ratio between the active and the reactive power for a sinusoidal waveform voltage . It can be thought as a measurement of the gap between an actual and an ideal capacitor .



$$D.F. = \tan\delta \times 100 (\%) = \omega CR \times 100 (\%) = 2\pi f CR \times 100 (\%)$$

where: R = Equivalent Series Resistance
 C = Equivalent Series Capacitance
 $\omega = 2\pi f$

The tanδ is measured with the same set up as for the series capacitance ESC .

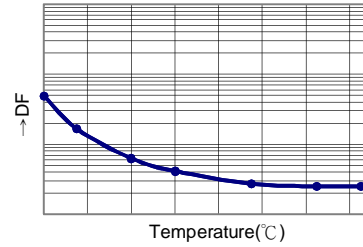

Fig 1-7 Dissipation factor vs. temperature

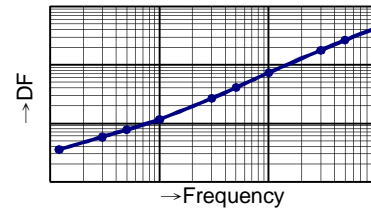

Fig 1-8 Dissipation factor vs. frequency

3. Equivalent series resistance (E.S.R.)

The equivalent series resistance is the resistive component of the equivalent series circuit . The ESR value depends on frequency and temperature and is related to the tanδ by the following equation :

$$ESR = \frac{\tan\delta}{2\pi f ESC}$$

ESR = Equivalent Series Resistance (Ω)
 tanδ = Dissipation Factor
 ESC = Equivalent Series Capacitance (F)
 f = Frequency (Hz)

The tolerance limits of the rated capacitance must be taken into account when calculating this value .

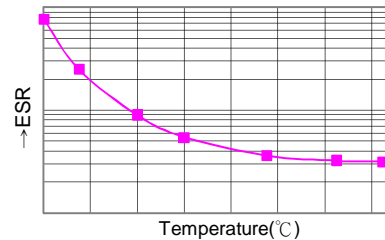

Fig 1-9 ESR change vs. temperature

The resistance of the electrolyte decreases strongly with increasing temperature.

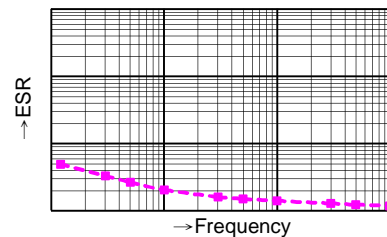

Fig 1-10 ESR change vs. frequency

ALUMINUM ELECTROLYTIC CAPACITORS

4. Impedance (Z)

The impedance of an electrolytic capacitor results from here below circuit formed by the following individual equivalent series components :

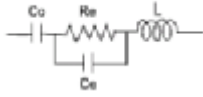
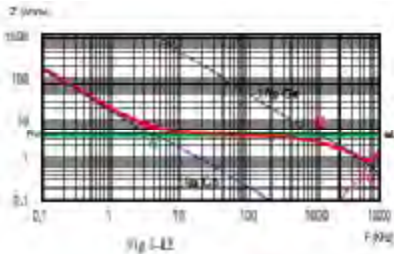

Fig 1-11

- C_o = Aluminum oxide capacitance (surface and thickness of the dielectric)
- R_e = Resistance of electrolyte and paper mixture (other resistances not depending on the frequency are not considered : tabs , plates , and so on)
- C_e = Electrolyte soaked paper capacitance
- L = Inductive reactance of the capacitor winding and terminals.

The impedance of an electrolytic capacitor is not a constant quantity that retains its value under all the conditions : it changes depending on the frequency and the temperature .

The impedance as a function of frequency (sinusoidal waveform) for a certain temperature can be represented as follows :



- Capacitive reactance predominates at low frequencies
 - With increasing frequency , the Capacitive reactance $X_c = 1/\omega C_o$ decreases until it reaches the order of magnitude of the electrolyte resistance R_e (A)
 - At even higher frequencies , the resistance of the electrolyte predominates : $Z = R_e$ (A - B)
 - When the capacitor's resonance frequency is reached (ω_0) , capacitive and inductive reactance mutually cancel each other $1/\omega C_e = \omega L$, $\omega_0 = \text{SQR}(1/LC_e)(C)$.
 - Above this frequency , the inductive reactance of the winding and its terminals ($X_L = Z = \omega L$) becomes effective and leads to an increase in impedance .
- Generally speaking it can be estimated that $C_e \approx 0.01 C_o$.

The impedance as a function of frequency (sinusoidal waveform) for different temperature values can be represented as follows (typical values) :

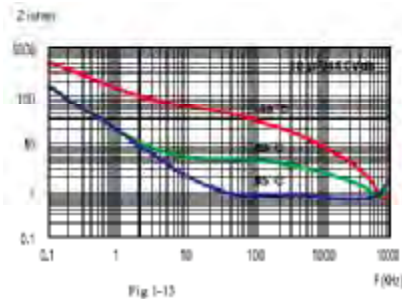

R_e is the most temperature dependant component of electrolytic capacitor equivalent circuit . The electrolyte resistivity will decrease if the temperature rises . In order to obtain a low impedance value all over the temperature range , R_e must be as little as possible , but too low R_e values means a very aggressive electrolyte and then a shorter life of the electrolytic capacitor at the high temperatures . A compromise must be reached .

5. Leakage current (L.C.)

Due to the aluminum oxide layer that serves as a dielectric , a small current will continue to flow even after a DC voltage has been applied for long periods . This current is called leakage current . A high leakage current flows after applying a voltage to the capacitor and then decreases in few minutes (e.g. after a prolonged storage without any applied voltage) . In the course of the continuous operation , the leakage current will decrease and reach an almost constant value .

After a voltage free storage the oxide layer may deteriorate , especially at high temperature . Since there are no leakage current to transport oxygen ions to the anode , the oxide layer is not regenerated . The result is that a higher than normal leakage current will flow when a voltage is applied after prolonged storage . As the oxide layer is regenerated in use , the leakage current will gradually decrease to its normal level .

The relationship between the leakage current and the voltage applied at constant temperature can be shown schematically as follows :

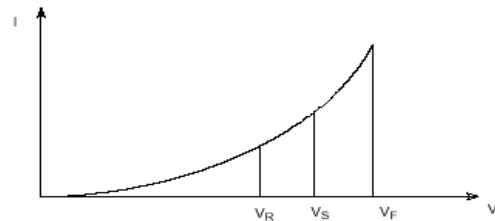

Fig 1-14

Where :

V_F = Forming voltage

If this level is exceeded a large quantity of heat and gas will be generated and the capacitor could be damaged .

V_R = Rated Voltage

This level represents the top of the linear part of the curve .

V_S = Surge voltage

It lies between V_R and V_F : the capacitor can be subjected to V_S for short periods only .

ALUMINUM ELECTROLYTIC CAPACITORS

1-5 Reliability

(1) The bathtub curve :

Aluminum electrolytic capacitors feature failure rates shown by the following bathtub curve.

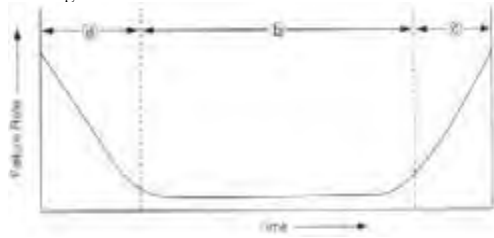

Fig.1-15 Bathtub curve

- a. Initial failure period
Deficient Capacitors include any products before dispatch that may have some deficiency caused by the design, production process or used in inappropriate environments.
- b. Random failure period
The capacitors have a low defect ratio in the period after it has been stabilized.
- c. Wear out failure period
The performance of capacitors will decrease with an increase in usage period. The malfunction rate may vary due to the structural design.

1-6 Circuit Design

(1) Environmental and Mounting Conditions

- ★ Please make sure the environmental and mounting conditions to which the capacitor will be exposed to are within the conditions specified in TEAPO's catalog.

(2) Operating Temperature, Equivalent Series Resistance(ESR), Ripple Current and Load Life

- ★ MTF(Mean-Time-To-Failure) means the useful life at room temperature 25°C

Load life:

If the capacitor's max. operating temperature is at 105°C (85°C), then after applying capacitor's rated voltage (WV) for L₀ hours at 105°C (85°C), the capacitor shall meet the requirements in detail specification.

where L₀ is called "load life" or "useful life (lifetime) at 105°C (85°C)".

$$L_x = L_0 \times 2^{(T_0 - T_x)/10} \times K \quad \Delta T_x / 5$$

where $\Delta T_x = \Delta T_0 \times (I_x / I_0)^2$, $I_x > I_0, K=4$; $I_x \leq I_0, K=2$

Ripple life:

If the capacitor's max. operating temperature is at 105°C (85°C), then after applying capacitor's rated voltage (WV) with the ripple current for L_r hours at 105°C (85°C), the capacitor shall meet the requirements in detail specification. where L_r is called "ripple life" or "useful ripple life (ripple lifetime) at 105°C (85°C)".

$$L_x = L_r \times 2^{(T_0 - T_x)/10} \times K \quad (\Delta T_0 - \Delta T_x) / 5$$

where $\Delta T_x = \Delta T_0 \times (I_x / I_0)^2$, $I_x > I_0, K=4$; $I_x \leq I_0, K=2$

The (ripple) life expectancy at a lower temperature than the specified maximum temperature may be estimated by the following equation, but this expectancy formula does not apply for ambient below +40°C.

- L₀ = Expected life period (hrs) at maximum operating temperature allowed
- L_r = Expected ripple life period (hrs) at maximum operating temperature allowed
- L_x = Expected life period (hrs) at actual operating temperature
- T₀ = Maximum operating temperature (°C) allowed
- T_x = Actual operating ambient temperature (°C)
- I_x = Actual applied ripple current (mA Arms) at operating frequency f₀ (Hz)
- I₀ = Rated maximum permissible ripple current I_R (mA Arms) x frequency multiplier (C_f) at f₀ (Hz)
- ※Ripple Current calculation: no need Temperature Multiplying Factor
- ※For Ripple life · I_x Should be 80% equal or more of I₀, if less than 80%, calculate with 80%.

$$\Delta T_0 \leq 5^\circ\text{C} = \text{Maximum temperature rise } (^\circ\text{C}) \text{ for applying } I_0 \text{ (mA Arms)}$$

$$\Delta T_c = \text{Temperature rise } (^\circ\text{C}) \text{ of capacitor case for applying } I_x \text{ (mA Arms)}$$

$$\Delta T_x = \text{Temperature rise } (^\circ\text{C}) \text{ of capacitor element for applying } I_x \text{ (mA Arms)}$$

$$= K_c \Delta T_c = K_c (T_c - T_x)$$

where T_c is the surface temperature (°C) of capacitor case

T_x is ditto.

K_c is transfer coefficient between element and case of capacitor from table below :

Dia	≤ 8ψ	10ψ	12.5ψ	16ψ	18ψ	22ψ	25ψ	30ψ	35ψ
K _c	1.10	1.15	1.20	1.25	1.30	1.35	1.40	1.50	1.65

※ The estimated life is limited to 15 years, if it exceeds 15 years, take 15 years as standard.

★ The formula of Equivalent Series Resistance (ESR)

The operating frequency of ESR, DF, f & C must be the same, usually, they test at 120 Hz.

$$ESR = DF / 2\pi f C \dots \dots \dots (2)$$

Where DF: Dissipation Factor(tanδ)

f: Operating frequency(Hz)

C: Capacitance(F)

★ Estimation of life considering the ripple current

The ripple current affects the life of a capacitor because the internal loss (ESR) generates heat. The generated heat will be:

$$P = I^2 R \dots \dots \dots (3)$$

Where I: Ripple current(Arms.)

R: ESR(Ω)

At this time the increase in the capacitor temperature will be:

$$\Delta T = I^2 R / AH \dots \dots \dots (4)$$

Where ΔT: Temperature increase in the capacitor core(degree)

I: Ripple current(Arms)

R: ESR(Ω)

A: Surface area of the capacitor (cm²)

H: Radiation coefficient(Approx. 1.5~2.0 · 10⁻³ W/cm² · °C)

The above equation (4) shows that the temperature of a capacitor increases in proportion to the square of the applied ripple current and ESR, and in inverse proportion to the surface area. Therefore, the amount of the ripple current determines the heat generation, which affects the life. The values of ΔT varies depending on the capacitor types and operating conditions. The usage is generally desirable if ΔT remains less than 5°C. The measuring point for temperature increase due to ripple current is shown below.

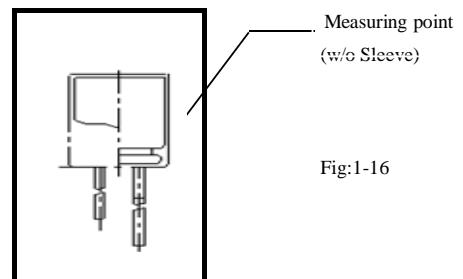

Fig:1-16

(3) Application

- ★ Aluminium Electrolytic Capacitors are normally polarized. Reverse voltage or AC Voltage should not be applied. When polarity may flip over, non-polar type capacitors should be used, but the non-polar type cannot be used for AC circuits.

(4) Applied Voltage

- ★ Do not exceed the rated voltage of capacitor.

ALUMINUM ELECTROLYTIC CAPACITORS

(5) Insulation

- ★ Aluminum Electrolytic Capacitors should be electrically isolated from among the following points.
 - a. Aluminum case, cathode lead wire, anode lead wire and circuit pattern
 - b. Auxiliary terminals of snap-in type, anode terminal, outward terminal and circuit pattern.

(6) Conditions of use

- ★ Aluminum Electrolytic Capacitors must not be used under the following conditions:
 - a. Damp conditions such as water, saltwater spray, or oil spray or fumes. High humidity or humidity condensation situations
 - b. Ambient conditions that include toxic gasses such as hydrogen sulfide, sulfuric acid, nitrous acid, chlorine, ammonium, etc.
 - c. Ambient conditions that expose the capacitors to ozone, ultraviolet rays and radiation.
 - d. Severe vibration or shock that exceeds the conditions specified in the catalog or specifications sheets.

(7) Recommended design considerations

- ★ When designing a circuit board. Please pay attention to the following:
 - a. Make the hole spacing on the PC board match the lead space of the capacitor.
 - b. There should not be any circuit pattern or circuit wire above the capacitors.
 - c. In case the capacitor's vent is facing the PC board, make a gas release hole on PC board.
 - d. Do not install screw terminal capacitor with end seal side down. When you install a screw terminal capacitor in a horizontal mount, the positive terminal must be in the upper position.
 - e. Do not locate any wiring and circuit patterns directly above the capacitor's vent.

(3) Soldering

- ★ All TEAPO's cp wires of electrolytic capacitors are without lead (Pb).
- ★ Soldering conditions(temperatures, times) should be within the specified conditions which are described in the catalog or specification sheet.
- ★ If it is necessary that the leads must be formed due to a mismatch of the lead space to hole space on the board, bend the lead prior to soldering without applying too much stress to the capacitor.
- ★ If soldering capacitor has to be withdrawn from the PW board by soldering iron, the capacitor should be removed after the solder has melted sufficient order to avoid stress to the capacitor or lead wires.
- ★ Soldering iron should never touch the capacitor's body.
- ★ Besides SMD for polymer type, do not reflow soldering for other type capacitor.
- ★ No high temperature

(4) Flow soldering

- ★ Do not dip capacitor's body into melted solder.
- ★ Duration of flow soldering for the capacitors should be limited at 260°C, 10sec
- ★ Flux should not be adhered to capacitor's body but only to its terminals.
- ★ Other devices which are mounted near capacitors should not touch the capacitors.

(5) Lead free type reflow soldering condition (SMD For E-CAP) For Aluminum Electrolytic Capacitors

- ★ For reflow, use a thermal condition system such as infrared radiation or hot blast. Vapor heat transfer systems are not recommended.
- ★ Observe proper soldering conditions(temperature, time, etc). Do not exceed the specified limits.
- ★ Repeated reflowing :
 - *Avoid reflowing twice if possible.
 - *If repeated reflowing is unavoidable, contact us after measuring the first and the second reflow profiles and reflow interval at your side.
 - *Do not attempt to reflow three times.

1-7 Caution for Mounting

(1) Caution before assembly

- ★ Aluminum Electrolytic Capacitors cannot be recycled after mounting and applying electricity in unit. The capacitors that are removed from PC board for the purpose of measuring electrical characteristics at a periodical inspection should only be recycled to the same position.
- ★ Aluminum Electrolytic Capacitors may accumulate charge naturally during storage. In this case, discharge through a 1KΩ resistor before use.
- ★ Leakage current of Aluminum Electrolytic Capacitors may be increase during long storage time. In this case, the capacitors should be subject to voltage treatment through a 1KΩ resistor before use.

(2) In the assembly process

- ★ Please confirm ratings before installing capacitors on the PC board.
- ★ Please confirm polarity before installing capacitors on the PC board.
- ★ Do not drop capacitors on the floor, nor use a capacitor that was dropped.
- ★ Be careful not to deform the capacitor during installation.
- ★ Please confirm that the lead spacing of the capacitor matches the hole spacing of the PC board prior to installation.
- ★ The snap-in type of capacitors should be mounted firmly on the PC board without a gap between the capacitor body and the surface of PC board.
- ★ Avoid excessive force when clinching lead wire during auto-insertion process.
- ★ Avoid excessive shock to capacitors by automatic insertion machine, during mounting, parts inspection or centering operations.
- ★ Please utilize supporting material such as strap or adhesive to mount capacitors to PC board when it is anticipated that vibration or shock is applied.

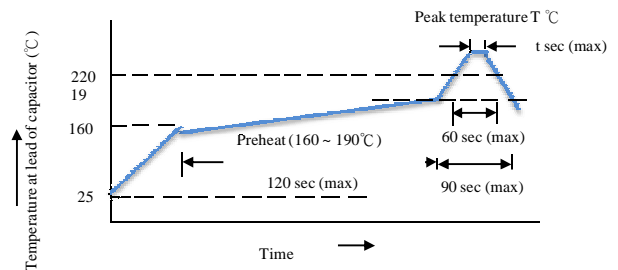

Fig:1-17

Size	T	t
φ4~φ5 (4V~50V)	250	10
	260	5
φ6.3~φ10 (4V~50V)	250	5
φ4~φ10 63~100V	250	5

ALUMINUM ELECTROLYTIC CAPACITORS

For Conductive Polymer Aluminum Solid Capacitors

Resistance to soldering heat condition

Test condition

A) Vapor phase soldering method

Solder paste should be applied to the printed wiring boards and then the capacitors are mounted on it. After that, the capacitor should be maintained in the vapor phase bath at a temperature of $230 \pm 2 \text{ }^\circ\text{C}$ for 75 ± 1 seconds.

B) Soldering iron method

Temperature: $400 \pm 10 \text{ }^\circ\text{C}$

Duration: 3_{-0}^{+1} seconds

Performance: The capacitors shall meet the following specification after A or B test.

Item	Performance
Capacitance change	Within $\pm 10\%$ of initial capacitance (2.5V: Within $\pm 15\%$ of initial capacitance)
Tangent of loss angle	Less than or equal to 1.3 times of the value
E.S.R.	Less than or equal to 1.3 times of the value
Leakage current	Less than or equal to the value

Recommendable reflow condition

Reflow profile

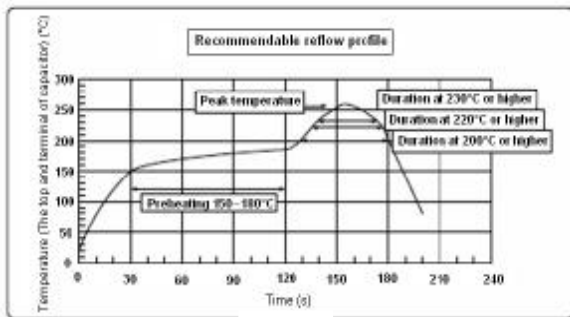

Fig : 1-18

Peak temperature of the top and terminal of a capacitor	$230 \text{ }^\circ\text{C}$ or less	$250 \text{ }^\circ\text{C}$ or less
Preheating	150°C to 180°C, 30 to 60 seconds	
Time of being at 200°C and higher	Within 60 seconds	Within 60 seconds
Time of being at 220°C and higher	Within 60 seconds	Within 60 seconds
Time of being at 230°C and higher	Within 60 seconds	Within 60 seconds
The number of reflux	Times to less	Only 1 time

Note:

*Measurement position of temperature: The top surface of capacitor and board's surface nearby terminal.

*Measurement method: Thermo-junction is fixed on measurement position by silver paste or an adhesive of resin.

Thermo-junction is Classification K, material CA with diameter 0.1mm.

*An interval of reflow: In case two times reflow is necessary, CP-CAP shall be taken into reflow when its return to normal temperature.

*Heat stress to CP-CAP will be influenced by the different of reflow equipment, board material, size, and numbers of mounting. The following action must be practiced through a practical test mounting before mass-production.

- (1) Check your reflow condition whether it is within the above TEAPO Recommendable Reflow Condition or not.
- (2) Confirm CP-CAP's electric characteristic change before and after reflow.

(7) Cleaning

★ Satisfied characteristic of JIS C 5101.

★ Aluminum Electrolytic Capacitors may be damaged by corrosion which is caused by any halogenated hydrocarbon solvents (Ex: HCH(Cl)2...). All of our products are non-solvent-proof, we recommend cleaning method as following:

Applicable : Any type, any ratings

Cleaning agents : Pine Alpha ST-100S, Clean Through 750H/750L/710M, Sanelek B-12, Aqua Cleaner 210SEP, Techno Care FRW14~17, Iso-propyl Alcohol

Cleaning conditions: Total cleaning time shall be within 5 minutes by immersion, ultrasonic or other method. (Temperature of the cleaning agent shall be $60 \text{ }^\circ\text{C}$ or lower.) After cleaning, capacitors should be dried using hot air for minimum of 10 minutes along with the PC board.

Hot air temperature should be below the maximum operating temperature of the capacitor. Insufficient drying after water rinse may cause appearance problems, sleeve may shrink, or the bottom-plate may bulge, etc...

Please let us know in advance the solvent name and conditions for your PCB Cleaning.

1-8 Emergency Action

- (1) If you see smoke due to the operation of safety vent, turn off the main switch or pull out the plug from the outlet.
- (2) Do not put your face near the safety vent as gas which is over $100 \text{ }^\circ\text{C}$ will be emitted when the safety vent operates. If the gas has entered your eyes, please flush your eyes immediately in pure water. If you breathed the gas, immediately wash out your mouth and throat with water. Do not ingest electrolyte. If your skin is exposed to electrolyte, please wash it away using soap and water.

1-9 Storage Condition

- (1) Aluminum electrolytic capacitors should not be stored in high temperatures or where there is a high level of humidity. The suitable storage condition is $5 \sim 35 \text{ }^\circ\text{C}$ and less than 75% in relative humidity.
- (2) Aluminum electrolytic capacitors should not be stored in damp conditions such as water, saltwater spray or oil spray.
- (3) Do not store aluminum electrolytic capacitors in an environment full of hazardous gas (hydrogen sulfide, sulfuric acid gas, nitrous acid, chlorine gas, ammonium, etc.).
- (4) Aluminum electrolytic capacitors should not be stored under exposure to ozone, ultraviolet rays or radiation.
- (5) If a capacitor has been stored for more than one year under normal temperature (shorter if high temperature) and it shows increased leakage current, then a treatment by voltage application is recommended.

1-10 Environment - Related Substances

All TEAPO's capacitors comply to RoHS (Restriction of Hazardous Substances) requirements where Chromium VI (Cr^{+6}), Cadmium (Cd), Mercury (Hg), Lead (Pb), polybrominated biphenyls (PBBs) and Polybrominated biphenyl/diphenyl ethers (PBDEs / PBDEs) have not detected (lower than MDL (Method Detection Limit)) per SGS certification test report.

1-11 Disposal

Please dispose capacitors in either of the following ways:

- (1) Incinerate capacitors after crushing parts of making a hole on the capacitor body.
- (2) Bury capacitors in the ground. Please have a disposal specialist do it.

ALUMINUM ELECTROLYTIC CAPACITORS

The Characteristics of Endurance Test

Capacitance Change Ratio

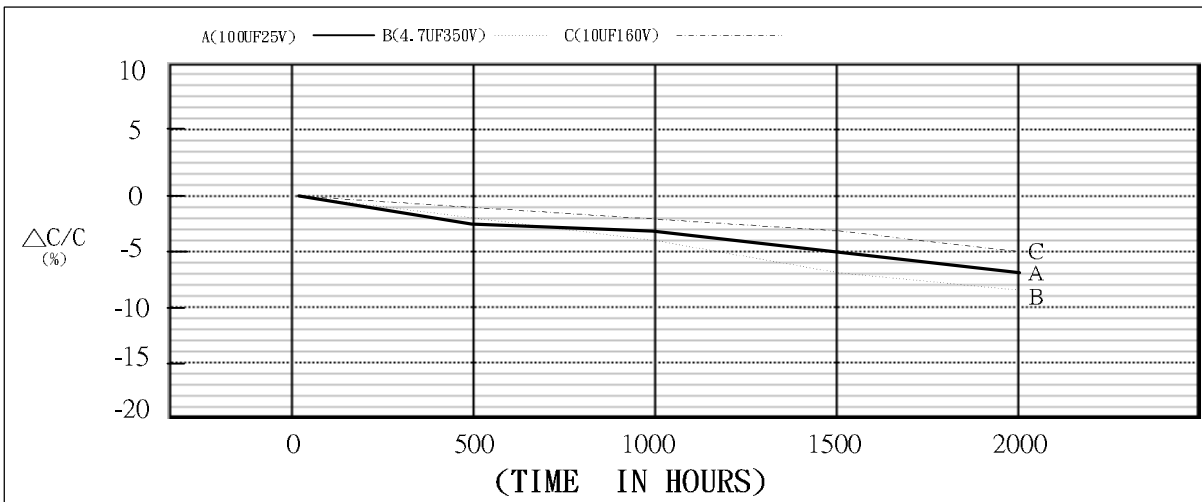

Dissipation Factor Change

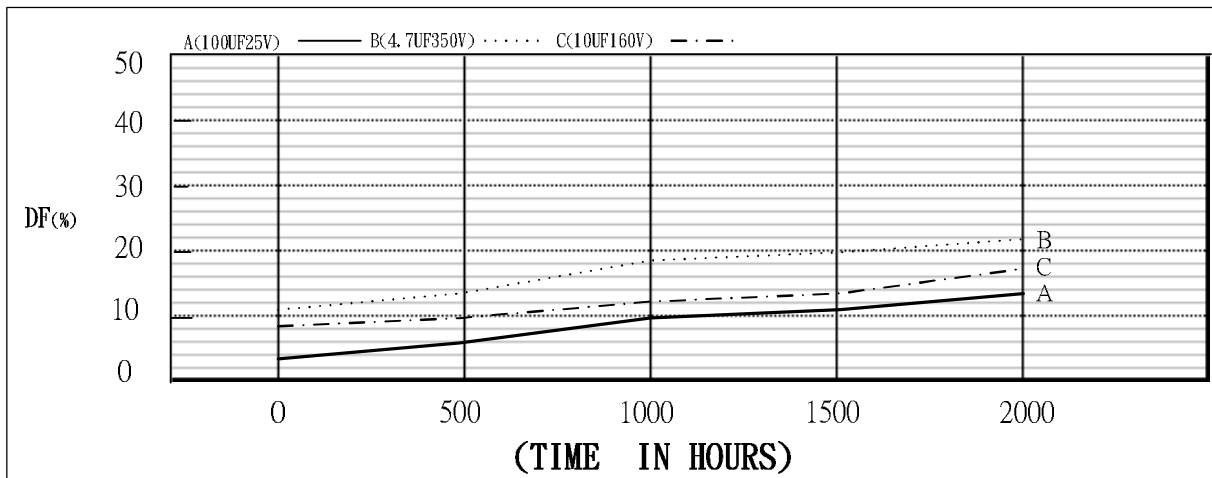

Leakage Current Change

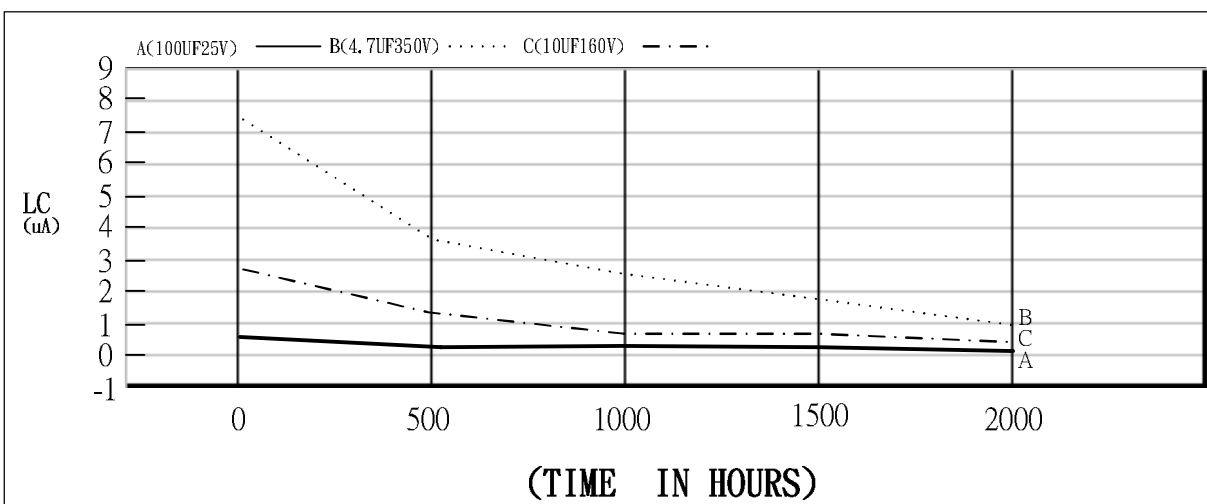

ALUMINUM ELECTROLYTIC CAPACITORS

Typical Failure Modes and Their Factors

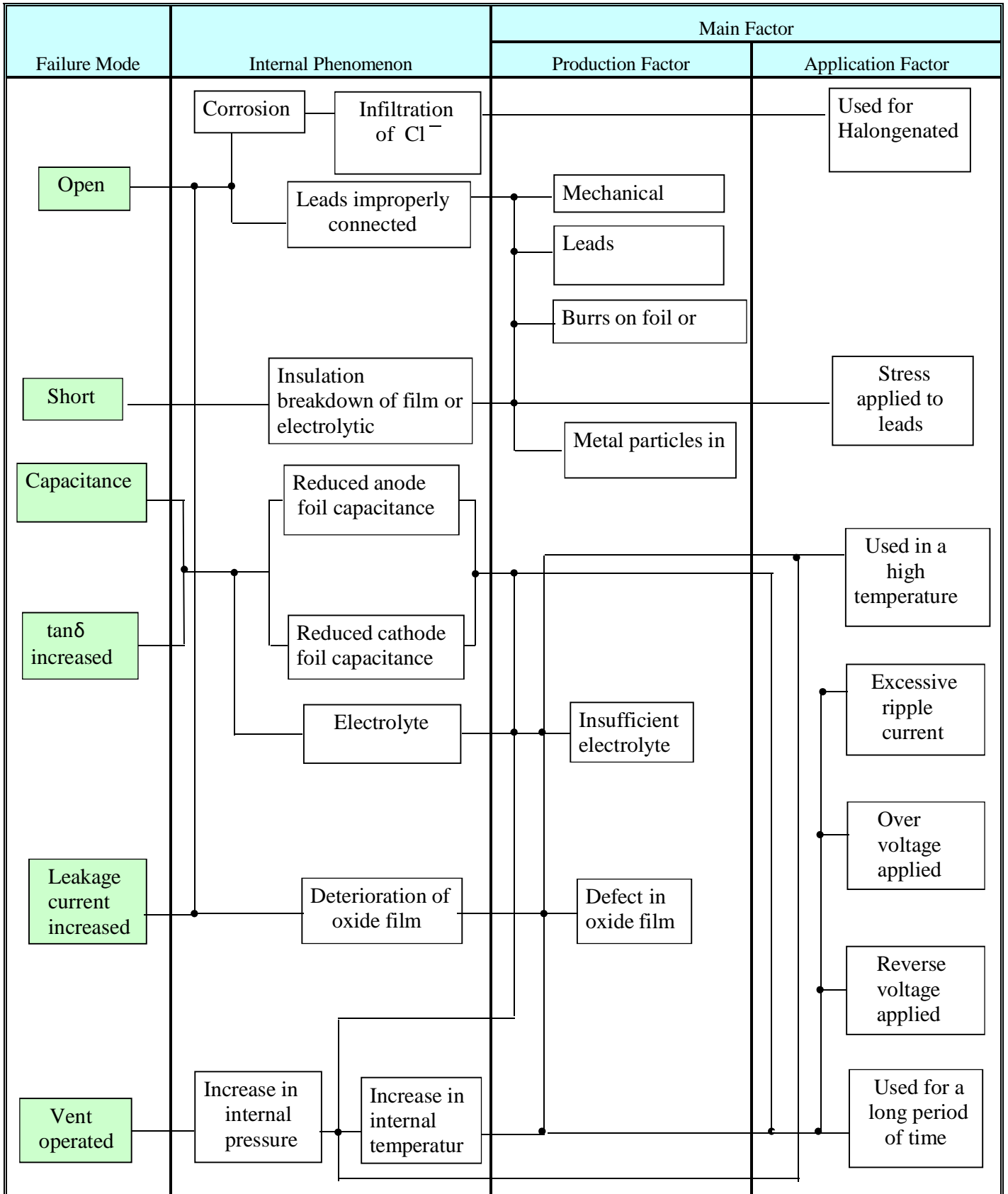

ALUMINUM ELECTROLYTIC CAPACITORS

Part Number Instruction

1	2~3	4~6	7	8~10	11~12	13	14	15	16~17	18
<u>K</u>	<u>SK</u>	<u>107</u>	<u>M</u>	<u>6R3</u>	<u>S1</u>	<u>A</u>	<u>1</u>	<u>C</u>	<u>11</u>	<u>K</u>
TYPE	SERIES	CAP	TOL.	VOLTAGE	LEAD	SPEC.	SLEEVE	CASE SIZE	LENGTH	OTHERS

Code 1 Type

Code	Model Type
D	Standard Dip Type (PVC sleeve)
K	Standard Dip Type (PET sleeve)
V	SMD (V-chip) Type (Nylon coating)
L	Snap-in Type (PVC sleeve)
S	Snap-in Type (PET sleeve)
P	Conductive Polymer Aluminum Solid Capacitor

Code 2~3 Series Name (as content page 6 to page 8)

Code 4~6 Capacitance

0.47μF	=	474
4.7μF	=	475
47μF	=	476
470μF	=	477
4700μF	=	478

Code 7 Tolerance

M = ±20% , K = ±10% , V = +20 ~ -10%

Code 8~10 Voltage

2.5V	=	2R5	100V = 100
5V	=	005	450V = 450
6.3V	=	6R3	
63V	=	063	

Code 11~12 Lead Process

Explanation for code 11

S : Standard T : Ammo tape R : Reel tape
 C : Straight cut K : Kink(Crimp)cut F : Formed cut

Code 11&12	Description
S	0 Standard SMD type
	1 Standard Dip & Snap-in type
T	1 Standard ammo tape (pitch 5mm for dia. ~ 13mm)
	2 Ammo tape with straight lead (available for dia. 4~8mm)
	4 Ammo formed tape with pitch 2.5mm (available for dia.4~5mm)
R	1 Standard reel tape (pitch 5mm for dia.~ 10mm)
	2 Reel tape with straight lead (available for dia. 4~8mm)
	3 Reel formed tape with pitch 2.5mm (available for dia.4~5mm)

ALUMINUM ELECTROLYTIC CAPACITORS

Code 11&12	Description	
C	3	Straight cut lead with L : 3.2+/-0.5mm
	5	Straight cut lead with L : 4.0+/-0.5mm
	7	Straight cut lead with L : 5.0+/-0.5mm
K	2	Kink cut lead with L : 4.5+/-0.5mm
F	6	Forming cut lead with L : 4.0+/-0.5 (Pitch : 5mm)

Code 13 Special Specification

A : Standard	D : Impedance	H : Customer requirements	U: Special packaging
B : DF (tanδ)	E : Ripple current	K: Above life specified in catalog	V: Sleeve
C : ESR	F : Leakage current	L : Pins or Wire diameter	W: Capacitance

Code 14 Sleeve Code

Code	Series	Color
1	SK	Dark blue with white printing
5	S5,D5,H5,S7,D7,H7,SH,SG,SP,SB,SY, SR,BX,LH,LG,LJ,LF,SQ,LQ,AK,ST,TH,TG,TP,TA,	Black with white printing
B	SE	Brown with white printing
C	SC	Green with golden printing
H	SZ	Royal blue with golden printing
N	GV,FV,SV,DV,RV,ZV,EV,JV,CV, CG,CP,CR,CF,CY,CZ,CT,CX,CH,VP	(SMD standard pack & POLYMER)

Code 15~17 Size Code

Code 15 : Case Size

Code	A	B	C	D	E	F	G	H	J
Case Size	3	4	5	6	6.3	7	8	10	12

Code	K	L	M	N	P	Q	R	S	T
Case Size	12.5	13	16	18	20	22	25	30	35

Code 16~17 : Length

For ECAP-DIP & POLYMER-DIP & SNAP-IN

Code	05	07	09	10	1A	11	1B	12	1C	13	14
Length	05	07	09	10	10.5	11	11.5	12	12.5	13	14

Code	15	16	17	20	25	30	32	35	36	40	50
Length	15	16	17	20	25	30	32	35	36	40	50

Note: For the part hasn't been mentioned above, the Code is the same with Length.

For V-CHIP SMD

Code	01	02	03	04
LENGTH	5.4	6.2	10.2	7.7

For POLYMER SMD

Code	A1	A2	A3	A4	A5	A6	A7	A8
LENGTH	5.8	6.0	6.7	7.7	10.0	10.4	12.0	12.2

E.G. (For Code15~17) :

Code	Size	Description
B01	4*5.4	For V-CHIP SMD
C11	5*11	For ECAP-DIP & POLYMER-DIP
Q25	22*25	For SNAP-IN
EA1	6.3*5.8	For POLYMER SMD

Code 18 Other special instructions (“K” for TEAPO standard,“ 0 ” for LUXON standard)

ALUMINUM ELECTROLYTIC CAPACITORS

Code C5 : Straight Cut

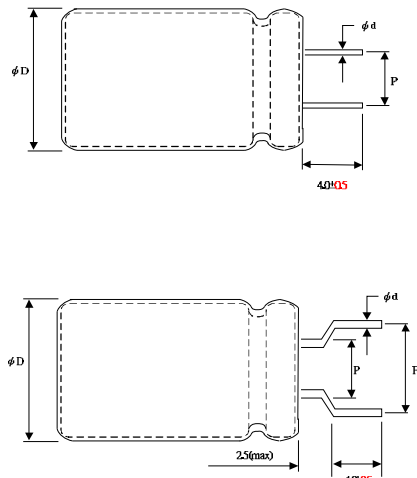

Code K2 : Kink cut, & Crimping

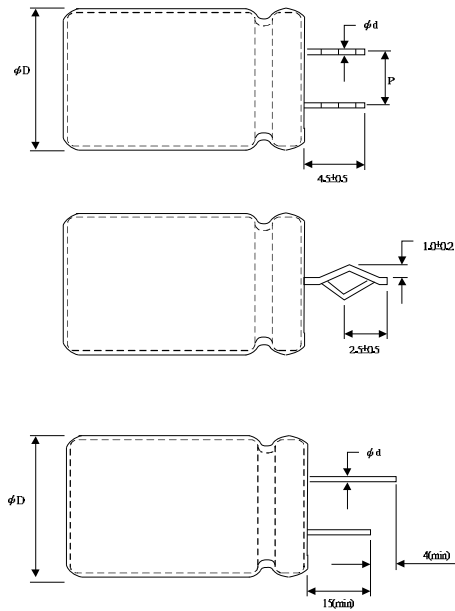

Code T1/R1 : Ammo / Reel Tape ($\psi 4 - \psi 6.3$)

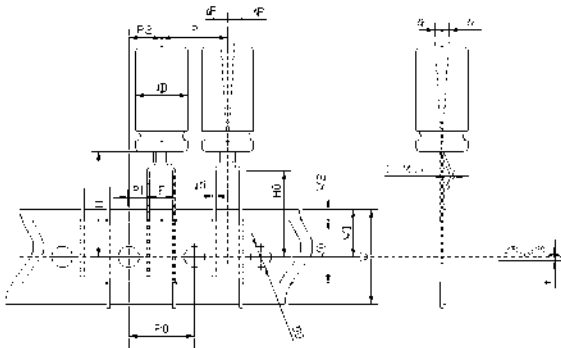

Code T1/R1 : Ammo / Reel Tape ($\psi 8$)

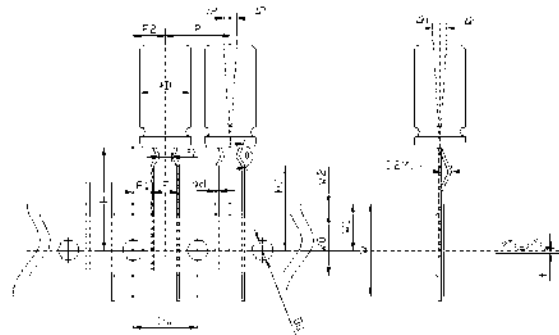

SYMBOL	CASE SIZE			TOLERANCE
	4×5	5×5~11	6.3×5~11	
ϕd	0.45	0.45 or 0.5		± 0.05
P	12.7			± 1.0
P0	12.7			± 0.3
P1	3.85			± 0.5
P2	6.35			± 1.0
F	5.0			$+0.6 / -0.2$
W	18.0			± 0.5
W0	12.0 min			-
W1	9.0			± 0.5
W2	2.0 max			-
H	18.5			± 0.75
H0	16.0			± 0.5
D0	4.0			± 0.3
ΔP	0.2 max			-
Δh	0.2 max			-
t	0.6			± 0.3

SYMBOL	CASE SIZE	TOLERANCE
	8×5~20	
ϕd	0.45~0.6	± 0.05
P	12.7	± 1.0
P0	12.7	± 0.3
P1	3.85	± 0.7
P2	6.35	± 1.0
P3	2.5	$+0.2 / -0.5$
θ	110°	$\pm 15^\circ$
F	5.0	$+0.6 / -0.2$
W	18.0	± 0.5
W0	12.0 min	-
W1	9.0	± 0.5
W2	2.0 max	-
H	18.5	± 0.75
H0	16.0	± 0.5
D0	4.0	± 0.3
ΔP	0.2 max	-
Δh	0.2 max	-
t	0.6	± 0.3

ALUMINUM ELECTROLYTIC CAPACITORS

Code T1/R1 : Ammo / Reel Tape (φ10)

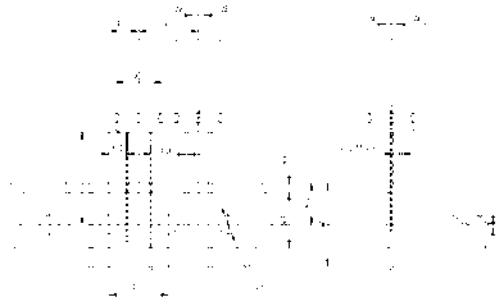

Code T1 : Ammo Tape (φ13~φ16)

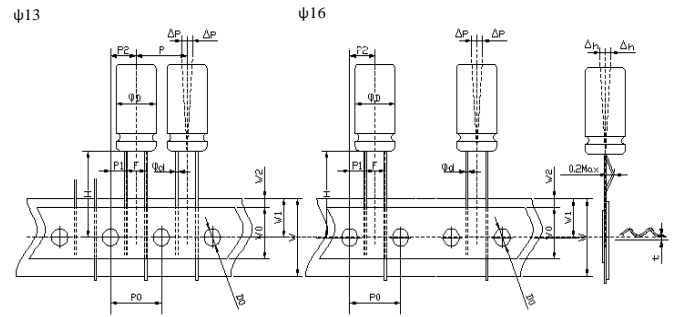

SYMBOL	CASE SIZE		TOLERANCE
	10×10~30		
φd	0.6		±0.05
P	12.7		±1.0
P0	12.7		±0.3
P1	3.85		±0.5
P2	6.35		±1.0
F	5.0		+0.6 / -0.2
W	18.0		±0.5
W0	12.0 min		-
W1	9.0		±0.5
W2	2.0 max		-
H	18.5		±0.75
D0	4.0		±0.3
△P	0.2 max		-
△h	0.2 max		-
t	0.7		±0.2

SYMBOL	CASE SIZE			TOLERANCE
	12.5x15~25	13x13~32	16x16~32	
φd	0.6	0.6	0.8	±0.05
P	15.0			±1.0
P0	15.0			±0.3
P1	5.0	3.75		±0.7
P2	7.5			±1.3
F	5.0	7.5		+0.6 / -0.2
W	18			±0.5
W0	12.0 min			-
W1	9.0			±0.5
W2	2.0 max			-
H	18.5			±0.75
D0	4.0			±0.3
△P	0.2 max			-
△h	0.2 max			-
t	0.7			±0.3

Code T2/R2 : Ammo / Reel Tape with straight lead

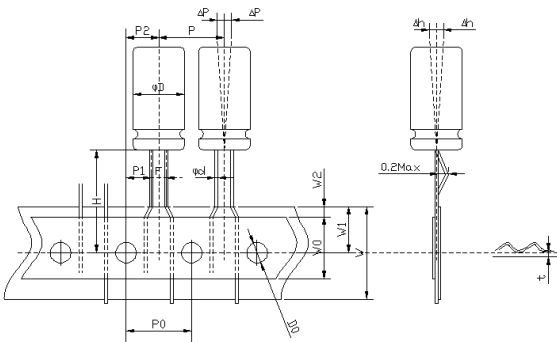

Code T4/R3 : Ammo / Reel Formed Tape (ψ4~ψ5 / pitch 2.5mm)

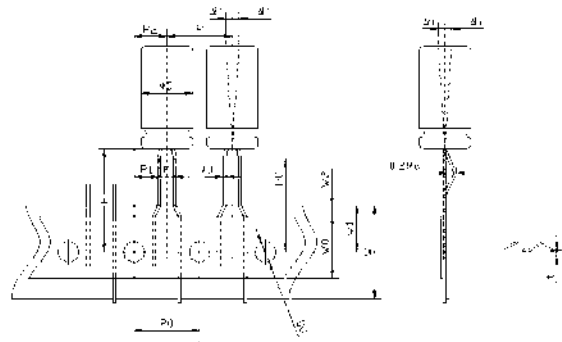

SYMBOL	CASE SIZE				TOLERANCE
	4×5~7	5×5~11	6.3×5~11	8×7~14	
φd	0.45	0.45 or 0.5	0.6		±0.05
F	1.5	2.0	2.5	3.5	+0.6 / -0.2
P1	5.6	5.35	5.1	4.6	±0.5
P0	12.7				±0.3
P	12.7				±1.0
P2	6.35				±1.0
W	18.0				±0.5
W0	12.0 min				-
W1	9.0				±0.5
W2	3.0 max				-
H	18.5				±0.75
D0	4.0				±0.3
△p	0.2 max				-
t	0.6				±0.2

SYMBOL	Case SIZE		Tolerance
	4×5~4×7	5×5~5×11	
φd	0.45	0.45 or 0.5	±0.05
P	12.7		±1.0
P0	12.7		±0.3
P1	5.1		±0.5
P2	6.35		±1.0
F	2.5		+0.6 / -0.2
W	18.0		±0.5
W0	12.0 min		-
W1	9.0		±0.5
W2	2.0 max		-
H	18.5		±0.75
H0	17.0		±0.5
D0	4.0		±0.3
△P	0.2 max		-
△h	0.2 max		-
t	0.6		±0.2

ALUMINUM ELECTROLYTIC CAPACITORS

SMD Packing Specifications

• Reel Dimensions in mm(not to scale)

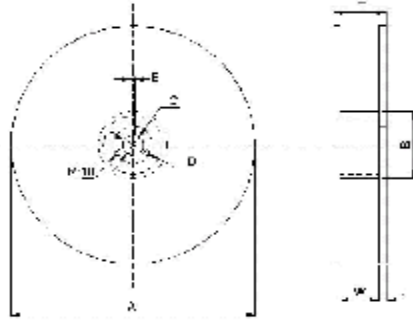

Size	A	B	C	D	E	W	T	t
4 ψ ~ 5 ψ	380 \pm 2	50min	13.0 \pm 0.5	21.0 \pm 0.8	2.0 \pm 0.5	14 \pm 1	20 \pm 1	3.0
6.3 ψ ~ 8 \times 6.7	380 \pm 2	50min	13.0 \pm 0.5	21.0 \pm 0.8	2.0 \pm 0.5	18 \pm 1	24 \pm 1	3.0
8 \times 10.2 ~ 10 ψ	380 \pm 2	50min	13.0 \pm 0.5	21.0 \pm 0.8	2.0 \pm 0.5	26 \pm 1	32 \pm 1	3.0
12.5 ψ	380 \pm 2	50min	13.0 \pm 0.5	21.0 \pm 0.8	2.0 \pm 0.5	32 \pm 1	38 \pm 1	3.0
16.0 ψ	380 \pm 2	50min	13.0 \pm 0.5	21.0 \pm 0.8	2.0 \pm 0.5	44 \pm 1	50 \pm 1	3.0

Reel Tape

Taping Dimensions in mm (not to scale)

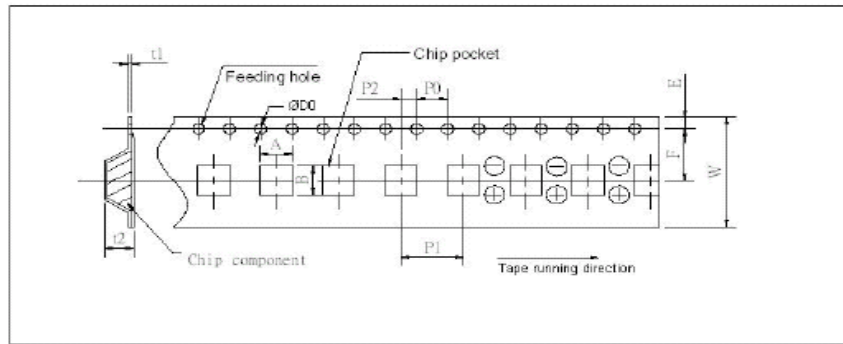

***Ask factory for technical specifications.**

Symbol Size	W	A	B	Po \pm 0.1	P1	P2 \pm 0.1	F	ψ Do	t1	E	t2
4x5.4~5.8	12.0	4.7	4.7	4.0	8.0	2.0	5.5	1.5+0.1-0	0.4	1.75	5.8
5x5.4~5.8	12.0	5.7	5.7	4.0	12.0	2.0	5.5	1.5+0.1-0	0.4	1.75	5.8
6.3x5.4~5.8	16.0	7.0	7.0	4.0	12.0	2.0	7.5	1.5+0.1-0	0.4	1.75	5.8
6.3x7.7	16.0	7.0	7.0	4.0	12.0	2.0	7.5	1.5+0.1-0	0.4	1.75	8.3
8x6.2~6.7	16.0	8.7	8.7	4.0	12.0	2.0	7.5	1.5+0.1-0	0.4	1.75	6.8
8x10.2~10.4	24.0	8.7	8.7	4.0	16.0	2.0	11.5	1.5+0.1-0	0.4	1.75	11.0
10x10.2~12.2	24.0	10.7	10.7	4.0	16.0	2.0	11.5	1.5+0.1-0	0.4	1.75	11.0
12.5x13.5	32.0	13.4	13.4	4.0	24.0	2.0	14.2	1.5+0.1-0	0.4	1.75	14.0
12.5x16.0	32.0	13.4	13.4	4.0	24.0	2.0	14.2	1.5+0.1-0	0.4	1.75	16.2
16.0x16.5	44.0	17.5	17.5	4.0	28.0	2.0	20.2	1.5+0.1-0	0.4	1.75	16.7

Packaging Specification

Size (mm)	Q'ty per reel	Inner box / measurement (mm)		Outer carton / measurement (mm)		Min. ordering amount
4x5.4~5.8	2000	20,000	390x195x395	40,000	420x410x414	10kpcs
5x5.4~5.8	1000	10,000	390x195x395	20,000	420x410x414	10kpcs
6.3x5.4 & 6.3x7.7	1000	10,000	390x235x405	20,000	420x410x492	10kpcs
8x6.2~6.7	1000	10,000	390x235x405	20,000	420x410x492	10kpcs
8x10.2~10.4	500	4,000	390x255x405	8,000	420x410x530	8kpcs
10x10.2~12.2	500	4,000	390x255x405	8,000	420x410x530	8kpcs
12.5x13.5	200	1,200	390x255x405	2,400	420x410x530	5kpcs
12.5x16.0	150	900	390x255x405	1,800	420x410x530	5kpcs
16.0x16.5	125	625	390x255x405	1,250	420x410x530	5kpcs

Conductive Polymer Aluminum Solid Capacitors

Conductive Polymer Aluminum Solid Capacitors

SMD Packing Specifications

· Reel Dimensions in mm(not to scale)

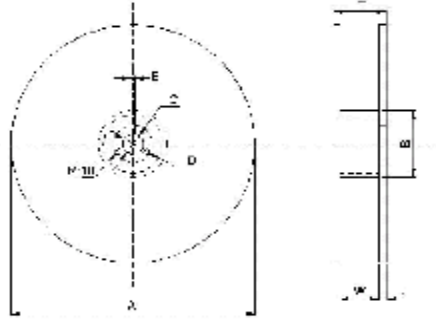

Size	A	B	C	D	E	W	T	t
5ψx5.8	380±2	50min	13.0±0.5	21.0±0.8	2.0±0.5	14±1	20±1	3.0
6.3x5.8ψ ~ 8× 6.7	380±2	50min	13.0±0.5	21.0±0.8	2.0±0.5	18±1	24±1	3.0
8×10.2 ~ 10x12.2	380±2	50min	13.0±0.5	21.0±0.8	2.0±0.5	26±1	32±1	3.0

Reel Tape

Taping Dimensions in mm (not to scale)

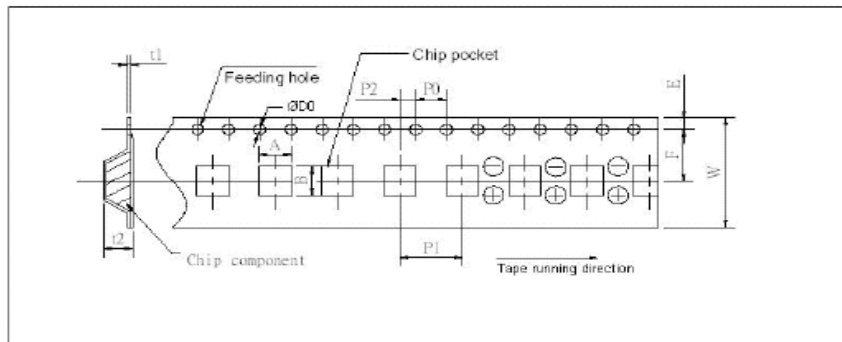

***Ask factory for technical specifications.**

Symbol Size	W	A	B	Po±0.1	P1	P2±0.1	F	ψDo	t1	E	t2
5x5.8	12.0	5.7	5.7	4.0	12.0	2.0	5.5	1.5+0.1-0	0.4	1.75	5.8
6.3~5.8	16.0	7.0	7.0	4.0	12.0	2.0	7.5	1.5+0.1-0	0.4	1.75	5.8
6.3x7.7	16.0	7.0	7.0	4.0	12.0	2.0	7.5	1.5+0.1-0	0.4	1.75	8.3
8x6.7	16.0	8.7	8.7	4.0	12.0	2.0	7.5	1.5+0.1-0	0.4	1.75	6.8
8x10.4	24.0	8.7	8.7	4.0	16.0	2.0	11.5	1.5+0.1-0	0.4	1.75	11.0
10x10	24.0	10.7	10.7	4.0	16.0	2.0	11.5	1.5+0.1-0	0.4	1.75	11.0
10x12.2	24.0	10.7	10.7	4.0	16.0	2.0	11.5	1.5+0.1-0	0.4	1.75	14.0

Packaging Specification

Size (mm)	Qty per reel	Inner box / measurement (mm)		Outer carton / measurement (mm)		Min. ordering amount
5x5.8	1000	10,000	390x195x395	20,000	420x410x414	10kpcs
6.3x5.8~ 6.3x7.7	1000	10,000	390x235x405	20,000	420x410x492	10kpcs
8x6.7	1000	10,000	390x235x405	20,000	420x410x492	10kpcs
8x10.4 ~10x10	500	4,000	390x255x405	8,000	420x410x530	8kpcs
10x12.2	400	3,200	390x255x405	6,400	420x410x530	6.4kpcs

ALUMINUM ELECTROLYTIC CAPACITORS

PACKAGING SPECIFICATION

Miniature Aluminum Electrolytic Capacitors

For Bulk: Standard Cutting & Forming

Classification	Standard Bulk				Cutting & Forming				Min. ordering amount
	Case size D*L(mm)	Vinyl bag Qty	Inner box Qty	Outer carton Qty	gross weight (kg)	Vinyl bag Qty	Inner box Qty	Outer carton Qty	
4×5	2,000	24,000	48,000	13	2,000	20,000	80,000	20	25
4×7	2,000	20,000	40,000	11	2,000	16,000	64,000	17	25
5×5	2,000	20,000	40,000	12	2,000	16,000	64,000	18	25
5×7	2,000	16,000	32,000	13	2,000	16,000	64,000	23	25
5×11	1,000	12,000	24,000	13	1,000	10,000	40,000	22	25
6.3×5	2,000	16,000	32,000	11	2,000	10,000	40,000	16	20
6.3×7	2,000	12,000	24,000	10	2,000	10,000	40,000	15	20
6.3×11	1,000	10,000	20,000	14	1,000	7,000	28,000	17	20
8×7	500	10,000	20,000	14	500	6,500	26,000	16	15
8×9,8×11	500	7,500	15,000	17	500	4,000	16,000	18	15
8×14	500	5,000	10,000	12	500	3,000	12,000	14	15
8×16	500	5,000	10,000	16	500	2,000	8,000	13	15
8×20	200	4,000	8,000	14	200	2,000	8,000	14	15
10×12.5	200	4,000	8,000	15	200	2,000	8,000	15	12
10×15	200	3,600	7,200	16	200	2,000	8,000	18	12
10×17	200	3,600	7,200	17	200	1,600	6,400	15	12
10×20	200	3,000	6,000	19	200	1,400	5,600	17	12
10×25	200	2,400	4,800	17	200	1,200	4,800	16	12
13×13,13×15	100	2,400	4,800	15	200	800	3,200	13	10
13×18,13×20	100	1,800	3,600	15	200	600	2,400	10	10
13×25	100	1,200	2,400	14	200	600	2,400	14	10
13×30	100	1,200	2,400	16	100	500	2,000	14	10
13×34,13×36	100	1,000	2,000	14	100	300	1,200	12	10
13×38,13×40	100	800	1,600	15	100	300	1,200	15	10
16X15,16X20	100	1000	2000	22	200	1000	2000	22	5
16X25	100	1000	2000	24	-	500	4000	44	5
16X30,16X32、	100	800	1600	20	-	500	3000	37	5
16X36,16X40	100	600	1200	22	-	500	3000	55	5
16X45	100	500	1000	22	-	-	-	-	5
18X15,18X20	100	800	1600	21	-	-	-	-	2.5
18X22,18X25	100	800	1600	23	-	500	2000	28	2.5
18X30	100	600	1200	25	-	-	-	-	2.5
18X32,18X36、18X40	100	500	1000	25	-	500	1000	25	2.5
18X45,18X50	100	300	600	21	-	600	1200	40	2.5
20X25	-	-	-	-	-	400	800	20	1.5
22X32	-	-	-	-	-	320	1920	55	1.5
22X30	-	-	-	-	-	400	800	25	1.5
22X35,22X40	100	300	600	21	-	400	800	27	1.5

For Bulk: Standard Cutting

Case size D*L(mm)	Lattice bar of inner carton		Row packing method		Inner box Qty	Outer carton Qty	gross weight (kg)	Min. ordering amount (kpcs)
	Height	Qty	Row number Layer number	Each row pcs				
11.7X26	60	38	20*2	25	1000	2000	9	5
16X15-20 L	55	18	10*2	25	500	1000	11	5
16X21-26 L	60	18	10*2	25	500	1000	12	5
16X27-32 L	65	18	10*2	25	500	1000	13	5
16X33-40 L	75	18	10*2	25	500	1000	14	5
18X15-16 L	50	18	10*2	25	500	1000	12	2.5
18X17-26 L	60	18	10*2	25	500	1000	13	2.5
18X27-32 L	65	11	12*1	25	300	600	13	2.5
18X33-42 L	75	11	12*1	25	300	600	13	2.5
18X43-50 L	85	11	12*1	25	300	600	14	2.5
20x30-40L	75	9	10*1	20	200	400	13	1.5
22x30-40L	75	9	10*1	20	200	400	15	1.5
22x41-50L	85	9	10*1	20	200	400	17	1.5
25x40-50L	85	9	10*1	20	200	400	19	1.5

ALUMINUM ELECTROLYTIC CAPACITORS

For Taping Ammo & Reel

Classification	Ammo Tape					Reel Tape			Min. ordering amount
	Case size	inner box	quantity	outer carton	quantity	gross	inner carton	outer carton	
4 ϕ	330×275×50	3,000	345×290×278	15,000	6	3,000	15,000	8	25
5 ϕ	330×230×50	2,000	345×248×280	10,000	6 ~ 7	2,400	12,000	8	25
6.3 ϕ	330×275×50	2,000	345×290×278	10,000	8	2,000	10,000	6	20
8 ϕ ×5-16L	330×230×50	1,000	345×248×280	5,000	7	1,600	8,000	12	15
8 ϕ ×20L	330×230×58	1,000	345×245×320	5,000	7	1,000	5,000	12	15
10 ϕ ×10~17L	330×230×50	600	345×248×280	3,000	7				12
10 ϕ ×20~25L	330×230×58	600	345×245×320	3,000	7	-	-	-	12
10 ϕ ×30L	330×230×65	600	345×245×290	2,400	7	-	-	-	12
13 ϕ ×32L below	335×235×65	400	352×248×290	1,600	5	-	-	-	10
13 ϕ ×36L above	335×235×74	400	352×248×325	1,600	5	-	-	-	10
16 ϕ ×32L below	335×275×65	300	355×297×290	1,200	5	-	-	-	5
16 ϕ ×36L above	335×275×74	300	355×297×337	1,200	5	-	-	-	5
18 ϕ ×20~32L above	340×288×63	260	360×305×280	1,040	5	-	-	-	5

Note : For 10 ϕ Reel Tape :

Size	inner carton(pcs)	outer carton(pcs)
10 ϕ ×10~16L	1,200	6,000
10 ϕ ×17~20L	1,000	5,000

Large Can Type Aluminum Electrolytic Capacitors

Dimension	weighe	inner box	outer carton	Min. ordering
22×25 to 30	20 ~ 25	300	1200	1.5kpcs
22×35 to 50	25 ~ 30	200	800	1.5kpcs
25×25 to 30	25 ~ 30	240	960	1.2kpcs
25×35 to 50	30 ~ 35	160	640	1.2kpcs
30×25 to 30	30 ~ 35	135	540	1.0kpcs
30×35 to 50	35 ~ 40	90	360	1.0kpcs
30 x 70	45~50	80	320	1.0kpcs
35×25 to 30	40 ~ 45	105	420	1.0kpcs
35×35to 50	45 ~ 50	70	280	1.0kpcs

Note: The dimension of 30x70 inner box is 254*254*190, the dimension of 30x70 outer carton is 530*270*400

Conductive Polymer Aluminum Solid Capacitor

For Bulk: Standard Cutting & Forming

Classification	Standard Bulk				Cutting & Forming				Min. ordering amount
	Case size	Vinyl bag	inner box	outer carton	gross	Vinyl bag	inner box	outer carton	
6.3×5.4	2,000	16,000	32,000	11	2,000	10,000	40,000	16	20
6.3×8	1,000	12,000	24,000	10	2,000	10,000	40,000	15	20
6.3×10.5	1,000	10,000	20,000	14	1,000	7,000	28,000	17	20
8×8, 8×10,	500	7,500	15,000	17	500	4,000	16,000	18	15
8x11.5									
10×12.5	200	4,000	8,000	15	200	2,000	8,000	15	12

For Taping Ammo & Reel

Classification	Ammo Tape					Reel Tape			Min. ordering amount
	Case size	inner box	quantity	outer carton	quantity	gross	inner carton	outer carton	
6.3 ϕ	340×275×50	2,000	355×297×290	10,000	8	2,000	10,000	6	20
8 ϕ ×5-16L	340×230×50	1,000	355×252×290	5,000	7	1,600	8,000	12	15
10 ϕ ×10~17L	340×230×50	600	355×252×290	3,000	7	1,000	5,000	14	12

CONDUCTIVE POLYMER ALUMINUM SOLID CAPACITORS

CG

Ultra low ESR
Series

- Features: 105°C, 2000hrs, Ultra Low ESR
- Recommended Applications: Motherboard, DC/DC Converter, Adapter, SPS, VCR, camcorder, DSC, PDA, HD Drive, MO Drive, DVD Drive, Navigation system, Portable Communication Devices
- Corresponding product to RoHS



Specifications

Item	Characteristics		
Category Temperature Range	-55 ~ +105°C		
Rated Voltage Range	2.5 ~ 25VDC		
Rated Capacitance Range	10 ~ 2200μF		
Capacitance Tolerance	±20% at 120Hz, 20°C		
Surge Voltage	Rated voltage (V) x 1.15		
Leakage Current (MAX) (20°C)	$I \leq 0.2 CV$ or 300μA whichever is greater (After rated voltage applied for 2 minutes)		
	$I =$ Leakage Current (μA) $C =$ Nominal Capacitance (μF) $V =$ Rated Voltage (V)		
Dissipation Factor (MAX) (tanδ) (120Hz, 20°C)	WV	2.5 ~ 10V	16~25V
	tanδ	0.08	0.12
Low Temperature Stability Impedance Ratio (MAX) (20°C)	Z(100KHz)		2.5 ~ 25V
	Z-25°C / Z+20°C		≤ 1.15
	Z-55°C / Z+20°C		≤ 1.25
Endurance	After applying rated voltage for 2000 hours at 105°C, the capacitor shall meet the following requirement.		
	Appearance	No significant damage	
	Capacitance Change	Within ±20% of the initial value	
	Dissipation Factor	Not more than 150% of the initial specified value	
	Equivalent Series Resistance	Not more than 150% of the initial specified value	
Leakage Current	Not more than the initial specified value		
Humidity Test	After subjecting 90 to 95% RH for 1000 hours at 60°C, the capacitors shall meet the requirement as Endurance.		
Surge Voltage Test	After subjecting to 1,000 cycles each consisting of charge with the surge voltage specified at normal temperature for 30 seconds through a protective resistor and discharge for 5 minutes 30 seconds, the capacitors shall meet the requirement as Endurance.		
Failure Rate (MAX)	1% per 1,000 hours (confidence level 60% at 105°C)		

Diagram of Dimensions

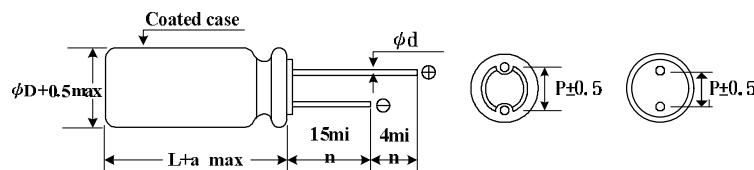

Marking : case with red printing

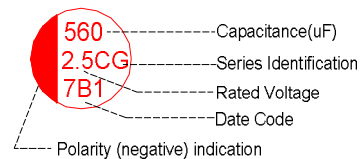

Size code	ψD X L	P	ψd	a
B01	4X5.4	1.5	0.45	1.0
C01	5X5.4	2.0	0.45	1.0
C07	5X7	2.0	0.5	1.0
E01	6.3X5.4	2.5	0.45	1.0
E08	6.3X8	2.5	0.6	1.0
E1A	6.3X10.5	2.5	0.6	1.0
G1B	8X11.5	3.5	0.6	1.0
H1A	10X10.5	5.0	0.6	1.0
H1C	10X12.5	5.0	0.6	1.0

Multiplier for Ripple Current

Frequency (Hz)	120 ≤ F < 1K	1K ≤ F < 10K	10K ≤ F < 100K	100K ≤ F ≤ 500K
Coefficient	0.05	0.3	0.7	1

CONDUCTIVE POLYMER ALUMINUM SOLID CAPACITORS



Ultra low ESR
Series

■ Dimensions, Rated Ripple Current, Equivalent Series Resistance

Capacitance (uF)	Rated Voltage								
	2.5V			4V			6.3V		
	SIZE	RIPPLE	ESR	SIZE	RIPPLE	ESR	SIZE	RIPPLE	ESR
47							5X5.4	1810	30
							6.3X5.4	1810	30
100							6.3X5.4	1810	40
120							6.3X5.4	1810	30
180							6.3X5.4	1810	30
220							5X7	3500	9
							6.3x5.4	1810	30
							6.3X6	3160	15
270				6.3X10.5	3160	20	6.3X8	3500	11
							5X6	2690	15
							5X7	3500	11
330							6.3X7	3500	11
							5X7	3500	11
							5X9	3500	11
							6.3x5.4	1810	30
							6.3X6	3390	22
390							6.3X7	3500	9
							6.3X10.5	3190	28
							5X9	3500	11
							6.3X9	3500	8
450							6.3X10.5	3190	28
							8X11.5	4770	12
							5X9	3500	11
470							6.3X6	3390	22
							5X9	3190	28
							6.3X6	3390	22
							6.3X7	4200	9
							6.3X10.5	3190	28
560							8X8	3190	7
	6.3X6	4000	10	6.3X10.5	3160	20	8x11.5	5600	7
	6.3X10.5	3160	20				6.3X7	3500	11
680							6.3X8	4000	10
							6.3X10.5	3190	28
							8X11.5	4770	12
	6.3X10.5	3160	20	6.3X10.5	3160	20	6.3X9	3500	8
	8x11.5	5600	7	8X11.5	5600	7	6.3X10.5	4200	10
750							8x11.5	5600	7
							10X10.5	5600	7
							10X12.5	5600	7
							6.3X9	3190	8
820	6.3X10.5	3160	20	6.3X10.5	3160	20	6.3X9	3500	8
	8x11.5	5600	7	10X12.5	5600	7	6.3X10.5	4200	10
							8x11.5	5600	7
							10X10.5	5050	7
							10x12.5	5600	7
1000							8x8	4770	14
							8x11.5	5600	7
							10X12.5	5600	7
1200							8x11.5	5600	7
							10X10.5	5050	7
1500							10X12.5	5600	7
	8x11.5	5600	7	8x11.5	5600	7	8X11.5	5600	7
	10X12.5	5600	7				10X10.5	5050	8
1800							10X12.5	5600	7
2200							10X12.5	5600	7



CONDUCTIVE POLYMER ALUMINUM SOLID CAPACITORS
Ultra low ESR
Series

■ Dimensions, Rated Ripple Current, Equivalent Series Resistance

Capacitance (uF)	Rated Voltage								
	10V			16V			20V		
	SIZE	RIPPLE	ESR	SIZE	RIPPLE	ESR	SIZE	RIPPLE	ESR
10	5X5.4	1500	45						
22				5X5.4	2070	45			
				5X7	2200	30			
33				6.3X5.4	2200	30			
	5x5.4	1670	45	5X5.4	2070	45			
47				6.3X5.4	2490	24			
				6.3X5.4	1650	35			
68				6.3X7	2610	25			
	6.3X5.4	1810	30	6.3X5.4	1650	35	8X11.5	2980	30
100				6.3X5.4	2490	24	8X11.5	3320	30
	5X7	3500	11	6.3X7	2490	20			
	5X9	3500	11	6.3X8	2820	25			
120				6.3X5.4	2820	25			
				6.3X10.5	4680	10			
150				6.3X10.5	2820	25			
	6.3X5.4	2200	30	6.3X10.5	2820	25			
180				8X8	3150	22			
	6.3X10.5	2820	25	6.3X7	3800	15			
220				6.3X10.5	2820	25			
	8x11.5	5600	7	6.3X10.5	2820	25			
270				8X11.5	4360	16			
	6.3X7	4200	9	6.3X10.5	2820	25			
330				6.3X10.5	2820	25			
	6.3X10.5	2820	25	8X11.5	5000	11			
	6.3X10.5	2820	25	6.3X10.5	3100	20			
390				8X8	5000	11			
				8X11.5	5000	11			
				10X10.5	5050	14			
470				10X10.5	5050	14			
	6.3X9	3500	8	10X12.5	6100	10			
560				8X11.5	5600	7			
	8x11.5	5600	7	10X10.5	5050	14			
680				10X10.5	5050	14			
	6.3X10.5	2820	25	10X12.5	6100	10			
820				10X12.5	6100	10	10X11.5	2720	12
	8x11.5	5600	7	10X12.5	5000	8			
1000				10X12.5	6100	7			
				8X15	5000	10			
1200				8X20	6100	7			
1500				10X12.5	5050	14			
1800									
				10X20	6100	7			

Capacitance (uF)	Rated Voltage								
	25V								
	SIZE	RIPPLE	ESR	SIZE	RIPPLE	ESR	SIZE	RIPPLE	ESR
10	6.3X8	1200	80						
33	6.3X8	1650	35						
	6.3X10.5	1980	35						
47	8X11.5	2980	30						
	6.3X10.5	1980	35						
56	8X11.5	2980	30						
	6.3X10.5	1980	35						
68	8X11.5	2980	30						
	8X11.5	2980	30						
100	8X11.5	2980	30						
	10X10.5	2980	30						
150	10X12.5	4320	30						
	10X12.5	4320	30						

☆ SIZE : φDxL(mm) ☆ tanδ:20°C,120Hz. ☆ Ripple Current:(mA/rms),105°C .100KHz ☆ ESR(mΩ).20°C.100KHz

CONDUCTIVE POLYMER ALUMINUM SOLID CAPACITORS

CP

8 mm height & Ultra low ESR
Series

- Features: 105°C, 3000hrs, 8mm height & Ultra Low ESR
- Recommended Applications: Motherboard, DC/DC Converter, Adapter, SPS, VCR, camcorder, DSC, PDA, HD Drive, MO Drive, DVD Drive, Navigation system, Portable Communication Devices
- Corresponding product to RoHS



Specifications

Item	Characteristics	
Category Temperature Range	-55 ~ +105°C	
Rated Voltage Range	2.5 ~ 25VDC	
Rated Capacitance Range	10 ~ 1200μF	
Capacitance Tolerance	±20% at 120Hz, 20°C	
Surge Voltage	Rated voltage (V) x 1.15	
Leakage Current (MAX) (20°C)	I ≤ 0.2 CV or 300μA whichever is greater (After rated voltage applied for 2 minutes) I = Leakage Current (μA) C = Nominal Capacitance (μF) V = Rated Voltage (V)	
Dissipation Factor (MAX) (tanδ) (120Hz, 20°C)	WV	2.5 ~ 25V
	tanδ	0.08
Low Temperature Stability Impedance Ratio (MAX) (20°C)	WV	
	Z(100KHz)	2.5 ~ 25V
	Z-25°C / Z+20°C	≤ 1.15
	Z-55°C / Z+20°C	≤ 1.25
Endurance	After applying rated voltage for 3000 hours at 105°C, the capacitor shall meet the following requirement.	
	Appearance	No significant damage
	Capacitance Change	Within ±20% of the initial value
	Dissipation Factor	Not more than 150% of the initial specified value
	Equivalent Series Resistance	Not more than 150% of the initial specified value
	Leakage Current	Not more than the initial specified value
	WV	2.5 ~ 6.3V
	Life	3000
		10~25V
		2000
Humidity Test	after subjecting 90 to 95% RH for 1000 hours at 60°C, the capacitors shall meet the requirement as Endurance.	
Surge Voltage Test	After subjecting to 1,000 cycles each consisting of charge with the surge voltage specified at normal temperature for 30 seconds through a protective resistor and discharge for 5 minutes 30 seconds, the capacitors shall meet the requirement as Endurance.	
Failure Rate (MAX)	1% per 1,000 hours (confidence level 60% at 105°C)	

Diagram of Dimensions

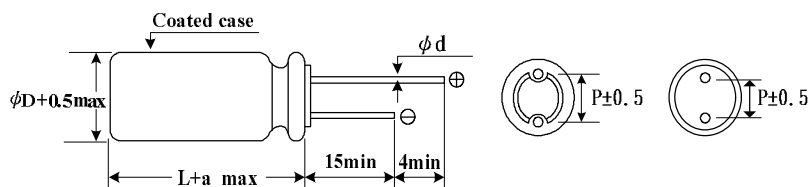

Marking : case with red printing

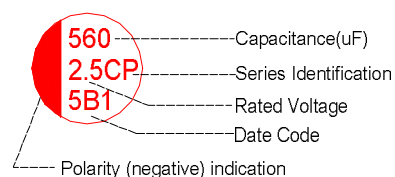

Size code	ψD X L	P	ψd	a
E08	6.3X8	2.5	0.6	1.0
G08	8X8	3.5	0.6	1.5

Multiplier for Ripple Current

Frequency (Hz)	120 ≤ F < 1K	1K ≤ F < 10K	10K ≤ F < 100K	100K ≤ F ≤ 500K
Coefficient	0.05	0.3	0.7	1

CONDUCTIVE POLYMER ALUMINUM SOLID CAPACITORS

CP

8 mm height & Ultra low ESR
Series

■ Dimensions, Rated Ripple Current, Equivalent Series Resistance

Capacitance (uF)	Rated Voltage								
	2.5V			4V			6.3V		
	SIZE	RIPPLE	ESR	SIZE	RIPPLE	ESR	SIZE	RIPPLE	ESR
470							6.3x8	4200	8
							8x8	5600	8
560	6.3x8	4200	6	6.3x8	4200	7	6.3x8	4200	8
	8x8	5600	6	8x8	5600	7	8x8	5600	8
820	6.3x8	4200	6				8x8	5600	8
	8x8	5600	6						
1000							8X8	5600	8
1200	8x8	5600	6	8x8	5600	7			

Capacitance (uF)	Rated Voltage								
	10V			16V			25V		
	SIZE	RIPPLE	ESR	SIZE	RIPPLE	ESR	SIZE	RIPPLE	ESR
10							6.3x8	1200	80
22							6.3x8	1650	35
33							6.3x8	1650	35
							8x8	1980	35
47							8x8	1980	35
56							8x8	1980	35
100				6.3x8	2820	25			
150	6.3x8	2820	25	6.3x8	2820	25			
				8x8	2820	25			
180	6.3x8	2820	25	6.3x8	2820	25			
				8x8	3500	11			
220	6.3x8	2820	25	6.3x8	2820	25			
	8x8	3500	11	8x8	3500	11			
270	6.3x8	2820	25	8x8	3500	11			
				8x8	5000	11			
330	6.3x8	2820	25	8x8	3500	11			
	8x8	3500	11	8x8	5000	11			
470	8x8	3500	11						
560	8x8	5000	10						

☆ SIZE : φDxL(mm) ☆tanδ:20℃,120Hz. ☆Ripple Current:(mA/rms),105℃ .100KHz ☆ ESR(mΩ).20℃.100KHz

CONDUCTIVE POLYMER ALUMINUM SOLID CAPACITORS

CY

Large capacitance Series

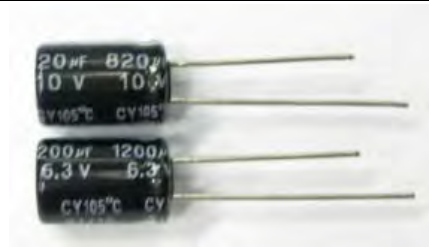

- Features: 105°C, 2000hrs, Low ESR & large capacitance
- Recommended Applications: Used switching regulator applications in computer. Especially for high frequency.

Specifications

Item	Characteristics	
Category Temperature Range	-55 ~ +105°C	
Rated Voltage Range	6.3 ~ 16VDC	
Rated Capacitance Range	150 ~ 1800µF	
Capacitance Tolerance	±20% at 120Hz, 20°C	
Surge Voltage	Rated voltage (V) x 1.15	
Leakage Current (MAX) (20°C)	$I \leq 0.2 CV$ (After rated voltage applied for 2 minutes) I= Leakage Current (µA) C= Nominal Capacitance (µF) V= Rated Voltage (V)	
Dissipation Factor (MAX) (tanδ) (120Hz, 20°C)	WV	6.3 ~ 16V
	tanδ	0.08
Low Temperature Stability Impedance Ratio (MAX) (20°C)	Z(100KHz)	6.3 ~ 16V
	$Z_{-25^\circ C} / Z_{+20^\circ C}$	≤ 1.15
	$Z_{-55^\circ C} / Z_{+20^\circ C}$	≤ 1.25
Endurance	After applying rated voltage for 2000 hours at 105°C, the capacitor shall meet the following requirement.	
	Appearance	No significant damage
	Capacitance Change	Within ±20% of the initial value
	Dissipation Factor	Not more than 150% of the initial specified value
	Equivalent Series Resistance	Not more than 150% of the initial specified value
	Leakage Current	Not more than the initial specified value
Humidity Test	After subjecting 90 to 95% RH for 1000 hours at 60°C, the capacitors shall meet the requirement as Endurance.	
Surge Voltage Test	After subjecting to 1,000 cycles each consisting of charge with the surge voltage specified at normal temperature for 30 seconds through a protective resistor and discharge for 5 minutes 30 seconds, the capacitors shall meet the requirement as Endurance.	
Failure Rate (MAX)	0.5% per 1,000 hours (confidence level 60% at 105°C)	

Diagram of Dimensions

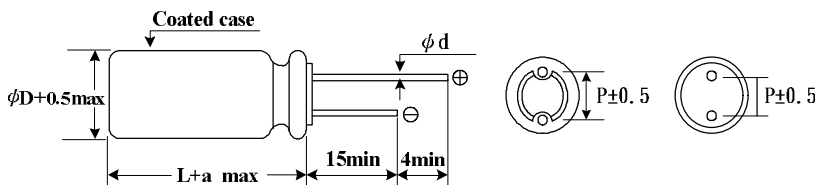

Size code	ψD X L	P	ψd	a
E08	6.3X8	2.5	0.6	1.0
G08	8X8	3.5	0.6	1.5
G1B	8X11.5	3.5	0.6	1.0
H1C	10X12.5	5.0	0.6	1.0

Multiplier for Ripple Current

Frequency (Hz)	120 ≤ f < 1K	1K ≤ f < 10K	10K ≤ f < 100K	100K ≤ f ≤ 500K
Coefficient	0.05	0.3	0.7	1

CONDUCTIVE POLYMER ALUMINUM SOLID CAPACITORS

CY

Large capacitance
Series

- Features: 105°C, 2000hrs, Low ESR & large capacitance
- Recommended Applications: Used switching regulator applications in computer.
Especially for high frequency.

■ Dimensions, Rated Ripple Current, Equivalent Series Resistance

Capacitance (uF)	Rated Voltage								
	6.3V			10V			16V		
	SIZE	RIPPLE	ESR	SIZE	RIPPLE	ESR	SIZE	RIPPLE	ESR
150							6.3X8	2820	30
180							6.3X8	2820	30
220				6.3X8	2820	30	8X8	4500	20
270	5X7	3000	30	6.3X8	2820	30	8X8	4500	20
	6.3X8	3000	30				8X11.5	5000	12
330	6.3X8	3000	30	6.3X8	2820	30	8X8	4500	20
							8X11.5	5000	12
470	6.3X6	3000	30	8X8	4500	20	8X11.5	5000	12
	6.3X8	3000	30						
560	8X8	5000	20	8X8	4500	20	10X12.5	5600	14
				8X11.5	5000	12			
680	8X8	5000	20	8X11.5	5000	12	10X12.5	5600	14
820	6.3X9	3000	30	8X11.5	5000	12	10X12.5	5600	14
	8X8	5000	20						
	8X11.5	5600	12						
1000	8X11.5	5600	12	10X12.5	5600	10			
1200	8X11.5	5600	12	10X12.5	5600	10			
1500	10X12.5	6100	10						
1800	10X12.5	6100	10						

☆ SIZE : φ DxL(mm) ☆ $\tan\delta$: 20°C, 120Hz. ☆ Ripple Current: (mA/rms), 105°C .100KHz ☆ ESR(m Ω), 20°C .100KHz

CONDUCTIVE POLYMER ALUMINUM SOLID CAPACITORS

CZ

Small Size & Low ESR
Series

- Features: 105°C, 2000hrs, Low ESR
- Recommended Applications: Used switching regulator applications in computer. Especially for high frequency.



- Corresponding product to RoHS

Specifications

Item	Characteristics	
Category Temperature Range	-55 ~ +105°C	
Rated Voltage Range	2.5 ~ 16VDC	
Rated Capacitance Range	100 ~ 2200μF	
Capacitance Tolerance	±20% at 120Hz, 20°C	
Surge Voltage	Rated voltage (V) x 1.15	
Leakage Current (MAX) (20°C)	$I \leq 0.2 CV$ or 300μA whichever is greater (After rated voltage applied for 2 minutes)	
	$I =$ Leakage Current (μA) $C =$ Nominal Capacitance (μF) $V =$ Rated Voltage (V)	
Dissipation Factor (MAX) (tanδ) (120Hz, 20°C)	WV	2.5 ~ 16V
	tanδ	0.12
Low Temperature Stability Impedance Ratio (MAX) (20°C)	Z(100KHz)	2.5 ~ 16V
	Z-25°C / Z+20°C	≤ 1.15
	Z-55°C / Z+20°C	≤ 1.25
Endurance	After applying rated voltage for 2000 hours at 105°C, the capacitor shall meet the following requirement.	
	Appearance	No significant damage
	Capacitance Change	Within ±20% of the initial value
	Dissipation Factor	Not more than 150% of the initial specified value
	Equivalent Series Resistance	Not more than 150% of the initial specified value
Humidity Test	after subjecting 90 to 95% RH for 1000 hours at 60°C, the capacitors shall meet the requirement as Endurance.	
	Surge Voltage Test	
Surge Voltage Test	After subjecting to 1,000 cycles each consisting of charge with the surge voltage specified at normal temperature for 30 seconds through a protective resistor and discharge for 5 minutes 30 seconds, the capacitors shall meet the requirement as Endurance.	
	Failure Rate (MAX)	
Failure Rate (MAX)	1% per 1,000 hours (confidence level 60% at 105°C)	

Diagram of Dimensions

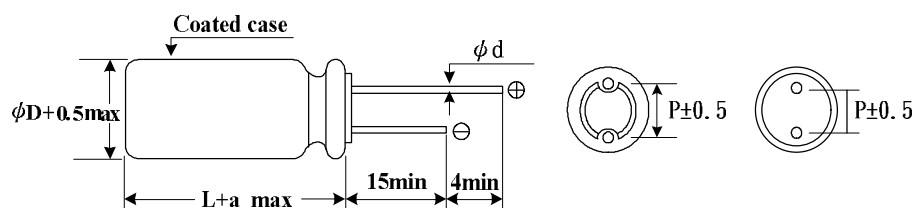

Marking : case with red printing

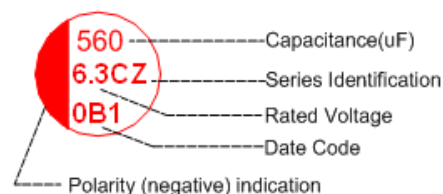

Size code	ψD X L	P	ψd	a
B01	4X5.4	1.5	0.45	1.0
E01	6.3X5.4	2.5	0.45	1.0
E08	6.3X8	2.5	0.6	1.0
G08	8X8	3.5	0.6	1.5
G1B	8X11.5	3.5	0.6	1.0
H1A	10X10.5	5.0	0.6	1.0
H1C	10X12.5	5.0	0.6	1.0

Multiplier for Ripple Current

Frequency (Hz)	120 ≤ F < 1K	1K ≤ F < 10K	10K ≤ F < 100K	100K ≤ F ≤ 500K
Coefficient	0.05	0.3	0.7	1

CONDUCTIVE POLYMER ALUMINUM SOLID CAPACITORS

CZ

Small Size & Low ESR
Series

■ Dimensions, Rated Ripple Current, Equivalent Series Resistance

Capacitance (μ F)	Rated Voltage								
	2.5V			4V			6.3V		
	SIZE	RIPPLE	ESR	SIZE	RIPPLE	ESR	SIZE	RIPPLE	ESR
100							6.3x8	4700	18
220							6.3x5.4	1810	80
270							5X7	3500	35
330							6.3x8	4700	18
470							6.3x8	4700	18
							6.3X10.5	2820	35
560	6.3x8	5000	18	6.3x8	5000	18	6.3x8	4700	18
	8x8	5600	14	8x8	5600	14	8x8	5000	14
680	8x11.5	5600	12				10X10.5	4840	13
820	6.3x8	5000	18	8x8	5600	14	8x11.5	5600	12
	8x8	5600	14	8x11.5	5600	12			
1000	8x11.5	5600	12						
	8x8	5600	14	8x8	5600	14	8x8	5000	14
1200	8x11.5	5600	12	8x11.5	5600	12	8x11.5	5600	12
				10x12.5	5600	10	10x12.5	5600	10
1500	8x11.5	5600	12	8x11.5	5600	12	10x12.5	5600	10
1800	10x12.5	5600	10	10x12.5	5600	10	10x12.5	5600	10
2200	10x12.5	5600	10	10x12.5	5600	10			

Capacitance (μ F)	Rated Voltage								
	10V			16V					
	SIZE	RIPPLE	ESR	SIZE	RIPPLE	ESR			
100				6.3x5.4	1810	80			
150				6.3x8	2820	35			
	6.3X5.4	1810	80	6.3X8	2820	35			
180				6.3X8	2820	35			
220	6.3X8	2820	30	6.3X10.5	2820	35			
	8X11.5	5000	12	8X8	4500	20			
270	10X10.5	4400	18						
	6.3X8	2820	30	8X8	4500	20			
330				8X11.5	5000	12			
				10X10.5	4400	18			
470	6.3X8	2820	30	8X8	4500	20			
	8X8	4500	20	8X11.5	5000	12			
560	8X11.5	5000	12	10X10.5	4400	18			
	8X8	4500	20	10X12.5	5600	14			
680	8X11.5	5000	12						
820	8X11.5	5000	12	10X12.5	5600	14			
1000	10X12.5	5600	10						
1200	10X12.5	5600	10						

☆ SIZE : φ DxL(mm) ☆ $\tan\delta$:20°C,120Hz. ☆ Ripple Current:(mA/rms),105°C .100KHz ☆ ESR(m Ω).20°C.100KHz

CONDUCTIVE POLYMER ALUMINUM SOLID CAPACITORS

CR

High ripple & low ESR
Series

- Features: 105°C, 2000hrs, High Ripple & Low ESR
- Recommended Applications: Motherboard, DC/DC Converter, Adapter, SPS, VCR, Camcorder, DSC, PDA, HD Drive, MO Drive, DVD Drive, Navigation system, Portable Communication Devices
- Corresponding product to RoHS



Specifications

Item	Characteristics	
Category Temperature Range	-55 ~ +105°C	
Rated Voltage Range	2.5 ~ 6.3VDC	
Rated Capacitance Range	270 ~ 2700μF	
Capacitance Tolerance	±20% at 120Hz, 20°C	
Surge Voltage	Rated voltage (V) x 1.15	
Leakage Current (MAX) (20°C)	I ≤ 0.2 CV or 500μA whichever is greater (After rated voltage applied for 2 minutes) I = Leakage Current (μA) C = Nominal Capacitance (μF) V = Rated Voltage (V)	
Dissipation Factor (MAX) (tanδ) (120Hz, 20°C)	WV	2.5 ~ 6.3V
	tanδ	0.10
Low Temperature Stability Impedance Ratio (MAX) (20°C)	Z(100KHz)	2.5 ~ 6.3V
	Z-25°C / Z+20°C	≤ 1.15
	Z-55°C / Z+20°C	≤ 1.25
Endurance	After applying rated voltage for 2000 hours at 105°C, the capacitor shall meet the following requirement.	
	Appearance	No significant damage
	Capacitance Change	Within ±20% of the initial value
	Dissipation Factor	Not more than 150% of the initial specified value
	Equivalent Series Resistance	Not more than 150% of the initial specified value
Humidity Test	after subjecting 90 to 95% RH for 1000 hours at 60°C, the capacitors shall meet the requirement as Endurance.	
	After subjecting to 1,000 cycles each consisting of charge with the surge voltage specified at normal temperature for 30 seconds through a protective resistor and discharge for 5 minutes 30 seconds, the capacitors shall meet the requirement as Endurance.	
Surge Voltage Test	After subjecting to 1,000 cycles each consisting of charge with the surge voltage specified at normal temperature for 30 seconds through a protective resistor and discharge for 5 minutes 30 seconds, the capacitors shall meet the requirement as Endurance.	
Failure Rate (MAX)	1% per 1,000 hours (confidence level 60% at 105°C)	

Diagram of Dimensions

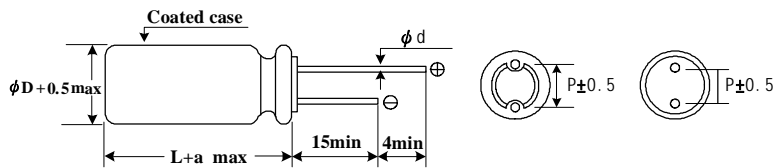

Marking : case with red printing

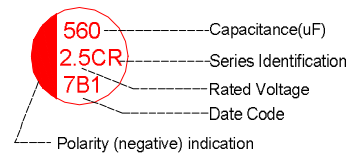

Size code	ψD X L	P	ψd	a
E08	6.3X8	2.5	0.6	1.0
G08	8X8	3.5	0.6	1.5
G1B	8X11.5	3.5	0.6	1.0

Multiplier for Ripple Current

Frequency (Hz)	120 ≤ F < 1K	1K ≤ F < 10K	10K ≤ F < 100K	100K ≤ F ≤ 500K
Coefficient	0.05	0.3	0.7	1

CONDUCTIVE POLYMER ALUMINUM SOLID CAPACITORS

CR

High ripple & low ESR
Series

■ Dimensions, Rated Ripple Current, Equivalent Series Resistance

Capacitance (μ F)	Rated Voltage								
	2.5V			4V			6.3V		
	SIZE	RIPPLE	ESR	SIZE	RIPPLE	ESR	SIZE	RIPPLE	ESR
270							6.3X8	4700	8
330							6.3X8	4700	8
390							6.3X8	4700	8
470							6.3X7	4700	8
							6.3X8	4700	8
							8X8	5700	8
560	6.3X8	5000	7	6.3X8	5000	7	6.3X8	4700	8
	8X8	6100	7	8X8	6100	7	8X8	5700	8
				8X11.5	6100	7			
680	8X8	6100	7	8X8	6100	7	6.3X8	4700	8
	8X11.5	6100	7	8X11.5	6100	7	8x8	5700	8
							8X11.5	5700	7
							6.3X10.5	4800	8
							10X12.5	6100	7
820	6.3X8	5000	7	8X8	6100	7	8X7	5700	8
	8X8	6100	7				8X8	5700	8
	8X11.5	6100	7				8X11.5	5700	7
							10X12.5	6100	7
1000	8X8	6100	7	8X8	6100	7	8X8	5700	8
	8X11.5	6100	7	8X11.5	6100	7	8X11.5	5700	7
				10X12.5	6100	6	10X12.5	6100	7
1200	8X8	6100	7	8X8	6100	7	8X11.5	5700	7
	8X11.5	6100	7	8X11.5	6100	7			
1500	8X11.5	6100	7	8X11.5	6100	7	8X11.5	5700	7
							10X12.5	5560	10
1800				8X11.5	6500	9			
2700	10X12.5	5560	8						

☆ SIZE : ψ DxL(mm) ☆ $\tan\delta$:20°C,120Hz. ☆Ripple Current:(mA/rms),105°C .100KHz ☆ ESR(m Ω),20°C.100KHz

CONDUCTIVE POLYMER ALUMINUM SOLID CAPACITORS

CX

Large capacitance Series

- Features: 105°C, 2000hrs, Low ESR & large capacitance
- Recommended Applications: Used switching regulator applications in computer. Especially for high frequency.



Specifications

Item	Characteristics		
Category Temperature Range	-55 ~ +105°C		
Rated Voltage Range	2.5 ~ 28VDC		
Rated Capacitance Range	33 ~ 820 μ F		
Capacitance Tolerance	\pm 20% at 120Hz, 20°C		
Surge Voltage	2.5V~25V Rated voltage (V) x 1.15, 28V Products is 28V at 25°C		
Leakage Current (MAX) (20°C)	$I \leq 0.2 CV$ (After rated voltage applied for 2 minutes) I = Leakage Current (μ A) C = Nominal Capacitance (μ F) V = Rated Voltage (V)		
Dissipation Factor (MAX) (tan δ) (120Hz, 20°C)	WV	2.5 ~ 6.3V	16 ~ 28V
	tan δ	0.08	0.12
Low Temperature Stability Impedance Ratio (MAX) (20°C)	WV		2.5 ~ 28V
	Z(100KHz)		
	Z-25°C / Z+20°C	≤ 1.15	
	Z-55°C / Z+20°C	≤ 1.25	
Endurance	105°C, 2000hrs, Rated Voltage applied (28V-->25V)※1	After applying rated voltage for 2000 hours at 105°C, the capacitor shall meet the following requirement.	
		Appearance	No significant damage
		Capacitance Change	Within \pm 20% of the initial value
		Dissipation Factor	Not more than 150% of the initial specified value
		Equivalent Series Resistance	Not more than 150% of the initial specified value
	Leakage Current	Not more than the initial specified value	
Humidity Test	After subjecting 90 to 95% RH for 1000 hours at 60°C, the capacitors shall meet the requirement as Endurance.		
Surge Voltage Test	After subjecting to 1,000 cycles each consisting of charge with the surge voltage specified at normal temperature for 30 seconds through a protective resistor and discharge for 5 minutes 30 seconds, the capacitors shall meet the requirement as Endurance.		
Failure Rate (MAX)	0.5% per 1,000 hours (confidence level 60% at 105°C)		

※1Please reduce 0.15V per 1°C from over 85°C for 28V products

Diagram of Dimensions

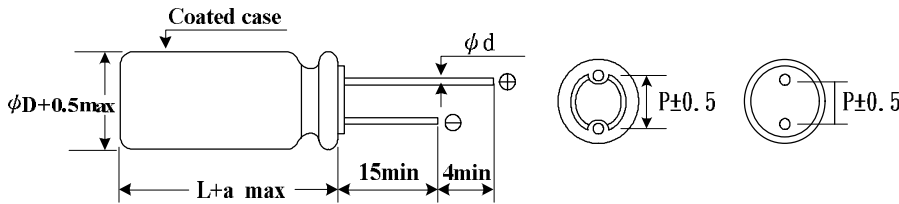

Marking : case with red printing

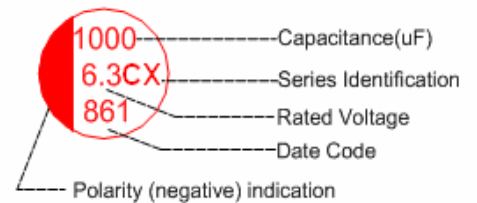

Size code	ϕ D X L	P	ϕ d	a
E08	6.3X8	2.5	0.6	1.0
G08	8X8	3.5	0.6	1.5

Multiplier for Ripple Current

Frequency (Hz)	$120 \leq F < 1K$	$1K \leq F < 10K$	$10K \leq F < 100K$	$100K \leq F \leq 500K$
Coefficient	0.05	0.3	0.7	1

CONDUCTIVE POLYMER ALUMINUM SOLID CAPACITORS

CX

Large capacitance
Series

■ Dimensions, Rated Ripple Current, Equivalent Series Resistance

Capacitance (μ F)	Rated Voltage								
	2.5V			4V			6.3V		
	SIZE	RIPPLE	ESR	SIZE	RIPPLE	ESR	SIZE	RIPPLE	ESR
470							8x8	5700	8
560				6.3x8	5000	7	6.3x8	4700	8
				8x8	6100	7	8x8	5700	8
820	6.3x8	5000	7						
	8x8	6100	7						

Capacitance (μ F)	Rated Voltage								
	16V			28V					
	SIZE	RIPPLE	ESR	SIZE	RIPPLE	ESR	SIZE	RIPPLE	ESR
33				6.3x8	1650	35			
56				8x8	1980	35			
100	6.3x8	2820	25						
270	8x8	5000	11						

☆ SIZE : ϕ DxL(mm) ☆ $\tan \delta$: 20°C, 120Hz. ☆ Ripple Current: (mA/rms), 105°C . 100KHz ☆ ESR(m Ω), 20°C . 100KHz

CONDUCTIVE POLYMER ALUMINUM SOLID CAPACITORS

CF

Large capacitance Series



- Features: 105°C, 2000hrs, Super Low ESR & large capacitance
- Recommended Applications: Motherboard, DC/DC Converter, Adapter, SPS, VCR, camcorder, DSC, PDA, HD Drive, MO Drive, DVD Drive, Navigation system, Portable Communication Devices
- Corresponding product to RoHS

Specifications

Item	Characteristics		
Category Temperature Range	-55 ~ +105°C		
Rated Voltage Range	2.5 ~ 63VDC		
Rated Capacitance Range	10~ 2000 μ F		
Capacitance Tolerance	\pm 20% at 120Hz, 20°C		
Surge Voltage	Rated voltage (V) x 1.15		
Leakage Current (MAX) (20°C)	$I \leq 0.2$ CV or 300 μ A whichever is greater (After rated voltage applied for 2 minutes)		
Dissipation Factor (MAX) (tan δ) (120Hz, 20°C)	WV	2.5 ~ 10V	12 ~ 64V
	tan δ	0.08	0.12
Low Temperature Stability Impedance Ratio (MAX) (20°C)	WV	6.3 ~ 63V	
	Z(100KHz)		
	Z-25°C / Z+20°C	≤ 1.15	
	Z-55°C / Z+20°C	≤ 1.25	
Endurance	After applying rated voltage for 2000 hours at 105°C, the capacitor shall meet the following requirement.		
	Appearance	No significant damage	
	Capacitance Change	Within \pm 20% of the initial value	
	Dissipation Factor	Not more than 150% of the initial specified value	
	Equivalent Series Resistance	Not more than 150% of the initial specified value	
	Leakage Current	Not more than the initial specified value	
Humidity Test	After subjecting 90 to 95% RH for 1000 hours at 60°C, the capacitors shall meet the requirement as Endurance.		
Surge Voltage Test	After subjecting to 1,000 cycles each consisting of charge with the surge voltage specified at normal temperature for 30 seconds through a protective resistor and discharge for 5 minutes 30 seconds, the capacitors shall meet the requirement as Endurance.		
Failure Rate (MAX)	0.5% per 1,000 hours (confidence level 60% at 105°C)		

Diagram of Dimensions

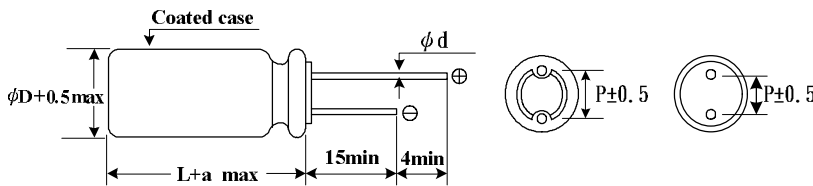

Marking : case with red printing

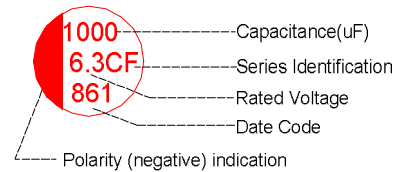

Size code	ϕ D X L	P	ϕ d	a
C09	5X9	2	0.5	1.0
E08	6.3X8	2.5	0.6	1.0
E1A	6.3X10.5	2.5	0.6	1.0
G08	8X8	3.5	0.6	1.5
G10	8X10	3.5	0.6	1.5
G1B	8X11.5	3.5	0.6	1.0
G15	8X15	3.5	0.6	1.5
H1A	10X10.5	5.0	0.6	1.0
H1C	10X12.5	5.0	0.6	1.0
H20	10X20	5.0	0.6	1.5

Multiplier for Ripple Current

Frequency (Hz)	$120 \leq F < 1K$	$1K \leq F < 10K$	$10K \leq F < 100K$	$100K \leq F \leq 500K$
Coefficient	0.05	0.3	0.7	1

CONDUCTIVE POLYMER ALUMINUM SOLID CAPACITORS

CF

Large capacitance Series

■ Dimensions, Rated Ripple Current, Equivalent Series Resistance

Capacitance (uF)	Rated Voltage								
	2.5V			6.3V			10V		
	SIZE	RIPPLE	ESR	SIZE	RIPPLE	ESR	SIZE	RIPPLE	ESR
330				5X9	2400	25			
390				5X9	2400	25			
				6.3X9	2400	25			
560	5X9	4350	10				8X8	3000	10
							10X10.5	5000	7
680				6.3X10.5	2800	28	8X8	3000	10
							8X10	3500	14
							8X11.5	4000	12
820				8X10	4000	7	8X11.5	4000	12
1000				8X8	3000	9	8X11.5	4000	12
				8X11.5	4860	10			
1200				8X10	4000	7	10X12.5	4360	12
				8X11.5	4860	10			
1500				8X11.5	4860	10	10X12.5	4360	12
				10X9	5000	7			
				10X10.5	5000	7			
1800				10X12.5	5000	7			
				10X11.5	5000	7			
2000				10X12.5	5000	7			

Capacitance (uF)	Rated Voltage								
	16V			20V			25V		
	SIZE	RIPPLE	ESR	SIZE	RIPPLE	ESR	SIZE	RIPPLE	ESR
10							5X7	1250	45
22							5X7	350	27
33							6.3X6	1200	35
47							6.3X6	1200	35
56							8X8	1500	30
68							6.3X8	1500	35
							8X8	1500	30
82	5X7	1810	30				6.3X10.5	1500	35
100							6.3X8	1500	35
							6.3X10.5	1500	35
120							6.3X8	1500	35
							6.3X10.5	1500	35
150							8X8	1500	35
							8X10	1980	35
180				10X10.5	3000	30	8X11.5	2280	30
							10X10.5	3000	30
220							10X12.5	3000	30
270	6.3X8	1500	30				8X11.5	2280	30
	6.3X9	3100	20				8X15	2400	20
330	8X8	3000	12	10X12.5	3000	30	8X15	2400	20
							10X12.5	3000	30
390							8X11.5	2280	30
							10X12.5	3000	30
470	8X11.5	4000	12				10X12.5	2050	30
560							10X12.5	2050	30
680							10X12.5	2050	30
820	10X12.5	4000	11						
1000	10X12.5	4000	11						

☆ Size : φDxL(mm) ☆ tanδ:20°C,120Hz. ☆ Ripple Current:(mA/rms),105°C .100KHz ☆ ESR(mΩ).20°C.1

CONDUCTIVE POLYMER ALUMINUM SOLID CAPACITORS

CF

Large capacitance
Series

Dimensions, Rated Ripple Current, Equivalent Series Resistance

Capacitance (uF)	Rated Voltage								
	32V			35V			50V		
	SIZE	RIPPLE	ESR	SIZE	RIPPLE	ESR	SIZE	RIPPLE	ESR
10				5X7	1250	80			
15	6.3X5.4	700	60						
22	6.3X8	990	40	6.3X8	990	40			
				8X8	1200	35			
33				8X8	2000	35	8X8	1300	48
				10X12.5	2400	30			
47	6.3X8	990	40	8X8	1200	35			
56									
68				6.3X8	990	40	10X12.5	2000	45
82	8X8	1200	35						
100	8X8	1200	35						
	8X10	1600	35	8X8	2000	35			
	8X11.5	1800	30	8X11.5	1760	25			
				10X12.5	2400	30			
120	8X11.5	1800	30						
150									
180	10X12.5	2400	30						
220	10X10.5	1800	30	10X12.5	2400	30			
270				10X12.5	2400	30			
330				10X12.5	2400	30			
390									
450				10X20	3000	30			

Capacitance (uF)	Rated Voltage								
	63V								
	SIZE	RIPPLE	ESR						
33	8X8	1100	65						
56	10X12.5	1500	55						

☆ Size : ψ DxL(mm) ☆ $\tan\delta: 20^\circ\text{C}, 120\text{Hz}$. ☆ Ripple Current:(mA/rms), 105°C .100KHz ☆ ESR(m Ω), 20°C .1

CONDUCTIVE POLYMER ALUMINUM SOLID CAPACITORS

CS

Large capacitance & Long Life & High Voltage Series



- Features: 105°C, 2000/5000hrs & Large capacitance & Long Life & High Voltage
- Recommended Applications : LED Driver , LED Power Supply.

■ Corresponding product to RoHS

Specifications

Item	Characteristics	
Category Temperature Range	-55 ~ +105°C	
Rated Voltage Range	20 ~ 50VDC	
Rated Capacitance Range	22 ~ 470μF	
Capacitance Tolerance	±20% at 120Hz , 20°C	
Surge Voltage	Rated voltage (V) x 1.15(at room temperature or at 25°C)	
Leakage Current (MAX) (20°C)	I ≤ 0.2 CV or 300μA whichever is greater (After rated voltage applied for 2 minutes)	
Dissipation Factor (MAX) (tanδ) (120Hz , 20°C)	WV	20 ~ 50V
	tanδ	0.12
Low Temperature Stability Impedance Ratio (MAX) (20°C)	WV	
	Z(100KHz)	25~50V
	Z-25°C / Z+20°C	≤ 1.15
	Z-55°C / Z+20°C	≤ 1.25
Endurance	After applying rated voltage for 2000/5000 hours at 105°C the capacitor shall meet the following requirement.	
	Appearance	No significant damage
	Capacitance Change	Within ±20% of the initial value
	Dissipation Factor	Not more than 150% of the initial specified value
	Equivalent Series Resistance	Not more than 150% of the initial specified value
	Leakage Current	Not more than the initial specified value
Humidity Test	After subjecting 90 to 95% RH for 1000 hours at 60°C. the capacitors shall meet the requirement as Endurance.	
Surge Voltage Test	After subjecting to 1,000 cycles each consisting of charge with the surge voltage specified at normal temperature for 30 seconds through a protective resistor and discharge for 5 minutes 30 seconds, the capacitors shall meet the requirement as Endurance.	
Failure Rate (MAX)	0.5% per 1,000 hours (confidence level 60% at 105°C)	

Diagram of Dimensions

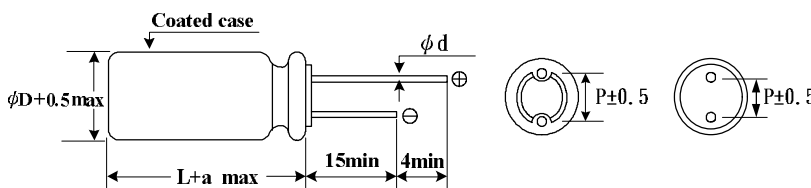

Marking : case with red printing

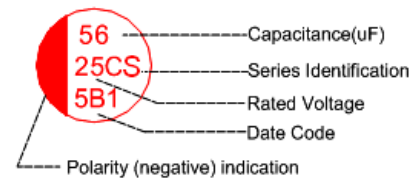

Size code	ψD X L	P	ψd	a
G1B	8X11.5	3.5	0.6	1.0
H1C	10X12.5	5.0	0.6	1.0

Multiplier for Ripple Current

Frequency (Hz)	120 ≤ F < 1K	1K ≤ F < 10K	10K ≤ F < 100K	100K ≤ F ≤ 500K
Coefficient	0.05	0.3	0.7	1

CONDUCTIVE POLYMER ALUMINUM SOLID CAPACITORS

CS

Large capacitance & Long Life & High Voltage Series

■ Dimensions, Rated Ripple Current, Equivalent Series Resistance

Capacitance (uF)	20V			25V		
	SIZE	RIPPLE	ESR	SIZE	RIPPLE	ESR
22				5X9	1250	60
39						
56						
68						
82						
100						
120						
150				8X11.5	1760	25
220				8X11.5	1760	25
270				8X11.5	1760	25
330				10X12.5	2050	25
390	8X11.5	1760	25	10X12.5	2050	25
470				10X12.5	2050	25

Capacitance (uF)	35V			50V		
	SIZE	RIPPLE	ESR	SIZE	RIPPLE	ESR
39	8X8	1500	29			
56	8X8	1500	29	8X11.5	1760	25
68						
82				10X12.5	2050	25
100	8X8	1500	29	10X12.5	2050	25
120	8X11.5	1760	25			
	10X12.5	2050	18			
150	8X11.5	1760	25			
180						
220						
270	10X12.5	2050	25			
330						
390						
470						

☆ Size: ψ DxL(mm) ☆ $\tan\delta$: 20°C, 120Hz. ☆ Ripple Current: (mA/rms), 105°C .100KHz ☆ ESR(mΩ).20°C .100KHz

CONDUCTIVE POLYMER ALUMINUM SOLID CAPACITORS

CH

Long life & Ultra low ESR
Series

- Features: 105°C, 5000hrs, Ultra Low ESR
- Recommended Applications: Motherboard, DC/DC Converter , Adapter , SPS ,VCR , camcorder , DSC , PDA, HD Drive , MO Drive , DVD Drive, Navigation system, Portable Communication Devices
- Corresponding product to RoHS



Specifications

Item	Characteristics	
Category Temperature Range	-55 ~ +105°C	
Rated Voltage Range	2.5 ~ 16VDC	
Rated Capacitance Range	100 ~ 2200μF	
Capacitance Tolerance	±20% at 120Hz , 20°C	
Surge Voltage	Rated voltage (V) x 1.15	
Leakage Current (MAX) (20°C)	I ≤ 0.2 CV or 300μA whichever is greater (After rated voltage applied for 2 minutes) I = Leakage Current (μA) C = Nominal Capacitance (μF) V = Rated Voltage (V)	
Dissipation Factor (MAX) (tanδ) (120Hz ,20°C)	WV	2.5 ~ 16V
	tanδ	0.12
Low Temperature Stability Impedance Ratio (MAX) (20°C)	Z(100KHz)	2.5 ~ 16V
	Z-25°C / Z+20°C	≤ 1.15
	Z-55°C / Z+20°C	≤ 1.25
Endurance	After applying rated voltage for 5000 hours at 105°C , the capacitor shall meet the following requirement.	
	Appearance	No significant damage
	Capacitance Change	Within ±20% of the initial value
	Dissipation Factor	Not more than 150% of the initial specified value
	Equivalent Series Resistance	Not more than 150% of the initial specified value
	Leakage Current	Not more than the initial specified value
Humidity Test	WV	2.5 ~ 16V
	Life	5000
Humidity Test	after subjecting 90 to 95% RH for 1000 hours at 60°C . the capacitors shall meet the requirement as Endurance.	
Surge Voltage Test	After subjecting to 1,000 cycles each consisting of charge with the surge voltage specified at normal temperature for 30 seconds through a protective resistor and discharge for 5 minutes 30 seconds, the capacitors shall meet the requirement as Endurance.	
Failure Rate (MAX)	1% per 1,000 hours (confidence level 60% at 105°C)	

Diagram of Dimensions

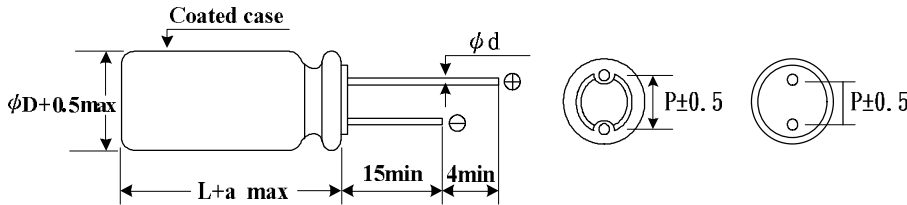

Marking : case with red printing

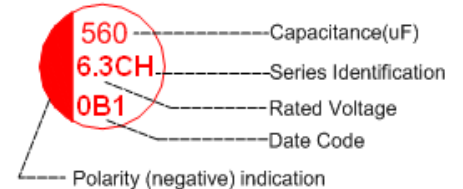

Size code	ψD X L	P	ψd	a
C09	5X9	2.0	0.5	1.0
E01	6.3X5.4	2.5	0.45	1.0
E08	6.3X8	2.5	0.6	1.0
G1B	8X11.5	3.5	0.6	1.0
H1C	10X12.5	5.0	0.6	1.0

Multiplier for Ripple Current

Frequency (Hz)	120 ≤ F < 1K	1K ≤ F < 10K	10K ≤ F < 100K	100K ≤ F ≤ 500K
Coefficient	0.05	0.3	0.7	1

CONDUCTIVE POLYMER ALUMINUM SOLID CAPACITORS

CH

Long life & Ultra low ESR
Series

■ Dimensions, Rated Ripple Current, Equivalent Series Resistance

Capacitance (uF)	Rated Voltage								
	2.5V			4V			6.3V		
	SIZE	RIPPLE	ESR	SIZE	RIPPLE	ESR	SIZE	RIPPLE	ESR
100							6.3X5.4	2320	30
220							6.3X5.4	1700	45
330	6.3X8	3500	7				6.3X8	3500	7
470							6.3x8	3500	7
							8X8	3500	7
560	5X9	4350	7	6.3x8	3500	7	6.3x8	3500	7
	6.3X5.4	3000	16	8X8	6100	7			
	6.3x8	3500	7						
680							6.3X10.5	2400	10
820	6.3x8	3500	7				8X11.5	3500	7
	8X8	3500	7						
860							8X11.5	3500	7
1200							8x11.5	3500	7
1500							10x12.5	3500	7
1800							10x12.5	3500	7

Capacitance (uF)	Rated Voltage								
	10V			16V					
	SIZE	RIPPLE	ESR	SIZE	RIPPLE	ESR			
100				6.3X5.4	2490	24			
				6.3X8	2490	35			
180				6.3X8	2490	25			
220				8X11.5	3000	10			
270				6.3X8	3800	15			
				8X8	3500	10			
				8x11.5	3500	10			
330	8x11.5	3500	10	8X8	3500	10			
470				8x11.5	3500	10			
				10X12.5	6100	9			
560	8X11.5	5000	10	8X11.5	3500	100			
680	8X11.5	3500	10	8X15	3500	11			
820				10x12.5	4000	11			
1000				10X12.5	6000	10			
2200				10X20	6100	8			

☆ Size : ϕDxL(mm) ☆tanδ:20℃,120Hz. ☆Ripple Current:(mA/rms),105℃ .100KHz ☆ ESR(mΩ).20℃.100KHz

CONDUCTIVE POLYMER ALUMINUM SOLID CAPACITORS

CT

125°C 1000hrs / 105°C 5000hrs & Low ESR
Series



- Features: 125°C, 1000hrs & 105°C, 5000hrs, Low ESR
- Recommended Applications: Motherboard, DC/DC Converter, Adapter, SPS, VCR, Camcorder, DSC, PDA, HD Drive, MO Drive, DVD Drive, Navigation system, Portable Communication Devices
- Corresponding product to RoHS

Specifications

Item	Characteristics	
Category Temperature Range	-55 ~ +125°C	
Rated Voltage Range	6.3 ~ 25VDC	
Rated Capacitance Range	10 ~ 1200μF	
Capacitance Tolerance	±20% at 120Hz, 20°C	
Surge Voltage	Rated voltage (V) x 1.15	
Leakage Current (MAX) (20°C)	$I \leq 0.2 CV$ or $300\mu A$ whichever is greater (After rated voltage applied for 2 minutes) Please see the attached characteristics list $I =$ Leakage Current (μA) $C =$ Nominal Capacitance (μF) $V =$ Rated Voltage (V)	
Dissipation Factor (MAX) (tanδ) (120Hz, 20°C)	WV	6.3 ~ 25V
	tanδ	0.12
Low Temperature Stability Impedance Ratio (MAX) (20°C)	WV	6.3 ~ 25V
	Z(100KHz)	≤ 1.15
	Z-25°C / Z+20°C	≤ 1.25
Endurance	After applying rated voltage for 1000 hours at 125°C & 5000 hours at 105°C, the capacitor shall meet the following requirement.	
	Appearance	No significant damage
	Capacitance Change	Within ±20% of the initial value
	Dissipation Factor	Not more than 150% of the initial specified value
	Equivalent Series Resistance	Not more than 150% of the initial specified value
Humidity Test	after subjecting 90 to 95% RH for 1000 hours at 60°C. the capacitors shall meet the requirement as Endurance.	
	Leakage Current	
Surge Voltage Test	After subjecting to 1,000 cycles each consisting of charge with the surge voltage specified at normal temperature for 30 seconds through a protective resistor and discharge for 5 minutes 30 seconds, the capacitors shall meet the requirement as Endurance.	
	Failure Rate (MAX)	
1% per 1,000 hours (confidence level 60% at 105°C)		

Diagram of Dimensions

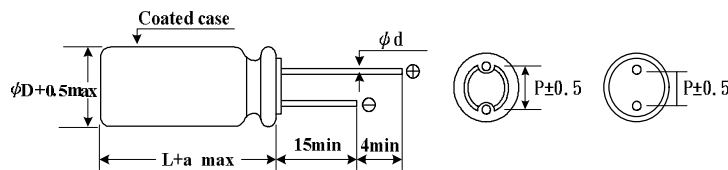

Marking : case with red printing



Size code	ψD X L	P	ψd	a
E08	6.3X8	2.5	0.6	1.0
G08	8X8	3.5	0.6	1.5
G1B	8X11.5	3.5	0.6	1.0
H1C	10X12.5	5	0.6	1.0

Multiplier for Ripple Current

Frequency (Hz)	120 ≤ F < 1K	1K ≤ F < 10K	10K ≤ F < 100K	100K ≤ F ≤ 500K
Coefficient	0.05	0.3	0.7	1

CONDUCTIVE POLYMER ALUMINUM SOLID CAPACITORS

CT

125°C 1000hrs / 105°C 5000hrs & Low ESR
Series

■ Dimensions, Rated Ripple Current, Equivalent Series Resistance

Capacitance (uF)	Rated Voltage									
	6.3V					10V				
	SIZE	RIPPLE		ESR	LC(μA)(max) after 2mins	SIZE	RIPPLE		ESR	LC(μA)(max) after 2mins
Tx : 125°C		To : 105°C	Tx : 125°C				To : 105°C			
180	6.3X8	537	1700	45	300	6.3X8	537	1700	45	360
220	6.3X8	537	1700	45	300	8X8	810	2560	35	440
270	8X8	810	2560	35	340	8X8	810	2560	35	540
330	8X8	810	2560	35	416	8X8	810	2560	35	660
						8X11.5	1250	3950	17	660
470	8X8	810	2560	35	592	10X12.5	1655	5230	13	705
	8X11.5	1332	4210	15	592					
560	8X11.5	1332	4210	15	706	10X12.5	1655	5230	13	840
680	10X12.5	1721	5440	12	643	10X12.5	1655	5230	13	1020
820	10X12.5	1721	5440	12	775					
1000	10X12.5	1721	5440	12	945					

Capacitance (uF)	Rated Voltage									
	16V					20V				
	SIZE	RIPPLE		ESR	LC(μA)(max) after 2mins	SIZE	RIPPLE		ESR	LC(μA)(max) after 2mins
Tx : 125°C		To : 105°C	Tx : 125°C				To : 105°C			
47						6.3X8	458	1450	60	300
56						8X8	598	1890	45	300
68						8X8	598	1890	45	300
82	6.3X8	512	1620	50	300	8X11.5	1050	3320	24	328
100	6.3X8	512	1620	50	320	8X11.5	1050	3320	24	400
120	6.3X1.5	570	1800	45	384	10X12.5	1367	4320	20	480
	8X8	670	2120	40	384					480
150	8X8	670	2120	40	480	10X12.5	1367	4320	20	600
180	8X11.5	1151	3640	20	576					
220	8X11.5	1151	3640	20	704					
270	10X12.5	1493	4720	16	648					
330	8X11.5	1150	3630	20	1056					
	10X12.5	1493	4720	16	792					
470	10X12.5	1493	4720	16	1504					
1200	10X16	1890	6000	12	3840					

Capacitance (uF)	Rated Voltage									
	25V									
	SIZE	RIPPLE		ESR	LC(μA)(max) after 2mins	SIZE	RIPPLE		ESR	LC(μA)(max) after 2mins
Tx : 125°C		To : 105°C	Tx : 125°C				To : 105°C			
10	6.3X8	458	1450	60	300					
22	6.3X8	458	1450	60	300					
33	6.3X8	458	1450	60	300					
47	8X8	598	1890	45	300					
56	8X8	598	1890	45	300					
68	8X11.5	1050	3320	24	340					
82	8X11.5	1050	3320	24	410					
100	6.3X10.5	550	1740	45	500					
	8X11.5	1050	3320	24	500					
	10X12.5	1367	4320	20	500					
120	10X12.5	1367	4320	20	600					
150	10X12.5	1367	4320	20	750					
220	8X11.5	1050	3320	24	1100					
270	8X15	1367	4320	20	1350					
330	8X11.5	840	2650	45	1650					

☆ Tx : Ambient temperature ☆ SIZE : φDxL(mm) ☆ tanδ:20°C,120Hz. ☆ Ripple Current:(mA/rms),105°C .100KHz ☆ ESR(mΩ).20°C .100KHz

SURFACE MOUNT CONDUCTIVE POLYMER ALUMINUM SOLID CAPACITORS

VP

Standard SMD type product

- Features: 105°C, 2000hrs, Standard SMD type product
- Recommended Applications: Motherboard, DC/DC Converter, Adapter, SPS, VCR, camcorder, DSC, PDA, HD Drive, MO Drive, DVD Drive, Navigation system, Portable Communication Devices
- Corresponding product to RoHS



■ Specifications

Item	Characteristics	
Category Temperature Range	-55 ~ +105°C	
Rated Voltage Range	2.5 ~ 25VDC	
Rated Capacitance Range	22 ~ 1500 μF	
Capacitance Tolerance	±20% at 120Hz, 20°C	
Surge Voltage	Rated voltage (V) x 1.15	
Leakage Current (MAX) (20°C) *	Less than or equal to the value of Table. (After rated voltage applied for 2 minutes at 20°C)	
Dissipation Factor (MAX) (tan δ) (120Hz, 20°C)	WV	2.5 ~ 25V
	tan δ	0.12
Low Temperature Stability Impedance Ratio (MAX) (20°C)	Z(100KHz)	2.5 ~ 25V
	Z-25°C / Z+20°C	≤ 1.15
	Z-55°C / Z+20°C	≤ 1.25
Endurance	After applying rated voltage for 2000 hours at 105°C, the capacitor shall meet the following requirement.	
	Appearance	No significant damage
	Capacitance Change	Within ±20% of the initial value
	Dissipation Factor	Not more than 150% of the initial specified value
	Equivalent Series Resistance	Not more than 150% of the initial specified value
	Leakage Current	Not more than the initial specified value
Humidity Test	WV	2.5 ~ 25V
	Life	2000
Humidity Test	after subjecting 90 to 95% RH for 1000 hours at 60°C. the capacitors shall meet the requirement as Endurance.	
Resistance to Soldering Heat *	Capacitance Change	Within ±10% of the initial value
	Dissipation Factor	Not more than 130% of the initial specified value
	Equivalent Series Resistance	Not more than 130% of the initial specified value
	Leakage Current	Not more than the initial specified value

* For any doubt about measured values, measure the leakage current again after the following voltage treatment.
Voltage treatment: Applying DC rated voltage to the capacitors for 2 hours at 105 oC.

■ Diagram of Dimensions

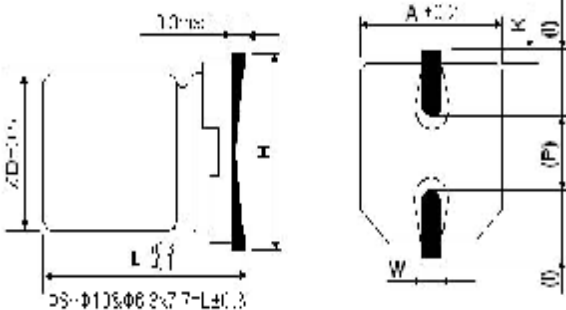

ΦD	L	A	H	I	W	P	K	
5	5.8	5.3	6.5 Max	2.2	0.65±0.15	1.5±0.2	0.35	
								+0.15 -0.2
6.3	5.8	6.6	7.8 Max	2.6	0.65±0.15	1.8±0.2	0.35	
								+0.15 -0.2
6.3	7.7	6.6	7.8 Max	2.6	0.65±0.15	1.8±0.2	0.35	
								+0.15 -0.2
8	6.7	8.3	9.5 Max	3.4	0.65±0.15	2.2±0.2	0.35	
								+0.15 -0.2
8	10.4	8.3	10.0 Max	3.4	0.90±0.2	3.1±0.2	0.70±0.20	
10	10.0	10.3	12.0 Max	3.5	0.90±0.2	4.6±0.2	0.70±0.20	
10	12.2	10.3	12.0 Max	3.5	0.90±0.2	4.6±0.2	0.70±0.20	

■ Multiplier for Ripple Current

Frequency (Hz)	120 ≤ F < 1K	1K ≤ F < 10K	10K ≤ F < 100K	100K ≤ F ≤ 500K
Coefficient	0.05	0.3	0.7	1

SURFACE MOUNT CONDUCTIVE POLYMER ALUMINUM SOLID CAPACITORS

VP

Standard SMD type product

■ Dimensions, Rated Ripple Current, Equivalent Series Resistance

Capacitance (μF)	Rated Voltage							
	2.5V				4V			
	SIZE	RIPPLE	ESR	LC(μA max/2min)	SIZE	RIPPLE	ESR	LC(μA max/2min)
100					6.3x5.8	2450	26	300
120					5x5.8	1490	30	300
150					6.3x5.8	2450	26	300
180	6.3x5.8	2200	25	300				
220	6.3x5.8	2500	25	300				
330					6.3x7.7	2650	25	300
390	6.3x7.7	2720	23	300				
470	6.3x7.7	2720	23	300				
560	8X6.7	2720	23	300	8x10.4	3950	18	448
820					8x10.4	3950	18	656
					10x12.2	5500	10	656
1000	8x10.4	3950	18	500				
1200	10x10.0	4000	12	600	10x10.0	4000	12	960
					10x12.2	5500	10	960
1500	10x10.0	4000	12	750				
	10x12.2	5500	10	750				

Capacitance (μF)	Rated Voltage							
	6.3V				10V			
	SIZE	RIPPLE	ESR	LC(μA max/2min)	SIZE	RIPPLE	ESR	LC(μA max/2min)
22	5X5.8	1380	35	300	5x5.8	1270	40	300
33					5x5.8	1270	40	300
47	5x5.8	1380	35	300	5x5.8	1270	40	300
					6.3x5.8	2250	31	300
56					6.3x5.8	2250	31	300
68	6.3x5.8	2400	27	300				
82	6.3x5.8	2400	27	300				
100	5x5.8	1380	35	300	6.3X5.8	2250	31	300
	6.3x5.8	2400	27	300	6.3X7.7	2560	27	300
120	6.3x5.8	2400	27	300	6.3X7.7	2560	27	300
					8X6.7	2800	27	300
150					6.3x7.7	2560	27	300
220	6.3x5.8	2400	27	300	8X6.7	3220	21	440
	6.3x7.7	2650	25	300				
270	8X6.7	3020	25	300				
	6.3x7.7	2650	25	340				
330	6.3X5.8	2400	270	416				
	6.3x7.7	2650	25	416				
390					8x10.4	3020	22	780
470	6.3X7.7	2650	25	592	10x10.0	3500	14	940
	8X10.4	3610	21	592	10x12.2	5300	12	940
560					10x12.2	5300	12	1120
680	8x10.4	3610	21	857				
	10x10.0	3650	12	857				
	10x12.2	5500	10	857				
820	8X10.4	3610	21	1033				
	10x10.0	3650	12	1033				
	10x12.2	5500	10	1033				
1000	8X10.4	3610	21	1260	10x12.2	4800	13	2000

☆ SIZE : ψDxL(mm) ☆ tanδ:20°C,120Hz. ☆ Ripple Current:(mA/rms),105°C .100KHz ☆ ESR(mΩ),20°C .100KHz

SURFACE MOUNT CONDUCTIVE POLYMER ALUMINUM SOLID CAPACITORS

VP

Standard SMD type product

■ Dimensions, Rated Ripple Current, Equivalent Series Resistance

Capacitance (μF)	Rated Voltage							
	16V				20V			
	SIZE	RIPPLE	ESR	LC(μA max/2min)	SIZE	RIPPLE	ESR	LC(μA max/2min)
22	5x5.8	1210	90	300	6.3X5.8	1650	50	300
33	6.3x5.8	2050	37	300	8X6.7	1900	45	300
39	6.3x5.8	2050	37	300				
47	6.3x5.8	1600	50	300	6.3X7.7	2000	45	300
					8X6.7	1900	45	300
82	6.3x7.7	2420	30	300				
	8X6.7	2700	30	300				
100	6.3x7.7	2420	30	320	8X10.4	3320	24	400
120	6.3X7.7	2420	30	320				
150	8X10.4	3490	23	480				
180	8x10.4	3490	23	576				
220	8x10.4	3490	23	704				
	10x12.2	5050	14	704				
270	8x10.4	3490	23	864				
330	10x10.0	3100	16	1056				
	10x12.2	5050	14	1056				
390	8X10.4	3000	23	1248				
470	10x10.0	3100	16	1504				
	10X12.2	5050	14	1056				
560	10X12.2	5050	14	1792				
680	10X12.2	5050	14	1056				
820	10X12.2	5050	14	2624				

Capacitance (μF)	Rated Voltage							
	25V							
	SIZE	RIPPLE	ESR	LC(μA max/2min)				
27	6.3X5.8	1270	60	300				
33	8X10.4	2500	30	300				
39								
47	6.3X7.7	1800	45	300				
100	8X10.4	3320	24	500				
180								
220	10X12.2	3800	28	1100				
270								
330								
680								

☆ SIZE : ψDxL(mm) ☆tanδ:20°C,120Hz. ☆Ripple Current:(mA/rms),105°C .100KHz ☆ ESR(mΩ).20°C.100KHz

SURFACE MOUNT CONDUCTIVE POLYMER ALUMINUM SOLID CAPACITORS

VB

High capacitance and Super low ESR

- Features: 105°C, 2000hrs, High capacitance and Super low ESR
- Recommended Applications: Motherboard, DC/DC Converter, Adapter, SPS, VCR, camcorder, DSC, PDA, HD Drive, MO Drive, DVD Drive, Navigation system, Portable Communication Devices
- Corresponding product to RoHS



Specifications

Item	Characteristics	
Category Temperature Range	-55 ~ +105°C	
Rated Voltage Range	2.5 ~ 25VDC	
Rated Capacitance Range	33 ~ 1200μF	
Capacitance Tolerance	±20% at 120Hz, 20°C	
Surge Voltage	Rated voltage (V) x 1.15	
Leakage Current (MAX) (20°C)	Less than or equal to the value of Table.(After rated voltage applied for 2 minutes at 20°C)	
Dissipation Factor (MAX) (tanδ) (120Hz, 20°C)	WV	2.5 ~ 25V
	tanδ	0.12
Low Temperature Stability Impedance Ratio (MAX) (20°C)	Z(100KHz)	2.5 ~ 25V
	Z-25°C / Z+20°C	≤ 1.15
	Z-55°C / Z+20°C	≤ 1.25
Endurance	After applying rated voltage for 2000 hours at 105°C, the capacitor shall meet the following requirement.	
	Appearance	No significant damage
	Capacitance Change	Within ±20% of the initial value
	Dissipation Factor	Not more than 150% of the initial specified value
	Equivalent Series Resistance	Not more than 150% of the initial specified value
	Leakage Current	Not more than the initial specified value
Life	WV	2.5 ~ 25V
	Life	2000
Humidity Test	after subjecting 90 to 95% RH for 1000 hours at 60°C. the capacitors shall meet the requirement as Endurance.	
Resistance to Soldering Heat*	Capacitance Change	Within ±10% of the initial value
	Dissipation Factor	Not more than 130% of the initial specified value
	Equivalent Series Resistance	Not more than 130% of the initial specified value
	Leakage Current	Not more than the initial specified value

* For any doubt about measured values, measure the leakage current again after the following voltage treatment.

Voltage treatment: Applying DC rated voltage to the capacitors for 2 hours at 105 oC.

Diagram of Dimensions

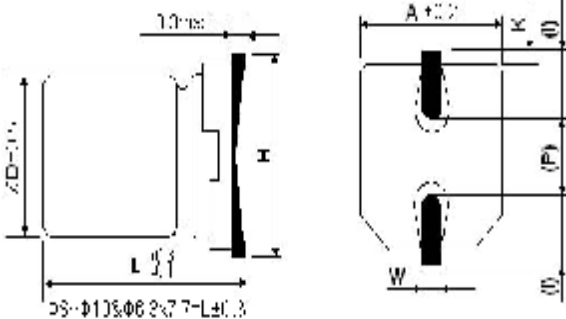

ΦD	L	A	H	I	W	P	K	
6.3	5.8	6.6	7.8 Max	2.6	0.65±0.15	1.8±0.2	0.35	+0.15 -0.2
6.3	7.7	6.6	7.8 Max	2.6	0.65±0.15	1.8±0.2	0.35	+0.15 -0.2
8	6.7	8.3	9.5 Max	3.4	0.65±0.15	2.2±0.2	0.35	+0.15 -0.2
8	10.4	8.3	10.0 Max	3.4	0.90±0.2	3.1±0.2	0.70±0.20	
10	10.0	10.3	12.0 Max	3.5	0.90±0.2	4.6±0.2	0.70±0.20	

Multiplier for Ripple Current

Frequency (Hz)	120 ≤ F < 1K	1K ≤ F < 10K	10K ≤ F < 100K	100K ≤ F ≤ 500K
Coefficient	0.05	0.3	0.7	1

SURFACE MOUNT CONDUCTIVE POLYMER ALUMINUM SOLID CAPACITORS

VB

High capacitance and Super low ESR

■ Dimensions, Rated Ripple Current, Equivalent Series Resistance

Capacitance (μF)	Rated Voltage							
	2.5V				4V			
	SIZE	RIPPLE	ESR	LC(μA max/2min)	SIZE	RIPPLE	ESR	LC(μA max/2min)
220								
270					6.3x5.8	3160	15	300
330	6.3X5.8	3160	15	300	6.3x5.8	3160	15	300
390	6.3x5.8	3160	15	300				
470	6.3X5.8	3160	15	300				
560	6.3x5.8	3500	16	300				
	6.3X7.7	3600	13	300	8X6.7	3220	22	300
	8X6.7	4100	13	300				
820	8X10.4	4210	12	410				

Capacitance (μF)	Rated Voltage							
	6.3V				10V			
	SIZE	RIPPLE	ESR	LC(μA max/2min)	SIZE	RIPPLE	ESR	LC(μA max/2min)
68					5X5.8	1970	30	300
100	6.3X5.8	2500	24	300				
120	6.3x5.8	2500	24	300	6.3x5.8	2600	22	300
150	6.3X5.8	3160	15	300	6.3x7.7	2880	21	300
220	6.3X5.8	3160	15	300	8X6.7	3220	22	540
270					8X6.7	3220	22	540
330	6.3x5.8	3390	17	415	8X10.4	4000	17	660
	6.3X7.7	3470	14	415				
	8X6.7	3950	22	415				
	8X10.4	4210	15					
390	8X6.7	3950	22	491				
	8X10.4	4210	15	491				
470	6.3X7.7	3470	14	592	10x10	5025	12	940
	8X6.7	3220	22	592				
	8X10.4	4210	15	592				
560	8X10.4	4210	15	705				
	10X10	5025	12	705				
820	8X10.4	4210	15	1033				
	10X10	5025	12	1033				
1200	10X10	5025	12	1510				

Capacitance (μF)	Rated Voltage							
	16V				25V			
	SIZE	RIPPLE	ESR	LC(μA max/2min)	SIZE	RIPPLE	ESR	LC(μA max/2min)
33					6.3X7.7	2500	45	300
47					6.3X7.7	2500	45	300
68	6.3x5.8	2440	25	300				
	6.3X7.7	2700	24	300				
100	6.3x5.8	2440	25	300				
	6.3X7.7	2700	24	320				
180	6.3X7.7	3220	22	576				
	8X6.7	3220	25	576				
	8X10.4	3890	18	576				
220	8X10.4	3890	18	704				
270	8X10.4	3890	18	864				
330	10X10	4350	16	1056				
470	10X12.2	6100	10	1504				

☆ SIZE : ψDxL(mm) ☆ tanδ:20°C,120Hz. ☆Ripple Current:(mA/rms),105°C .100KHz ☆ ESR(mΩ).20°C .100KHz

SURFACE MOUNT CONDUCTIVE POLYMER ALUMINUM SOLID CAPACITORS

VS

Long life and Ultra low ESR

- Features: 105°C, 5000hrs, Long life and Ultra low ESR
- Recommended Applications: Motherboard, DC/DC Converter ,
Adapter , SPS ,VCR , camcorder , DSC , PDA,
HD Drive , MO Drive , DVD Drive, Navigation system,
Portable Communication Devices
- Corresponding product to RoHS



■ Specifications

Item	Characteristics	
Category Temperature Range	-55 ~ +105°C	
Rated Voltage Range	4 ~ 20VDC	
Rated Capacitance Range	22 ~ 470µF	
Capacitance Tolerance	±20% at 120Hz , 20°C	
Surge Voltage	Rated voltage (V) x 1.15	
Leakage Current (MAX) (20°C)	Less than or equal to the value of Table.(After rated voltage applied for 2 minutes at 20°C)	
Dissipation Factor (MAX) (tanδ) (120Hz ,20°C)	WV	4 ~ 16V
	tanδ	0.12
Low Temperature Stability Impedance Ratio (MAX) (20°C)	WV	4 ~ 16V
	Z(100KHz)	Z-25°C / Z+20°C
	Z-55°C / Z+20°C	≤ 1.15 ≤ 1.25
Endurance	After applying rated voltage for 5000 hours at 105°C, the capacitor shall meet the following requirement.	
	Appearance	No significant damage
	Capacitance Change	Within ±20% of the initial value
	Dissipation Factor	Not more than 150% of the initial specified value
	Equivalent Series Resistance	Not more than 150% of the initial specified value
	Leakage Current	Not more than the initial specified value
	WV	2.5 ~ 16V
	Life	5000
Humidity Test	after subjecting 90 to 95% RH for 1000 hours at 60°C . the capacitors shall meet the requirement as Endurance.	
Resistance to Soldering Heat *	Capacitance Change	Within ±10% of the initial value
	Dissipation Factor	Not more than 130% of the initial specified value
	Equivalent Series Resistance	Not more than 130% of the initial specified value
	Leakage Current	Not more than the initial specified value

* For any doubt about measured values, measure the leakage current again after the following voltage treatment.

Voltage treatment: Applying DC rated voltage to the capacitors for 2 hours at 105 oC.

■ Diagram of Dimensions

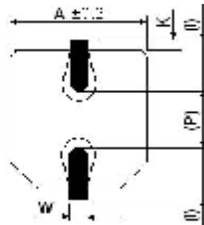
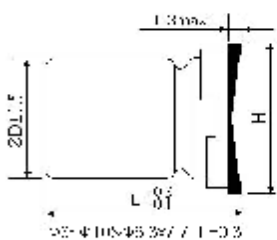

ΦD	L	A	H	I	W	P	K	
6.3	5.8	6.6	7.8 Max	2.6	0.65±0.15	1.8±0.2	0.35	+0.15 -0.2
8	10.4	8.3	10.0 Max	3.4	0.90±0.2	3.1±0.2	0.70±0.20	
10	12.2	10.3	12.0 Max	3.5	0.90±0.2	4.6±0.2	0.70±0.20	

■ Multiplier for Ripple Current

Frequency (Hz)	120 ≤ F < 1K	1K ≤ F < 10K	10K ≤ F < 100K	100K ≤ F ≤ 500K
Coefficient	0.05	0.3	0.7	1

SURFACE MOUNT CONDUCTIVE POLYMER ALUMINUM SOLID CAPACITORS

VS

Long life and Ultra low ESR

■ Dimensions, Rated Ripple Current, Equivalent Series Resistance

Capacitance (μ F)	Rated Voltage							
	4V				6.3V			
	SIZE	RIPPLE	ESR	LC(μ A max/2min)	SIZE	RIPPLE	ESR	LC(μ A max/2min)
100					6.3x5.8	2800	22	300
120					6.3x5.8	2800	22	300
150	6.3x5.8	2570	22	300				
220					6.3x5.8	2800	20	300
					8X6.7	3220	22	300
330	6.3X5.8	2800	20	300	6.3X5.8	2800	20	415
470	6.3X7.7	2800	20	376	10X10	4130	20	592

Capacitance (μ F)	Rated Voltage							
	10V				16V			
	SIZE	RIPPLE	ESR	LC(μ A max/2min)	SIZE	RIPPLE	ESR	LC(μ A max/2min)
22					5X5.8	1060	45	300
39					6.3x5.8	2200	30	300
47	6.3X5.8	2300	27	300				
56	6.3x5.8	2300	27	300				
68	6.3x5.8	2300	27	300	6.3x5.8	2200	30	300
120	6.3x5.8	2300	27	300				
330					10x12.2	3800	14	1056
470	8x10.4	3000	22	940				

Capacitance (μ F)	Rated Voltage							
	20V							
	SIZE	RIPPLE	ESR	LC(μ A max/2min)				
27	6.3X5.8	2450	40	300				
68								
180	10X10	3200	25	720				
470								

☆ SIZE : ψ DxL(mm) ☆ $\tan\delta$:20°C,120Hz. ☆ Ripple Current:(mA/rms),105°C .100KHz ☆ ESR(m Ω).20°C.100KHz

SURFACE MOUNT ALUMINUM ELECTROLYTIC

GV General purpose Series

- Features : 85°C 2000 hours & Low profile vertical chip
- Recommended Applications: Suitable for AV(TV,Video,Audio),Monitor/Computer, Home appliance, OA/HA/Communication
- Corresponding product to RoHS



■ Specifications

Item	Characteristics																																								
Operating Temperature Range	-40 ~ +85°C																																								
Rated Voltage Range (WV)	4 ~ 100VDC																																								
Capacitance Range	1 ~ 1500μF																																								
Capacitance Tolerance	± 20 % at 120Hz , 20°C																																								
Leakage Current (MAX) (20°C)	$I \leq 0.01CV$ or $3(\mu A)$, whichever is greater. (After rated voltage applied for 2 minutes) I= Leakage Current (μA) C= Nominal Capacitance (μF) V= Rated Voltage (V)																																								
Dissipation Factor (MAX) (tanδ) (120Hz ,20°C)	Shown in the table of standard rating																																								
Low Temperature Stability Impedance Ratio (MAX)	<table border="1" style="width: 100%; border-collapse: collapse; text-align: center;"> <thead> <tr> <th style="border: none;">WV</th> <th>4</th> <th>6.3</th> <th>10</th> <th>16</th> <th>25</th> <th>35</th> <th>50</th> <th>63</th> <th>100</th> </tr> </thead> <tbody> <tr> <td style="border: none;">$Z(120HZ)$</td> <td></td> <td></td> <td></td> <td></td> <td></td> <td></td> <td></td> <td></td> <td></td> </tr> <tr> <td style="border: none;">$Z(-25^\circ C) / Z(20^\circ C)$</td> <td>7</td> <td>4</td> <td>3</td> <td>2</td> <td>2</td> <td>2</td> <td>2</td> <td>2</td> <td>2</td> </tr> <tr> <td style="border: none;">$Z(-40^\circ C) / Z(20^\circ C)$</td> <td>15</td> <td>8</td> <td>6</td> <td>4</td> <td>4</td> <td>3</td> <td>3</td> <td>3</td> <td>3</td> </tr> </tbody> </table>	WV	4	6.3	10	16	25	35	50	63	100	$Z(120HZ)$										$Z(-25^\circ C) / Z(20^\circ C)$	7	4	3	2	2	2	2	2	2	$Z(-40^\circ C) / Z(20^\circ C)$	15	8	6	4	4	3	3	3	3
WV	4	6.3	10	16	25	35	50	63	100																																
$Z(120HZ)$																																									
$Z(-25^\circ C) / Z(20^\circ C)$	7	4	3	2	2	2	2	2	2																																
$Z(-40^\circ C) / Z(20^\circ C)$	15	8	6	4	4	3	3	3	3																																
Endurance	<p>After applying rated voltage for 2000hrs at 85°C , the capacitors shall meet the following requirements.</p> <table border="1" style="width: 100%; border-collapse: collapse;"> <tr> <td style="width: 30%;">Capacitance Change</td> <td>Within ±20% of the initial value</td> </tr> <tr> <td>Dissipation Factor</td> <td>Not more than 200% of the specified value</td> </tr> <tr> <td>Leakage Current</td> <td>Not more than the specified value</td> </tr> </table>	Capacitance Change	Within ±20% of the initial value	Dissipation Factor	Not more than 200% of the specified value	Leakage Current	Not more than the specified value																																		
Capacitance Change	Within ±20% of the initial value																																								
Dissipation Factor	Not more than 200% of the specified value																																								
Leakage Current	Not more than the specified value																																								
Shelf Life	After placed at 85°C without voltage applied for 1000 hours, the capacitor shall meet the same requirement as Endurance.																																								

■ Diagram of Dimensions(mm)

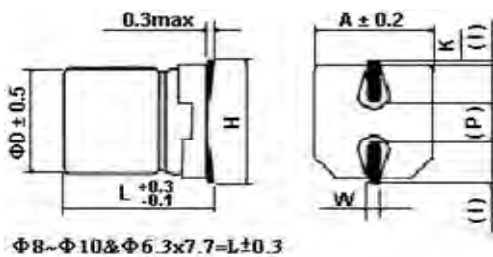

() : Reference size

ψD	L	A	H	I	W	P	K
4.0	5.4	4.3	5.5 Max	1.8	0.65±0.1	1.0±0.2	0.35 +0.15 -0.20
5.0	5.4	5.3	6.5 Max	2.2	0.65±0.1	1.5±0.2	0.35 +0.15 -0.20
6.3	5.4	6.6	7.8 Max	2.6	0.65±0.1	1.8±0.2	0.35 +0.15 -0.20
6.3	7.7	6.6	7.8 Max	2.6	0.65±0.1	1.8±0.2	0.35 +0.15 -0.20
8.0	10.2	8.3	10.0 Max	3.4	0.90±0.2	3.1±0.2	0.70±0.20
10.0	10.2	10.3	12.0 Max	3.5	0.90±0.2	4.6±0.2	0.70±0.20

■ Multiplier for Ripple Current

Frequency coefficient

Frequency (Hz)	60	120	1K	10K
Coefficient	0.80	1.00	1.15	1.25

SURFACE MOUNT ALUMINUM ELECTROLYTIC

GV General purpose Series

■ Dimensions, Max Dissipation Factor, Max Permissible Ripple Current

Capacitance e (μF)	Rated (Surge) Voltage											
	4(5)			6.3(8)			10(13)			16(20)		
	Size	tanδ	Ripple	Size	tanδ	Ripple	Size	tanδ	Ripple	Size	tanδ	Ripple
4.7										4x5.4	0.16	20
10										4x5.4	0.16	28
22				4x5.4	0.26	20	4x5.4	0.30	28	4x5.4	0.26	28
										5x5.4	0.16	39
33	4x5.4	0.35	26	4x5.4	0.26	22	4x5.4	0.30	29	5x5.4	0.26	45
							5x5.4	0.20	43	6.3x5.4	0.16	66
47	4x5.4	0.35	34	4x5.4	0.26	36	5x5.4	0.30	43	5x5.4	0.16	45
				5x5.4	0.26	46				6.3x5.4	0.16	70
100	5x5.4	0.35	61	5x5.4	0.26	47	6.3x5.4	0.26	70	6.3x5.4	0.20	70
				6.3x5.4	0.26	71				6.3x7.7	0.20	85
220	6.3x5.4	0.35	82	6.3x5.4	0.35	74	6.3x7.7	0.26	250	6.3x7.7	0.20	162
				6.3x7.7	0.35	235				8x10.2	0.20	280
330	6.3x5.4	0.35	80	6.3x7.7	0.35	280	8x10.2	0.26	330	8x10.2	0.20	320
										10x10.2	0.20	380
470	6.3x7.7	0.35	200	8x10.2	0.35	380	8x10.2	0.26	390	8x10.2	0.20	350
							10x10.2	0.26	400	10x10.2	0.20	420
1000				8x10.2	0.35	500	10x10.2	0.26	580			
				10x10.2	0.35	700						
1500				10x10.2	0.35	750						

Capacitance e (μF)	Rated (Surge) Voltage								
	25(32)			35(44)			50(63)		
	Size	tanδ	Ripple	Size	tanδ	Ripple	Size	tanδ	Ripple
1							4x5.4	0.12	10
2.2				4x5.4	0.12	8	4x5.4	0.12	16
3.3				4x5.4	0.12	10	4x5.4	0.12	16
4.7	4x5.4	0.14	22	4x5.4	0.12	22	4x5.4	0.14	18
							5x5.4	0.12	23
10	4x5.4	0.20	24	4x5.4	0.16	24	5x5.4	0.14	27
	5x5.4	0.14	28	5x5.4	0.12	30	6.3x5.4	0.12	35
22	5x5.4	0.20	35	5x5.4	0.16	36	6.3x5.4	0.14	40
	6.3x5.4	0.14	55	6.3x5.4	0.12	60	6.3x7.7	0.12	90
33	5x5.4	0.20	42	6.3x5.4	0.16	60	6.3x7.7	0.12	90
	6.3x5.4	0.14	65	6.3x7.7	0.14	130	8x10.2	0.12	120
47	6.3x5.4	0.20	70	6.3x5.4	0.16	70	6.3x7.7	0.12	90
	6.3x7.7	0.16	96	6.3x7.7	0.14	165	8x10.2	0.12	120
100	6.3x7.7	0.16	143	6.3x7.7	0.14	140	8x10.2	0.12	200
	8x10.2	0.16	180	8x10.2	0.14	180	10x10.2	0.12	250
220	8x10.2	0.16	230	8x10.2	0.14	200	10x10.2	0.12	300
	10x10.2	0.16	310	10x10.2	0.14	310			
330	8x10.2	0.16	270	10x10.2	0.14	350			
	10x10.2	0.16	340						
470	10x10.2	0.16	380						

Capacitance e (μF)	Rated (Surge) Voltage					
	63(79)			100(125)		
	Size	tanδ	Ripple	Size	tanδ	Ripple
3.3				6.3x7.7	0.18	50
4.7	6.3x5.4	0.18	20	6.3x7.7	0.18	50
10	6.3x5.4	0.18	20	6.3x7.7	0.18	50
				8x10.2	0.18	55
22	6.3x7.7	0.18	40	8x10.2	0.18	55
	8x10.2	0.18	40	10x10.2	0.18	85
33	8x10.2	0.18	45	10x10.2	0.18	90
47	8x10.2	0.18	45			
100	10x10.2	0.18	60			

☆Size: D \times L (mm). ☆tanδ: 20°C, 120Hz. ☆Ripple Current: 85°C, 120Hz, (mA/rms).

SURFACE MOUNT ALUMINUM ELECTROLYTIC

FV Long Life Series

- Features : 85°C 3000~5000 hours, Longer life than GV, Low profile vertical chip
- Recommended Applications: Suitable for AV(TV,Video,Audio),Monitor/Computer, OA/HA/Communication
- Corresponding product to RoHS



Specifications

Item	Characteristics																																								
Operating Temperature Range	-40 ~ +85°C																																								
Rated Voltage Range (WV)	4 ~ 100VDC																																								
Rated Capacitance Range	1 ~ 1000μF																																								
Capacitance Tolerance	± 20 % at 120Hz , 20°C																																								
Leakage Current (MAX) (20°C)	$I \leq 0.01CV$ or $3(\mu A)$, whichever is greater. (After rated voltage applied for 2 minutes) I= Leakage Current (μA) C= Nominal Capacitance (μF) V= Rated Voltage (V)																																								
Dissipation Factor (MAX) (tanδ) (120Hz ,20°C)	Shown in the table of standard rating																																								
Low Temperature Stability Impedance Ratio (MAX)	<table border="1" style="width: 100%; text-align: center;"> <thead> <tr> <th style="border: none;">WV</th> <th>4</th> <th>6.3</th> <th>10</th> <th>16</th> <th>25</th> <th>35</th> <th>50</th> <th>63</th> <th>100</th> </tr> </thead> <tbody> <tr> <td style="border: none;">$Z(120HZ)$</td> <td></td> <td></td> <td></td> <td></td> <td></td> <td></td> <td></td> <td></td> <td></td> </tr> <tr> <td style="border: none;">$Z(-25^\circ C) / Z(20^\circ C)$</td> <td>7</td> <td>4</td> <td>3</td> <td>2</td> <td>2</td> <td>2</td> <td>2</td> <td>2</td> <td>2</td> </tr> <tr> <td style="border: none;">$Z(-40^\circ C) / Z(20^\circ C)$</td> <td>15</td> <td>8</td> <td>6</td> <td>4</td> <td>4</td> <td>3</td> <td>3</td> <td>3</td> <td>3</td> </tr> </tbody> </table>	WV	4	6.3	10	16	25	35	50	63	100	$Z(120HZ)$										$Z(-25^\circ C) / Z(20^\circ C)$	7	4	3	2	2	2	2	2	2	$Z(-40^\circ C) / Z(20^\circ C)$	15	8	6	4	4	3	3	3	3
WV	4	6.3	10	16	25	35	50	63	100																																
$Z(120HZ)$																																									
$Z(-25^\circ C) / Z(20^\circ C)$	7	4	3	2	2	2	2	2	2																																
$Z(-40^\circ C) / Z(20^\circ C)$	15	8	6	4	4	3	3	3	3																																
Endurance	<p>After applying rated voltage for 3000~5000 hours at 85°C , the capacitors shall meet the following requirements.</p> <table border="1" style="width: 100%; border-collapse: collapse;"> <tr> <td style="width: 30%;">Capacitance Change</td> <td style="width: 40%;">Within ±20% of the initial value</td> <td style="width: 10%;">Case (ψ)</td> <td style="width: 20%;">Life time (hrs)</td> </tr> <tr> <td>Dissipation Factor</td> <td>Not move than 200% of the specified value</td> <td>$\psi D \leq 6.3$</td> <td>3000</td> </tr> <tr> <td>Leakage Current</td> <td>Not more than the specified value</td> <td>$\psi D \geq 8$</td> <td>5000</td> </tr> </table>	Capacitance Change	Within ±20% of the initial value	Case (ψ)	Life time (hrs)	Dissipation Factor	Not move than 200% of the specified value	$\psi D \leq 6.3$	3000	Leakage Current	Not more than the specified value	$\psi D \geq 8$	5000																												
Capacitance Change	Within ±20% of the initial value	Case (ψ)	Life time (hrs)																																						
Dissipation Factor	Not move than 200% of the specified value	$\psi D \leq 6.3$	3000																																						
Leakage Current	Not more than the specified value	$\psi D \geq 8$	5000																																						
Shelf Life	After placed at 85°C without voltage applied for 1000 hours, the capacitor shall meet the same requirement as Endurance.																																								

Diagram of Dimensions(mm)

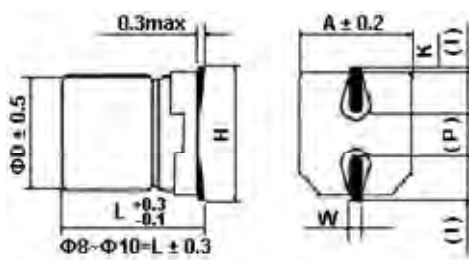

() : Reference size

ψD	L	A	H	I	W	P	K
4.0	5.4	4.3	5.5 Max	1.8	0.65±0.1	1.0±0.2	0.35 ^{+0.15} _{-0.20}
5.0	5.4	5.3	6.5 Max	2.2	0.65±0.1	1.5±0.2	0.35 ^{+0.15} _{-0.20}
6.3	5.4	6.6	7.8 Max	2.6	0.65±0.1	1.8±0.2	0.35 ^{+0.15} _{-0.20}
8.0	6.2	8.3	9.5 Max	3.4	0.65±0.1	2.2±0.2	0.35 ^{+0.15} _{-0.20}
8.0	10.2	8.3	10.0 Max	3.4	0.90±0.2	3.1±0.2	0.70±0.2
10.0	10.2	10.3	12.0 Max	3.5	0.90±0.2	4.6±0.2	0.70±0.2

Multiplier for Ripple Current

Frequency coefficient

Frequency (Hz)	60	120	1K	10K
Coefficient	0.80	1.00	1.15	1.25

SURFACE MOUNT ALUMINUM ELECTROLYTIC

FV Long Life Series

■ Dimensions, Max Dissipation Factor, Max Permissible Ripple Current

Capacitance (μF)	Rated (Surge) Voltage											
	4(5)			6.3(8)			10(13)			16(20)		
	Size	$\tan\delta$	Ripple	Size	$\tan\delta$	Ripple	Size	$\tan\delta$	Ripple	Size	$\tan\delta$	Ripple
4.7										4x5.4	0.16	20
10										4x5.4	0.16	28
22	4x5.4	0.35	19	4x5.4	0.26	20	4x5.4	0.30	28	4x5.4	0.26	27
										5x5.4	0.16	39
33	4x5.4	0.35	26	5x5.4	0.26	22	4x5.4	0.30	29	5x5.4	0.26	45
							5x5.4	0.20	43	6.3x5.4	0.16	66
47	4x5.4	0.35	34	5x5.4	0.26	46	5x5.4	0.30	43	6.3x5.4	0.16	70
100	5x5.4	0.35	61	6.3x5.4	0.26	71	6.3x5.4	0.26	70	6.3x5.4	0.20	70
220	6.3x5.4	0.35	82	6.3x7.7	0.35	250	6.3x7.7	0.26	250	8x10.2	0.20	280
330				6.3x7.7	0.35	300	8x10.2	0.26	330	10x10.2	0.20	380
470				8x10.2	0.35	380	10x10.2	0.26	400	10x10.2	0.20	420
1000				10x10.2	0.35	700	10x10.2	0.26	580			

Capacitance (μF)	Rated (Surge) Voltage								
	25(32)			35(44)			50(63)		
	Size	$\tan\delta$	Ripple	Size	$\tan\delta$	Ripple	Size	$\tan\delta$	Ripple
1							4x5.4	0.12	10
2.2				4x5.4	0.12	8	4x5.4	0.12	16
3.3				4x5.4	0.12	10	4x5.4	0.12	16
4.7	4x5.4	0.14	22	4x5.4	0.12	22	5x5.4	0.12	23
10	4x5.4	0.20	24	4x5.4	0.16	24	6.3x5.4	0.12	35
	5x5.4	0.14	28	5x5.4	0.12	30			
22	6.3x5.4	0.14	55	6.3x5.4	0.12	60	6.3x7.7	0.12	110
33	6.3x5.4	0.14	65	6.3x7.7	0.14	130	8x10.2	0.12	120
47	6.3x5.4	0.20	70	6.3x7.7	0.14	165	10x10.2	0.12	130
	6.3x7.7	0.16	96						
100	8x10.2	0.16	180	10x10.2	0.14	210	10x10.2	0.12	190
220	10x10.2	0.16	310	10x10.2	0.14	310			

Capacitance (μF)	Rated (Surge) Voltage					
	63(79)			100(125)		
	Size	$\tan\delta$	Ripple	Size	$\tan\delta$	Ripple
3.3				8x10.2	0.18	30
4.7	8x10.2	0.18	25	8x10.2	0.18	80
10	8x10.2	0.18	25	8x10.2	0.18	85
22	8x10.2	0.18	45	10x10.2	0.18	85
33	10x10.2	0.18	45	10x10.2	0.18	90
47	10x10.2	0.18	55			

☆Size: D \times L (mm). ☆ $\tan\delta$: 20°C, 120Hz. ☆Ripple Current: 85°C, 120Hz, (mA/rms).

SURFACE MOUNT ALUMINUM ELECTROLYTIC

SV

General Purpose Series

- Features : 105°C 1000 hours , Higher temperature range Than GV, Low profile vertical chip
- Recommended Applications: Suitable for AV(TV,Video,Audio),Monitor/Computer, OA/HA/Communication
- Corresponding product to RoHS



Specifications

Item	Characteristics																																								
Operating Temperature Range	-40 ~ +105°C																																								
Rated Voltage Range (WV)	4 ~ 100VDC																																								
Capacitance Range	1 ~ 1500μF																																								
Capacitance Tolerance	± 20 % at 120Hz , 20°C																																								
Leakage Current (MAX) (20°C)	$I \leq 0.01CV$ or $3(\mu A)$, whichever is greater. (After rated voltage applied for 2 minutes) I= Leakage Current (μA) C= Nominal Capacitance (μF) V= Rated Voltage (V)																																								
Dissipation Factor (MAX) (tanδ) (120Hz ,20°C)	Shown in the table of standard rating																																								
Low Temperature Stability Impedance Ratio (MAX)	<table border="1" style="width: 100%; border-collapse: collapse; text-align: center;"> <thead> <tr> <th style="border: none;">WV</th> <th>4</th> <th>6.3</th> <th>10</th> <th>16</th> <th>25</th> <th>35</th> <th>50</th> <th>63</th> <th>100</th> </tr> </thead> <tbody> <tr> <td style="border: none;">$Z(120HZ)$</td> <td></td> <td></td> <td></td> <td></td> <td></td> <td></td> <td></td> <td></td> <td></td> </tr> <tr> <td style="border: none;">$Z(-25^\circ C) / Z(20^\circ C)$</td> <td>7</td> <td>4</td> <td>3</td> <td>2</td> <td>2</td> <td>2</td> <td>2</td> <td>2</td> <td>2</td> </tr> <tr> <td style="border: none;">$Z(-40^\circ C) / Z(20^\circ C)$</td> <td>15</td> <td>8</td> <td>6</td> <td>4</td> <td>4</td> <td>3</td> <td>3</td> <td>3</td> <td>3</td> </tr> </tbody> </table>	WV	4	6.3	10	16	25	35	50	63	100	$Z(120HZ)$										$Z(-25^\circ C) / Z(20^\circ C)$	7	4	3	2	2	2	2	2	2	$Z(-40^\circ C) / Z(20^\circ C)$	15	8	6	4	4	3	3	3	3
WV	4	6.3	10	16	25	35	50	63	100																																
$Z(120HZ)$																																									
$Z(-25^\circ C) / Z(20^\circ C)$	7	4	3	2	2	2	2	2	2																																
$Z(-40^\circ C) / Z(20^\circ C)$	15	8	6	4	4	3	3	3	3																																
Endurance	<p>After applying rated voltage for 1000hrs at 105°C , the capacitors shall meet the following requirements.</p> <table border="1" style="width: 100%; border-collapse: collapse; text-align: center;"> <tr> <td style="width: 30%;">Capacitance Change</td> <td>Within ±20% of the initial value</td> </tr> <tr> <td>Dissipation Factor</td> <td>Not more than 200% of the specified value</td> </tr> <tr> <td>Leakage Current</td> <td>Not more than the specified value</td> </tr> </table>	Capacitance Change	Within ±20% of the initial value	Dissipation Factor	Not more than 200% of the specified value	Leakage Current	Not more than the specified value																																		
Capacitance Change	Within ±20% of the initial value																																								
Dissipation Factor	Not more than 200% of the specified value																																								
Leakage Current	Not more than the specified value																																								
Shelf Life	After placed at 105°C without voltage applied for 1000 hours, the capacitor shall meet the same requirement as Endurance.																																								

Diagram of Dimensions(mm)

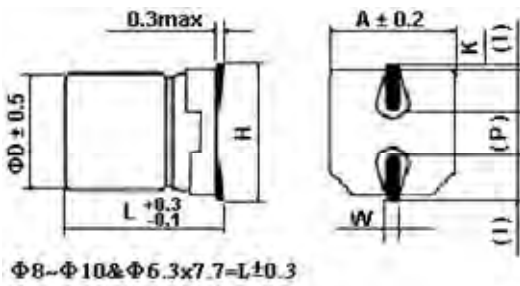

() : Reference size

ψD	L	A	H	I	W	P	K	
4.0	5.4	4.3	5.5 Max	1.8	0.65±0.1	1.0±0.2	0.35	+0.15 -0.20
5.0	5.4	5.3	6.5 Max	2.2	0.65±0.1	1.5±0.2	0.35	+0.15 -0.20
6.3	5.4	6.6	7.8 Max	2.6	0.65±0.1	1.8±0.2	0.35	+0.15 -0.20
6.3	7.7	6.6	7.8 Max	2.6	0.65±0.1	1.8±0.2	0.35	+0.15 -0.20
8.0	10.2	8.3	10.0 Max	3.4	0.90±0.2	3.1±0.2	0.70	±0.2
10.0	10.2	10.3	12.0 Max	3.5	0.90±0.2	4.6±0.2	0.70	±0.2

Multiplier for Ripple Current

Frequency coefficient

Frequency (Hz)	60	120	1K	10K
Coefficient	0.85	1.00	1.15	1.25

SURFACE MOUNT ALUMINUM ELECTROLYTIC

SV General Purpose Series

■ Dimensions, Max Dissipation Factor, Max Permissible Ripple Current

Capacitance (μF)	Rated (Surge) Voltage											
	4(5)			6.3(8)			10(13)			16(20)		
	Size	tanδ	Ripple	Size	tanδ	Ripple	Size	tanδ	Ripple	Size	tanδ	Ripple
4.7										4x5.4	0.16	20
10							4x5.4	0.30	24	4x5.4	0.16	28
22	4x5.4	0.35	20	4x5.4	0.30	29	4x5.4	0.30	36	5x5.4	0.16	39
33	4x5.4	0.35	26	4x5.4	0.3	43	4x5.4	0.30	45	5x5.4	0.20	39
							5x5.4	0.30	46	6.3x5.4	0.20	65
47	4x5.4	0.35	34	4x5.4	0.30	43	5x5.4	0.30	46	5x5.4	0.20	39
				5x5.4	0.30	46	6.3x5.4	0.30	70	6.3x5.4	0.20	70
100	5x5.4	0.35	61	5x5.4	0.35	47	6.3x5.4	0.30	71	6.3x5.4	0.20	70
				6.3x5.4	0.35	71	6.3x7.7	0.30	110	6.3x7.7	0.20	130
220	6.3x5.4	0.35	82	6.3x5.4	0.35	74	6.3x7.7	0.30	115	6.3x7.7	0.20	105
				6.3x7.7	0.35	120	8x10.2	0.26	160	8x10.2	0.20	150
330				6.3x7.7	0.35	175	8x10.2	0.26	200	8x10.2	0.20	170
				8x10.2	0.35	230				10x10.2	0.20	230
470				8x10.2	0.35	300	8x10.2	0.26	230	8x10.2	0.20	230
							10x10.2	0.26	270	10x10.2	0.20	340
680										10x10.2	0.20	380
1000				8x10.2	0.35	300	10x10.2	0.26	390			
				10x10.2	0.35	400						
1500				10x10.2	0.35	480						

Capacitance (μF)	Rated (Surge) Voltage								
	25(32)			35(44)			50(63)		
	Size	tanδ	Ripple	Size	tanδ	Ripple	Size	tanδ	Ripple
1							4x5.4	0.12	10
2.2				4x5.4	0.12	15	4x5.4	0.12	16
3.3				4x5.4	0.12	18	4x5.4	0.12	16
4.7	4x5.4	0.14	22	4x5.4	0.12	22	5x5.4	0.12	23
10	4x5.4	0.14	22	4x5.4	0.12	25	6.3x5.4	0.12	35
	5x5.4	0.14	28	5x5.4	0.12	30			
22	5x5.4	0.14	35	5x5.4	0.14	35	6.3x7.7	0.12	65
	6.3x5.4	0.14	55	6.3x5.4	0.14	60			
33	5x5.4	0.14	45	6.3x5.4	0.14	60	6.3x7.7	0.12	70
	6.3x5.4	0.16	65	6.3x7.7	0.14	84	8x10.2	0.12	91
47	6.3x5.4	0.16	70	6.3x7.7	0.14	84	6.3x7.7	0.12	75
	6.3x7.7	0.16	91	8x10.2	0.14	98	8x10.2	0.12	95
100	6.3x7.7	0.16	95	6.3x7.7	0.14	105	8x10.2	0.12	110
	8x10.2	0.16	130	8x10.2	0.14	120	10x10.2	0.12	145
220	8x10.2	0.16	160	8x10.2	0.14	170	10x10.2	0.12	210
	10x10.2	0.16	273	10x10.2	0.14	240			
330	8x10.2	0.16	180	10x10.2	0.14	250			
	10x10.2	0.16	340						
470	10x10.2	0.16	360						

Capacitance (μF)	Rated (Surge) Voltage					
	63(79)			100(125)		
	Size	tanδ	Ripple	Size	tanδ	Ripple
3.3				8x10.2	0.18	30
4.7	6.3x5.4	0.18	20	8x10.2	0.18	50
10	6.3x5.4	0.18	20	8x10.2	0.18	55
22	8x10.2	0.18	30	10x10.2	0.18	60
33	8x10.2	0.18	30	10x10.2	0.18	65
47	8x10.2	0.18	45	10x10.2	0.18	65
100	10x10.2	0.18	60			

☆Size: D \times L (mm). ☆tanδ: 20°C, 120Hz. ☆Ripple Current: 105°C, 120Hz, (mA/rms).

SURFACE MOUNT ALUMINUM ELECTROLYTIC

DV Long Life Series

- Features : 105°C 2000 hours , Longer life than SV, Low profile ver
- Recommended Applications: Suitable for AV(TV,Video,Audio),Monitor/Computer OA/HA/Communication
- Corresponding product to RoHS



Specifications

Item	Characteristics						
Operating Temperature Range	-40 ~ +105°C			-25~+105°C			
Rated Voltage Range (WV)	6.3 ~ 100VDC			160~450VDC			
Rated Capacitance Range	1 ~ 2200μF						
Capacitance Tolerance	± 20 % at 120Hz , 20°C						
Leakage Current (MAX) (20°C)	I ≤ 0.01CV or 3(μA) , whichever is greater. (After rated voltage applied for 2 minutes) I= Leakage Current (μA) C= Nominal Capacitance (μF) V= Rated Voltage (V)						
Dissipation Factor (MAX) (tanδ) (120Hz ,20°C)	Shown in the table of standard ratings						
Low Temperature Stability Impedance Ratio (MAX)	WV	6.3	10	16	25	35~100	160~45
	Z(120HZ)						0
	Z(-25°C) / Z(20°C)	4	3	2	2	2	4
	Z(-40°C) / Z(20°C)	8	6	4	4	3	-
Endurance	After applying rated voltage for 2000hrs at 105°C , the capacitors shall meet the following requirements.						
	Case (ψ)	ψ4 toψ6.3			ψ8 toψ10		
	Capacitance Change	Within ±25% of the initial value			Within ±20% of the initial value		
	Dissipation Factor	Not more than 200% of the specified value					
Leakage Current	Not more than the specified value						
Shelf Life	After placed at 105°C without voltage applied for 1000 hours, the capacitor shall meet the same requirement as Endurance.						

Diagram of Dimensions(mm)

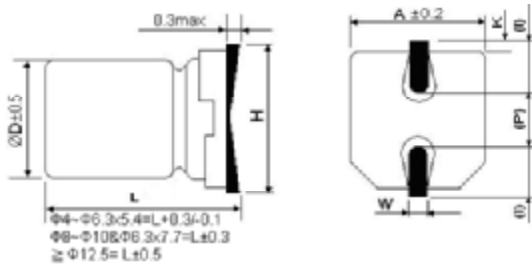

() : Reference size

ψD	L	A	H	I	W	P	K
4.0	5.4	4.3	5.5 Max	1.8	0.65±0.1	1.0±0.2	0.35 +0.15 -0.20
5.0	5.4	5.3	6.5 Max	2.2	0.65±0.1	1.5±0.2	0.35 +0.15 -0.20
6.3	5.4	6.6	7.8 Max	2.6	0.65±0.1	1.8±0.2	0.35 +0.15 -0.20
6.3	7.7	6.6	7.8 Max	2.6	0.65±0.1	1.8±0.2	0.35 +0.15 -0.20
8.0	10.2	8.3	10.0 Max	3.4	0.90±0.2	3.1±0.2	0.70 ±0.20
10.0	10.2	10.3	12.0 Max	3.5	0.90±0.2	4.6±0.2	0.70 ±0.20
12.5	13.5	13	15.0Max	4.8	0.2	4.4±0.2	0.70±0.30
12.5	16.0	13	15.0Max	4.8	0.2	4.4±0.2	0.70±0.30
16.0	16.5	17	19.0Max	6.3	0.2	6.4±0.2	0.70±0.30

Multiplier for Ripple Current

Frequency coefficient

Frequency (Hz)	60	120	1K	10K
Coefficient	0.85	1.00	1.15	1.25

SURFACE MOUNT ALUMINUM ELECTROLYTIC

DV Long Life Series

■ Dimensions, Max Dissipation Factor, Max Permissible Ripple Current

Capacitan ce (μF)	Rated (surge) Voltage																
	6.3(8)			10(13)			16(20)			25(32)			35(44)				
	ψDxL	$\tan\delta$	Rippl	ψDxL	$\tan\delta$	Rippl	ψDxL	$\tan\delta$	Rippl	ψDxL	$\tan\delta$	Rippl	ψDxL	$\tan\delta$	Rippl		
4.7												4x5.4	0.14	22	4x5.4	0.12	22
6.8												4x5.4	0.14	25	4x5.4	0.12	25
10							4x5.4	0.16	28			4x5.4	0.14	25	5x5.4	0.12	30
												5x5.4	0.14	28			
22	4x5.4	0.30	26	4x5.4	0.22	23	4x5.4	0.16	29	5x5.4	0.14	28	6.3x5.4	0.14	60		
							5x5.4	0.16	39	6.3x5.4	0.14	55					
33	4x5.4	0.30	29	5x5.4	0.22	45	5x5.4	0.16	40	6.3x5.4	0.14	65	6.3x7.7	0.14	80		
47	4x5.4	0.30	31	5x5.4	0.22	60	5x5.4	0.16	42	6.3x5.4	0.16	65	6.3x7.7	0.14	100		
	5x5.4	0.30	46	6.3x5.4	0.22	70	6.3x5.4	0.16	70	6.3x7.7	0.16	91	8x10.2	0.14	210		
100	6.3x5.4	0.30	71	6.3x5.4	0.30	71	6.3x5.4	0.20	71	6.3x7.7	0.16	100	8x10.2	0.14	240		
				6.3x7.7	0.30	110	6.3x7.7	0.20	130	8x10.2	0.16	230	10x10.2	0.14	310		
220	6.3x5.4	0.35	80	8x10.2	0.30	120	8x10.2	0.20	150	8x10.2	0.16	270	8x10.2	0.14	260		
	6.3x7.7	0.35	120	8x10.2	0.26	260	10x10.2	0.20	210	10x10.2	0.16	310	10x10.2	0.14	350		
330	6.3x7.7	0.35	140	8x10.2	0.30	290	10x10.2	0.20	230	10x10.2	0.16	340	10x10.2	0.14	370		
	8x10.2	0.35	290														
470	8x10.2	0.35	290	8x10.2	0.30	320	8x10.2	0.20	240	10x10.2	0.16	380	12.5x13	0.22	520		
	10x10.2	0.35	380	10x10.2	0.26	380	10x10.2	0.20	380								
680													12.5x13	0.22	590		
1000	10x10.2	0.35	410	10x10.2	0.26	410	12.5x13	0.34	550	12.5x13	0.26	510	16x16.5	0.22	800		
1500	10x10.2	0.35	460							12.5x16	0.26	590	16x16.5	0.22	1000		
2200	12.5x13	0.35	680	12.5x13	0.30	680	16x16.5	0.34	900	16x16.5	0.26	900					

Capacitan ce (μF)	Rated (surge) Voltage														
	50(63)			63(79)			100(125)			160(200)			200(250)		
	ψDxL	$\tan\delta$	Rippl	ψDxL	$\tan\delta$	Rippl	ψDxL	$\tan\delta$	Rippl	ψDxL	$\tan\delta$	Rippl	ψDxL	$\tan\delta$	Rippl
1	4x5.4	0.12	10												
2.2	4x5.4	0.12	16												
3.3	4x5.4	0.12	16												
4.7	5x5.4	0.12	23												
6.8	5x5.4	0.12	30												
10	5x5.4	0.12	35										12.5x13	0.20	80
	6.3x5.4	0.12	40												
22	6.3x5.4	0.12	42				8x10.2	0.18	100				12.5x16	0.20	110
	6.3x7.7	0.12	65												
33	6.3x7.7	0.12	91	8x10.2	0.18	140	8x10.2	0.18	120	12.5x13	0.20	95	12.5x16	0.20	120
							10x10.2	0.18	150						
47	6.3x7.7	0.12	110	8x10.2	0.18	170	10x10.2	0.18	170	16x16.5	0.20	240	16x16.5	0.20	220
	8x10.2	0.12	210				12.5x13	0.18	250						
100	8x10.2	0.12	240	10x10.2	0.18	340	12.5x13	0.18	300	16x16.5	0.20	250			
	10x10.2	0.12	320												
150				10x10.2	0.18	360									
220	10x10.2	0.12	330	12.5x13	0.14	470									
				12.5x16	0.14	550									
330	12.5x13	0.16	490	16x16.5	0.14	650									
470	12.5x16	0.18	550	16x16.5	0.14	700									
680															
1000	16x16.5	0.18	800												

Capacitan ce (μF)	Rated (surge) Voltage								
	250(300)			400(450)			450(500)		
	ψDxL	$\tan\delta$	Rippl	ψDxL	$\tan\delta$	Rippl	ψDxL	$\tan\delta$	Rippl
3.3	12.5x13	0.20	60	12.5x13	0.25	40	12.5x13	0.25	40
4.7	12.5x13	0.20	65	12.5x13	0.25	45	12.5x13	0.25	45
10	12.5x13	0.20	70	12.5x13	0.25	50	12.5x16	0.25	75
22	12.5x13	0.20	105	16x16.5	0.25	85	16x16.5	0.25	85
33	16x16.5	0.20	180	16x16.5	0.25	85			
47	16x16.5	0.20	220						

☆Size: ψDxL (mm). ☆ $\tan\delta$: 20°C, 120Hz. ☆Ripple Current: 105°C, 120Hz, (mA/rms).

SURFACE MOUNT ALUMINUM ELECTROLYTIC

ZV Low Impedance Series

- Features : 105°C 1000 hours , Wide temperature range, Low profile vertical chip,Low impedance
- Recommended Applications: Suitable for AV(TV,Video,Audio),Monitor/Computer, Battery charger DC/DC converter,SMPS,Noise filter
- Corresponding product to RoHS



Specifications

Item	Characteristics																																
Operating Temperature Range	-55~ +105°C																																
Rated Voltage Range (WV)	4 ~ 50VDC																																
Capacitance Range	1 ~ 1500μF																																
Capacitance Tolerance	± 20 % at 120Hz , 20°C																																
Leakage Current (MAX) (20°C)	$I \leq 0.01CV$ or $3(\mu A)$, whichever is greater. (After rated voltage applied for 2 minutes) I= Leakage Current (μA) C= Nominal Capacitance (μF) V= Rated Voltage (V)																																
Dissipation Factor (MAX) (tanδ) (120Hz ,20°C)	Shown in the table of standard rating																																
Low Temperature Stability Impedance Ratio (MAX)	<table border="1" style="width: 100%; text-align: center;"> <thead> <tr> <th style="border: none;">WV</th> <th>4</th> <th>6.3</th> <th>10</th> <th>16</th> <th>25</th> <th>35</th> <th>50</th> </tr> </thead> <tbody> <tr> <td style="border: none;">$Z(120\text{Hz})$</td> <td></td> <td></td> <td></td> <td></td> <td></td> <td></td> <td></td> </tr> <tr> <td style="border: none;">$Z(-25^\circ\text{C}) / Z(20^\circ\text{C})$</td> <td>4</td> <td>2</td> <td>2</td> <td>2</td> <td>2</td> <td>2</td> <td>2</td> </tr> <tr> <td style="border: none;">$Z(-40^\circ\text{C}) / Z(20^\circ\text{C})$</td> <td>8</td> <td>4</td> <td>4</td> <td>3</td> <td>3</td> <td>3</td> <td>3</td> </tr> </tbody> </table>	WV	4	6.3	10	16	25	35	50	$Z(120\text{Hz})$								$Z(-25^\circ\text{C}) / Z(20^\circ\text{C})$	4	2	2	2	2	2	2	$Z(-40^\circ\text{C}) / Z(20^\circ\text{C})$	8	4	4	3	3	3	3
WV	4	6.3	10	16	25	35	50																										
$Z(120\text{Hz})$																																	
$Z(-25^\circ\text{C}) / Z(20^\circ\text{C})$	4	2	2	2	2	2	2																										
$Z(-40^\circ\text{C}) / Z(20^\circ\text{C})$	8	4	4	3	3	3	3																										
Endurance	<p>After applying rated voltage with rated ripple current for 1000hrs at 105°C , the capacitors shall meet the following requirements.</p> <table border="1" style="width: 100%;"> <tbody> <tr> <td>Capacitance Change</td> <td>Within ±20% of the initial value</td> </tr> <tr> <td>Dissipation Factor</td> <td>Not more than 200% of the specified value</td> </tr> <tr> <td>Leakage Current</td> <td>Not more than the specified value</td> </tr> </tbody> </table>	Capacitance Change	Within ±20% of the initial value	Dissipation Factor	Not more than 200% of the specified value	Leakage Current	Not more than the specified value																										
Capacitance Change	Within ±20% of the initial value																																
Dissipation Factor	Not more than 200% of the specified value																																
Leakage Current	Not more than the specified value																																
Shelf Life	After placed at 105°C without voltage applied for 1000 hours, the capacitor shall meet the same requirement as Endurance.																																

Diagram of Dimensions(mm)

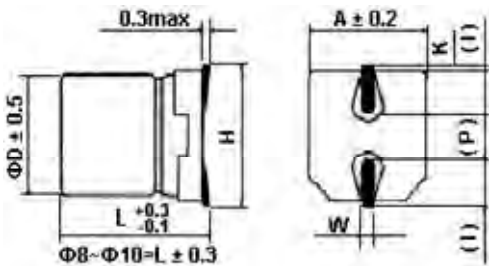

() : Reference size

ψD	L	A	H	I	W	P	K
4.0	5.4	4.3	5.5 Max	1.8	0.65±0.1	1.0±0.2	0.35 +0.15 -0.20
5.0	5.4	5.3	6.5 Max	2.2	0.65±0.1	1.5±0.2	0.35 +0.15 -0.20
6.3	5.4	6.6	7.8 Max	2.6	0.65±0.1	1.8±0.2	0.35 +0.15 -0.20
6.3	7.7	6.6	7.8Max	2.6	0.65±0.1	1.8±0.2	0.35 +0.15 -0.20
8.0	10.2	8.3	10.0 Max	3.4	0.90±0.2	3.1±0.2	0.70 ±0.20
10.0	10.2	10.3	12.0 Max	3.5	0.90±0.2	4.6±0.2	0.70 ±0.20

Multiplier for Ripple Current

Frequency coefficient

Frequency (Hz)	120	1K	10K	100K
Coefficient	0.7	0.8	0.9	1.0

SURFACE MOUNT ALUMINUM ELECTROLYTIC

ZV Low Impedance Series

■ Dimensions, Max Permissible Ripple Current, Max Impedance

Capacitance (μF)	Rated (Surge) Voltage															
	4(5)				6.3(8)				10(13)				16(20)			
	Size	tanδ	Ripple	Z	Size	tanδ	Ripple	Z	Size	tanδ	Ripple	Z	Size	tanδ	Ripple	Z
10	4x5.4	0.35	60	4.0					4x5.4	0.22	60	4.0	4x5.4	0.16	60	4.0
22	4x5.4	0.35	60	4.0	4x5.4	0.26	60	4.0	5x5.4	0.22	95	2.6	5x5.4	0.16	95	2.6
33	4x5.4	0.35	60	4.0	5x5.4	0.26	95	2.6	5x5.4	0.22	95	2.6	5x5.4	0.16	95	2.6
47	4x5.4	0.35	60	4.0	5x5.4	0.26	95	2.6	6.3x5.4	0.22	95	1.3	6.3x5.4	0.16	140	1.3
68	4x5.4	0.35	60	4.0	6.3x5.4	0.26	140	1.3	6.3x5.4	0.22	140	1.3	6.3x7.7	0.20	230	0.8
100	5x5.4	0.35	95	3.0	6.3x5.4	0.26	140	1.3	6.3x5.4	0.22	140	1.3	6.3x7.7	0.20	230	0.8
150	6.3x5.4	0.35	140	2.6	6.3x7.7	0.35	230	0.8	6.3x7.7	0.26	230	0.8	8x10.2	0.20	450	0.5
220	6.3x5.4	0.35	140	2.6	6.3x7.7	0.35	230	0.8	6.3x7.7	0.26	230	0.8	8x10.2	0.20	450	0.5
330					8x10.2	0.35	450	0.5	8x10.2	0.26	450	0.5	10x10.2	0.20	670	0.3
470					10x10.2	0.35	670	0.3	10x10.2	0.26	670	0.3	10x10.2	0.20	670	0.3
1000					10x10.2	0.35	670	0.3	10x10.2	0.26	670	0.3				
1500					10x10.2	0.35	670	0.3								

Capacitance (μF)	Rated (Surge) Voltage											
	25(32)				35(44)				50(63)			
	Size	tanδ	Ripple	Z	Size	tanδ	Ripple	Z	Size	tanδ	Ripple	Z
1					4x5.4	0.12	60	4.0	4x5.4	0.12	60	5.0
2.2					4x5.4	0.12	60	4.0	4x5.4	0.12	60	5.0
3.3					4x5.4	0.12	60	4.0	4x5.4	0.12	60	5.0
4.7	4x5.4	0.14	60	4.0	4x5.4	0.12	60	4.0	5x5.4	0.12	95	4.0
6.8	4x5.4	0.14	60	4.0	5x5.4	0.12	95	2.6	6.3x5.4	0.12	140	2.6
10	5x5.4	0.14	95	2.6	5x5.4	0.12	95	2.6	6.3x5.4	0.12	140	2.6
22	6.3x5.4	0.14	140	1.3	6.3x5.4	0.12	140	1.3	6.3x7.7	0.12	230	1.3
33	6.3x5.4	0.14	140	1.3	6.3x7.7	0.14	230	0.8	8x10.2	0.12	300	1.1
47	6.3x5.4	0.14	140	1.3	6.3x7.7	0.14	230	0.8	10x10.2	0.12	670	0.8
68	8x10.2	0.16	450	0.5	8x10.2	0.14	450	0.5	10x10.2	0.12	670	0.8
100	8x10.2	0.16	450	0.5	10x10.2	0.14	670	0.3	10x10.2	0.12	670	0.8
220	10x10.2	0.16	670	0.3	10x10.2	0.14	670	0.3	10x10.2	0.12	670	0.8
330	10x10.2	0.16	670	0.3	10x10.2	0.14	670	0.3				
470	10x10.2	0.16	670	0.3								

☆Size: Dψx L(mm) ☆Ripple Current: 105°C, 100KHz, (mA/rms) ☆Impedance: 20°C, 100KHz, Z(Ω).

SURFACE MOUNT ALUMINUM ELECTROLYTIC

YV Low Impedance Series

- Features : 105°C 1000~2000 hours , Wide temperature range, Low profile vertical chip, Low impedance
- Recommended Applications: Suitable for AV(TV, Video, Audio), Monitor/Computer, Battery charger, DC/DC converter, SMPS, Noise filter
- Corresponding product to RoHS



■ Specifications

Item	Characteristics																												
Operating Temperature Range	-55 ~ +105°C																												
Rated Voltage Range (WV)	6.3 ~ 50VDC																												
Capacitance Range	1 ~ 1500μF																												
Capacitance Tolerance	± 20 % at 120Hz , 20°C																												
Leakage Current (MAX) (20°C)	$I \leq 0.01CV$ or $3(\mu A)$, whichever is greater. (After rated voltage applied for 2 minutes) $I =$ Leakage Current (μA) $C =$ Nominal Capacitance (μF) $V =$ Rated Voltage (V)																												
Dissipation Factor (MAX) (tanδ) (120Hz , 20°C)	Shown in the table of standard rating																												
Low Temperature Stability Impedance Ratio (MAX)	<table border="1" style="width: 100%; text-align: center;"> <thead> <tr> <th style="border: none;">WV</th> <th>6.3</th> <th>10</th> <th>16</th> <th>25</th> <th>35</th> <th>50</th> </tr> </thead> <tbody> <tr> <td style="border: none;">$Z(120HZ)$</td> <td></td> <td></td> <td></td> <td></td> <td></td> <td></td> </tr> <tr> <td style="border: none;">$Z(-25^\circ C) / Z(20^\circ C)$</td> <td>2</td> <td>2</td> <td>2</td> <td>2</td> <td>2</td> <td>2</td> </tr> <tr> <td style="border: none;">$Z(-40^\circ C) / Z(20^\circ C)$</td> <td>4</td> <td>4</td> <td>3</td> <td>3</td> <td>3</td> <td>3</td> </tr> </tbody> </table>	WV	6.3	10	16	25	35	50	$Z(120HZ)$							$Z(-25^\circ C) / Z(20^\circ C)$	2	2	2	2	2	2	$Z(-40^\circ C) / Z(20^\circ C)$	4	4	3	3	3	3
WV	6.3	10	16	25	35	50																							
$Z(120HZ)$																													
$Z(-25^\circ C) / Z(20^\circ C)$	2	2	2	2	2	2																							
$Z(-40^\circ C) / Z(20^\circ C)$	4	4	3	3	3	3																							
Endurance	<p>After applying rated voltage with rated ripple current for 1000~2000hrs at 105°C , the capacitors shall meet the following requirements.</p> <table border="1" style="width: 100%; text-align: center;"> <tbody> <tr> <td>Capacitance Change</td> <td colspan="2">6.3VF Within ±30% of the initial value, 10-50VF Within ±20% of the initial value</td> </tr> <tr> <td>Dissipation Factor</td> <td colspan="2">Not more than 200% of the specified value</td> </tr> <tr> <td>Leakage Current</td> <td colspan="2">Not more than the specified value</td> </tr> <tr> <td>DΦ</td> <td>4x5.4~6.3x7.7</td> <td>8x10.2~10x10.2</td> </tr> <tr> <td>Life</td> <td>1000hrs</td> <td>2000hrs</td> </tr> </tbody> </table>	Capacitance Change	6.3VF Within ±30% of the initial value, 10-50VF Within ±20% of the initial value		Dissipation Factor	Not more than 200% of the specified value		Leakage Current	Not more than the specified value		DΦ	4x5.4~6.3x7.7	8x10.2~10x10.2	Life	1000hrs	2000hrs													
Capacitance Change	6.3VF Within ±30% of the initial value, 10-50VF Within ±20% of the initial value																												
Dissipation Factor	Not more than 200% of the specified value																												
Leakage Current	Not more than the specified value																												
DΦ	4x5.4~6.3x7.7	8x10.2~10x10.2																											
Life	1000hrs	2000hrs																											
Shelf Life	After placed at 105°C without voltage applied for 1000 hours, the capacitor shall meet the same requirement as Endurance.																												

■ Diagram of Dimensions(mm)



() : Reference size

ψD	L	A	H	I	W	P	K	
4.0	5.4	4.3	5.5 Max	1.8	0.65±0.1	1.0±0.2	0.35	+0.15 -0.20
5.0	5.4	5.3	6.5 Max	2.2	0.65±0.1	1.5±0.2	0.35	+0.15 -0.20
6.3	5.4	6.6	7.8 Max	2.6	0.65±0.1	1.8±0.2	0.35	+0.15 -0.20
8.0	6.2	8.3	9.5 Max	3.4	0.65±0.1	2.2±0.2	0.35	+0.15 -0.20
8.0	10.2	8.3	10.0 Max	3.4	0.90±0.2	3.1±0.2	0.70±0.20	
10.0	10.2	10.3	12.0 Max	3.5	0.90±0.2	4.6±0.2	0.70±0.20	

■ Multiplier for Ripple Current

Frequency coefficient

Frequency (Hz)	120	1K	10K	100K
Coefficient	0.7	0.8	0.9	1.0

SURFACE MOUNT ALUMINUM ELECTROLYTIC



Low Impedance
Series

■ Dimensions, Max Permissible Ripple Current, Max Impedance

Capacitance (μ F)	Rated (Surge) Voltage											
	6.3(8)				10(13)				16(20)			
	Size	$\tan\delta$	Ripple	Z	Size	$\tan\delta$	Ripple	Z	Size	$\tan\delta$	Ripple	Z
10									4x5.4	0.16	60	3.0
22	4x5.4	0.26	60	3.0	5x5.4	0.22	95	1.8	5x5.4	0.16	95	1.8
33	5x5.4	0.26	95	1.8	5x5.4	0.22	95	1.8	4	0.16	140	1.0
47	5x5.4	0.26	95	1.8	4	0.22	140	1.0	4	0.16	140	1.0
100	4	0.26	140	1.0	4	0.22	140	1.0	4	0.16	140	1.0
220	4	0.26	140	1.0	7	0.22	280	0.34	7	0.16	280	0.34
330	7	0.26	280	0.34	8x10.2	0.26	450	0.3	8x10.2	0.20	450	0.3
470	8x10.2	0.35	450	0.3	8x10.2	0.26	450	0.3	8x10.2	0.20	450	0.3
680	8x10.2	0.35	450	0.3	2	0.26	670	0.15	2	0.20	670	0.15
1000	8x10.2	0.35	450	0.3	2	0.26	670	0.15				
1500	2	0.35	670	0.15								

Capacitance (μ F)	Rated (Surge) Voltage											
	25(32)				35(44)				50(63)			
	Size	$\tan\delta$	Ripple	Z	Size	$\tan\delta$	Ripple	Z	Size	$\tan\delta$	Ripple	Z
1									4x5.4	0.12	30	5.0
2.2									4x5.4	0.12	30	5.0
3.3									4x5.4	0.12	30	5.0
4.7					4x5.4	0.12	60	3.0	5x5.4	0.12	50	3.0
10	5x5.4	0.14	95	1.8	5x5.4	0.12	95	1.8	4	0.12	70	2.0
22	4	0.14	140	1.0	4	0.12	140	1.0	4	0.12	70	2.0
33	4	0.14	140	1.0	4	0.12	140	1.0	7	0.12	170	1.3
47	4	0.14	140	1.0	4	0.12	140	1.0	7	0.12	170	1.3
68	7	0.14	280	0.34	7	0.12	280	0.34	8x10.2	0.12	300	0.6
100	7	0.14	280	0.34	8x10.2	0.14	450	0.3	8x10.2	0.12	300	0.6
220	8x10.2	0.16	450	0.3	8x10.2	0.14	450	0.3	2	0.12	500	0.34
330	8x10.2	0.16	450	0.3	2	0.14	670	0.15				
470	2	0.16	670	0.15								

☆Size: D \times L (mm) ☆Ripple Current: 105°C, 100KHz, (mA/rms) ☆Impedance: 20°C, 100KHz, Z(Ω).

SURFACE MOUNT ALUMINUM ELECTROLYTIC

EV Ultra Low Impedance Series

■ Features : 105°C 2000 hours , Low profile vertical chip, Ultra low impedance

■ Recommended Applications: AV(TV,Video,Audio) ,Monitor/Computer, OA/HA/Communication ,SMPS

■ Corresponding product to RoHS



Specifications

Item	Characteristics																					
Operating Temperature Range	-55 ~ +105°C																					
Rated Voltage Range (WV)	6.3 ~ 50VDC																					
Capacitance Range	4.7 ~ 1500μF																					
Capacitance Tolerance	± 20 % at 120Hz , 20°C																					
Leakage Current (MAX) (20°C)	$I \leq 0.01CV$ or $3\mu A$ whichever is greater (After rated voltage applied for 2 minutes) I = Leakage Current (μA) C = Nominal Capacitance (μF) V = Rated Voltage (V)																					
Dissipation Factor (MAX) (tanδ) (120Hz, 20°C)	Shown in the table of standard rating																					
Low Temperature Stability Impedance Ratio (MAX)	<table border="1" style="width: 100%; text-align: center;"> <thead> <tr> <th style="text-align: left;">WV \ Z(120HZ)</th> <th>6.3</th> <th>10</th> <th>16</th> <th>25</th> <th>35</th> <th>50</th> </tr> </thead> <tbody> <tr> <td>Z(-25°C) / Z(20°C)</td> <td>2</td> <td>2</td> <td>2</td> <td>2</td> <td>2</td> <td>2</td> </tr> <tr> <td>Z(-40°C) / Z(20°C)</td> <td>3</td> <td>3</td> <td>3</td> <td>3</td> <td>3</td> <td>3</td> </tr> </tbody> </table>	WV \ Z(120HZ)	6.3	10	16	25	35	50	Z(-25°C) / Z(20°C)	2	2	2	2	2	2	Z(-40°C) / Z(20°C)	3	3	3	3	3	3
WV \ Z(120HZ)	6.3	10	16	25	35	50																
Z(-25°C) / Z(20°C)	2	2	2	2	2	2																
Z(-40°C) / Z(20°C)	3	3	3	3	3	3																
Endurance	<p>After applying rated voltage with rated ripple current for 2000 hours at 105°C, the capacitor shall meet the following requirement.</p> <table border="1" style="width: 100%;"> <tbody> <tr> <td>Capacitance Change</td> <td>Within ±30% of the initial value</td> </tr> <tr> <td>Dissipation Factor</td> <td>Not more than 200% of the specified value</td> </tr> <tr> <td>Leakage Current</td> <td>Not more than the specified value</td> </tr> </tbody> </table>	Capacitance Change	Within ±30% of the initial value	Dissipation Factor	Not more than 200% of the specified value	Leakage Current	Not more than the specified value															
Capacitance Change	Within ±30% of the initial value																					
Dissipation Factor	Not more than 200% of the specified value																					
Leakage Current	Not more than the specified value																					
Shelf Life	After placed at 105°C without voltage applied for 1000 hours, the capacitor shall meet the same requirement as Endurance.																					

Diagram of Dimensions(mm)

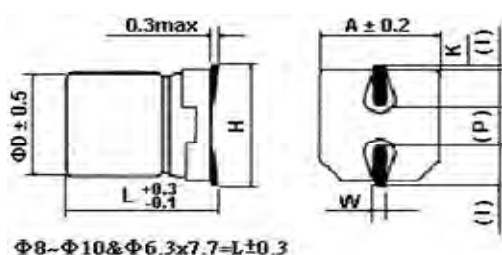

ψD	L	A	H	I	W	P	K	
4.0	5.4	4.3	5.5 Max	1.8	0.65±0.1	1.0±0.2	0.35	+0.15 -0.20
5.0	5.4	5.3	6.5 Max	2.2	0.65±0.1	1.5±0.2	0.35	+0.15 -0.20
6.3	5.4	6.6	7.8 Max	2.6	0.65±0.1	1.8±0.2	0.35	+0.15 -0.20
6.3	7.7	6.6	7.8 Max	2.6	0.65±0.1	1.8±0.2	0.35	+0.15 -0.20
8.0	10.2	8.3	10.0 Max	3.4	0.90±0.2	3.1±0.2	0.70	±0.2
10.0	10.2	10.3	12.0 Max	3.5	0.90±0.2	4.6±0.2	0.70	±0.2

Multiplier for Ripple Current

Frequency coefficient

Frequency (Hz)	120	1K	10K	100K
Coefficient	0.70	0.80	0.90	1.00

SURFACE MOUNT ALUMINUM ELECTROLYTIC

EV Ultra Low Impedance Series

■ Case Size / tanδ / Max Ripple Current / Impedance

Capacitance (μF)	Rated (Surge) Voltage											
	6.3(8)				10(13)				16(20)			
	ψDxL	tanδ	RC	Z	ψDxL	tanδ	RC	Z	ψDxL	tanδ	RC	Z
22	4x5.4	0.26	90	1.93	4x5.4	0.19	90	1.93	4x5.4	0.16	90	1.93
									5x5.4	0.16	160	1.00
33	4x5.4	0.26	90	1.93	4x5.4	0.19	90	1.93	5x5.4	0.16	160	1.00
					5x5.4	0.19	160	1.00				
47	4x5.4	0.26	90	1.93	6.3x5.4	0.19	190	0.52	5x5.4	0.16	160	1.00
	5x5.4	0.26	160	1.00					6.3x5.4	0.16	240	0.52
100	5x5.4	0.26	160	1.00	6.3x5.4	0.19	190	0.52	6.3x5.4	0.16	240	0.52
	6.3x5.4	0.26	240	0.52								
150	6.3x7.7	0.26	240	0.30	6.3x7.7	0.19	240	0.34	6.3x7.7	0.16	280	0.34
220	6.3x7.7	0.26	240	0.30	6.3x7.7	0.19	280	0.34	6.3x7.7	0.16	280	0.34
									8x10.2	0.16	370	0.22
330	6.3x7.7	0.26	280	0.34	8x10.2	0.19	600	0.16	8x10.2	0.16	600	0.16
470	8x10.2	0.26	600	0.16	8x10.2	0.19	600	0.16	8x10.2	0.16	600	0.16
680	8x10.2	0.26	600	0.16	10x10.2	0.19	600	0.12	10x10.2	0.16	850	0.08
1000	8x10.2	0.26	600	0.16	10x10.2	0.19	850	0.08				
1500	10x10.2	0.26	850	0.08								

Capacitance (μF)	Rated (Surge) Voltage											
	25(32)				35(44)				50(63)			
	ψDxL	tanδ	RC	Z	ψDxL	tanδ	RC	Z	ψDxL	tanδ	RC	Z
4.7					4x5.4	0.12	90	1.93				
10	4x5.4	0.14	90	1.93	4x5.4	0.12	90	1.93				
					5x5.4	0.12	160	1.00	6.3x5.4	0.12	70	2.60
22	5x5.4	0.14	160	1.00	5x5.4	0.12	160	1.00	6.3x5.4	0.12	70	2.00
33	5x5.4	0.14	160	1.00	6.3x5.4	0.12	240	0.52	6.3x7.7	0.12	170	0.8
	6.3x5.4	0.14	240	0.52								
47	6.3x5.4	0.14	240	0.52	6.3x5.4	0.12	240	0.52	8x6.2	0.12	170	1.3
68	6.3x5.4	0.14	240	0.52	6.3x7.7	0.12	280	0.34				
100	6.3x7.7	0.14	280	0.34	6.3x7.7	0.12	280	0.34				
					8x10.2	0.12	600	0.16	8x10.2	0.12	300	0.4
150	8x10.2	0.14	600	0.16	8x10.2	0.12	600	0.16				
220	8x10.2	0.14	600	0.16	8x10.2	0.12	600	0.16	10x10.2	0.12	500	0.3
330	8x10.2	0.14	600	0.16	10x10.2	0.12	850	0.08				
470	10x10.2	0.14	850	0.08								

☆CASE SIZE : ψDxL(mm) 、 MAX DISSIPATION FACTOR : tanδ / 120Hz,20℃.
 MAX PERMISSIBLE RIPPLE CURRENT : RC(mArms) / 100KHz,105℃.
 MAX IMPEDANCE : Z(Ω) / 100KHz,20℃.

SURFACE MOUNT ALUMINUM ELECTROLYTIC

JV Ultra Low Impedance Series



■ Features : 105°C 2000 hours , Low profile vertical chip, Ultra low impedance

■ Recommended Applications: AV(TV,Video,Audio) ,Monitor/Computer, OA/HA/Communication ,SMPS

■ Corresponding product to RoHS

■ Specifications

Item	Characteristics																		
Operating Temperature Range	-55 ~ +105°C																		
Rated Voltage Range (WV)	6.3 ~ 35VDC																		
Capacitance Range	10~ 1800μF																		
Capacitance Tolerance	± 20 % at 120Hz , 20°C																		
Leakage Current (MAX) (20°C)	$I \leq 0.01CV$ or $3\mu A$ whichever is greater(After rated voltage applied for 2 minutes) I = Leakage Current (μA) C = Nominal Capacitance (μF) V = Rated Voltage (V)																		
Dissipation Factor (MAX) (tanδ) (120Hz ,20°C)	Shown in the table of standard rating																		
Low Temperature Stability Impedance Ratio (MAX)	<table border="1" style="width: 100%; text-align: center;"> <thead> <tr> <th style="text-align: left;">WV \ Z(120HZ)</th> <th>6.3</th> <th>10</th> <th>16</th> <th>25</th> <th>35</th> </tr> </thead> <tbody> <tr> <td>Z(-25°C) / Z(20°C)</td> <td>2</td> <td>2</td> <td>2</td> <td>2</td> <td>2</td> </tr> <tr> <td>Z(-40°C) / Z(20°C)</td> <td>3</td> <td>3</td> <td>3</td> <td>3</td> <td>3</td> </tr> </tbody> </table>	WV \ Z(120HZ)	6.3	10	16	25	35	Z(-25°C) / Z(20°C)	2	2	2	2	2	Z(-40°C) / Z(20°C)	3	3	3	3	3
WV \ Z(120HZ)	6.3	10	16	25	35														
Z(-25°C) / Z(20°C)	2	2	2	2	2														
Z(-40°C) / Z(20°C)	3	3	3	3	3														
Endurance	<p>After applying rated voltage with rated ripple current for 2000 hours at 105°C, the capacitor shall meet the following requirement.</p> <table border="1" style="width: 100%;"> <tbody> <tr> <td>Capacitance Change</td> <td>Within±30% of the initial value</td> </tr> <tr> <td>Dissipation Factor</td> <td>Not more than 200% of the specified value</td> </tr> <tr> <td>Leakage Current</td> <td>Not more than the specified value</td> </tr> </tbody> </table>	Capacitance Change	Within±30% of the initial value	Dissipation Factor	Not more than 200% of the specified value	Leakage Current	Not more than the specified value												
Capacitance Change	Within±30% of the initial value																		
Dissipation Factor	Not more than 200% of the specified value																		
Leakage Current	Not more than the specified value																		
Shelf Life	After placed at 105°C without voltage applied for 1000 hours, the capacitor shall meet the same requirement as Endurance.																		

■ Diagram of Dimensions(mm)

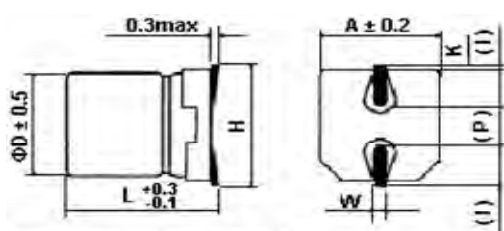

Φ8-Φ10&Φ6.3×7.7=L±0.3

() : Reference size

ψD	L	A	H	I	W	P	K	
4.0	5.4	4.3	5.5 Max	1.8	0.65±0.1	1.0±0.2	0.35	+0.15 -0.20
5.0	5.4	5.3	6.5 Max	2.2	0.65±0.1	1.5±0.2	0.35	+0.15 -0.20
6.3	5.4	6.6	7.8 Max	2.6	0.65±0.1	1.8±0.2	0.35	+0.15 -0.20
6.3	7.7	6.6	7.8 Max	2.6	0.65±0.1	1.8±0.2	0.35	+0.15 -0.20
8.0	10.2	8.3	10.0 Max	3.4	0.90±0.2	3.1±0.2	0.70±0.2	
10.0	10.2	10.3	12.0 Max	3.5	0.90±0.2	4.6±0.2	0.70±0.2	

■ Multiplier for Ripple Current

Frequency coefficient

Frequency (Hz)	120	1K	10K	100K
Coefficient	0.70	0.80	0.90	1.00

SURFACE MOUNT ALUMINUM ELECTROLYTIC

JV Ultra Low Impedance Series

■ Case Size / tanδ / Max Ripple Current / Impedance

Capacitance (μF)	Rated (Surge) Voltage											
	6.3(8)				10(13)				16(20)			
	ψDxL	tanδ	RC	Z	ψDxL	tanδ	RC	Z	ψDxL	tanδ	RC	Z
22									4x5.4	0.16	90	1.93
33					4x5.4	0.19	90	1.93	4x5.4	0.16	90	1.93
47	4x5.4	0.26	90	1.93	4x5.4	0.19	90	1.93	4x5.4	0.16	90	1.93
					5x5.4	0.19	160	1.00				
68	4x5.4	0.26	90	1.93	4x5.4	0.19	90	1.93	5x5.4	0.16	160	1.00
					5x5.4	0.19	160	1.00				
100	5x5.4	0.26	160	1.00	5x5.4	0.19	160	1.00	6.3x5.4	0.16	240	0.52
					6.3x5.4	0.19	240	0.52				
150	5x5.4	0.26	160	1.00	5x5.4	0.19	160	1.00	6.3x5.4	0.16	240	0.52
	6.3x5.4	0.26	240	0.52	6.3x5.4	0.19	240	0.52	6.3x7.7	0.16	280	0.34
220	6.3x5.4	0.26	240	0.52	6.3x5.4	0.19	240	0.52	6.3x7.7	0.16	280	0.34
					6.3x7.7	0.19	280	0.34				
330	6.3x5.4	0.26	240	0.52	6.3x7.7	0.19	280	0.34	6.3x7.7	0.16	280	0.34
	6.3x7.7	0.26	280	0.34					8x10.2	0.16	600	0.16
470	6.3x7.7	0.26	280	0.34	6.3x7.7	0.19	280	0.34	8x10.2	0.16	600	0.16
					8x10.2	0.19	600	0.16				
680	8x10.2	0.26	600	0.16	8x10.2	0.19	600	0.16	8x10.2	0.16	600	0.16
									10x10.2	0.16	850	0.08
1000	8x10.2	0.26	600	0.16	8x10.2	0.19	600	0.16	10x10.2	0.16	850	0.08
					10x10.2	0.19	850	0.08				
1200	8x10.2	0.26	600	0.16	10x10.2	0.19	850	0.08				
	10x10.2	0.26	850	0.08								
1500	10x10.2	0.26	850	0.08								
1800	10x10.2	0.26	850	0.08								

Capacitance (μF)	Rated (Surge) Voltage							
	25(32)				35(44)			
	ψDxL	tanδ	RC	Z	ψDxL	tanδ	RC	Z
10	4x5.4	0.14	90	1.93	4x5.4	0.12	90	1.93
22	4x5.4	0.14	90	1.93	5x5.4	0.12	160	1.00
	5x5.4	0.14	160	1.00				
33	5x5.4	0.14	160	1.00	5x5.4	0.14	160	1.00
					6.3x5.4	0.12	240	0.52
47	5x5.4	0.14	160	1.00	6.3x5.4	0.12	240	0.52
	6.3x5.4	0.14	240	0.52				
68	6.3x5.4	0.14	240	0.52	6.3x5.4	0.12	240	0.52
					6.3x7.7	0.12	280	0.34
100	6.3x5.4	0.14	240	0.52	6.3x7.7	0.12	280	0.34
	6.3x7.7	0.14	280	0.34				
150	6.3x7.7	0.14	280	0.34	8x10.2	0.12	600	0.16
220	8x10.2	0.14	600	0.16	8x10.2	0.12	600	0.16
330	8x10.2	0.14	600	0.16	10x10.2	0.12	850	0.08
470	10x10.2	0.14	850	0.08				
560	10x10.2	0.14	850	0.08				

☆ CASE SIZE : ψDxL(mm) 、 MAX DISSIPATION FACTOR : tanδ / 120Hz,20℃ 、
 MAX PERMISSIBLE RIPPLE CURRENT : RC(mArms) / 100KHz,105℃ 、
 MAX IMPEDANCE : Z(Ω) / 100KHz,20℃

SURFACE MOUNT ALUMINUM ELECTROLYTIC

XV Ultra Low Impedance & Long Life Series



■ Features : 105°C 3000~5000 hours , Low profile vertical chip, Ultra low impedance

■ Recommended Applications: AV(TV,Video,Audio) ,Monitor/Computer, OA/HA/Communication ,SMPS

■ Corresponding product to RoHS

Specifications

Item	Characteristics																					
Operating Temperature Range	-55 ~ +105°C																					
Rated Voltage Range (WV)	6.3 ~ 50VDC																					
Capacitance Range	1.0 ~ 1000μF																					
Capacitance Tolerance	± 20 % at 120Hz , 20°C																					
Leakage Current (MAX) (20°C)	$I \leq 0.01CV$ or $3\mu A$ whichever is greater(After rated voltage applied for 2 minutes) I = Leakage Current (μA) C = Nominal Capacitance (μF) V = Rated Voltage (V)																					
Dissipation Factor (MAX) (tanδ) (120Hz ,20°C)	Shown in the table of standard rating																					
Low Temperature Stability Impedance Ratio (MAX)	<table border="1" style="width: 100%; text-align: center;"> <thead> <tr> <th style="text-align: left;">WV \ Z(120HZ)</th> <th>6.3</th> <th>10</th> <th>16</th> <th>25</th> <th>35</th> <th>50</th> </tr> </thead> <tbody> <tr> <td>Z(-25°C) / Z(20°C)</td> <td>2</td> <td>2</td> <td>2</td> <td>2</td> <td>2</td> <td>2</td> </tr> <tr> <td>Z(-40°C) / Z(20°C)</td> <td>3</td> <td>3</td> <td>3</td> <td>3</td> <td>3</td> <td>3</td> </tr> </tbody> </table>	WV \ Z(120HZ)	6.3	10	16	25	35	50	Z(-25°C) / Z(20°C)	2	2	2	2	2	2	Z(-40°C) / Z(20°C)	3	3	3	3	3	3
WV \ Z(120HZ)	6.3	10	16	25	35	50																
Z(-25°C) / Z(20°C)	2	2	2	2	2	2																
Z(-40°C) / Z(20°C)	3	3	3	3	3	3																
Endurance	<p>After applying rated voltage with rated ripple current for 3000~5000 hours at 105°C , the capacitor shall meet the following requirement.</p> <table border="1" style="width: 100%; text-align: center;"> <tbody> <tr> <td>Capacitance Change</td> <td colspan="2">Within±30% of the initial value</td> </tr> <tr> <td>Dissipation Factor</td> <td colspan="2">Not more than 200% of the specified value</td> </tr> <tr> <td>Leakage Current</td> <td colspan="2">Not more than the specified value</td> </tr> <tr> <td>DΦ</td> <td>4x5.4~6.3x7.7</td> <td>8x10.2~10x10.2</td> </tr> <tr> <td>Life</td> <td>3000hrs</td> <td>5000hrs</td> </tr> </tbody> </table>	Capacitance Change	Within±30% of the initial value		Dissipation Factor	Not more than 200% of the specified value		Leakage Current	Not more than the specified value		DΦ	4x5.4~6.3x7.7	8x10.2~10x10.2	Life	3000hrs	5000hrs						
Capacitance Change	Within±30% of the initial value																					
Dissipation Factor	Not more than 200% of the specified value																					
Leakage Current	Not more than the specified value																					
DΦ	4x5.4~6.3x7.7	8x10.2~10x10.2																				
Life	3000hrs	5000hrs																				
Shelf Life	After placed at 105°C without voltage applied for 1000 hours, the capacitor shall meet the same requirement as Endurance.																					

Diagram of Dimensions(mm)

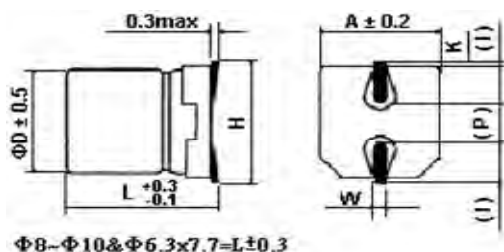

ψD	L	A	H	I	W	P	K	
4.0	5.4	4.3	5.5 Max	1.8	0.65±0.1	1.0±0.2	0.35	+0.15 -0.20
5.0	5.4	5.3	6.5 Max	2.2	0.65±0.1	1.5±0.2	0.35	+0.15 -0.20
6.3	5.4	6.6	7.8 Max	2.6	0.65±0.1	1.8±0.2	0.35	+0.15 -0.20
6.3	7.7	6.6	7.8 Max	2.6	0.65±0.1	1.8±0.2	0.35	+0.15 -0.20
8.0	10.2	8.3	10.0 Max	3.4	0.90±0.2	3.1±0.2	0.70±0.2	
10.0	10.2	10.3	12.0 Max	3.5	0.90±0.2	4.6±0.2	0.70±0.2	

Multiplier for Ripple Current

Frequency coefficient

Frequency (Hz)	120	1K	10K	100K
Coefficient	0.70	0.80	0.90	1.00

SURFACE MOUNT ALUMINUM ELECTROLYTIC

XV

Ultra Low Impedance & Long Life Series

■ **Case Size / tanδ / Max Ripple Current / Impedance**

Capacitance (μF)	Rated (Surge) Voltage											
	6.3(8)				10(13)				16(20)			
	ψDxL	tanδ	RC	Z	ψDxL	tanδ	RC	Z	ψDxL	tanδ	RC	Z
10									4x5.4	0.16	90	1.93
22	4x5.4	0.26	90	1.93	4x5.4	0.19	90	1.93	5x5.4	0.16	160	1.00
33	4x5.4	0.26	90	1.93	5x5.4	0.19	160	1.00	6.3x5.4	0.16	240	0.52
47	5x5.4	0.26	160	1.00	6.3x5.4	0.19	190	0.52	6.3x5.4	0.16	240	0.52
100	6.3x5.4	0.26	240	0.52	6.3x5.4	0.19	190	0.52	6.3x7.7	0.16	280	0.34
150	6.3x7.7	0.26	240	0.30	6.3x7.7	0.19	240	0.34	8x10.2	0.16	370	0.22
220	6.3x7.7	0.26	240	0.30	8x10.2	0.19	600	0.16	8x10.2	0.16	370	0.22
330	8x10.2	0.26	600	0.16	8x10.2	0.19	600	0.16	8x10.2	0.16	600	0.16
470	8x10.2	0.26	600	0.16	10x10.2	0.19	850	0.12	10x10.2	0.16	850	0.12
680	10x10.2	0.26	850	0.12	10x10.2	0.19	850	0.12	10x10.2	0.16	850	0.12
1000	10x10.2	0.26	850	0.12	10x10.2	0.19	850	0.12				

Capacitance (μF)	Rated (Surge) Voltage											
	25(32)				35(44)				50(63)			
	ψDxL	tanδ	RC	Z	ψDxL	tanδ	RC	Z	ψDxL	tanδ	RC	Z
1									4x5.4	0.12	60	5.00
2.2									4x5.4	0.12	60	5.00
3.3									4x5.4	0.12	60	5.00
4.7					4x5.4	0.12	90	1.93	5x5.4	0.12	95	4.00
10	4x5.4	0.14	90	1.93	5x5.4	0.12	160	1.00	6.3x5.4	0.12	140	2.60
22	5x5.4	0.14	160	1.00	5x5.4	0.12	160	1.00	6.3x7.7	0.12	230	1.30
33	6.3x5.4	0.14	240	0.52	6.3x5.4	0.12	240	0.52	8x10.2	0.12	350	0.50
47	6.3x5.4	0.14	240	0.52	6.3x7.7	0.12	280	0.34	10x10.2	0.12	670	0.34
68	6.3x7.7	0.14	280	0.34	6.3x7.7	0.12	280	0.34	10x10.2	0.12	670	0.34
100	6.3x7.7	0.14	300	0.34	8x10.2	0.12	600	0.16	10x10.2	0.12	670	0.34
150	8x10.2	0.14	600	0.16	10x10.2	0.12	850	0.12	10x10.2	0.12	670	0.34
220	8x10.2	0.14	600	0.16	10x10.2	0.12	850	0.12	10x10.2	0.12	670	0.34
330	10x10.2	0.14	850	0.12	10x10.2	0.12	850	0.12				
470	10x10.2	0.14	850	0.12								

☆ CASE SIZE : ψDxL(mm) 、 MAX DISSIPATION FACTOR : tanδ / 120Hz,20℃ 、
 MAX PERMISSIBLE RIPPLE CURRENT : RC(mArms) / 100KHz,105℃ 、
 MAX IMPEDANCE : Z(Ω) / 100KHz,20℃

SURFACE MOUNT ALUMINUM ELECTROLYTIC

HV

Ultra Low Impedance & High temperature Series

- Features : 125°C 1000~ 2000 hours ,Higher temperature range
- Recommended Applications: Automatic Mounting and Reflow Soldering
- Corresponding product to RoHS



■ Specifications

Item	Characteristics																		
Operating Temperature Range	-40 ~ +125°C																		
Rated Voltage Range (WV)	10 ~ 50VDC																		
Capacitance Range	47 ~ 1000μF																		
Capacitance Tolerance	± 20 % at 120Hz , 20°C																		
Leakage Current (MAX) (20°C)	$I \leq 0.01CV$ or $3\mu A$ whichever is greater (After rated voltage applied for 2 minutes) I = Leakage Current (μA) C = Nominal Capacitance (μF) V = Rated Voltage (V)																		
Dissipation Factor (MAX) (tanδ) (120Hz ,20°C)	Shown in the table of standard rating																		
Low Temperature Stability Impedance Ratio (MAX)	<table border="1" style="width: 100%; border-collapse: collapse; text-align: center;"> <tr> <td style="text-align: left;">WV \ Z(120HZ)</td> <td>10</td> <td>16</td> <td>25</td> <td>35</td> <td>50</td> </tr> <tr> <td>Z(-25°C) / Z(20°C)</td> <td>2</td> <td>2</td> <td>2</td> <td>2</td> <td>2</td> </tr> <tr> <td>Z(-40°C) / Z(20°C)</td> <td>3</td> <td>3</td> <td>3</td> <td>3</td> <td>3</td> </tr> </table>	WV \ Z(120HZ)	10	16	25	35	50	Z(-25°C) / Z(20°C)	2	2	2	2	2	Z(-40°C) / Z(20°C)	3	3	3	3	3
WV \ Z(120HZ)	10	16	25	35	50														
Z(-25°C) / Z(20°C)	2	2	2	2	2														
Z(-40°C) / Z(20°C)	3	3	3	3	3														
Endurance	<p>After applying rated voltage for 1000~2000 hours at 125°C, the capacitor shall meet the following requirement.</p> <table border="1" style="width: 100%; border-collapse: collapse; text-align: center;"> <tr> <td>Capacitance Change</td> <td colspan="2">Within ±30% of the initial value</td> </tr> <tr> <td>Dissipation Factor</td> <td colspan="2">Not more than 300% of the specified value</td> </tr> <tr> <td>DΦ</td> <td>6.3x7.7-8x6.2</td> <td>≥ 8x10.2</td> </tr> <tr> <td>Life</td> <td>1000hrs</td> <td>2000hrs</td> </tr> <tr> <td>Leakage Current</td> <td colspan="2">Not more than the specified value</td> </tr> </table>	Capacitance Change	Within ±30% of the initial value		Dissipation Factor	Not more than 300% of the specified value		DΦ	6.3x7.7-8x6.2	≥ 8x10.2	Life	1000hrs	2000hrs	Leakage Current	Not more than the specified value				
Capacitance Change	Within ±30% of the initial value																		
Dissipation Factor	Not more than 300% of the specified value																		
DΦ	6.3x7.7-8x6.2	≥ 8x10.2																	
Life	1000hrs	2000hrs																	
Leakage Current	Not more than the specified value																		
Shelf Life	After placed at 125°C without voltage applied for 1000 hours(500 hours for 8x6.2), the capacitor shall meet the same requirement as Endurance.																		

■ Diagram of Dimensions(mm)

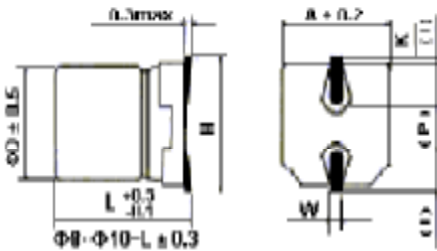

ψD	L	A	H	I	W	P	K	
8.0	6.2	8.3	9.5 Max	3.4	0.65±0.1	2.2±0.2	0.35	+0.15 -0.20
8.0	10.2	8.3	10.0 Max	3.4	0.90±0.2	3.1±0.2	0.70±0.2	
10.0	10.2	10.3	12.0 Max	3.5	0.90±0.2	4.6±0.2	0.70±0.2	

() : Reference size

■ Multiplier for Ripple Current

Frequency coefficient

Frequency (Hz)	120	1K	10K	100K
Coefficient	0.70	0.80	0.90	1.00

SURFACE MOUNT ALUMINUM ELECTROLYTIC

HV

High temperature
Series

■ Case Size / tanδ / Max Ripple Current

Capacitance (μF)	Rated (Surge) Voltage								
	10(13)			16(20)			25(32)		
	ψDxL	tanδ	RC	ψDxL	tanδ	RC	ψDxL	tanδ	RC
47				6.3x7.7	0.20	70	6.3x7.7	0.18	70
							8x6.2	0.18	75
100	8x6.2	0.26	75	6.3x7.7	0.20	70	6.3x7.7	0.18	70
							8x6.2	0.18	75
150	8x6.2	0.26	75	8x10.2	0.20	75	8x10.2	0.18	130
	6.3x7.7	0.26	70	8x10.2	0.20	130	8x10.2	0.18	130
220	8x10.2	0.26	130	8x10.2	0.20	130	10x10.2	0.18	180
330	8x10.2	0.26	130	8x10.2	0.20	180	10x10.2	0.18	180
470	10x10.2	0.26	180	10x10.2	0.20	180			
680	10x10.2	0.26	180						
1000	10x10.2	0.26	180						

Capacitance (μF)	Rated (Surge) Voltage					
	35(44)			50(63)		
	ψDxL	tanδ	RC	ψDxL	tanδ	RC
22	6.3x7.7	0.14	70	8x6.2	0.12	75
33	6.3x7.7	0.14	70	8x10.2	0.12	130
	8x6.2	0.14	75			
47	8x6.2	0.14	75	8x10.2	0.12	130
	8x10.2	0.14	130			
100	8x10.2	0.14	130	10x10.2	0.12	180
150	10x10.2	0.14	180			
220	10x10.2	0.14	180			
330						

☆CASE SIZE : ψDxL(mm) 、 MAX DISSIPATION FACTOR : tanδ / 120Hz,20℃ 、
MAX PERMISSIBLE RIPPLE CURRENT : RC(mArms) / 120Hz,125℃ 、

SURFACE MOUNT ALUMINUM ELECTROLYTIC

CV Low Leakage Series

- Features : 85°C 2000 hours , Low profile vertical chip,
Low Leakage current (0.5μA to 2.0μA max.)
- Recommended Applications: Security System , Backup Battery
- Corresponding product to RoHS



Specifications

Item	Characteristics																					
Operating Temperature Range	-40 ~ +85°C																					
Rated Voltage Range (WV)	6.3 ~ 50VDC																					
Capacitance Range	1 ~ 100μF																					
Capacitance Tolerance	± 20 % at 120Hz , 20°C																					
Leakage Current (MAX) (20°C)	$I \leq 0.002CV$ or 0.5μA whichever is greater(After rated voltage applied for 2 minutes) I = Leakage Current (μA) C = Nominal Capacitance (μF) V = Rated Voltage (V)																					
Dissipation Factor (MAX) (tanδ) (120Hz ,20°C)	Shown in the table of standard rating																					
Low Temperature Stability Impedance Ratio (MAX)	<table border="1" style="width: 100%; text-align: center;"> <thead> <tr> <th style="border: none;">WV \ Z(120HZ)</th> <th>6.3</th> <th>10</th> <th>16</th> <th>25</th> <th>35</th> <th>50</th> </tr> </thead> <tbody> <tr> <td style="border: none;">$Z(-25^\circ\text{C}) / Z(20^\circ\text{C})$</td> <td>4</td> <td>3</td> <td>2</td> <td>2</td> <td>2</td> <td>2</td> </tr> <tr> <td style="border: none;">$Z(-40^\circ\text{C}) / Z(20^\circ\text{C})$</td> <td>8</td> <td>6</td> <td>4</td> <td>4</td> <td>3</td> <td>3</td> </tr> </tbody> </table>	WV \ Z(120HZ)	6.3	10	16	25	35	50	$Z(-25^\circ\text{C}) / Z(20^\circ\text{C})$	4	3	2	2	2	2	$Z(-40^\circ\text{C}) / Z(20^\circ\text{C})$	8	6	4	4	3	3
WV \ Z(120HZ)	6.3	10	16	25	35	50																
$Z(-25^\circ\text{C}) / Z(20^\circ\text{C})$	4	3	2	2	2	2																
$Z(-40^\circ\text{C}) / Z(20^\circ\text{C})$	8	6	4	4	3	3																
Endurance	<p>After applying rated voltage for 2000 hours at 85°C , the capacitor shall meet the following requirement.</p> <table border="1" style="width: 100%; text-align: center;"> <tbody> <tr> <td>Capacitance Change</td> <td>Within ±25% of the initial value</td> </tr> <tr> <td>Dissipation Factor</td> <td>Not more than 200% of the specified value</td> </tr> <tr> <td>Leakage Current</td> <td>Not more than the specified value</td> </tr> </tbody> </table>	Capacitance Change	Within ±25% of the initial value	Dissipation Factor	Not more than 200% of the specified value	Leakage Current	Not more than the specified value															
Capacitance Change	Within ±25% of the initial value																					
Dissipation Factor	Not more than 200% of the specified value																					
Leakage Current	Not more than the specified value																					
Shelf Life	After placed at 85°C without voltage applied for 1000 hours, the capacitor shall meet the same requirement as Endurance.																					

Diagram of Dimensions(mm)

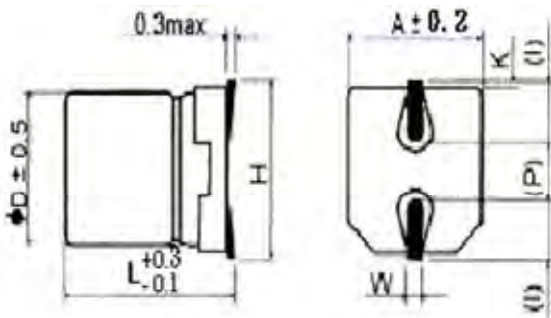

ψD	L	A	H	I	W	P	K
4.0	5.4	4.3	5.5 Max	1.8	0.65±0.1	1.0±0.2	0.35 +0.15 -0.20
5.0	5.4	5.3	6.5 Max	2.2	0.65±0.1	1.5±0.2	0.35 +0.15 -0.20
6.3	5.4	6.6	7.8 Max	2.6	0.65±0.1	1.8±0.2	0.35 +0.15 -0.20

Multiplier for Ripple Current

Frequency coefficient

Frequency (Hz)	60	120	1K	10K
Coefficient	0.8	1.0	1.15	1.25

SURFACE MOUNT ALUMINUM ELECTROLYTIC

CV Low Leakage Series

■ Case Size / tanδ / Max Ripple Current / ESR

Capacitance (μF)	Rated (Surge) Voltage								
	6.3(8)			10(13)			16(20)		
	ψDxL	tanδ	RC	ψDxL	tanδ	RC	ψDxL	tanδ	RC
10							4x5.4	0.16	28
22	4x5.4	0.26	20	4x5.4	0.30	28	5x5.4	0.16	39
33	5x5.4	0.26	22	5x5.4	0.20	43	6.3x5.4	0.16	66
47	5x5.4	0.26	46	5x5.4	0.30	43	6.3x5.4	0.16	70
100	6.3x5.4	0.26	71	6.3x5.4	0.26	70			

Capacitance (μF)	Rated (Surge) Voltage								
	25(32)			35(44)			50(63)		
	ψDxL	tanδ	RC	ψDxL	tanδ	RC	ψDxL	tanδ	RC
1							4x5.4	0.12	10
2.2							4x5.4	0.12	16
3.3							4x5.4	0.12	16
4.7	4x5.4	0.14	22	4x5.4	0.12	22	5x5.4	0.12	23
10	5x5.4	0.14	28	5x5.4	0.12	30	6.3x5.4	0.12	35
22	6.3x5.4	0.14	55	6.3x5.4	0.12	60			
33	6.3x5.4	0.14	65						

☆CASE SIZE : ψDxL(mm) 、 MAX DISSIPATION FACTOR : tanδ /
 120Hz,20℃ 、 MAX PERMISSIBLE
 RIPPLE CURRENT : RC(mArms) / 120Hz,85℃ 、

SURFACE MOUNT ALUMINUM ELECTROLYTIC

NV Non-polar Series

■ Features :105°C 2000 hours,Non-polarized,Low profile vertical chip, 5.5mm height ($\leq \psi 6.3$)

■ Recommended Applications: Suitable for AV(TV,Video,Audio),Monitor/Computer, OA/HA/Communication,Reversed polarity circuit

■ Corresponding product to RoHS



■ Specifications

Item	Characteristics																												
Operating Temperature Range	-40 ~ +105°C																												
Rated Voltage Range (WV)	6.3 ~ 50VDC																												
Capacitance Range	1 ~ 47µF																												
Capacitance Tolerance	± 20 % at 120Hz , 20°C																												
Leakage Current (MAX) (20°C)	$I \leq 0.01CV$ or $3(\mu A)$, whichever is greater. (After rated voltage applied for 2 minutes) I= Leakage Current (µA) C= Nominal Capacitance (µF) V= Rated Voltage (V)																												
Dissipation Factor (MAX) (tanδ) (120Hz ,20°C)	Shown in the table of standard rating																												
Low Temperature Stability Impedance Ratio (MAX)	<table border="1" style="width: 100%; text-align: center;"> <thead> <tr> <th style="border: none;">WV</th> <th>6.3</th> <th>10</th> <th>16</th> <th>25</th> <th>35</th> <th>50</th> </tr> </thead> <tbody> <tr> <td style="border: none;">$Z(120HZ)$</td> <td></td> <td></td> <td></td> <td></td> <td></td> <td></td> </tr> <tr> <td style="border: none;">$Z(-25^\circ C) / Z(20^\circ C)$</td> <td>4</td> <td>3</td> <td>2</td> <td>2</td> <td>2</td> <td>2</td> </tr> <tr> <td style="border: none;">$Z(-40^\circ C) / Z(20^\circ C)$</td> <td>8</td> <td>6</td> <td>4</td> <td>4</td> <td>3</td> <td>3</td> </tr> </tbody> </table>	WV	6.3	10	16	25	35	50	$Z(120HZ)$							$Z(-25^\circ C) / Z(20^\circ C)$	4	3	2	2	2	2	$Z(-40^\circ C) / Z(20^\circ C)$	8	6	4	4	3	3
WV	6.3	10	16	25	35	50																							
$Z(120HZ)$																													
$Z(-25^\circ C) / Z(20^\circ C)$	4	3	2	2	2	2																							
$Z(-40^\circ C) / Z(20^\circ C)$	8	6	4	4	3	3																							
Endurance	<p>After applying rated voltage for 2000hrs at 105°C, the capacitors shall meet the following requirements. (The polarity shall be reversed every 250 hours)</p> <table border="1" style="width: 100%; text-align: center;"> <tbody> <tr> <td>Capacitance Change</td> <td>Within ±20% of the initial value</td> </tr> <tr> <td>Dissipation Factor</td> <td>Not more than 200% of the specified value</td> </tr> <tr> <td>Leakage Current</td> <td>Not more than the specified value</td> </tr> </tbody> </table>	Capacitance Change	Within ±20% of the initial value	Dissipation Factor	Not more than 200% of the specified value	Leakage Current	Not more than the specified value																						
Capacitance Change	Within ±20% of the initial value																												
Dissipation Factor	Not more than 200% of the specified value																												
Leakage Current	Not more than the specified value																												
Shelf Life	After placed at 105°C without voltage applied for 1000 hours, the capacitor shall meet the same requirement as Endurance.																												

■ Diagram of Dimensions(mm)

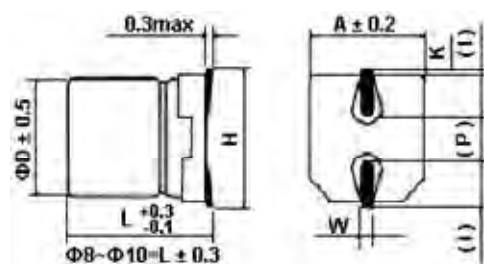

() : Reference size

ψD	L	A	H	I	W	P	K
4.0	5.4	4.3	5.5 Max	1.8	0.65±0.1	1.0±0.2	0.35 +0.15 -0.20
5.0	5.4	5.3	6.5 Max	2.2	0.65±0.1	1.5±0.2	0.35 +0.15 -0.20
6.3	5.4	6.6	7.8 Max	2.6	0.65±0.1	1.8±0.2	0.35 +0.15 -0.20

■ Multiplier for Ripple Current

Frequency coefficient

Frequency (Hz)	60	120	1K	10K
Coefficient	0.85	1.00	1.10	1.20

SURFACE MOUNT ALUMINUM ELECTROLYTIC

NV Non-polar Series

■ Dimensions, Max Dissipation Factor, Max Permissible Ripple Current

Capacitance e (μ F)	Rated (Surge) Voltage											
	6.3(8)			10(13)			16(20)			25(32)		
	Size	tan δ	Ripple	Size	tan δ	Ripple	Size	tan δ	Ripple	Size	tan δ	Ripple
2.2												
3.3										4x5.4	0.28	12
4.7							4x5.4	0.32	20	5x5.4	0.28	21
10				4x5.4	0.40	25	5x5.4	0.32	25	6.3x5.4	0.28	28
22	5x5.4	0.52	29	6.3x5.4	0.40	39	6.3x5.4	0.32	39			
33	6.3x5.4	0.52	43	6.3x5.4	0.40	43						
47	6.3x5.4	0.52	46									

Capacitance e (μ F)	Rated (Surge) Voltage					
	35(44)			50(63)		
	Size	tan δ	Ripple	Size	tan δ	Ripple
1				4x5.4	0.24	10
2.2	4x5.4	0.24	12	5x5.4	0.24	16
3.3	5x5.4	0.24	21	5x5.4	0.24	21
4.7	5x5.4	0.24	22	6.3x5.4	0.24	31
10	6.3x5.4	0.24	30			

☆Size: D ψ x L(mm). ☆tan δ : 20°C, 120Hz. ☆Ripple Current: 105°C, 120Hz, (mA/rms).

ALUMINUM ELECTROLYTIC CAPACITORS

SK General purpose Series

- Features: 85°C 2000 hours
- Recommended Applications: For general purpose , decoupling , by pass and filtering circuit in entertainment electronics
- Corresponding product to RoHS

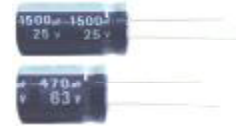

Specifications

Item	Characteristics										
Operating Temperature Range	-40~+85°C					-25~+85°C					
Rated Voltage Range	6.3 ~ 100VDC					160 ~ 500VDC					
Rated Capacitance Range	1 ~ 22000µF					1 ~ 470µF					
Capacitance Tolerance	± 20 % at 120Hz , 20°C										
Leakage Current (MAX) (20°C)	I=0.01CV or 3µA whichever is greater.					I=0.03CV+10(µA)					
	(After rated voltage applied for 2 minutes)										
Dissipation Factor (MAX) (tanδ) (120Hz ,20°C)	WV	6.3	10	16	25	35	50	63	100	160~250	350~500
	tanδ	0.24	0.20	0.16	0.14	0.12	0.10	0.10	0.10	0.20	0.24
	When nominal capacitance is over 1000µF , tanδ shall be added 0.02 to the listed value with increase of every 1000µF .										
Low Temperature Stability Impedance Ratio (MAX)	Z(120Hz)	WV		6.3	10	16	25	35~100	160~250	315~350	400~500
	Z-25°C / Z+20°C			8	6	5	3	3	7	10	15
	Z-40°C / Z+20°C			10	8	6	4	3	—	—	—
Endurance	After applying rated voltage for 2000 hours at 85°C the capacitors shall meet the following requirements.										
	Capacitance Change	Within ± 20 % of initial value									
	Dissipation Factor	Not more than 200% of the specified value									
	Leakage Current	initial specified value or less									
Shelf Life	After placed at 85°C without voltage applied for 1000 hours, the capacitors shall meet the same requirement as Endurance.										

Diagram of Dimensions

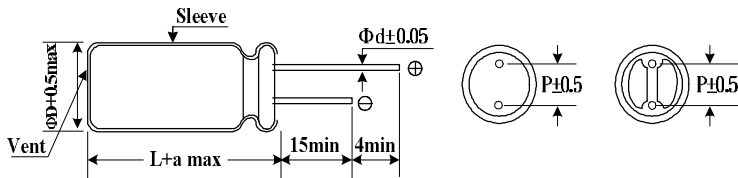

ψD	5	6.3	8	10	13	16	18	22
P	2.0	2.5	3.5	5.0		7.5		10.0
ψd	0.5	0.5	0.6	0.6		0.8		0.8
a	1.5	1.5	1.5	1.5	2.0	2.0	2.0	2.0

Multiplier for Ripple Current

Frequency coefficient

Frequency (Hz)	120	300	1K	10K
6.3 ~ 100V Below 68µF	1.00	1.20	1.30	1.50
6.3 ~ 100V 100 ~ 680µF	1.00	1.10	1.15	1.20
6.3 ~ 100V 1000 ~ 22000µF	1.00	1.05	1.10	1.15
160 ~ 450V Below 220µF	1.00	1.25	1.40	1.40
160 ~ 450V 220µF Above	1.00	1.10	1.13	1.13
500V	1.00	1.05	1.10	1.10

ALUMINUM ELECTROLYTIC CAPACITORS



**General purpose
Series**

■ Dimensions, Rated Ripple Current

Capacitance (μ F)	Rated (Surge) Voltage														
	6.3 (8)		10 (13)		16 (20)		25 (32)		35 (44)		50 (63)		63 (79)		
	Size	Ripple	Size	Ripple	Size	Ripple	Size	Ripple	Size	Ripple	Size	Ripple	Size	Ripple	
1.0												5x11	10	5x11	10
2.2												5x11	23	5x11	29
3.3												5x11	35	5x11	40
4.7			5x11	20	5x11	25	5x11	30	5x11	35	5x11	40	5x11	45	
6.8												5x11	50		
10			5x11	35	5x11	40	5x11	50	5x11	60	5x11	65	5x11	70	
22	5x11	35	5x11	55	5x11	75	5x11	90	5x11	95	5x11	100	5x11	95	
														6.3x11	115
33	5x11	55	5x11	80	5x11	110	5x11	115	5x11	120	5x11	105	6.3x11	130	
47	5x11	75	5x11	95	5x11	130	5x11	135	5x11	120	6.3x11	140	6.3x11	190	
68					5x11	150	5x11	145							
100	5x11	130	5x11	180	5x11	165	6.3x11	160	6.3x11	185	8x11	230	10x12.5	300	
150					6.3x11	205									
220	5x11	200	6.3x11	250	6.3x11	260	8x11	290	8x11	290	10x12.5	380	10x15	410	
	6.3x11	240											10x20	490	
330	6.3x11	260	6.3x11	265	6.3x11	290	8x11	315	10x12.5	420	10x15	490	10x20	540	
					8x11	360									
470	6.3x11	330	6.3x11	320	8x11	400	8x15	420	10x15	430	10x20	610	13x20	755	
							10x12.5	460							
680	8x11	410	8x11	410	10x12.5	510	10x15	550	10x20	550			13x25	965	
1000	8x11	460	10x12.5	580	10x15	630	10x20	760	13x20	950	13x25	1100	16x25	1310	
	10x12.5	580					13x16	760							
2200	10x20	840	10x20	880	13x20	1100	13x25	1300	16x25	1600	16x36	1850	18x36	2200	
											18x32	1850			
3300	10x20	1000	13x20	1250	13x25	1400	16x25	1660	16x36	1970	18x36	2170	22x40	2500	
									18x32	2050					
4700	13x20	1300	13x25	1500	16x25	1800	16x32	1950	18x36	2400	22x40	2500			
6800	13x25	1550	16x25	1900	16x32	1980	18x36	2550	22x40	2600					
10000	16x25	1900	16x36	2225	18x36	2700	22x40	2800							
			18x32	2225											
15000	16x36	2500	18x36	2950	22x40	3150	22x40	3200							
22000	18x40	3650	22x40	3700	22x40	3800									

☆ Size: D \times L (mm) ☆ Ripple Current: (mA/rms). 85°C, 120Hz

ALUMINUM ELECTROLYTIC CAPACITORS

SK General purpose Series

■ Dimensions, Rated Ripple Current

Capacitance (μF)	Rated (Surge) Voltage															
	100 (125)		160 (200)		200 (250)		250 (300)		350 (400)		400 (450)		450 (500)		500(550)	
	Size	Ripple	Size	Ripple	Size	Ripple	Size	Ripple	Size	Ripple	Size	Ripple	Size	Ripple	Size	Ripple
1.0	5x11	21	5x11	17	5x11	19	5x11	17	6.3x11	19	6.3x11	16	8x11	19		
			6.3x11	17			6.3x11	19			8x11	19				
2.2	5x11	30	6.3x11	26	6.3x11	22	6.3x11	24	8x11	33	6.3x11	20	10x12.5	33		
							8x11	30			8x11	26			10x12.5	33
3.3	5x11	45	6.3x11	30	6.3x11	30	8x11	30	8x11	33	8x11	35	10x12.5	40	10x15	43
4.7	5x11	50	6.3x11	32	6.3x11	35	8x11	36	10x12.5	39	8x11	38	10x12.5	45		
											10x12.5	42				
6.8	5x11	55			8x11	40	8x11	40			8x15	42	10x15	50	10x20	70
											10x12.5	45				
10	5x11	65	8x11	50	8x11	45	10x12.5	65	10x15	70	10x15	50	10x20	58	13x20	93
	6.3x11	75											13x20	60		
22	6.3x11	105	10x15	110	10x15	120	10x20	130	13x20	130	13x20	100	13x25	98	16x25	105
	8x11	130														
33	8x11	140	10x15	135	10x20	160	13x20	140	13x25	170	13x25	140	16x25	145	16x25	200
			10x20	150												
47	10x12.5	190	10x20	160	10x20	170	13x25	210	16x25	220	16x25	180	16x32	165	18x32	185
					13x20	200							18x25	160		
68	10x15	280	13x20	200	13x25	230					16x32	250	18x32	265	18x36	370
											18x25	220				
100	10x20	400	13x25	250	16x25	330	16x25	250	16x36	320	18x32	320	18x40	330		
									18x32	300						
150	13x20	500	16x25	330			16x32	330			18x40	420	22x35	420		
220	13x25	710	16x32	450	16x32	505	18x36	540								
					18x25	485										
330	13x25	720	18x36	540	16x40	710										
					18x32	685										
470	16x25	1100	18x40	750	18x40	750										
680	16x36	1260														
1000	18x40	1350														
2200																

☆ Size: Dφx L (mm) ☆ Ripple Current: (mA/rms). 85°C, 120Hz

ALUMINUM ELECTROLYTIC CAPACITORS

SE **General Purpose**
Series

- Features: 105°C 1000 hours
- Recommended Applications: For general purpose coupling, decoupling, by pass, and filtering circuit in entertainment electronics
- Corresponding product to RoHS

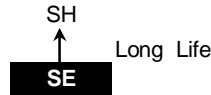

■ **Specifications**

Item	Characteristics									
Operating Temperature Range	-40~+105°C			-40~+105°C			-25~+105°C			
Rated Voltage Range	6.3 ~ 100VDC			160 ~ 250VDC			350 ~ 450VDC			
Rated Capacitance Range	1 ~ 15000µF			1 ~ 470µF			1 ~ 150µF			
Capacitance Tolerance	± 20 % at 120Hz, 20°C									
Leakage Current (MAX)(20°C)	I=0.01CV or 3(µA), whichever is greater.					I=0.03CV+10(µA)				
	(After rated voltage applied for 2 minutes)									
Dissipation Factor (MAX) (tanδ) (120Hz, 20°C)	WV	6.3	10	16	25	35	50	63~100	160~250	350~450
	tanδ	0.26	0.22	0.18	0.16	0.14	0.12	0.10	0.15	0.20
	When nominal capacitance is over 1000uF , tanδ shall be added 0.02 to the listed value with increase of every 1000uF .									
Low Temperature Stability Impedance Ratio (MAX)	WV	6.3	10	16	25	35~100	160~250	315~350	400~450	
	Z(120Hz)									
	Z-25°C / Z+20°C	8	6	5	3	3	7	10	15	
	Z-40°C / Z+20°C	10	8	6	4	3	7	—	—	
Endurance	After applying rated voltage for 1000 hours at 105°C the capacitors shall meet the following requirements.									
	Capacitance Change	Within ± 20 % of initial value								
	Leakage Current	initial specified value or less								
Shelf Life	After leaving capacitors under no load at 105°C for 500 hours. the capacitors shall meet the same requirement as Endurance.									

■ **Diagram of Dimensions**

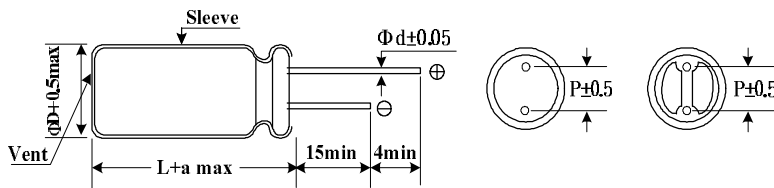

ψD	5	6.3	8	10	13	16	18	22
P	2.0	2.5	3.5	5.0		7.5		10.0
ψd	0.5	0.5	0.6	0.6		0.8		0.8
a	1.5	1.5	1.5	1.5	2.0	2.0	2.0	2.0

■ **Multiplier for Ripple Current**

Frequency coefficient

Frequency (Hz)	120	300	1K	10K
6.3 ~ 100V Below 68µF	1.00	1.20	1.30	1.45
6.3 ~ 100V 100 ~ 680µF	1.00	1.10	1.15	1.25
6.3 ~ 100V 1000 ~ 22000µF	1.00	1.05	1.10	1.15
160 ~ 450V ALL Cap (µF)	1.00	1.05	1.10	1.50

ALUMINUM ELECTROLYTIC CAPACITORS

SE General Purpose Series

■ Dimensions, Rated Ripple Current

Capacitance (μF)	Rated (Surge) Voltage													
	6.3 (8)		10 (13)		16 (20)		25 (32)		35 (44)		50 (63)		63 (79)	
	Size	Ripple	Size	Ripple	Size	Ripple	Size	Ripple	Size	Ripple	Size	Ripple	Size	Ripple
1.0											5x11	12	5x11	13
2.2											5x11	18	5x11	20
3.3											5x11	25	5x11	27
4.7							5x11	20	5x11	25	5x11	30	5x11	34
6.8							5x11	25	5x11	30	5x11	32	5x11	37
10					5x11	25	5x11	30	5x11	40	5x11	50	5x11	55
15					5x11	40	5x11	45	5x11	50	5x11	60	5x11	65
22			5x11	45	5x11	55	5x11	60	5x11	65	5x11	75	6.3x11	90
33			5x11	60	5x11	70	5x11	75	5x11	85	5x11	95	6.3x11	110
47	5x11	60	5x11	75	5x11	85	5x11	90	5x11	95	6.3x11	105	8x11	155
68	5x11	75	5x11	80	5x11	100	6.3x11	125	6.3x11	125	8x11	159		
100	5x11	100	5x11	110	5x11	110	6.3x11	145	6.3x11	150	8x11	160	8x15	230
													10x12.5	260
150	5x11	120	5x11	110	6.3x11	175	8x11	200	8x11	200	10x12.5	289	10x15	330
220	5x11	140	6.3x11	180	6.3x11	180	8x11	200	8x11	230	10x12.5	340	10x15	400
	6.3x11	165							10x12.5	315			10x20	460
330	6.3x11	160	6.3x11	205	8x11	285	8x11	265	8x15	345	10x20	535	10x20	520
							8x15	320	10x12.5	380				
470	6.3x11	220	6.3x11	245	8x11	310	8x15	365	10x15	415	10x20	580	13x20	700
			8x11	305							13x20	730		
680	8x11	255	8x11	335	10x12.5	455	10x15	650	10x20	680	13x25	860	13x25	840
			10x12.5	420										
1000	8x11	370	8x15	450	8x20	600	10x20	680	13x20	850	13x25	930	16x25	1020
	10x12.5	470	10x12.5	490	10x15	590								
1500	10x15	600	10x20	750	10x20	680	13x20	880	13x25	935	16x25	1220	16x32	1300
2200	10x20	740	10x20	800	13x20	990	13x25	1030	16x25	1230	16x36	1360	18x36	1455
3300	13x20	1100	10x25	950	13x25	1140	16x25	1230	16x36	1470	18x36	1540		
			13x20	1050										
4700	13x25	1100	13x25	1190	16x25	1330	16x32	1420	18x36	1580				
6800	13x25	1250	16x25	1370	16x32	1580	18x36	1850						
10000	16x25	1560	16x36	1760	18x36	2150								
15000	18x32	2100	18x36	2150										

☆ Size: Dφx L (mm) ☆ Ripple Current: (mA/rms). 105°C, 120Hz

ALUMINUM ELECTROLYTIC CAPACITORS

SE

General Purpose Series

■ Dimensions, Rated Ripple Current

Capacitance (μ F)	Rated (Surge) Voltage													
	100 (125)		160 (200)		200 (250)		250 (300)		350 (400)		400 (450)		450 (500)	
	Size	Ripple	Size	Ripple	Size	Ripple	Size	Ripple	Size	Ripple	Size	Ripple	Size	Ripple
1.0	5x11	15	5x11	17	5x11	19	6.3x11	19	6.3x11	20	6.3x11	16	6.3x11	16
											8x11	20	8x11	20
2.2	5x11	22	6.3x11	25	6.3x11	22	6.3x11	23	8x11	35	6.3x11	20	8x11	28
											8x11	28	10x12.5	35
3.3	5x11	29	6.3x11	30	6.3x11	32	8x11	33	8x11	37	8x11	38	10x12.5	49
4.7	5x11	37	6.3x11	34	8x11	40	8x11	41	8x11	47	8x11	40	10x12.5	55
											10x12.5	49		
6.8	5x11	46	8x11	50	8x11	56	8x11	57			8x15	50	10x15	65
											10x12.5	52		
10	5x11	55	8x11	56	10x12.5	69	10x12.5	78	10x15	95	10x15	65	10x20	75
	6.3x11	65												
15	6.3x11	72	10x12.5	80	10x15	110	10x15	120	10x20	140	10x20	100	13x20	125
22	8x11	115	10x15	130	10x15	140	10x20	155	13x20	165	13x20	150	13x25	160
33	8x11	120	10x20	180	10x20	190	13x20	170	13x25	220	13x25	190	16x25	210
											16x20	195		
47	10x12.5	180	10x20	230	13x20	240	13x25	330	16x25	340	16x25	280	16x32	270
											18x20	275		
68	10x15	241	13x20	270	13x25	330	13x25	340			16x32	320	18x32	305
											18x25	305		
100	10x20	385	13x25	330	16x25	410	16x25	415	18x32	430	18x32	430	18x36	380
120											18x32	440		
150	13x20	414	16x25	410	16x32	430	16x32	435	18x40	480	18x36	450		
											18x40	460		
180											18x45	480		
220	13x25	590	16x32	550	16x36	520	18x36	600						
					18x32	520								
330	13x25	600	18x36	770	18x36	705								
470	16x25	740	18x40	800										
680	16x36	1200												
1000	18x40	1340												

☆ Size: D \times L (mm) ☆ Ripple Current: (mA/rms). 105°C, 120Hz

ALUMINUM ELECTROLYTIC CAPACITORS

SH Miniature and general purpose Series

- Features: 105°C 2000 hours
- Recommended Applications: For high quality , reliability application, high CV product
- Corresponding product to RoHS

SH
↑
SE Long Life



Specifications

Item	Characteristics										
Operating Temperature Range	-40~+105°C			-25~+105°C				-25~+105°C			
Rated Voltage Range	6.3 ~ 100VDC			160 ~ 450VDC				500VDC			
Rated Capacitance Range	1 ~ 22000µF			1 ~ 470µF				2.2~82µF			
Capacitance Tolerance	± 20 % at 120Hz , 20°C										
Leakage Current (MAX)(20°C)	I=0.01CV or 3(µA) ,whichever is greater.			I=0.03CV+10(µA)				I=0.04CV+100(uA)			
Dissipation Factor (MAX) (tanδ) (120Hz ,20°C)	WV	6.3	10	16	25	35	50	63~100	160~250	350~450	500
	tanδ	0.26	0.22	0.18	0.16	0.14	0.12	0.10	0.15	0.20	0.25
	When nominal capacitance is over 1000uF , tanδ shall be added 0.02 to the listed value with increase of every 1000uF .										
Low Temperature Stability Impedance Ratio (MAX)	Z(120Hz)			6.3	10	16	25~100	160~250	350~450	500	
	Z-25°C / Z+20°C			4	3	2	2	4	4	6	
	Z-40°C / Z+20°C			8	6	4	3	-	-	-	
Endurance	After applying rated voltage for 2000 hours at 105°C the capacitors shall meet the following requirements.										
	Capacitance Change		Within ± 20 % of initial value								
	Dissipation Factor		Not more than 200% of the specified value								
Shelf Life	After leaving capacitors under no load at 105°C for 1000 hours. the capacitors shall meet the same requirement as Endurance.										

Diagram of Dimensions

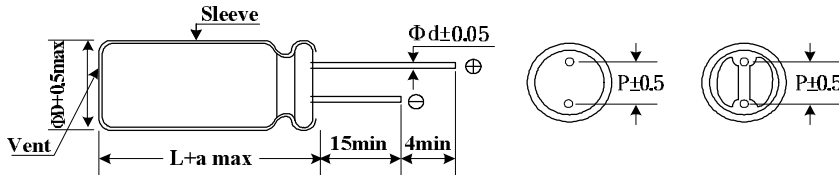

ψD	5	6.3	8	10	13	16	18	22
p	2.0	2.5	3.5	5.0		7.5		10.0
ψd	0.5	0.5	0.6	0.6		0.8		0.8
a	1.5	1.5	1.5	1.5	2.0	2.0	2.0	2.0

Multiplier for Ripple Current

Frequency coefficient

Frequency (Hz)	120	300	1K	10K
6.3 ~ 100V Below 68µF	1.00	1.30	1.57	2.00
6.3 ~ 100V 100 ~ 470µF	1.00	1.23	1.34	1.50
6.3 ~ 100V 471 ~ 22000µF	1.00	1.10	1.13	1.15
160 ~ 450V ALL Cap (µF)	1.00	1.25	1.40	1.60
500V ALL Cap (µF)	1.00	1.05	1.10	1.15

ALUMINUM ELECTROLYTIC CAPACITORS

SH

Miniature and general purpose
Series

■ Dimensions, Rated Ripple Current

Capacitance (μ F)	Rated (Surge) Voltage																
	6.3 (8)		10 (13)		16 (20)		25 (32)		35 (44)		50 (63)		63 (79)		100 (125)		
	Size	Ripple	Size	Ripple	Size	Ripple	Size	Ripple	Size	Ripple	Size	Ripple	Size	Ripple	Size	Ripple	
1.0											5x11	12	5x11	12	5x11	15	
2.2											5x11	18	5x11	20	5x11	22	
3.3											5x11	25	5x11	27	5x11	29	
4.7											5x11	30	5x11	34	5x11	37	
6.8											5x11	30	5x11	37	5x11	46	
10										5x11	44	5x11	50	5x11	55	6.3x11	65
15										5x11	50	5x11	50	5x11	65	6.3x11	75
22							5x11	60	5x11	65	5x11	75	6.3x11	90	8x11	115	
33					5x11	70	5x11	75	5x11	85	5x11	95	6.3x11	100	8x11	140	
47			5x11	75	5x11	85	5x11	90	5x11	100	6.3x11	115	8x11	155	10x12.5	185	
68			5x11	80	5x11	100	6.3x11	125	6.3x11	130	8x11	159	10x12.5	198	10x15	240	
100	5x11	100	5x11	110	5x11	130	6.3x11	145	6.3x11	170	8x11	200	10x12.5	260	10x20	305	
150	5x11	120	5x11	120	6.3x11	175	8x11	200	8x11	220	10x12.5	289	10x15	330	13x20	370	
220	6.3x11	165	6.3x11	180	6.3x11	220	8x11	240	10x12.5	315	10x12.5	360	10x20	465	13x25	520	
											10x15	415					
330	6.3x11	200	6.3x11	235	8x11	280	8x11	300	10x12.5	400	10x20	535	13x20	650	16x25	720	
			8x11	255			10x12.5	355									
470	6.3x11	230	6.3x11	250	8x11	375	8x15	420	10x15	480	10x20	630	13x20	700	16x32	875	
			8x11	305			10x12.5	440			13x20	730					
680	8x11	350	8x11	365	8x15	450	10x15	560	10x20	650	13x20	800	16x25	1000	16x36	1200	
			10x12.5	420	10x12.5	480											
1000	8x15	445	8x15	480	10x15	640	10x20	740	13x20	900	13x25	1060	16x32	1200			
	10x12.5	470	10x12.5	540													
1500	10x15	600	10x20	800	10x20	830	13x20	920	13x25	1050	16x25	1300	16x36	1450			
2200	10x20	800	10x20	870	13x20	1050	13x25	1230	16x25	1370	16x36	1600	18x36	1650			
3300	13x20	1100	13x20	1100	13x25	1250	16x25	1500	16x36	1680	18x36	1780					
4700	13x20	1180	13x25	1380	16x25	1650	16x32	1800	18x36	1920							
6800	13x25	1490	16x25	1700	16x32	1900	18x36	2050									
10000	16x32	1830	16x36	1950	18x36	2070											
15000	16x36	2090	18x36	2180													
22000	18x40	2350															

☆ Size: D \times L (mm) ☆ Ripple Current: (mA/rms). 105°C, 120Hz

ALUMINUM ELECTROLYTIC CAPACITORS

SH Miniature and general purpose Series

■ Dimensions, Rated Ripple Current

Capacitance (μF)	Rated (Surge) Voltage															
	160 (200)		200 (250)		250 (300)		350 (400)		400 (450)		420 (470)		450 (500)		500 (550)	
	Size	Ripple	Size	Ripple	Size	Ripple	Size	Ripple	Size	Ripple	Size	Ripple	Size	Ripple	Size	Ripple
1.0	5x11	17	6.3x11	17	6.3x11	17	6.3x11	16	6.3x11	17	6.3x11	17	6.3x11	18		
													8x11	22		
2.2	6.3x11	25	6.3x11	25	6.3x11	29	8x11	31	8x11	31	8x11	29	8x11	30	8x11	25
													10x12.5	37		
3.3	6.3x11	36	6.3x11	36	8X11	42	8x11	35	8x11	35	8x11	34	8X15	42	8X16	30
													10x12.5	40		
4.7	6.3x11	43	8x11	50	8x11	52	8x11	45	8x11	45	10X12.5	55	10x12.5	52	8X16	34
										10X12.5	55				10X12.5	38
6.8	8X11	54	8X11	60	8x11	62			8X15	60	10X15	68	10X15	62	10X16	50
									10X12.5	65						
8.2																
10	8X11	70	10X12.5	80	10x12.5	80	10x15	80	10X15	80	10X20	98	10X20	85	10X20	70
															13x20	85
15	10X12.5	90	10x15	110	10X15	110			10X20	100	13X20	130	13X20	120	13X25	100
22	10X15	115	10x20	140	10X20	140	13X20	150	13x20	150	13X25	155	13X25	150	13X25	115
															16X25	130
33	10X20	160	13x20	200	13X20	200	13X25	200	13X25	200	16x25	205	16X25	210	18X25	180
47	10x20	195	13x20	220	13X25	240	16X25	260	16x25	265	16x25	235	16X25	260	16X32	180
															18X30	230
68	13x20	255	13x25	280	13x25	290			16X32	410	16X32	400	18X32	370	18X32	250
									18x25	390	18x25	380			18X36	290
82															18X40	335
100	13X25	350	16x25	350	16X25	380	18x32	400	18X32	500	18X36	490	18X36	495		
120									18X32	520	18x40	530	18X40	565		
									18x36	550						
150	16X25	435	16x32	480	16X32	420			18x40	620	18x45	570	18X45	650		
220	16x32	550	16x36	675	18X36	680										
			18X32	685												
330	18x36	800	18x36	750												
470	18x40	900														
680																

☆ Size: D \times L (mm) ☆ Ripple Current: (mA/rms). 105°C, 120Hz

ALUMINUM ELECTROLYTIC CAPACITORS

D5 5mm height Series

- Features : 85°C, 1000hrs, Low profile/Ultra Miniature, 5mm height
- Recommended Applications : AV(TV, Video, Audio), Monitor/Computer, OA/HA/Communication, Small signal
- Corresponding product to RoHS

S5
↑ High Temperature
D5



Specifications

Item	Characteristics							
Operating Temperature Range	-40 ~ +85°C							
Rated Voltage Range	4 ~ 50VDC							
Rated Capacitance Range	1 ~ 220μF							
Capacitance Tolerance	± 20 % at 120Hz , 20°C							
Leakage Current (MAX) (20°C)	I ≤ 0.01CV or 3(μA) , whichever is greater. (After rated voltage applied for 2 minutes) I= Leakage Current (μA) C= Nominal Capacitance (μF) V= Rated Voltage (V)							
Dissipation Factor (MAX) (tanδ) (120Hz ,20°C)	WV	4	6.3	10	16	25	35	50
	tanδ	0.35	0.24	0.20	0.16	0.14	0.12	0.10
Low Temperature Stability Impedance Ratio (MAX)	Z(120Hz)	4	6.3	10	16	25	35	50
	Z(-25°C) / Z(+20°C)	6	4	3	2	2	2	2
	Z(-40°C) / Z(+20°C)	12	8	6	4	4	4	4
Endurance	After applying rated voltage for 1000 hours at 85°C the capacitors shall meet the following requirements.							
	Capacitance Change	Within ± 20 % of initial value						
	Dissipation Factor	Not more than 200% of the specified value						
Shelf Life	After placed at 85°C without voltage applied for 500 hours, the capacitors shall meet the same requirement as Endurance.							

Dimensions

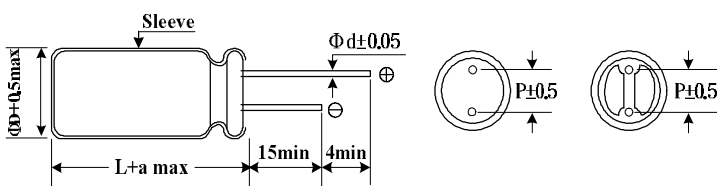

ψD	4	5	6.3
P	1.5	2	2.5
ψd	0.45	0.45	0.45
a	1.0	1.0	1.0

Multiplier for Ripple Current

Frequency coefficient

Freq.(Hz)	50	120	1K	10K
WV(VDC)				
4 ~ 16	0.8	1.0	1.1	1.2
25 ~ 50	0.8	1.0	1.5	1.7

ALUMINUM ELECTROLYTIC CAPACITORS

D5 5mm height
Series

■ Dimensions, Rated Ripple Current

Capacitance (μ F)	Rated (Surge) Voltage													
	4 (5)		6.3 (8)		10 (13)		16 (20)		25 (32)		35 (44)		50 (63)	
	Size	Ripple	Size	Ripple	Size	Ripple	Size	Ripple	Size	Ripple	Size	Ripple	Size	Ripple
1													4x5	10
2.2													4x5	15
3.3													4x5	20
4.7							4x5	10	4x5	15	4x5	20	5x5	25
10			4x5	20	4x5	20	4x5	25	4x5	30	5x5	35	6.3x5	40
22	4x5	25	4x5	30	5x5	30	5x5	35	5x5	40	6.3x5	55	6.3x5	60
33	4x5	30	5x5	35	5x5	40	5x5	45	6.3x5	60				
47	5x5	35	5x5	40	6.3x5	50	6.3x5	60						
100	6.3x5	60	6.3x5	70	6.3x5	75	6.3x5	95						
220	6.3x5	80	6.3x5	95										

☆ Size: D \times L (mm) ☆ Ripple Current : mA/rms, 85 $^{\circ}$ C, 120Hz

ALUMINUM ELECTROLYTIC CAPACITORS

S5 5mm height Series

- Features: 105°C 1000 hours , 5.0mm height
- Recommended Applications: Applicable for VTR , Camera , Car Audio , Miniaudio and other industrial /commercial applications
- Corresponding product to RoHS

S5

↑ High Temperature
D5



Specifications

Item	Characteristics							
Operating Temperature Range	-40 ~ +105°C							
Rated Voltage Range	4 ~ 50VDC							
Rated Capacitance Range	1 ~ 470μF							
Capacitance Tolerance	± 20 % at 120Hz , 20°C							
Leakage Current (MAX) (20°C)	I=0.01CV or 3(μA) , whichever is greater. (After rated voltage applied for 2 minutes)							
Dissipation Factor (MAX) (tanδ) (120Hz ,20°C)	WV	4	6.3	10	16	25	35	50
	tanδ	0.35	0.24	0.20	0.17	0.15	0.12	0.10
Low Temperature Stability Impedance Ratio (MAX)	$\frac{WV}{Z(120Hz)}$	4	6.3	10	16	25	35	50
	$\frac{Z(-25°C)}{Z(+20°C)}$	6	4	3	2	2	2	2
	$\frac{Z(-40°C)}{Z(+20°C)}$	12	8	6	4	4	3	3
Endurance	After apply rated voltage for 1000 hrs at 105°C , the capacitors shall meet the following requirements.							
	Capacitance Change	Within ± 20 % of initial value						
	Dissipation Factor	Not more than 200% of the specified value						
Shelf Life	After placed at 105°C without voltage applied for 500 hours, the capacitors shall meet the same requirement as Endurance.							
	Leakage Current	initial specified value or less						

Dimensions

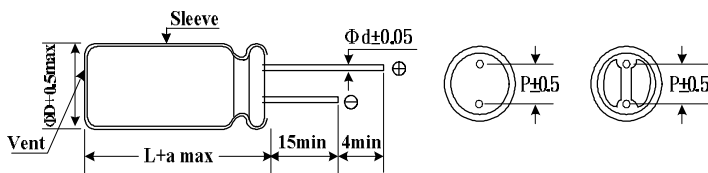

ψD	4.0	5.0	6.3	8.0
P	1.5	2.0	2.5	3.5
ψd	0.45			
a	1.0			

Multiplier for Ripple Current

Frequency coefficient

Frequency (Hz)	120	300	1K	10K
1~47μF	1.00	1.20	1.30	1.50
100~330μF	1.00	1.10	1.15	1.20

ALUMINUM ELECTROLYTIC CAPACITORS

S5

5mm height
Series

■ Dimensions, Rated Ripple Current

Capacitance (μ F)	Rated (Surge) Voltage													
	4 (5)		6.3 (8)		10 (13)		16 (20)		25 (32)		35 (44)		50 (63)	
	Size	Ripple	Size	Ripple	Size	Ripple	Size	Ripple	Size	Ripple	Size	Ripple	Size	Ripple
1.0													4x5	9
2.2													4x5	13
3.3													4x5	17
4.7							4x5	20	4x5	16	4x5	18	4x5	17
													5x5	20
10			4x5	18	4x5	20	4x5	23	4x5	20	5x5	30	6.3x5	33
									5x5	27				
22	4x5	20	4x5	28	5x5	33	4x5	29	6.3x5	42	6.3x5	48	6.3x5	55
							5x5	37						
33	4x5	25	4x5	33	4x5	34	5x5	44	5x5	45				
					5x5	41	6.3x5	49	6.3x5	53				
47	5x5	30	4x5	35	5x5	46	5x5	54	5x5	55				
			5x5	45			6.3x5	58	6.3x5	65				
68					6.3x5	54								
100	6.3x5	50	5x5	55	6.3x5	80	6.3x5	85	8x5	90				
			6.3x5	70										
220	6.3x5	70	6.3x5	90										
330	8x5	110	8x5	115										
470			8x5	100										

☆ Size: D \times L (mm) ☆ Ripple Current: (mA/rms), 105°C, 120Hz

ALUMINUM ELECTROLYTIC CAPACITORS

H5 5mm height Series

- Features: 105°C 2000 hours, Higher temperature range, long life than S5
Low profile/miniature, 5mm height
- Recommended Applications: Monitor/Computer, AV(TV,Video,Audio),
OA/HA/Communication, Small signal
- Corresponding product to RoHS

H5

↑
S5

Long Life



Specifications

Item	Characteristics																								
Operating Temperature Range	-40 ~ +105°C																								
Rated Voltage Range	4 ~ 50VDC																								
Rated Capacitance Range	1 ~ 330μF																								
Capacitance Tolerance	± 20 % at 120Hz, 20°C																								
Leakage Current (MAX) (20°C)	I=0.01CV or 3(μA), whichever is greater. (After rated voltage applied for 2 minutes) I= Leakage Current (μA) C= Nominal Capacitance (μF) V= Rated Voltage (V) (20°C)																								
Dissipation Factor (MAX) (tanδ) (120Hz, 20°C)	<table border="1"> <tr> <td>WV</td> <td>4</td> <td>6.3</td> <td>10</td> <td>16</td> <td>25</td> <td>35</td> <td>50</td> </tr> <tr> <td>tanδ</td> <td>0.37</td> <td>0.26</td> <td>0.24</td> <td>0.20</td> <td>0.16</td> <td>0.13</td> <td>0.12</td> </tr> </table>	WV	4	6.3	10	16	25	35	50	tanδ	0.37	0.26	0.24	0.20	0.16	0.13	0.12								
	WV	4	6.3	10	16	25	35	50																	
tanδ	0.37	0.26	0.24	0.20	0.16	0.13	0.12																		
Down size tanδ add 3%.																									
Low Temperature Stability Impedance Ratio (MAX)	<table border="1"> <tr> <td>Z(120Hz)</td> <td>4</td> <td>6.3</td> <td>10</td> <td>16</td> <td>25</td> <td>35</td> <td>50</td> </tr> <tr> <td>Z-25°C / Z+20°C</td> <td>6</td> <td>4</td> <td>3</td> <td>2</td> <td>2</td> <td>2</td> <td>2</td> </tr> <tr> <td>Z-40°C / Z+20°C</td> <td>12</td> <td>8</td> <td>6</td> <td>4</td> <td>4</td> <td>4</td> <td>4</td> </tr> </table>	Z(120Hz)	4	6.3	10	16	25	35	50	Z-25°C / Z+20°C	6	4	3	2	2	2	2	Z-40°C / Z+20°C	12	8	6	4	4	4	4
	Z(120Hz)	4	6.3	10	16	25	35	50																	
	Z-25°C / Z+20°C	6	4	3	2	2	2	2																	
Z-40°C / Z+20°C	12	8	6	4	4	4	4																		
After applying rated voltage for 2000 hours at 105°C the capacitors shall meet the following requirements.																									
Load Life	<table border="1"> <tr> <td>Capacitance Change</td> <td>Within ± 20 % of initial value</td> </tr> <tr> <td>Dissipation Factor</td> <td>Not more than 200% of the specified value</td> </tr> <tr> <td>Leakage Current</td> <td>initial specified value or less</td> </tr> </table>	Capacitance Change	Within ± 20 % of initial value	Dissipation Factor	Not more than 200% of the specified value	Leakage Current	initial specified value or less																		
	Capacitance Change	Within ± 20 % of initial value																							
	Dissipation Factor	Not more than 200% of the specified value																							
Leakage Current	initial specified value or less																								
Shelf Life	After placed at 105°C without voltage applied for 1000 hours, the capacitors shall meet the same requirement as load life.																								

Diagram of Dimensions

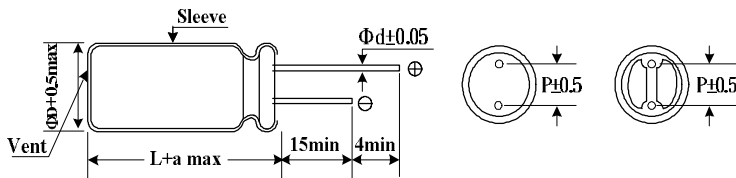

ψD	4.0	5.0	6.3	8.0
P	1.5	2.0	2.5	3.5
ψd	0.45	0.45	0.45	0.45
a	1.0	1.0	1.0	1.0

Multiplier for Ripple Current

Frequency coefficient

WV(VDC)	Freq. (Hz)	50	120	1K	10K
4~16		0.80	1.00	1.10	1.20
25~50		0.80	1.00	1.50	1.70

ALUMINUM ELECTROLYTIC CAPACITORS

H5

5mm height
Series

■ Dimensions, Rated Ripple Current

Capacitance (μ F)	Rated (Surge) Voltage														
	4 (5)		6.3 (8)		10 (13)		16 (20)		25 (32)		35 (44)		50 (63)		
	Size	Ripple	Size	Ripple	Size	Ripple	Size	Ripple	Size	Ripple	Size	Ripple	Size	Ripple	
1.0														4x5	10
2.2														4x5	15
3.3														4x5	15
4.7							4x5	10	4x5	15	4x5	15	5x5	20	
10			4X5	15	4X5	20	4x5	20	4x5	25	5x5	30	6.3X5	35	
22	4X5	20	4X5	25	5X5	25	5x5	30	6.3X5	40	6.3X5	45	6.3X5	55	
33	4X5	25	5X5	30	5X5	35	5x5	40	6.3X5	50					
47	5X5	30	5X5	35	6.3X5	45	6.3X5	55							
100	6.3X5	50	6.3X5	60	6.3X5	70	6.3X5	90							
220	6.3X5	70	8X5	95											
330	8X5	110	8X5	120											

☆ Size: D \times L (mm) ☆ Ripple Current: (mA/rms), 105°C, 120Hz

ALUMINUM ELECTROLYTIC CAPACITORS

D7 7mm/9mm height Series

- Features: 85°C, 1000hrs, Low profile/Miniature, 7mm/9mm height
- Recommended Applications: AV(TV, Video, Audio), Monitor/Computer, OA/HA/Communication, Small signal
- Corresponding product to RoHS

S7
↑ High Temperature
D7

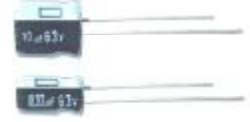

Specifications

Item	Characteristics								
Operating Temperature Range	-40 ~ +85°C								
Rated Voltage Range	4 ~ 63VDC								
Rated Capacitance Range	1 ~ 470μF								
Capacitance Tolerance	± 20 % at 120Hz , 20°C								
Leakage Current (MAX) (20°C)	I ≤ 0.01CV or 3(μA) , whichever is greater. (After rated voltage applied for 2 minutes) I = Leakage Current (μA) C = Nominal Capacitance (μF) V = Rated Voltage (V)								
Dissipation Factor (MAX) (tanδ) (120Hz ,20°C)	WV	4	6.3	10	16	25	35	50	63
	tanδ	0.35	0.24	0.20	0.16	0.14	0.12	0.10	0.08
Low Temperature Stability Impedance Ratio (MAX)	Z(120Hz)	4	6.3	10	16	25	35	50	63
	Z(-25°C) / Z(+20°C)	6	4	3	2	2	2	2	2
	Z(-40°C) / Z(+20°C)	12	8	6	4	4	4	4	4
Endurance	After applying rated voltage for 1000 hours at 85°C the capacitors shall meet the following requirements.								
	Capacitance Change	Within ± 20 % of initial value							
	Dissipation Factor	Not more than 200% of the specified value							
	Leakage Current	Not more than in specified value							
Shelf Life	After placed at 85°C without voltage applied for 500 hours, the capacitors shall meet the same requirement as Endurance.								

Dimensions

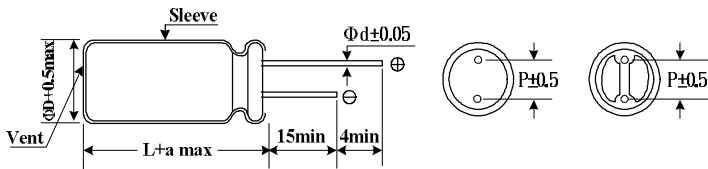

ψD	4	5	6.3	8
P	1.5	2	2.5	3.5
ψd	0.45	0.45	0.45	0.5
a	1.0	1.0	1.0	1.0

Multiplier for Ripple Current

Frequency coefficient

Freq.(Hz)	50	120	1K	10K
WV(VDC)				
4 ~ 16	0.8	1.0	1.1	1.2
25 ~ 35	0.8	1.0	1.5	1.7
50 ~ 63	0.8	1.0	1.6	1.9

ALUMINUM ELECTROLYTIC CAPACITORS

D7 7mm/9mm height
Series

■ Dimensions, Rated Ripple Current

Capacitance (μ F)	Rated (Surge) Voltage											
	4 (5)		6.3 (8)		10 (13)		16 (20)		25 (32)		35 (44)	
	Size	Ripple	Size	Ripple	Size	Ripple	Size	Ripple	Size	Ripple	Size	Ripple
2.2							4x7	10				
3.3							4x7	10				
4.7							4x7	20	4x7	20	4x7	25
10							4x7	30	4x7	35	4x7	40
22					4x7	35	4x7	40	5x7	50	5x7	60
33	4x7	35	4x7	40	4x7	45	4x7	50	5x7	65	6.3x7	75
47	4x7	40	4x7	50	4x7	60	5x7	70	6.3x7	75	6.3x7	80
100	5x7	65	5x7	80	5x7	90	6.3x7	110	8x7	120	8x7	145
220	6.3x7	110	6.3x7	120	6.3x7	135	8x7	180				
330			8x7	170	8x9	170	8x9	230				
470			8x9	230	8x9	240	8x9	280				

Capacitance (μ F)	Rated (Surge) Voltage			
	50 (63)		63 (79)	
	Size	Ripple	Size	Ripple
1	4x7	10	4x7	10
2.2	4x7	20	4x7	20
3.3	4x7	25	4x7	30
4.7	4x7	35	5x7	40
10	5x7	45	6.3x7	55
22	6.3x7	70		
33	8x7	85		
47	8x7	100		

☆ Size: $D \phi \times L$ (mm) ☆ Ripple Current : mA/rms, 85°C, 120Hz

ALUMINUM ELECTROLYTIC CAPACITORS

S7 7mm height Series

- Features : 105°C 1000 hours , 7.0/9.0mm height
- Recommended Applications : For Portable Micro Computer , Disk Driver , Small Calculator and Audio equipment...etc
- Corresponding product to RoHS

S7
 ↑ High Temperature
 D7



Specifications

Item	Characteristics									
Operating Temperature Range	-40 ~ +105°C									
Rated Voltage Range	4 ~ 63VDC									
Rated Capacitance Range	1 ~ 470μF									
Capacitance Tolerance	± 20 % at 120Hz , 20°C									
Leakage Current (MAX) (20°C)	I=0.01CV or 3(μA) , whichever is greater. (After rated voltage applied for 2 minutes)									
Dissipation Factor (MAX) (tanδ) (120Hz ,20°C)	WV	4	6.3	10	16	25	35	50	63	
	tanδ	0.35	0.24	0.20	0.17	0.15	0.12	0.10	0.08	
Low Temperature Stability Impedance Ratio (MAX)	WV	4	6.3	10	16	25	35	50	63	
	Z(120Hz)									
	Z-25°C / Z+20°C	6	4	3	2	2	2	2	2	
	Z-40°C / Z+20°C	12	8	6	4	4	3	3	3	
Endurance	After applying rated voltage for 1000 hours at 105°C the capacitors shall meet the following requirements.									
	Capacitance Change	Within ± 20 % of initial value								
	Dissipation Factor	Not more than 200% of the specified value								
	Leakage Current	initial specified value or less								
Shelf Life	After placed at 105°C without voltage applied for 500 hours, the capacitors shall meet the same requirement as Endurance.									

Diagram of Dimensions

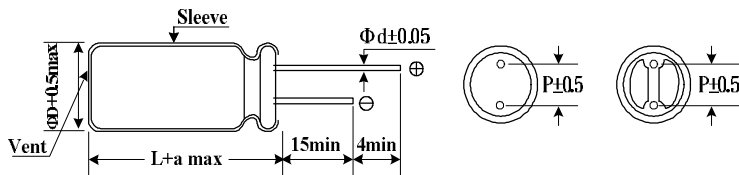

ψD	4.0	5.0	6.3	8.0
P	1.5	2.0	2.5	3.5
ψd	0.45	0.45	0.45	0.5
a	1.0	1.0	1.0	1.0

Multiplier for Ripple Current

Frequency coefficient

Frequency (Hz)	50	120	300	1K	10K
1~47μF	0.75	1.00	1.20	1.30	1.50
100~330μF	0.75	1.00	1.10	1.15	1.20

ALUMINUM ELECTROLYTIC CAPACITORS

S7 7mm height Series

■ Dimensions, Rated Ripple Current

Capacitance (μF)	Rated (Surge) Voltage																
	4 (5)		6.3 (8)		10 (13)		16 (20)		25 (32)		35 (44)		50 (63)		63 (79)		
	Size	Ripple	Size	Ripple	Size	Ripple	Size	Ripple	Size	Ripple	Size	Ripple	Size	Ripple	Size	Ripple	
1.0														4x7	10	4x7	13
2.2							4x7	7						4x7	19	4x7	21
3.3							4x7	13						4x7	24	4x7	26
4.7							4x7	19	4x7	24	4x7	24	4x7	29	4x7	26	
											5x7	24	5x7	31	6.3x7	33	
10							4x7	29	4x7	33	4x7	34	4x7	37	5x7	42	
									5x7	35	5x7	36	5x7	45	6.3x7	50	
									6.3x7	35			6.3x7	45			
22			4x7	37	4x7	31	4x7	36	4x7	43	5x7	48	6.3x7	65			
					5x7	38	5x7	44	5x7	51	6.3x7	57					
									6.3x7	53							
33	4X7	30	5x7	42	4x7	39	4x7	50	5x7	55	6.3x7	70					
					5x7	47	5x7	57	6.3x7	65							
47	4X7	35	4x7	46	4x7	50	5x7	75	5x7	67	6.3x7	81					
			5x7	55	5x7	60	6.3x7	77	6.3x7	79							
					6.3x7	60											
68							5x7	84									
100	5X7	55	5x7	75	5x7	85	5x7	94	6.3x7	120							
			6.3x7	90	6.3x7	100	6.3x7	110	8x7	120							
150							6.3x7	120									
220	6.3X7	95	6.3x7	130	6.3x7	135	8x7	140									
							8x9	140									
330			8x7	140			8x9	155									
470					8x9	165	8x9	165									

☆ Size: Dφx L (mm) ☆ Ripple Current: (mA/rms), 105°C, 120Hz

ALUMINUM ELECTROLYTIC CAPACITORS

H7 7mm/9mm height Series

- Features : 105°C 2000 hours , Higher temperature range, Long life than S7
Low profile/miniature, 7mm/9mm height
- Recommended Applications : Monitor/Computer, AV(TV,Video,Audio),
OA/HA/Communication, Small signal
- Corresponding product to RoHS

H7
↑ Long Life
S7



Specifications

Item	Characteristics																																				
Operating Temperature Range	-40 ~ +105°C																																				
Rated Voltage Range	4 ~ 63VDC																																				
Rated Capacitance Range	1 ~ 470μF																																				
Capacitance Tolerance	± 20 % at 120Hz , 20°C																																				
Leakage Current (MAX) (20°C)	I=0.01CV or 3(μA) , whichever is greater. (After rated voltage applied for 2 minutes) I= Leakage Current (μA) C= Nominal Capacitance (μF) V= Rated Voltage (V) (20°C)																																				
Dissipation Factor (MAX) (tanδ) (120Hz ,20°C)	<table border="1"> <thead> <tr> <th>WV</th> <th>4</th> <th>6.3</th> <th>10</th> <th>16</th> <th>25</th> <th>35</th> <th>50</th> <th>63</th> </tr> </thead> <tbody> <tr> <td>tanδ</td> <td>0.35</td> <td>0.24</td> <td>0.20</td> <td>0.18</td> <td>0.15</td> <td>0.13</td> <td>0.12</td> <td>0.10</td> </tr> </tbody> </table> <p>Down size tanδ add 3%.</p>	WV	4	6.3	10	16	25	35	50	63	tanδ	0.35	0.24	0.20	0.18	0.15	0.13	0.12	0.10																		
WV	4	6.3	10	16	25	35	50	63																													
tanδ	0.35	0.24	0.20	0.18	0.15	0.13	0.12	0.10																													
Low Temperature Stability Impedance Ratio (MAX)	<table border="1"> <thead> <tr> <th>WV</th> <th>4</th> <th>6.3</th> <th>10</th> <th>16</th> <th>25</th> <th>35</th> <th>50</th> <th>63</th> </tr> </thead> <tbody> <tr> <td>Z(120Hz)</td> <td></td> <td></td> <td></td> <td></td> <td></td> <td></td> <td></td> <td></td> </tr> <tr> <td>Z-25°C / Z+20°C</td> <td>6</td> <td>4</td> <td>3</td> <td>2</td> <td>2</td> <td>2</td> <td>2</td> <td>2</td> </tr> <tr> <td>Z-40°C / Z+20°C</td> <td>12</td> <td>8</td> <td>6</td> <td>4</td> <td>4</td> <td>4</td> <td>4</td> <td>4</td> </tr> </tbody> </table>	WV	4	6.3	10	16	25	35	50	63	Z(120Hz)									Z-25°C / Z+20°C	6	4	3	2	2	2	2	2	Z-40°C / Z+20°C	12	8	6	4	4	4	4	4
WV	4	6.3	10	16	25	35	50	63																													
Z(120Hz)																																					
Z-25°C / Z+20°C	6	4	3	2	2	2	2	2																													
Z-40°C / Z+20°C	12	8	6	4	4	4	4	4																													
Load Life	<p>After applying rated voltage for 2000 hours at 105°C the capacitors shall meet the following requirements.</p> <table border="1"> <tbody> <tr> <td>Capacitance Change</td> <td>Within ± 20 % of initial value</td> </tr> <tr> <td>Dissipation Factor</td> <td>Not more than 200% of the specified value</td> </tr> <tr> <td>Leakage Current</td> <td>initial specified value or less</td> </tr> </tbody> </table>	Capacitance Change	Within ± 20 % of initial value	Dissipation Factor	Not more than 200% of the specified value	Leakage Current	initial specified value or less																														
Capacitance Change	Within ± 20 % of initial value																																				
Dissipation Factor	Not more than 200% of the specified value																																				
Leakage Current	initial specified value or less																																				
Shelf Life	After placed at 105°C without voltage applied for 1000 hours, the capacitors shall meet the same requirement as load life.																																				

Diagram of Dimensions

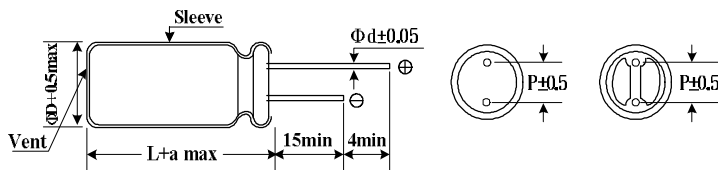

ψD	4.0	5.0	6.3	8.0
P	1.5	2.0	2.5	3.5
ψd	0.45	0.45	0.45	0.5
a	1.0	1.0	1.0	1.0

Multiplier for Ripple Current

Frequency coefficient

WV(VDC)	50	120	1K	10K
4~16	0.8	1.0	1.1	1.2
25~35	0.8	1.0	1.5	1.7
50~63	0.8	1.0	1.6	1.9

ALUMINUM ELECTROLYTIC CAPACITORS

H7 7mm/9mm height
Series

■ Dimensions, Rated Ripple Current

Capacitance (μ F)	Rated (Surge) Voltage																
	4 (5)		6.3 (8)		10 (13)		16 (20)		25 (32)		35 (44)		50 (63)		63 (79)		
	Size	Ripple	Size	Ripple	Size	Ripple	Size	Ripple	Size	Ripple	Size	Ripple	Size	Ripple	Size	Ripple	
1.0														4x7	10	4x7	10
2.2							4x7	10						4x7	20	4x7	20
3.3							4x7	10						4x7	25	4x7	25
4.7							4x7	15	4x7	20	4x7	25	4x7	30	5x7	35	
10							4x7	25	4x7	30	4x7	35	5x7	35	6.3x7	50	
22					4x7	30	4x7	35	5x7	50	5x7	60	6.3x7	65			
33	4X7	30	4x7	35	4x7	40	5x7	50	6.3x7	65	6.3x7	70	8x7	80			
47	4X7	35	5x7	50	5x7	60	6.3x7	70	6.3x7	70	8x7	80	8x9	100			
100	5X7	55	5x7	70	6.3x7	90	6.3x7	110	8x7	115	8x9	145					
220	6.3X7	95	6.3x7	110	6.3x7	135	8x9	180									
330			8x7	150	8x9	160	8x9	210									
470			8x9	200	8x9	210											

☆ Size: D ψ x L (mm) ☆ Ripple Current: (mA/rms), 105°C, 120Hz

ALUMINUM ELECTROLYTIC CAPACITORS

RN Non-polar Series



- Features: 85°C, 1000hrs, Non-polarized/Polarity reversing
- Recommended Applications:
Small crossover network, Reversed polarity circuit, Coupling
- Corresponding product to RoHS

Specifications

Item	Characteristics													
Operating Temperature Range	-40 ~ +85°C							-25~+85°C						
Rated Voltage Range	4 ~ 100VDC							160~250VDC						
Rated Capacitance Range	1 ~ 6800µF							1~100µF						
Capacitance Tolerance	± 20 % at 120Hz , 20°C													
Leakage Current (MAX) (20°C)	$I \leq 0.03CV + 4\mu A$; $L=7mm, I \leq 0.05CV$ or $10\mu A$ whichever is greater (After rated voltage applied for 2 minutes) $I =$ Leakage Current (μA) $C =$ Nominal Capacitance (μF) $V =$ Rated Voltage (V)													
Dissipation Factor (MAX) (tanδ) (120Hz ,20°C)	WV	4	6.3	10	16	25	35	50	63	80	100	160	200	250
	tanδ	0.35	0.24	0.2	0.17	0.15	0.15	0.15	0.10	0.10	0.10	0.20	0.20	0.20
When nominal capacitance is over 1000µF tanδ shall be added 0.02 to the listed value with increase of every 1000µF.														
Low Temperature Stability Impedance Ratio (MAX)	WV	4	6.3	10	16	25	35	50	63	80	100	160	200	250
	Z(120Hz)	4	6.3	10	16	25	35	50	63	80	100	160	200	250
	Z(-25°C) / Z(+20°C)	6	4	3	2	2	2	2	2	2	2	6	6	6
	Z(-40°C) / Z(+20°C)	12	8	6	4	4	3	3	3	3	3	-	-	-
Endurance	After applying rated voltage for 1000 hours at 85°C, the capacitors shall meet the following requirements. (The polarity shall be reversed every 250 hours)													
	Capacitance Change	Within ± 20 % of initial value												
	Dissipation Factor	Not more than 200% of the specified value												
	Leakage Current	Not more than the specified value												
Shelf Life	After placed at 85°C without voltage applied for 500 hours, the capacitors shall meet the same requirements as load life.													

Diagram of Dimensions

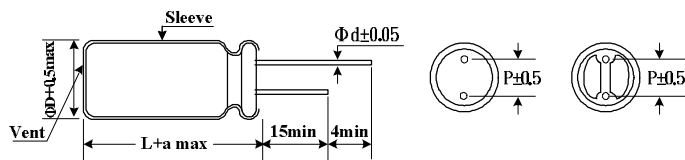

ψD	4	5	6.3	8	10	13	16	18
P	1.5	2.0	2.5	3.5	5.0	5.0	7.5	7.5
ψd	0.45	(0.45) 0.5	(0.45) 0.5	0.6	0.6	0.6	0.8	0.8
a	1.0	(1.0) 1.5	(1.0) 1.5	1.5	1.5	2.0	2.0	2.0

() : L = 7

Multiplier for Ripple Current

Frequency coefficient

Freq.(Hz)	50	120	1K	10K
WV(VDC)				
4 ~ 16	0.8	1.0	1.1	1.2
25 ~35	0.8	1.0	1.5	1.7
50 ~ 100	0.8	1.0	1.6	1.9
160 ~ 250	0.8	1.0	1.5	1.6

ALUMINUM ELECTROLYTIC CAPACITORS

RN Non-polar Series

■ Dimensions, Rated Ripple Current

Capacitance (μF)	Rated (Surge) Voltage																
	4 (5)		6.3 (8)		10 (13)		16 (20)		25 (32)		35 (44)		50 (63)		63 (79)		
	Size	Ripple	Size	Ripple	Size	Ripple	Size	Ripple	Size	Ripple	Size	Ripple	Size	Ripple	Size	Ripple	
1.0														4x7	10	4x7	15
														5x11	10	5x11	10
2.2												4x7	15	4x7	20	5x7	25
														5x11	20	5x11	20
3.3										4x7	15	5x7	20	5x7	25	6.3x7	30
														5x11	30	5x11	30
4.7												5x7	25	6.3x7	30	6.3x7	35
							4x7	20	5x7	20	5x11	30	5x11	30	6.3x11	35	
10							5x7	30	5x11	40	5x11	40					
					4x7	25	5x11	40	6.3x7	35	6.3x7	40	6.3x11	45	6.3x11	55	
22					5x7	40	5x11	55	6.3x7	50							
			5x7	35	5x11	50	6.3x7	45	6.3x11	65	6.3x11	70	8x11	80	8x11	90	
33	5x7	35	5x7	40	5x11	65	5x11	70	6.3x7	65							
			5x11	60	6.3x7	50	6.3x7	60	6.3x11	80	8x11	100	8x11	105	10x12.5	135	
47			5x11	70	5x11	75	6.3x7	70									
	5x7	40	6.3x7	50	6.3x7	60	6.3x11	95	6.3x11	95	8x11	120	8x15	140	10x16	180	
100	6.3x7	60	6.3x11	115	6.3x11	125	8x11	160	8x11	160	10x16	230	10x20	265	13x20	320	
220			8x11	205	8x11	215	10x12.5	275	10x16	305	13x20	410	13x25	480	16x25	575	
330			8x11	265	10x16	345	10x16	375	13x20	450	13x20	505	16x25	650	16x32	750	
470			10x12.5	370	10x16	410	10x20	485	13x20	540	13x25	655	16x32	835	18x36	965	
1000			10x20	650	13x20	720	13x25	855	16x25	950	16x32	1140					
2200			13x25	1160	16x25	1280	16x32	1510	18x36	1620							
3300			16x25	1570	16x32	1690	18x36	1980									
4700			16x32	2020	18x36	2160											
6800			18x36	2600													

Capacitance (μF)	Rated (Surge) Voltage									
	80 (100)		100 (125)		160 (200)		200 (250)		250 (300)	
	Size	Ripple	Size	Ripple	Size	Ripple	Size	Ripple	Size	Ripple
1			5x11	10	6.3x11	15	6.3x11	15	8x11	15
2.2	5x11	30	6.3x11	25	8x11	20	8x11	20	10x12.5	25
3.3	6.3x11	35	6.3x11	35	10x12.5	30	10x12.5	30	10x12.5	30
4.7	6.3x11	40	6.3x11	40	10x12.5	35	10x16	40	10x16	40
10	8x11	65	8x11	70	10x16	55	13x20	70	13x20	70
22	10x16	105	10x16	135	13x25	105	13x25	120	16x25	135
33	10x16	160	13x20	220	16x25	165	16x25	165	16x32	180
47	10x20	215	13x20	240	16x26	200	16x32	220	16x36	230
100	13x25	385	16x25	425	18x36	360				
220	16x32	690	18x36	720						
330	18x36	860								

☆ Size: Dψx L (mm) ☆ Ripple Current : mArms/85°C, 120Hz

ALUMINUM ELECTROLYTIC CAPACITORS

SN Non-polar Series

- Features: 105°C 1000 hours
 - Recommended Application: Non-polar miniature type for used in reversing polarity DC voltage circuits
 - Corresponding product to RoHS
- SN**
↑ High Temperature
RN

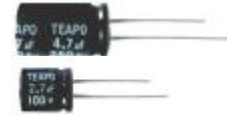

Specifications

Item	Characteristics	
Operating Temperature Range	-40 ~ +105°C	-25~+105°C
Rated Voltage Range	6.3 ~ 100VDC	160~250VDC
Rated Capacitance Range	1 ~ 2200 µF	1~100µF
Capacitance Tolerance	± 20 % at 120Hz , 20°C	
Leakage Current (MAX) (20°C)	I=0.03CV+ 3µA; L=7mm, I=0.06CV+ 10µA(After rated voltage applied for 2 minutes)	
Dissipation Factor (MAX) (tanδ) (120Hz ,20°C)	WV	6.3 10 16 25 35 50 63 80 100 160 200 250
	tanδ	0.24 0.20 0.17 0.15 0.15 0.15 0.10 0.10 0.10 0.20 0.20 0.20
When nominal capacitance is over 1000uF · tanδ shall be added 0.02 to the listed value with increase of every 1000uF;L=7mm, tanδ shall be added 0.03		
Low Temperature Stability Impedance Ratio (MAX)	WV	6.3 10 16 25 35 50 63 80 100 160-250
	Z(120Hz)	
	Z-25°C / Z+20°C	4 3 2 2 2 2 2 2 2 6
Z-40°C / Z+20°C	10 8 6 4 3 3 3 3 3 -	
Endurance	After applying rated voltage for 1000 hours at 105°C , (The polarity shall be reversed every 250 hrs.)	
	Capacitance Change	Within ± 25 % of initial value
	Dissipation Factor	Not more than 200% of specified value
Shelf Life	After placed at 105°C without voltage applied for 500 hours, the capacitors shall meet the same requirement as Endurance.	
	Leakage Current	Not more than the specified value

Diagram of Dimensions

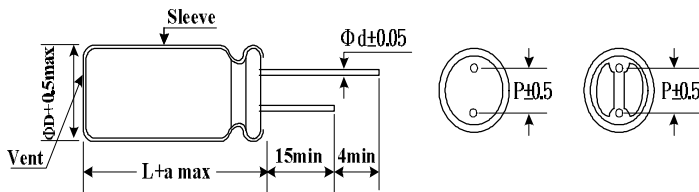

ψD	4.0	5.0	6.3	8.0	10.0	13.0	16.0	18.0
P	1.5	2.0	2.5	3.5	5.0	5.0	7.5	7.5
ψd	0.45	0.5	0.5	0.6	0.6	0.6	0.8	0.8
a	1.0	1.5	1.5	1.5	1.5	2.0	2.0	2.0

Multiplier for Ripple Current

Frequency coefficient

Frequency (Hz)	60	120	300	1K	10K
Factor	0.75	1.00	1.20	1.32	1.65

ALUMINUM ELECTROLYTIC CAPACITORS

SN Non-polar Series

■ Dimensions, Rated Ripple Current

Capacitance (μF)	Rated (Surge) Voltage																	
	6.3(8)		10(13)		16(20)		25(32)		35(44)		50(63)		63(79)		80(100)		100(125)	
	SIZE	R.C	SIZE	R.C	SIZE	R.C	SIZE	R.C	SIZE	R.C	SIZE	R.C	SIZE	R.C	SIZE	R.C	SIZE	R.C
1											5x11	17	5x11	17	5x11	17	5x11	21
2.2											5x11	25	5x11	25	5x11	29	6.3x11	34
3.3											6.3x11	31	6.3x11	37	6.3x11	39	8x11	49
4.7									5x11	34	5x11	34	5x11	37	8x11	47	8x11	58
											6.3x11	41	6.3x11	44				
10					6.3x11	45	5x11	42	6.3x11	54	6.3x11	56	8x11	74	10x12.5	88	8x11	80
							6.3x11	50			8x11	70					10x12.5	100
22			5x11	57	5x11	59	6.3x11	69	8x11	94	6.3x11	75	8x11	95	10x20	150	13x20	180
					6.3x11	69	8x11	86			8x11	97	10x16	130				
33											10x12.5	115						
	5x11	63	6.3x11	77	8x11	98	8x11	105	10x12.5	125	8x11	110	8x11	115	13x20	205	13x20	220
47											10x16	150	10x20	175				
	6.3x11	84	6.3x11	93	8x11	115	10x12.5	140	10x16	165	8x11	130	13x20	230	13x20	245	13x25	285
100											10x20	190						
	8x11	140	8x11	193	8x11	140	10x20	240	13x20	285	13x20	310	16x25	410	16x25	435	16x32	510
					10x12.5	175												
				10x16	205													
220	10x12.5	235	10x16	255	10x20	330	13x20	390	16x25	520	16x25	570	16x32	660				
330	10x16	310	10x20	380	13x20	445	16x25	580	16x25	630	16x36	790						
470	10x20	400	13x20	470	13x25	570	16x25	690	16x32	820								
1000	13x25	690	16x25	885	16x32	1020												
2200	16x32	1250	16x36	1450														

☆ Size: D \times L (mm) ☆ Ripple Current: (mA/rms), 105°C, 120Hz

Capacitance (μF)	Rated (Surge) Voltage					
	160(200)		200(250)		250(300)	
	SIZE	R.C	SIZE	R.C	SIZE	R.C
1	6.3x11	21	6.3x11	21	8x11	25
2.2	8x11	34	8x11	34	10x12.5	38
3.3	10x12.5	49	10x12.5	49	10x12.5	49
4.7	10x12.5	58	10x15	62	10x17	66
10	10x17	80	13x20	100	13x20	100
22	13x25	180	13x25	180	16x26	200
33	16x26	220	16x26	220	16x32	250
47	16x26	285	16x32	315	16x36	330
100	18x36	510				

ALUMINUM ELECTROLYTIC CAPACITORS

RB Non-Polar Series



- Features: 85°C, 1000hrs, Non-polarized/Polarity reversing, High ripple current
- Recommended Applications: Crossover/Speaker network, Reversed polarity circuit
- Corresponding product to RoHS

Specifications

Item	Characteristics						
Operating Temperature Range	-40 ~ +85°C						
Rated Voltage Range	25 ~ 100VDC						
Rated Capacitance Range	1 ~ 100µF						
Capacitance Tolerance	± 10 % at 1KHz, 20°C						
Leakage Current (MAX) (20°C)	$I \leq 0.03CV$ or $3\mu A$ whichever is greater (After rated voltage applied for 2 minutes) I= Leakage Current (µA) C= Nominal Capacitance (µF) V= Rated Voltage (V)						
Dissipation Factor (MAX) (tanδ) (120Hz, 20°C)	WV	25	35	50	63	80	100
	tanδ	0.17	0.15	0.15	0.12	0.10	0.10
Endurance	After applying rated voltage for 1000 hours at 85°C, the capacitors shall meet the following requirements. (The polarity shall be reversed every 250 hours)						
	Capacitance Change	Within ± 20 % of the initial value					
	Dissipation Factor	Not more than 200% of the specified value					
	Leakage Current	Not more than the specified value					
Shelf Life	After placed at 85°C without voltage applied for 500 hours, the capacitors shall meet the same requirement as Endurance.						

Dimensions

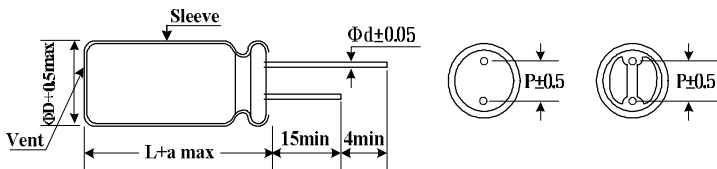

ψD	5	6.3	8	10	13	16	18
P	2.0	2.5	3.5	5.0	5.0	7.5	7.5
ψd	0.5	0.5	0.6	0.6	0.6	0.8	0.8
a	1.5	1.5	1.5	1.5	2.0	2.0	2.0

Multiplier for Ripple Current

Frequency coefficient

WV(VDC)	Freq.(Hz)	50	120	1K	10K	100K
25 ~ 35		0.8	0.9	1.0	1.6	1.8
50 ~ 100		0.8	0.9	1.0	1.7	2.0

ALUMINUM ELECTROLYTIC CAPACITORS

RB Non-Polar Series

■ Dimensions, Rated Ripple Current

Capacitance (μ F)	Rated (Surge) Voltage											
	25 (32)		35 (44)		50 (63)		63 (79)		80 (100)		100 (125)	
	Size	Ripple	Size	Ripple	Size	Ripple	Size	Ripple	Size	Ripple	Size	Ripple
1											6.3x11	70
1.5											6.3x11	85
2.2									6.3x11	95	8x11	110
3.3							6.3x11	105	8x11	130	8x11	140
4.7							8x11	145	8x11	155	10x12.5	200
5.6					6.3x11	130	8x11	160	10x12.5	200	10x12.5	215
6.8					8x11	170	8x11	180	10x12.5	220	10x12.5	235
8.2					8x11	185	8x11	195	10x12.5	245	10x16	290
10			6.3x11	170	8x11	205	10x12.5	255	10x12.5	270	10x16	320
15	6.3x11	200	8x11	240	10x12.5	295	10x12.5	310	10x16	390	10x20	445
22	8x11	280	10x12.5	340	10x12.5	360	10x16	420	10x20	505	13x20	625
33	8x11	340	10x12.5	420	10x16	515	10x20	580	13x20	720	13x25	845
47	10x12.5	480	10x16	555	10x20	660	13x20	805	13x25	945	16x25	1155
56	10x12.5	520	10x16	640	13x20	835	13x20	880	13x25	1030	16x25	1260
68	10x16	635	10x16	705	13x20	920	13x25	1070	16x25	1300	16x32	1520
82	10x16	700	10x20	830	13x20	1010	13x25	1175	16x25	1430	16x36	1765
100	10x16	820	13x20	1065	13x25	1230	16x36	1480	16x36	1820	18x36	2080

☆ Size: D \times L (mm) ☆ Ripple Current : mA/rms, 85°C, 1KHz

ALUMINUM ELECTROLYTIC CAPACITORS

SR

Bi-polar horizontal deflection
Series

- Features: 85°C 1000 hours
- Recommended Application: Non-polar capacitors for horizontal deflection circuits of TV sets, Correction at high frequency and high ripple currents
- Corresponding product to RoHS



Specifications

Item	Characteristics			
Operating Temperature Range	-40 ~ +85°C			
Rated Voltage Range	25~ 50VDC			
Rated Capacitance Range	2.2 ~ 47 μ F			
Capacitance Tolerance	$\pm 10 \%$ (K) at 120Hz , 20°C			
Leakage Current (MAX) (20°C)	DC Leakage current : 100 μ A Max .(After 2 minutes both direction)			
Dissipation Factor (MAX) (tan δ) (120Hz ,20°C)	WV	25	35	50
	tan δ	0.05	0.05	0.05
Endurance	After applying rated voltage for 1000hrs at 85°C , (Polarity inverted every 250 hrs.) the capacitors shall meet the following requirements.			
	Capacitance Change	Within $\pm 20 \%$ of initial value		
	Dissipation Factor	Not more than 150% of specified value		
Shelf Life	After placed at 85°C without voltage applied for 500 hours, the capacitors shall meet the same requirement as Endurance.			
	Leakage Current	Not more than the specified value		

Diagram of Dimensions

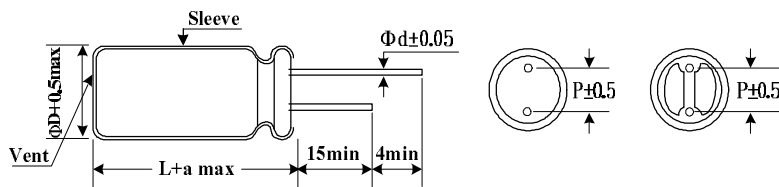

ψ D	13.0	16.0	18.0	22.0
P	5.0	7.5	10.0	
ψ d	0.6	0.8	0.8	
a	2.0			

Multiplier for Ripple Current

Frequency coefficient

Frequency (Hz)	60	120	400 ~ 1 K	15.75 K
25~50 V	0.4	0.4	0.8	1.0

ALUMINUM ELECTROLYTIC CAPACITORS

SR

Bi-polar horizontal deflection
Series

■ Dimensions, Rated Ripple Current

Capacitance (μ F)	Rated (Surge) Voltage					
	25 (32)		35 (44)		50 (63)	
	SIZE	RIPPLE	SIZE	RIPPLE	SIZE	RIPPLE
2.2	16X25	6	16X25	6	16X25	6
3.3	16X25	7	16X25	7	16X25	7
4.7	16X25	7	16X25	7	16X25	7
5.6	16X32	7	16X32	7	16X32	7
6.8	16X36	8	16X36	8	16X36	8
8.2	16X36	8	16X36	8	16X36	8
10	18X40	12	18X40	12	18X40	12
13	18X40	12	18X40	12	18X40	12
15	18X40	12	18X40	12	18X40	12
18	22X40	13	22X40	13	22X40	13
20	22X40	13	22X40	13	22X40	13
22	22X40	13	22X40	13	22X40	13
25	22X40	13	22X40	13	22X40	13
47	22X40	13	22X40	13	22X40	13

☆ Size: D \times L (mm) ☆ Ripple Current: (Ap-p) / Sawtooth waveform 15.75KHz, 85°C

ALUMINUM ELECTROLYTIC CAPACITORS

BX Bi-Polar Series

- Features: 105°C, 1000hrs, Bi-polarized/Polarity reversing
- Recommended Applications: TV/Monitor, Horizontal deflection correction
- Corresponding product to RoHS

BX
↑
SR High Temperature



Specifications

Item	Characteristics			
Operating Temperature Range	-40 ~ +105°C			
Rated Voltage Range	25 ~ 50VDC			
Rated Capacitance Range	1 ~ 33 µF			
Capacitance Tolerance	± 10 % (K) at 120Hz , 20°C			
Leakage Current (MAX) (20°C)	I ≤ 100µA (After rated voltage applied for 2 minutes) I = Leakage Current (µA)			
Dissipation Factor (MAX) (tanδ) (120Hz ,20°C)	WV	25	35	50
	tanδ	0.05	0.05	0.05
Endurance	After applying rated voltage for 1000 hours at 105°C, the capacitors shall meet the following requirements. (The polarity shall be reversed every 250 hours)			
	Capacitance Change	Within ± 15 % of the initial value		
	Dissipation Factor	Not more than 200% of the specified value		
	Leakage Current	Not more than the specified value		
Shelf Life	After placed at 105°C without voltage applied for 500 hours, the capacitor shall meet the same requirement as Endurance			

Dimensions

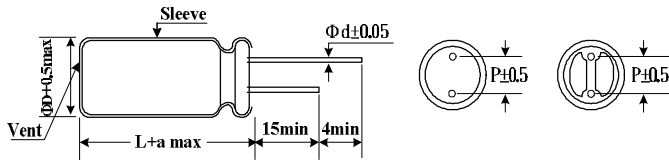

ψD	10	13	16	18	22	25
P	5.0	5.0	7.5	7.5	10.0	12.5
ψd	0.6	0.6	0.8	0.8	0.8	1.0
a	1.5	2.0	2.0	2.0	2.0	2.0

Multiplier for Ripple Current

Frequency coefficient

Frequency (Hz)	60	120	400 ~ 1 K	15.75 K
25~50 V	0.4	0.4	0.8	1.0

ALUMINUM ELECTROLYTIC CAPACITORS

BX Bi-Polar Series

■ Dimensions, Rated Ripple Current, Equivalent Series Resistance

Capacitance (μF)	Rated (Surge) Voltage								
	25 (32)			35 (44)			50 (63)		
	Size	Ripple	ESR	Size	Ripple	ESR	Size	Ripple	ESR
1							10x20	1.4	66.4
1.2				10x20	1.5	55.3	13x20	1.8	55.3
1.5				10x20	1.8	44.3	13x20	2.0	44.3
1.8	10x20	1.9	36.9	13x20	2.2	36.9	13x20	2.2	36.9
2.2	13x20	2.5	30.2	13x20	2.5	30.2	13x20	2.5	30.2
2.7	13x20	2.7	24.6	13x20	2.7	24.6	13x25	3.0	24.6
3.3	13x20	3.1	20.1	13x25	3.3	20.1	16x25	3.8	20.1
3.9	13x20	3.3	17	13x25	3.6	17	16x25	4.0	17.0
4.7	13x25	4.0	14.1	16x25	4.5	14.1	16x25	4.5	14.1
5.6	16x25	5.0	11.9	16x25	5.0	11.9	16x32	5.4	11.9
6.8	16x25	5.5	9.76	16x32	6.0	9.76	16x36	6.8	9.76
8.2	16x25	6.0	8.09	16x32	6.5	8.09	18x36	7.4	8.10
10	16x32	7.3	6.64	16x36	7.6	6.64	18x40	8.5	6.64
12	16x36	8.5	5.53	18x36	8.5	5.53	22x40	9.3	5.53
15	18x36	9.3	4.43	18x40	10	4.43	22x40	11	4.43
18	18x40	11	3.69	22x40	12	3.69	25x40	14	3.69
22	22x40	13	3.02	22x40	14	3.02	25x40	15	3.02
27	22x40	15	2.46	25x40	16	2.46			
33	25x40	18	2.01						

☆ Size: D \times L (mm) ☆ Max Ripple Current [RC(Ap-p) / Sawtooth waveform 15.75KHz, 105°C] ☆ ESR:(Ω), 120Hz, 20°C

ALUMINUM ELECTROLYTIC CAPACITORS

SB

Low leakage current
Series

- Features: 105°C 1000 hours
- Recommended Applications:
in where low leakage current is essential as in coupling of pre-amplifiers
Remaining of very low leakage current even after prolonged storage
- Corresponding product to RoHS



Specifications

Item	Characteristics																																																	
Operating Temperature Range	-40 ~ +105°C																																																	
Rated Voltage Range	6.3 ~ 100VDC																																																	
Rated Capacitance Range	1 ~ 15000 µF																																																	
Capacitance Tolerance	± 20 % at 120Hz , 20°C																																																	
Leakage Current (MAX) (20°C)	$I=0.002CV$ or $0.4 \mu A$,whichever is greater. (After rated voltage applied for 2 minutes)																																																	
Dissipation Factor (MAX) (tanδ) (120Hz ,20°C)	<table border="1"> <thead> <tr> <th>WV</th> <th>6.3</th> <th>10</th> <th>16</th> <th>25</th> <th>35</th> <th>50</th> <th>63</th> <th>80</th> <th>100</th> </tr> </thead> <tbody> <tr> <td>tanδ</td> <td>0.28</td> <td>0.24</td> <td>0.20</td> <td>0.16</td> <td>0.14</td> <td>0.12</td> <td>0.10</td> <td>0.10</td> <td>0.10</td> </tr> </tbody> </table>	WV	6.3	10	16	25	35	50	63	80	100	tanδ	0.28	0.24	0.20	0.16	0.14	0.12	0.10	0.10	0.10																													
	WV	6.3	10	16	25	35	50	63	80	100																																								
tanδ	0.28	0.24	0.20	0.16	0.14	0.12	0.10	0.10	0.10																																									
When nominal capacitance is over 1000µF, tanδshall be added 0.02 to the listed value with increase of every 1000µF.																																																		
Low Temperature Stability Impedance Ratio (MAX)	<table border="1"> <thead> <tr> <th>WV</th> <th>6.3</th> <th>10</th> <th>16</th> <th>25</th> <th>35</th> <th>50</th> <th>63</th> <th>80</th> <th>100</th> </tr> </thead> <tbody> <tr> <td>Z(120Hz)</td> <td></td> <td></td> <td></td> <td></td> <td></td> <td></td> <td></td> <td></td> <td></td> </tr> <tr> <td>Z(-25°C)/ Z(+20°C)</td> <td>4</td> <td>3</td> <td>2</td> <td>2</td> <td>2</td> <td>2</td> <td>2</td> <td>1.5</td> <td>1.5</td> </tr> <tr> <td>Z(-40°C)/ Z(+20°C)</td> <td>8</td> <td>6</td> <td>4</td> <td>4</td> <td>3</td> <td>3</td> <td>3</td> <td>2</td> <td>2</td> </tr> </tbody> </table>	WV	6.3	10	16	25	35	50	63	80	100	Z(120Hz)										Z(-25°C)/ Z(+20°C)	4	3	2	2	2	2	2	1.5	1.5	Z(-40°C)/ Z(+20°C)	8	6	4	4	3	3	3	2	2									
	WV	6.3	10	16	25	35	50	63	80	100																																								
	Z(120Hz)																																																	
Z(-25°C)/ Z(+20°C)	4	3	2	2	2	2	2	1.5	1.5																																									
Z(-40°C)/ Z(+20°C)	8	6	4	4	3	3	3	2	2																																									
After applying rated voltage for 1000 hours at 105°C , the capacitors shall meet the following requirements.																																																		
Endurance	Capacitance Change	Within ± 25 % of initial value																																																
	Dissipation Factor	Not more than 200% of specified value																																																
	Leakage Current	Not more than the specified value																																																
Shelf Life	After 500 hrs at 105°C without applying rated voltage																																																	
	Capacitance Change	Within ± 25 % of initial value																																																
	Leakage Current	Not more than 200% of specified value																																																

Diagram of Dimensions

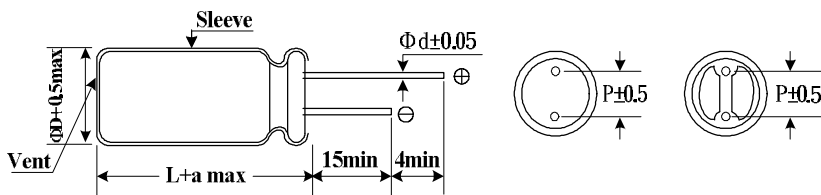

ψD	5	6.3	8	10	13	16	18	22
P	2	2.5	3.5	5	5	7.5	7.5	10
ψd	0.5	0.5	0.6	0.6	0.6	0.8	0.8	0.8
a	1.5	1.5	1.5	1.5	2.0	2.0	2.0	2.0

Multiplier for Ripple Current

Frequency coefficient

Frequency (Hz)	50	120	300	1K	10K
6.3 ~ 25 V	0.85	1.00	1.04	1.08	1.19
35~ 50 V	0.80	1.00	1.30	1.40	1.43
63 ~ 100 V	0.77	1.00	1.34	1.43	1.48

ALUMINUM ELECTROLYTIC CAPACITORS

SB

Low leakage current
Series

■ Dimensions, Rated Ripple Current

Capacitance (μF)	Rated (Surge) Voltage					
	6.3V (8)		10V (13)		16V (20)	
	SIZE	Ripple	SIZE	Ripple	SIZE	Ripple
1						
2.2						
3.3						
4.7						
10					5x11	40
22			5x11	50	5x11	55
33	5x11	55	5x11	60	5x11	70
47	5x11	65	5x11	75	5x11	85
100	5x11	95	5x11	110	6.3x11	140
220	6.3x11	165	6.3x11	180	8x11	230
330	6.3x11	195	8x11	250	8x11	280
470	8x11	270	8x11	300	10x12.5	400
1000	10x12.5	465	10x17	600	10x17	660
2200	13x20	925	13x20	1000	13x25	1210
3300	13x20	1100	13x25	1300	16x26	1610
4700	16x26	1600	16x26	1700	16x32	2020
6800	16x26	1810	16x32	2100	18x36	2520
10000	16x32	2210	18x36	2630	18x40	2910
15000	18x36	2760				

☆ Size: Dφx L (mm) ☆ Ripple Current: (mA/rms). 105°C, 120Hz

ALUMINUM ELECTROLYTIC CAPACITORS

SB

Low leakage current
Series

■ Dimensions, Rated Ripple Current

Capacitance (μF)	Rated (Surge) Voltage					
	25V (32)		35V (44)		50V (63)	
	SIZE	Ripple	SIZE	Ripple	SIZE	Ripple
1					5x11	10
2.2					5x11	20
3.3					5x11	30
4.7	5x11	30	5x11	35	5x11	35
10	5x11	40	5x11	45	5x11	55
22	5x11	60	5x11	65	5x11	75
33	5x11	75	5x11	80	6.3x11	100
47	5x11	90	6.3x11	110	6.3x11	120
100	6.3x11	140	8x11	180	8x11	200
220	8x11	250	10x12.5	320	10x17	400
330	10x12.5	360	10x17	450	10x20	520
470	10x17	490	10x20	570	13x20	730
1000	13x20	880	13x25	1060	16x26	1330
2200	16x26	1550	16x32	1700	18x36	2100
3300	16x32	1860	18x36	2200		
4700	18x36	2380	18x40	2610		
6800	18x40	2770				
10000						
15000						

☆ Size: D φ x L (mm) ☆ Ripple Current: (mA/rms). 105°C, 120Hz

ALUMINUM ELECTROLYTIC CAPACITORS

SB

Low leakage current
Series

■ Dimensions, Rated Ripple Current

Capacitance (μF)	Rated (Surge) Voltage					
	63V (79)		80V (100)		100V (125)	
	SIZE	Ripple	SIZE	Ripple	SIZE	Ripple
1					5x11	10
2.2					5x11	20
3.3					5x11	30
4.7	5x11	35			5x11	40
10	5x11	50	6.3x11	60	6.3x11	65
22	6.3x11	80	8x11	110	8x11	115
33	6.3x11	100	8x11	130	10x12.5	160
47	8x11	140	10x12.5	180	10x17	230
100	10x12.5	230	10x17	310	13x20	410
220	10x20	430	13x20	560	16x26	750
330	13x20	610	13x25	750	16x26	920
470	13x25	800	16x26	1020	16x32	1200
1000	16x32	1460	18x36	1830		
2200						
3300						
4700						
6800						
10000						
15000						

☆ Size: D \times L (mm) ☆ Ripple Current: (mA/rms). 105°C, 120Hz

ALUMINUM ELECTROLYTIC CAPACITORS

SC

Low Impedance and high frequency Series

- Features: 105°C 1000~3000 hours, Low impedance, high permissible ripple current at high frequency and high operation temperature (-40 ~ +105°C)
- Recommended Applications: Applicable for switching regulator of computer, especially for high frequency
- Corresponding product to RoHS

SY
↑ Long Life
SC



Specifications

Item	Characteristics																																				
Operating Temperature Range	-40 ~ +105°C																																				
Rated Voltage Range	6.3 ~ 100VDC																																				
Rated Capacitance Range	4.7 ~ 15000 μF																																				
Capacitance Tolerance	± 20 % at 120Hz, 20°C																																				
Leakage Current (MAX)(20°C)	I=0.01CV or 3μA, whichever is greater. (After rated voltage applied for 2 minutes)																																				
Dissipation Factor (MAX) (tanδ) (120Hz, 20°C)	<table border="1"> <tr> <td>WV</td> <td>6.3</td> <td>10</td> <td>16</td> <td>25</td> <td>35</td> <td>50</td> <td>63</td> <td>100</td> </tr> <tr> <td>tanδ</td> <td>0.22</td> <td>0.19</td> <td>0.16</td> <td>0.14</td> <td>0.12</td> <td>0.10</td> <td>0.09</td> <td>0.08</td> </tr> </table>	WV	6.3	10	16	25	35	50	63	100	tanδ	0.22	0.19	0.16	0.14	0.12	0.10	0.09	0.08																		
	WV	6.3	10	16	25	35	50	63	100																												
tanδ	0.22	0.19	0.16	0.14	0.12	0.10	0.09	0.08																													
When nominal capacitance is over 1000μF, tanδ shall be added 0.02 to the listed value with increase of every 1000μF.																																					
Low Temperature Stability Impedance Ratio (MAX)	<table border="1"> <tr> <td>WV</td> <td>6.3</td> <td>10</td> <td>16</td> <td>25</td> <td>35</td> <td>50</td> <td>63</td> <td>100</td> </tr> <tr> <td>Z(120Hz)</td> <td></td> <td></td> <td></td> <td></td> <td></td> <td></td> <td></td> <td></td> </tr> <tr> <td>Z-25°C / Z+20°C</td> <td>4</td> <td>3</td> <td>3</td> <td>3</td> <td>3</td> <td>2</td> <td>2</td> <td>2</td> </tr> <tr> <td>Z-40°C / Z+20°C</td> <td>8</td> <td>6</td> <td>4</td> <td>4</td> <td>4</td> <td>4</td> <td>4</td> <td>4</td> </tr> </table>	WV	6.3	10	16	25	35	50	63	100	Z(120Hz)									Z-25°C / Z+20°C	4	3	3	3	3	2	2	2	Z-40°C / Z+20°C	8	6	4	4	4	4	4	4
	WV	6.3	10	16	25	35	50	63	100																												
	Z(120Hz)																																				
Z-25°C / Z+20°C	4	3	3	3	3	2	2	2																													
Z-40°C / Z+20°C	8	6	4	4	4	4	4	4																													
After applying rated voltage with ripple current for 3000 hours at 105°C, the capacitors shall meet the following requirements.																																					
Endurance	If dimension is down size, Endurance will be less 1000 hours than standard																																				
	<table border="1"> <tr> <td>Capacitance Change</td> <td>Within ± 20 % of initial value</td> </tr> <tr> <td>Dissipation Factor</td> <td>Not more than 200% of specified value</td> </tr> <tr> <td>Leakage Current</td> <td>Not more than the specified value</td> </tr> </table>	Capacitance Change	Within ± 20 % of initial value	Dissipation Factor	Not more than 200% of specified value	Leakage Current	Not more than the specified value																														
	Capacitance Change	Within ± 20 % of initial value																																			
	Dissipation Factor	Not more than 200% of specified value																																			
	Leakage Current	Not more than the specified value																																			
<table border="1"> <tr> <td>Case Dia</td> <td>5 x 11 ~ 10 x 12.5</td> <td>10 x 15 higher</td> </tr> <tr> <td>Life</td> <td>2000</td> <td>3000</td> </tr> </table>	Case Dia	5 x 11 ~ 10 x 12.5	10 x 15 higher	Life	2000	3000																															
Case Dia	5 x 11 ~ 10 x 12.5	10 x 15 higher																																			
Life	2000	3000																																			
* If dimension is down size, Endurance will be less 1000hrs than standard.																																					
Shelf Life	After placed at 105°C without voltage applied for 1000 hours, the capacitors shall meet the same requirement as Endurance.																																				

Diagram of Dimensions

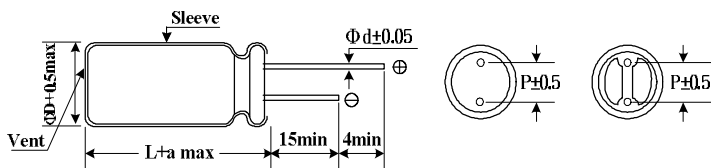

	5	6.3	8	10	13	16	18	22
ψD								
P	2.0	2.5	3.5	5.0	5.0	7.5	7.5	10.0
ψd	0.50	0.5	0.6	0.6	0.6	0.8	0.8	0.8
a	1.5	1.5	1.5	1.5	2.0	2.0	2.0	2.0

Multiplier for Ripple Current

Frequency coefficient

Frequency (Hz)	50	120	300	1K	10K	100K
Below 4.7 μF	0.30	0.40	0.50	0.70	0.80	1.00
5.6 ~ 33 μF	0.40	0.50	0.60	0.80	0.90	1.00
34 ~ 330 μF	0.60	0.70	0.80	0.90	0.95	1.00
331 ~ 1000 μF	0.65	0.90	0.90	0.98	1.00	1.00
1200 μF Above	0.85	0.90	0.95	0.98	1.00	1.00

ALUMINUM ELECTROLYTIC CAPACITORS



Low Impedance and high frequency Series

■ Dimensions, Rated Ripple Current, Max Impedance

Capacitance (μF)	Rated (Surge) Voltage											
	6.3V (8)			10V (13)			16V (20)			25V (32)		
	SIZE	Ripple	Z	SIZE	Ripple	Z	SIZE	Ripple	Z	SIZE	Ripple	Z
4.7												
6.8												
10										5x11	50	0.550
22												
33												
47										5x11	150	0.450
56							5x11	100	0.630	5x11	150	0.420
68							5x11	150	0.420	6.3x11	200	0.370
100				5x11	150	0.420	5x11	200	0.370	6.3x11	250	0.220
120				5x11	200	0.370	6.3x11	250	0.320	8x11	300	0.200
150	5x11	200	0.420	6.3x11	250	0.320	6.3x11	300	0.220	8x11	550	0.140
220	6.3x11	250	0.320	6.3x11	300	0.220	8x11	550	0.140	8x11	550	0.120
										8x15	750	0.100
270	6.3x11	250	0.220									
330	6.3x11	250	0.230	8x11	550	0.140	8x11	550	0.120	*8x15	660	0.100
	8x11	400	0.180				8x15	750	0.100	8x20	800	0.069
							10x12.5	688	0.080	10x16	900	0.086
470	*6.3x11	440	0.180	8x11	550	0.120	8x15	730	0.093	8x20	800	0.067
	8x11	550	0.140	8x15	750	0.100	10x12.5	800	0.085	10x12.5	760	0.086
										10x16	1050	0.064
680	*8x11	580	0.120	*8x11	640	0.110	10x16	1050	0.064	10x20	1100	0.039
	8x15	700	0.100	10x12.5	800	0.085						
820	8x20	750	0.085	10x16	1050	0.064	10x20	1100	0.044	10x20	1250	0.039
1000	*8x11	580	0.150	8x20	1080	0.065	*10x16	1140	0.043	*10x20	1160	0.047
	8x15	700	0.085	*10x12.5	930	0.075	10x20	1250	0.039	*10x25	1310	0.042
	8x20	800	0.069	10x16	990	0.085				13x20	1450	0.038
	10x12.5	690	0.080	10x20	1100	0.050						
1200	10x16	1000	0.064	10x20	1250	0.044	*10x25	1310	0.042	13x25	1600	0.035
							13x20	1450	0.038			
1500	*8x15	980	0.085	10x20	1450	0.039	*10x20	1200	0.045	*13x30	1750	0.032
	8x20	800	0.051				13x20	1600	0.034	16x25	2000	0.028
	*10x16	1070	0.055									
	10x20	1250	0.044									
2200	*10x20	1220	0.051	*10x20	1330	0.047	*10x30	1780	0.032	*13x30	1810	0.029
	*10x25	1310	0.048	*10x25	1450	0.039	*13x20	1720	0.033	*16x25	1660	0.032
	13x20	1450	0.043	13x20	1600	0.038	13x25	2000	0.028	16x32	2200	0.024
3300	*10x25	1400	0.043	*10x30	1740	0.032	*13x40	2200	0.026	*16x36	2540	0.019
	13x25	1700	0.035	13x25	2000	0.028	16x25	2200	0.024	18x36	2550	0.019
3900	13x25	1750	0.032									
4700	*13x30	1570	0.033	*13x25	1860	0.028	16x36	2550	0.019	18x36	2800	0.019
	*13x25	1520	0.032	16x25	2200	0.024						
	16x25	1800	0.028									
6800	16x32	2000	0.024	16x36	2550	0.019	18x36	2800	0.019	18x36	2800	0.019
8200	16x32	2350	0.019	18x36	2800	0.019						
10000	16x36	2550	0.019									
15000	18x36	3000	0.019									

☆ Size: Dφ x L (mm) ☆ Ripple Current: (mA/rms), 105°C, 100KHz ☆ Impedance (Ω), 20°C, 100KHz
 " * " is down size , Ripple Life is less 1000 hrs than standard

ALUMINUM ELECTROLYTIC CAPACITORS

SC

Low Impedance and high frequency Series

■ Dimensions, Rated Ripple Current, Max Impedance

Capacitance (μF)	RATED (SURAGE) VOLTAGE											
	35V (44)			50V (63)			63V (79)			100V (125)		
	SIZE	Ripple	Z	SIZE	Ripple	Z	SIZE	Ripple	Z	SIZE	Ripple	Z
4.7	5x11	115	1.200	5x11	115	2.000	5x11	115	2.200	5x11	120	2.000
6.8	5x11	120	1.000	5x11	120	1.850	5x11	120	2.000	5x11	140	1.850
10	5x11	140	0.900	5x11	140	1.700	5x11	140	1.850	6.3x11	200	1.500
15	5x11	170	0.690	5x11	180	1.200	5x11	200	1.700	6.3x11	250	1.200
22	5x11	190	0.600	5x11	200	0.700	6.3x11	250	1.200	8x11	300	0.790
33	5x11	200	0.580	6.3x11	250	0.600	6.3x11	300	0.900	8x15	450	0.590
47	6.3x11	250	0.390	6.3x11	300	0.520	8x11	450	0.700	10x16	550	0.350
68	6.3x11	300	0.220	8x11	450	0.350	8x11	550	0.520	10x20	650	0.240
100	6.3x11	300	0.180	8x11	450	0.290	8x20	650	0.350	13x20	800	0.180
	8x11	450	0.140	8x15	550	0.250						
120	8x11	550	0.130	8x20	650	0.210	10x16	800	0.300	13x25	1050	0.150
150	8x15	650	0.100	10x12.5	800	0.160	10x16	1050	0.200	13x25	1300	0.110
220	8x15	650	0.100	*10x16	1050	0.100	10x20	1300	0.150	16x25	1400	0.071
	10x12.5	800	0.069	10x25	1050	0.068						
330	*10x16	900	0.052	10x20	1300	0.072	13x20	1400	0.100	16x32	1550	0.049
	10x20	1050	0.044									
470	10x20	1300	0.039	*10x20	1390	0.075	13x25	1550	0.064	18x36	1770	0.038
				13x20	1400	0.060						
680	13x20	1400	0.038	13x25	1550	0.050	16x25	1700	0.052			
820	13x20	1550	0.034	16x25	1700	0.040	16x32	1900	0.048			
1000	13x25	1700	0.029	16x25	1900	0.039	16x32	2100	0.042			
1200	16x25	1900	0.028	16x32	2100	0.025	16x36	2550	0.036			
1500	16x25	2100	0.024	16x36	2550	0.025	18x36	2800	0.033			
2200	*16x32	2300	0.021	18x40	2800	0.025						
	16x36	2550	0.019									
3300	18x36	2880	0.019									
3900												
4700												
6800												
8200												
10000												
15000												

☆ Size: D×L (mm) ☆ Ripple Current: (mA/rms), 105°C, 100KHz ☆ Impedance (Ω), 20°C, 100KHz

" * " is down size , Ripple Life is less 1000 hrs than standard

ALUMINUM ELECTROLYTIC CAPACITORS

SJ

Low Impedance and High ripple
Series

- Features: 105°C, 1000~5000hrs Low Impedance and High ripple
- Recommended Applications : AV(TV, Video, Audio), Monitor/Computer, OA/HA/Communication, Converter/Inverter, Adapter, SMPS
- Corresponding product to RoHS

SJ
↑ High ripple
SC



Specifications

Item	Characteristics									
Operating Temperature Range	-40 ~ +105°C									
Rated Voltage Range (WV)	6.3 ~ 100VDC									
Rated Capacitance Range	5.6 ~ 6800 µF									
Capacitance Tolerance (20°C)	± 20 % at 120Hz									
Leakage Current (MAX) (20°C)	I ≤ 0.01CV or 3µA ,whichever is greater. (After rated voltage applied for 2 minutes)									
	I= Leakage Current (µA) C= Nominal Capacitance (µF) V= Rated Voltage (V)									
Dissipation Factor (MAX) (tanδ) (120Hz ,20°C)	WV	6.3	10	16	25	35	50	63	100	
	tanδ	0.22	0.19	0.16	0.14	0.12	0.10	0.09	0.08	
When nominal capacitance is over 1000µF, tanδ shall be added 0.02 to the listed value with increase of every 1000µF.										
Low Temperature Stability Impedance Ratio (Max)	WV	6.3	10	16	25	35	50	63	100	
	Z(120Hz)									
	Z(-25°C) / Z(20°C)	2	2	2	2	2	2	2	2	2
	Z(-40°C) / Z(20°C)	3	3	3	3	3	3	3	3	3
Endurance	After applying rated voltage with max ripple current for 1000~5000 hours at 105°C, the capacitor shall meet the following requirement.									
	Capacitance Change	Within±25% of the initial value								
	Dissipation Factor	Not more than 200% of the specified value								
	Leakage Current	Not more than the specified value								
	Case (ψ)	Life time (hrs)								
	L=7	1000								
	ψD ≤ 11	ψD ≤ 6.3	2000							
		ψD = 8	3000							
		ψD = 10	4000							
		ψD ≥ 13	5000							
*If dimension is down size,Endurance will be less 1000 hours than standard.										
Shelf Life	After placed at 105°C without voltage applied for 1000 hours (500 hours for L=7), the capacitor shall meet the same requirement as Endurance.									

Dimensions [mm]

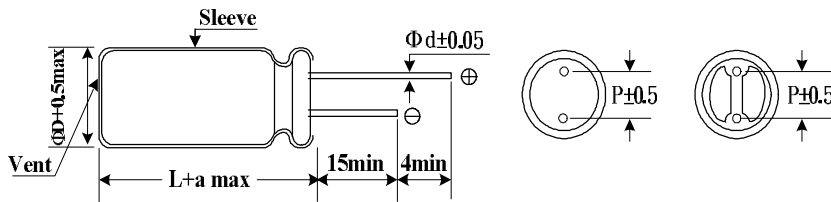

ψD	4	5	6.3	8	10	13	16	18
P	1.5	2	2.5	3.5	5.0	5.0	7.5	7.5
ψd	0.45	0.5 (0.45)	0.5 (0.45)	0.6 (0.5)	0.6	0.6	0.8	0.8
a	1.0	1.5 (1.0)	1.5 (1.0)	1.5 (1.0)	1.5	2.0	2.0	2.0

() : L = 7

Multiplier for Ripple Current

Frequency coefficient

Cap (µF) \ Freq. (Hz)	50	120	1K	10K	100K
5.6 ~ 390	0.60	0.70	0.85	0.95	1.00
470 ~ 1000	0.65	0.75	0.90	0.98	1.00
1200 ~ 6800	0.75	0.80	0.95	1.00	1.00

ALUMINUM ELECTROLYTIC CAPACITORS

SJ

Low Impedance and High ripple
Series

■ Dimensions, Rated Ripple Current, Max Impedance

Capacitance (μ F)	Rated (Surge) Voltage														
	6.3V (8)			10V (13)			16V (20)			25V (32)			35V (44)		
	SIZE	Ripple	Z	SIZE	Ripple	Z	SIZE	Ripple	Z	SIZE	Ripple	Z	SIZE	Ripple	Z
10													4x7	130	0.96
15										4x7	130	0.94	5x7	190	0.57
18							4x7	130	0.92	5x7	170	0.69	5x7	210	0.47
27				4x7	130	0.89	5x7	190	0.61	5x7	210	0.46	5x11	230	0.37
33				5x7	160	0.75	5x7	210	0.45	5x11	220	0.42	5x11	250	0.30
39	4x7	130	0.85	5x7	175	0.64	5x11	220	0.43	5x11	230	0.36	6.3x7	300	0.25
47	5x7	175	0.7	5x7	190	0.53	5x11	230	0.36	5x11	250	0.3	6.3x11	380	0.15
													8x7	350	0.19
56	5x7	190	0.56	5x7	210	0.44	5x11	250	0.3	6.3x7	300	0.24	6.3x11	410	0.13
													8x7	380	0.16
68	5x7	210	0.43	5x11	210	0.44	6.3x7	300	0.24	6.3x11	340	0.19	8x11	510	0.12
										8x7	310	0.22			
100	5x11	200	0.43	5x11	250	0.3	6.3x11	370	0.16	6.3x11	410	0.13	8x11	620	0.105
	6.3x7	240	0.35				8x7	350	0.18	8x7	380	0.15			
120	5x11	220	0.38	6.3x7	300	0.23	6.3x11	410	0.13	8x11	560	0.12	8x11	680	0.088
	6.3x7	270	0.29				8x7	380	0.15						
150	5x11	250	0.3	8x7	350	0.18	8x11	510	0.12	8x11	630	0.105	8x11	760	0.072
	6.3x7	300	0.23												
180	8x7	340	0.18	8x7	380	0.15	8x11	560	0.11	8x11	690	0.088	8x15	910	0.068
													10x12.5	930	0.065
220	8x7	380	0.15	6.3x11	410	0.13	8x11	620	0.1	8x11	760	0.072	10x12.5	1030	0.053
270	6.3x11	370	0.16	8x11	580	0.12	8x11	690	0.088	8x15	900	0.068	8x20	1250	0.041
										10x12.5	930	0.065			
330	6.3x11	410	0.13	8x11	640	0.1	8x11	760	0.072	10x12.5	1030	0.053	10x16	1430	0.038
470	8x11	680	0.086	8x11	760	0.072	8x15	1000	0.056	8x20	1250	0.041	10x20	1820	0.026
							10x12.5	1030	0.053	10x16	1430	0.038			
560	8x11	760	0.072	8x15	910	0.068	8x20	1140	0.049	10x20	1650	0.032	10x25	2150	0.023
				10x12.5	940	0.064	10x16	1300	0.046						
680	8x15	900	0.062	10x12.5	1030	0.053	8x20	1250	0.041	10x20	1820	0.026	13x20	2360	0.023
							10x16	1430	0.038						
820	8x15	1000	0.056	8x20	1130	0.05	10x20	1650	0.032	10x25	2150	0.023	13x25	2510	0.02
				10x16	1300	0.046									
1000	10x12.5	1030	0.053	8x20	1250	0.041	10x20	1820	0.026	13x20	2360	0.021	13x25	2770	0.018
				10x16	1430	0.038									
1200	8x20	1250	0.041	10x20	1820	0.026	10x25	2150	0.023	13x25	2510	0.02	13x30	3290	0.016
	10x16	1430	0.038										16x20	3140	0.018
1500	10x20	1820	0.026	10x25	2150	0.023	13x20	2360	0.021	13x25	2770	0.018	13x35	3400	0.015
1800	10x25	1940	0.025	13x20	2230	0.022	13x25	2510	0.02	13x30	3290	0.016	16x25	3460	0.016
										16x20	3140	0.018			
2200	10x25	2150	0.023	13x20	2360	0.021	13x25	2770	0.018	13x35	3400	0.015			
2700	13x20	2230	0.022	13x25	2510	0.02	13x30	3290	0.016	16x25	3460	0.016			
							16x20	3140	0.018						
3300	13x20	2360	0.021	13x25	2770	0.018	13x35	3400	0.015						
3900	13x25	2770	0.018	13x30	3290	0.016	16x25	3460	0.016						
				16x20	3140	0.018									
4700	13x30	3290	0.016	13x35	3400	0.015									
5600	13x35	3400	0.015	16x25	3460	0.016									
	16x20	3140	0.018												
6800	16x25	3460	0.016												

☆ Size : D ϕ x L (mm) ☆ Ripple Current : mA/rms, 105 $^{\circ}$ C, 100KHz ☆ Impedance : Z(Ω), 20 $^{\circ}$ C, 100KHz

ALUMINUM ELECTROLYTIC CAPACITORS

SJ

**Low Impedance and High ripple
Series**

■ Dimensions, Rated Ripple Current, Max Impedance

Capacitance (μ F)	Rated (Surge) Voltage								
	50V (63)			63V (79)			100V (125)		
	SIZE	Ripple	Z	SIZE	Ripple	Z	SIZE	Ripple	Z
5.6	4x7	130	1						
6.8	5x7	170	0.74				5x11	125	1.4
10	5x7	210	0.5				6.3x11	170	0.95
15	6.3x7	220	0.38	5x11	136	1.19	6.3x 11	210	0.57
	5x11	215	0.48						
22	6.3x7	300	0.26	6.3x11	176	0.88	8x11	330	0.44
	5x11	240	0.34						
27	8x7	340	0.21	6.3x11	192	0.58	8x11	360	0.36
33	8x7	380	0.17	6.3x11	216	0.47	8x15	375	0.3
39	6.3x11	330	0.16	8x11	308	0.42	8x15	450	0.25
47	6.3x11	360	0.15	8x11	336	0.35	10x12.5	450	0.24
56	6.3x11	390	0.14	8x11	400	0.35	8x20	570	0.19
68	8x11	600	0.11	8x15	488	0.26	10x16	580	0.18
				10x12.5	500	0.24			
82	8x11	660	0.09	8x15	536	0.22	10x20	750	0.13
				10x12.5	552	0.20	13x16	740	0.13
100	8x11	730	0.074	10x16	640	0.16	10x25	880	0.12
120	8x15	950	0.065	8x20	656	0.16	13x20	1050	0.094
				10x16	760	0.15			
150	10x12.5	980	0.061	10x20	808	0.13	13x25	1100	0.085
				13x16	832	0.13			
180	8x20	1190	0.046	10x20	880	0.11	13x25	1200	0.071
				13x16	912	0.11			
220	10x16	1370	0.042	10x25	1040	0.099	13x30	1410	0.063
							16x20	1300	0.071
270	10x20	1580	0.03	13x20	1200	0.081	13x35	1560	0.052
							16x25	1600	0.053
							18x20	1470	0.069
330	10x25	1870	0.028	13x25	1480	0.058	13x40	1700	0.046
390	13x20	1870	0.028	13x30	1640	0.063	16x32	1750	0.041
				16x20	1448	0.073	18x25	1620	0.049
470	13x20	2050	0.027	13x30	1800	0.061	16x36	1890	0.033
				16x20	1592	0.061	18x32	1780	0.039
560	13x25	2410	0.023	13x35	1960	0.047	16x40	2080	0.03
				16x25	2040	0.043	18x36	2060	0.031
680	13x30	2860	0.021	13x40	2224	0.039	18x40	2570	0.028
				18x20	1960	0.051			
820	13x35	2960	0.019	16x32	2248	0.035			
	16x20	2730	0.023	18x25	2224	0.042			
1000	16x32	3350	0.021	16x36	2272	0.028			
				18x32	2616	0.034			
1200				16x40	2672	0.026			
				18x36	2648	0.027			
1500				18x40	2736	0.024			

☆ Size: D \times L (mm) ☆ Ripple Current : mA/rms,105°C,100KHz ☆ Impedance : Z(Ω),20°C,100KHz

ALUMINUM ELECTROLYTIC CAPACITORS

TB Low Impedance and Long Life Series



TB
↑
SJ Long Life

- Features : 105°C 5000~6000hrs Low Impedance and long Life
- Recommended Applications : AV(TV, Video, Audio), Monitor/Computer, OA/HA/Communication, Converter/Inverter, Adapter, SMPS
- Corresponding product to RoHS

Specifications

Item	Characteristics																								
Operating Temperature Range	-40 ~ +105°C																								
Rated Voltage Range	6.3~35VDC																								
Rated Capacitance Range	27~ 8200μF																								
Capacitance Tolerance	± 20 % at 120Hz , 20°C																								
Leakage Current (MAX) (20°C)	I=0.01CV or 3(μA) , whichever is greater. (After rated voltage applied for 2 minutes) I= Leakage Current (μA) C= Nominal Capacitance (μF) V= Rated Voltage (V) (20°C)																								
Dissipation Factor (MAX) (tanδ) (120Hz ,20°C)	<table border="1" style="margin: auto;"> <tr> <td style="text-align: center;">WV</td> <td style="text-align: center;">6.3</td> <td style="text-align: center;">10</td> <td style="text-align: center;">16</td> <td style="text-align: center;">25</td> <td style="text-align: center;">35</td> </tr> <tr> <td style="text-align: center;">tanδ</td> <td style="text-align: center;">0.22</td> <td style="text-align: center;">0.19</td> <td style="text-align: center;">0.16</td> <td style="text-align: center;">0.14</td> <td style="text-align: center;">0.12</td> </tr> </table>	WV	6.3	10	16	25	35	tanδ	0.22	0.19	0.16	0.14	0.12												
	WV	6.3	10	16	25	35																			
tanδ	0.22	0.19	0.16	0.14	0.12																				
When nominal capacitance is over 1000uF, Tanδ shall be added 0.02 to the listed value with increase of every 1000uF.																									
Low Temperature Stability Impedance Ratio (MAX)	<table border="1" style="margin: auto;"> <tr> <td style="text-align: center;">WV</td> <td style="text-align: center;">6.3</td> <td style="text-align: center;">10</td> <td style="text-align: center;">16</td> <td style="text-align: center;">25</td> <td style="text-align: center;">35</td> </tr> <tr> <td style="text-align: center;">Z(120Hz)</td> <td style="text-align: center;">2</td> <td style="text-align: center;">2</td> <td style="text-align: center;">2</td> <td style="text-align: center;">2</td> <td style="text-align: center;">2</td> </tr> <tr> <td style="text-align: center;">Z-25°C / Z+20°C</td> <td style="text-align: center;">2</td> <td style="text-align: center;">2</td> <td style="text-align: center;">2</td> <td style="text-align: center;">2</td> <td style="text-align: center;">2</td> </tr> <tr> <td style="text-align: center;">Z-40°C / Z+20°C</td> <td style="text-align: center;">3</td> <td style="text-align: center;">3</td> <td style="text-align: center;">3</td> <td style="text-align: center;">3</td> <td style="text-align: center;">3</td> </tr> </table>	WV	6.3	10	16	25	35	Z(120Hz)	2	2	2	2	2	Z-25°C / Z+20°C	2	2	2	2	2	Z-40°C / Z+20°C	3	3	3	3	3
	WV	6.3	10	16	25	35																			
	Z(120Hz)	2	2	2	2	2																			
Z-25°C / Z+20°C	2	2	2	2	2																				
Z-40°C / Z+20°C	3	3	3	3	3																				
Endurance	After applying rated voltage with rated ripple current for 5000~6000hours at 105°C , the capacitors shall meet the following requirements.																								
	<table border="1" style="margin: auto;"> <tr> <td style="text-align: center;">Capacitance Change</td> <td style="text-align: center;">Within ± 25 % of initial value(6.3, 10Vdc :±30%)</td> </tr> <tr> <td style="text-align: center;">Dissipation Factor</td> <td style="text-align: center;">200% or less of initial specified value</td> </tr> <tr> <td style="text-align: center;">Leakage Current</td> <td style="text-align: center;">initial specified value or less</td> </tr> </table>	Capacitance Change	Within ± 25 % of initial value(6.3, 10Vdc :±30%)	Dissipation Factor	200% or less of initial specified value	Leakage Current	initial specified value or less																		
	Capacitance Change	Within ± 25 % of initial value(6.3, 10Vdc :±30%)																							
	Dissipation Factor	200% or less of initial specified value																							
Leakage Current	initial specified value or less																								
<table border="1" style="margin: auto;"> <tr> <td style="text-align: center;">Dφ</td> <td style="text-align: center;">φ5~6.3φ</td> <td style="text-align: center;">φ8~16φ</td> </tr> <tr> <td style="text-align: center;">Life</td> <td style="text-align: center;">5000hrs</td> <td style="text-align: center;">6000hrs</td> </tr> </table>	Dφ	φ5~6.3φ	φ8~16φ	Life	5000hrs	6000hrs																			
Dφ	φ5~6.3φ	φ8~16φ																							
Life	5000hrs	6000hrs																							
Shelf Life	After placed at 105°C without voltage applied for 500 hours, the capacitors shall meet the same requirement as Endurance.																								

Diagram of Dimensions

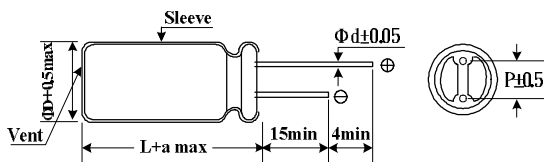

ψD	5	6.3	8	10	13	16
P	2.0	2.5	3.5	5.0	5.0	7.5
ψd	0.5	0.5	0.6	0.6	0.6	0.8
a	1.5	1.5	1.5	1.5	2.0	2.0

Multiplier for Ripple Current

Frequency coefficient

Freq. (Hz)	120	1K	10K	100K
Cap(μF)				
27 to 150	0.40	0.75	0.90	1.00
220 to 560	0.50	0.85	0.94	1.00
680 to 1800	0.60	0.87	0.95	1.00
2200 to 3900	0.75	0.90	0.95	1.00
4700 to 8200	0.85	0.95	0.98	1.00

ALUMINUM ELECTROLYTIC CAPACITORS

TB Low Impedance & Long Life Series

■ Dimensions, Rated Ripple Current, Max Impedance

Capacitance (μF)	Rated (Surge) Voltage														
	6.3V (8)			10V (13)			16V (20)			25V (32)			35V (44)		
	SIZE	Ripple	Z	SIZE	Ripple	Z	SIZE	Ripple	Z	SIZE	Ripple	Z	SIZE	Ripple	Z
27															
47													5x11	330	0.24
56															
68										5x11	330	0.24			
100							5x11	330	0.24				6.3x11	500	0.11
120															
150				5x11	330	0.24				6.3x11	500	0.11			
220	5x11	330	0.24				6.3x11	500	0.11				8x12	900	0.062
270													8x15	1210	0.048
330				6.3x11	500	0.11				8x12	900	0.062	10x12.5	1240	0.053
390										8x15	1210	0.048	8x20	1410	0.041
470	6.3x11	500	0.11				8x12	900	0.062	10x12.5	1240	0.053	10x16	1650	0.038
560										8x20	1410	0.041	10x20	1960	0.026
680				8x12	900	0.062	8x15	1210	0.048	10x16	1650	0.038	10x25	2250	0.023
							10x12.5	1240	0.053						
820	8x12	900	0.062							10x20	1960	0.026			
1000				8x15	1210	0.048	8x20	1410	0.041	10x25	2250	0.023	13x20	2480	0.023
				10x12.5	1240	0.053	10x16	1650	0.038						
1200	8x15	1210	0.048										13x25	2900	0.020
	10x12.5	1240	0.053												
1500	8x20	1410	0.041	8x20	1410	0.041	10x20	1960	0.026	13x20	2480	0.023	13x30	3450	0.017
				10x16	1650	0.038							16x20	3250	0.018
1800	10x16	1650	0.038	10x20	1960	0.026	10x25	2250	0.023	13x25	2900	0.020	13x35	3570	0.016
2200	10x20	1960	0.026	10x25	2250	0.023	13x20	2480	0.023	13x30	3450	0.017	16x25	3630	0.017
										16x20	3250	0.018			
2700	10x25	2250	0.023				13x25	2900	0.020	13x35	3570	0.016			
3300				13x20	2480	0.023	13x30	3450	0.017	16x25	3630	0.017			
							16x20	3250	0.018						
3900	13x20	2480	0.023	13x25	2900	0.020	13x35	3570	0.016						
4700	13x25	2900	0.020	13x30	3450	0.017	16x25	3630	0.017						
				16x20	3250	0.018									
5600	13x30	3450	0.017	13x35	3570	0.016									
6800	13x35	3570	0.016	16x25	3630	0.017									
	16x20	3250	0.018												
8200	16x25	3630	0.017												

☆ Size: D \times L (mm) ☆ Ripple Current: (mA/rms), 105°C, 100KHz ☆ Impedance (Ω), 20°C, 100KHz

ALUMINUM ELECTROLYTIC CAPACITORS

SY

Low Impedance & Long Life Series

■ Features : Low Impedance , high permissible ripple current at high frequency and long life than SC

■ Recommended Applications:

Used switching regulator applications in computers. Especially for high frequency.

■ Corresponding product to RoHS

SY

↑ Long Life
SC



■ Specifications

Item	Characteristics																																				
Operating Temperature Range	-40 ~ +105°C																																				
Rated Voltage Range	6.3 ~ 100VDC																																				
Rated Capacitance Range	2.2 ~ 15000 µF																																				
Capacitance Tolerance	±20% at 120Hz , 20°C																																				
Leakage Current (MAX) (20°C)	I=0.01CV or 3µA , whichever is greater. (After rated voltage applied for 2 minutes) I= Leakage Current (µA) C= Nominal Capacitance (µF) V= Rated Voltage (V)																																				
Dissipation Factor (MAX) (tanδ) (120Hz ,20°C)	<table border="1" style="width: 100%; text-align: center;"> <tr> <td>WV</td> <td>6.3</td> <td>10</td> <td>16</td> <td>25</td> <td>35</td> <td>50</td> <td>63</td> <td>100</td> </tr> <tr> <td>tanδ</td> <td>0.22</td> <td>0.19</td> <td>0.16</td> <td>0.14</td> <td>0.12</td> <td>0.10</td> <td>0.09</td> <td>0.08</td> </tr> </table>	WV	6.3	10	16	25	35	50	63	100	tanδ	0.22	0.19	0.16	0.14	0.12	0.10	0.09	0.08																		
	WV	6.3	10	16	25	35	50	63	100																												
tanδ	0.22	0.19	0.16	0.14	0.12	0.10	0.09	0.08																													
When nominal capacitance is over 1000µF, tanδ shall be added 0.02 to the listed value with increase of every 1000µF.																																					
Low Temperature Stability Impedance Ratio (MAX)	<table border="1" style="width: 100%; text-align: center;"> <tr> <td>WV</td> <td>6.3</td> <td>10</td> <td>16</td> <td>25</td> <td>35</td> <td>50</td> <td>63</td> <td>100</td> </tr> <tr> <td>Z(120Hz)</td> <td></td> <td></td> <td></td> <td></td> <td></td> <td></td> <td></td> <td></td> </tr> <tr> <td>Z-25°C / Z+20°C</td> <td>4</td> <td>3</td> <td>2</td> <td>2</td> <td>2</td> <td>2</td> <td>2</td> <td>2</td> </tr> <tr> <td>Z-40°C / Z+20°C</td> <td>8</td> <td>6</td> <td>4</td> <td>3</td> <td>3</td> <td>3</td> <td>3</td> <td>3</td> </tr> </table>	WV	6.3	10	16	25	35	50	63	100	Z(120Hz)									Z-25°C / Z+20°C	4	3	2	2	2	2	2	2	Z-40°C / Z+20°C	8	6	4	3	3	3	3	3
	WV	6.3	10	16	25	35	50	63	100																												
	Z(120Hz)																																				
Z-25°C / Z+20°C	4	3	2	2	2	2	2	2																													
Z-40°C / Z+20°C	8	6	4	3	3	3	3	3																													
After applying rated voltage with rated ripple current for 6000 hours at 105°C , the capacitors shall meet the following requirements.																																					
Endurance	<table border="1" style="width: 100%; text-align: center;"> <tr> <td>Capacitance Change</td> <td colspan="4">Within ± 25% of initial value</td> </tr> <tr> <td>Dissipation Factor</td> <td colspan="4">Not more than 200% of specified value</td> </tr> <tr> <td>Leakage Current</td> <td colspan="4">Not more than the specified value</td> </tr> <tr> <td>Dψ</td> <td>5ψ~6.3ψ</td> <td>8ψ~10ψx12.5</td> <td>10ψx15~12ψ</td> <td>13ψ~18ψ</td> </tr> <tr> <td>Life</td> <td>3000 hrs</td> <td>4000 hrs</td> <td>5000 hrs</td> <td>6000 hrs</td> </tr> </table>	Capacitance Change	Within ± 25% of initial value				Dissipation Factor	Not more than 200% of specified value				Leakage Current	Not more than the specified value				Dψ	5ψ~6.3ψ	8ψ~10ψx12.5	10ψx15~12ψ	13ψ~18ψ	Life	3000 hrs	4000 hrs	5000 hrs	6000 hrs											
	Capacitance Change	Within ± 25% of initial value																																			
	Dissipation Factor	Not more than 200% of specified value																																			
	Leakage Current	Not more than the specified value																																			
	Dψ	5ψ~6.3ψ	8ψ~10ψx12.5	10ψx15~12ψ	13ψ~18ψ																																
Life	3000 hrs	4000 hrs	5000 hrs	6000 hrs																																	
*If dimension is down size, Endurance will be less 1000 hours than standard.																																					
Shelf Life	After placed at 105°C without voltage applied for 1000 hours, the capacitors shall meet the same requirement as Endurance.																																				

■ Diagram of Dimensions

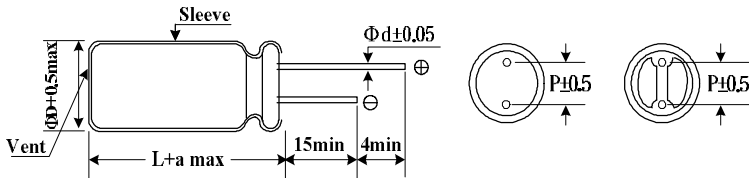

	5	6.3	8	10	13	16	18
ψD	5	6.3	8	10	13	16	18
P	2.0	2.5	3.5	5.0	5.0	7.5	7.5
ψd	0.5	0.5	0.6	0.6	0.6	0.8	0.8
a	1.5	1.5	1.5	1.5	2.0	2.0	2.0

■ Multiplier for Ripple Current

Frequency coefficient

Frequency (Hz)	120	1 K	10 K	100 K
22 ~ 180 µF	0.40	0.75	0.90	1.00
220 ~ 560 µF	0.50	0.85	0.94	1.00
680 ~ 1800 µF	0.60	0.87	0.95	1.00
2200 ~ 3900 µF	0.75	0.90	0.95	1.00
4700 µF Higher	0.85	0.95	0.98	1.00

ALUMINUM ELECTROLYTIC CAPACITORS

SY

Low Impedance & Long Life Series

■ Dimensions, Rated Ripple Current, Max Impedance

Capacitance (μF)	Rated (Surge) Voltage								
	6.3V (8)			10V (13)			16V (20)		
	SIZE	Ripple	Z	SIZE	Ripple	Z	SIZE	Ripple	Z
56							5x11	210	0.580
100				5x11	210	0.580	6.3x11	250	0.230
120							6.3x11	340	0.220
150	5x11	210	0.580						
220							6.3x11	469	0.185
				6.3x11	340	0.220	8x11	582	0.150
330	6.3x11	340	0.220				8x11	640	0.130
470	6.3x11	510	0.160	8x11	640	0.130	*8x15	840	0.087
							8x20	950	0.078
							*10x12.5	865	0.080
							10X16	1210	0.060
680	8x11	640	0.130	8x15	840	0.087	8x20	1050	0.069
							10X16	1210	0.060
820	10x12.5	865	0.080	10x12.5	865	0.080			
1000	8x15	840	0.087	8x20	1050	0.069	8x20	1050	0.069
				10X16	1210	0.060	*10X16	1210	0.060
							10x20	1400	0.046
							13x16	1450	0.049
1200	8x20	1050	0.069	10x20	1400	0.046	10x25	1650	0.042
	10X16	1210	0.060						
1500	8x20	1050	0.069	10x25	1650	0.042	10x30	1910	0.031
	*10X16	1210	0.060	13x16	1450	0.049	13x20	1900	0.035
	10x20	1400	0.046				16x16	1940	0.042
1800	13x16	1450	0.049						
2200	*10x20	1400	0.046	10x30	1910	0.031	13x25	2230	0.027
	10x25	1650	0.042	13x20	1900	0.042	18x16	2210	0.043
				16x16	1940	0.042			
2700	10x30	1910	0.031	18x16	2210	0.043	13x30	2650	0.024
	16x16	1940	0.042				16x20	2530	0.027
3300	10x25	1650	0.042	10x30	1910	0.031			
	13x20	1900	0.035	13x25	2230	0.027	13X35	2880	0.020
3900	13x25	2230	0.027	13x30	2650	0.024	13x40	3350	0.017
	18x16	2210	0.043	16x20	2530	0.027	16x25	2930	0.021
							18x20	2860	0.026
4700	13x30	2650	0.024	13X35	2880	0.020	16x32	3450	0.017
							18x25	3140	0.019
5600	13X35	2880	0.020	13x40	3350	0.017	16X36	3610	0.015
	16x20	2530	0.027	16x25	2930	0.021	18x32	4170	0.015
				18x20	2860	0.026			
6800	13x40	3350	0.017	16x32	3450	0.017	16x40	4080	0.013
	16x25	2930	0.021	18x25	3140	0.019			
	18x20	2860	0.026						
8200	16x32	3450	0.017	16X36	3610	0.015	18x36	4220	0.014
				18x32	4170	0.015			
10000	16X36	3610	0.015	16x40	4080	0.013	18x40	4280	0.012
	18x25	3140	0.017	18x36	4220	0.014			
12000	18x32	4170	0.015	18x40	4280	0.012			
15000	18x36	4220	0.014						

☆ Size: D \times L (mm) ☆ Ripple Current: (mA/rms), 105°C, 100KHz ☆ Impedance (Ω), 20°C, 100KHz
 " * " is down size, Ripple life is less 1000 hrs than standard.

ALUMINUM ELECTROLYTIC CAPACITORS

SY

Low Impedance & Long Life Series

■ Dimensions, Rated Ripple Current, Max Impedance

Capacitance (μF)	Rated (Surge) Voltage														
	25V (32)			35V (44)			50V (63)								
	SIZE	Ripple	Z	SIZE	Ripple	Z	SIZE	Ripple	Z						
2.2							5x11	85	2.280						
4.7				5x11	95	2.400	5x11	100	2.000						
10				5x11	130	1.600	5x11	135	1.200						
22							5x11	180	0.700						
33				5x11	210	0.580	6.3x11	245	0.490						
47	5x11	210	0.580	6.3x11	275	0.390	6.3x11	300	0.520						
56				6.3x11	340	0.220	6.3x11	295	0.300						
68				6.3x11	500	0.170									
82				6.3x11	540	0.160									
100	6.3x11	340	0.220	8x11	580	0.150	8x11	555	0.170						
120							8x15	730	0.120						
150	8x11	640	0.160	8x11	640	0.130	10x12.5	760	0.120						
180							8x20	910	0.091						
220	8x11	640	0.130	*8x15	840	0.087	10X16	1050	0.084						
				10x12.5	865	0.080									
270				8x20	1050	0.069	10x20	1220	0.060						
							13x16	1260	0.061						
330	8x15	840	0.087	*10X16	1210	0.060	*10x20	1400	0.058						
	10x12.5	865	0.080	10x20	1400	0.046	10x25	1440	0.055						
470	8x20	1050	0.069	10x20	1400	0.046	10x30	1690	0.043						
	*10x12.5	1050	0.070	13x16	1450	0.049	13x20	1660	0.045						
560							16x16	1690	0.055						
							10x25	1650	0.042	13x25	1950	0.034			
680							18x16	1930	0.054						
							10x20	1400	0.046	10x30	1910	0.031	13x30	2310	0.030
							13x16	1450	0.049	13x20	1900	0.035			
820							16x16	1940	0.042						
							10x25	1650	0.042	13x20	1900	0.035	13X35	2510	0.025
													16x20	2210	0.034
1000							13x25	2230	0.027	13x40	2920	0.021			
							10x30	1910	0.031	18x16	2210	0.043	16x25	2555	0.025
							13x20	1900	0.035				18x20	2490	0.036
							16x16	1940	0.042						
1200							18x16	2210	0.043	13x30	2650	0.024	16x32	3010	0.022
										16x20	2530	0.027	18x25	2740	0.026
1500							*13x20	1900	0.035	13X35	2880	0.020	16X36	3150	0.019
							13x25	2230	0.027						
1800							13x30	2650	0.024	13x40	3350	0.017	16x40	3710	0.016
							16x20	2530	0.027	16x25	2930	0.021	18x32	3635	0.021
										18x20	2860	0.026			
2200							13X35	2880	0.020	16x32	3450	0.017	18x36	3680	0.017
							18x20	2860	0.026	18x25	3140	0.019			
2700							13x40	3350	0.017	16X36	3610	0.015	18x40	3800	0.014
							16x25	2930	0.021	18x32	4170	0.015			
3300							16x32	3450	0.017	16x40	4080	0.013			
							18x25	3140	0.019	18x36	4220	0.014			
3900							18x32	4170	0.015	18x40	4280	0.012			
4700							18x36	4220	0.014						
5600							18x40	4280	0.012						

☆ Size: D \times L (mm) ☆ Ripple Current: (mA/rms), 105°C, 100KHz ☆ Impedance (Ω), 20°C, 100KHz
 " * " is down size, Ripple life is less 1000 hrs than standard.

ALUMINUM ELECTROLYTIC CAPACITORS

SY

Low Impedance & Long Life
Series

■ Dimensions, Rated Ripple Current, Max Impedance

Capacitance (μF)	Rated (Surge) Voltage								
	63V (79)			100V (125)					
	SIZE	Ripple	Z	SIZE	Ripple	Z			
6.8				5×11	55	2.3			
15	5×11	55	2.3	6.3×11	115	1.2			
27				8×12	232	0.63			
33	6.3×11	115	1.2						
39				8×15	300	0.45			
47				10×12.5	288	0.43			
56	8×12	232	0.63	8×20	362	0.33			
68				10×16	357	0.31			
82	8×15	300	0.45	10×20	466	0.21			
	10×12.5	288	0.43	13×16	466	0.23			
100				10×25	531	0.2			
120	8×20	362	0.33	10×30	663	0.15			
	10×16	357	0.31	13×20	690	0.16			
150				16×16	795	0.14			
180	10×20	466	0.21	13×25	784	0.12			
	13×16	466	0.23	18×16	920	0.12			
220	10×25	531	0.2	13×30	905	0.1			
				16×20	1040	0.091			
270	10×30	663	0.15						
	13×20	690	0.16	13X35	1050	0.083			
	16×16	795	0.14	16×25	1250	0.073			
330	13×25	784	0.12	13×40	1180	0.071			
				18×20	1240	0.08			
390				16×32	1570	0.054			
	18×16	920	0.12	18×25	1490	0.057			
470	13×30	905	0.1	16×36	1790	0.045			
	16×20	1040	0.091	18×32	1630	0.047			
560	13X35	1050	0.083						
	16×25	1250	0.073	16×40	2020	0.04			
680	13×40	1180	0.071						
	18×20	1240	0.08	18×36	1790	0.04			
820	16×32	1570	0.054						
	18×25	1490	0.057	18×40	2330	0.036			
1000	16×36	1790	0.045						
	18×32	1630	0.047						
1200	16×40	2020	0.04						

☆ Size: Dφx L (mm) ☆ Ripple Current: (mA/rms), 105°C, 100KHz ☆ Impedance (Ω), 20°C, 100KHz

ALUMINUM ELECTROLYTIC CAPACITORS

TA Series Low Impedance & Long Life

- Features : 105°C 4000~10000hrs Low Impedance and long Life
- Recommended Applications:
Applicable for SMPS, Adaptor, Charger, Monitor/Computer
- Corresponding product to RoHS

TA
↑
SY Long Life



Specifications

Item	Characteristics																								
Operating Temperature Range	-40 ~ +105°C																								
Rated Voltage Range	6.3~35VDC																								
Rated Capacitance Range	33 ~ 8200μF																								
Capacitance Tolerance	± 20 % at 120Hz , 20°C																								
Leakage Current (MAX) (20°C)	I=0.01CV or 3(μA) , whichever is greater. (After rated voltage applied for 2 minutes) I= Leakage Current (μA) C= Nominal Capacitance (μF) V= Rated Voltage (V) (20°C)																								
Dissipation Factor (MAX) (tanδ) (120Hz ,20°C)	<table border="1"> <tr> <td>WV</td> <td>6.3</td> <td>10</td> <td>16</td> <td>25</td> <td>35</td> </tr> <tr> <td>tanδ</td> <td>0.22</td> <td>0.19</td> <td>0.16</td> <td>0.14</td> <td>0.12</td> </tr> </table> <p>When nominal capacitance is over 1000uF, Tanδ shall be added 0.02 to the listed value with increase of every 1000uF.</p>	WV	6.3	10	16	25	35	tanδ	0.22	0.19	0.16	0.14	0.12												
WV	6.3	10	16	25	35																				
tanδ	0.22	0.19	0.16	0.14	0.12																				
Low Temperature Stability Impedance Ratio (MAX)	<table border="1"> <tr> <td>Z(120Hz) \ WV</td> <td>6.3</td> <td>10</td> <td>16</td> <td>25</td> <td>35</td> </tr> <tr> <td>Z-25°C / Z+20°C</td> <td>4</td> <td>3</td> <td>2</td> <td>2</td> <td>2</td> </tr> <tr> <td>Z-40°C / Z+20°C</td> <td>8</td> <td>6</td> <td>4</td> <td>3</td> <td>3</td> </tr> </table>	Z(120Hz) \ WV	6.3	10	16	25	35	Z-25°C / Z+20°C	4	3	2	2	2	Z-40°C / Z+20°C	8	6	4	3	3						
Z(120Hz) \ WV	6.3	10	16	25	35																				
Z-25°C / Z+20°C	4	3	2	2	2																				
Z-40°C / Z+20°C	8	6	4	3	3																				
Endurance	<p>After applying rated voltage with rated ripple current for 4000~10000hours at 105°C , the capacitors shall meet the following requirements.</p> <table border="1"> <tr> <td>Capacitance Change</td> <td colspan="3">Within ± 25 % of initial value</td> </tr> <tr> <td>Dissipation Factor</td> <td colspan="3">200% or less of initial specified value</td> </tr> <tr> <td>Leakage Current</td> <td colspan="3">initial specified value or less</td> </tr> <tr> <td>VDC</td> <td>φ5~6.3φ</td> <td>φ8~10φ</td> <td>φ12.5~18φ</td> </tr> <tr> <td>6.3~10(V)</td> <td>4000hrs</td> <td>6000hrs</td> <td>8000hrs</td> </tr> <tr> <td>16~100(V)</td> <td>5000hrs</td> <td>7000hrs</td> <td>10000hrs</td> </tr> </table>	Capacitance Change	Within ± 25 % of initial value			Dissipation Factor	200% or less of initial specified value			Leakage Current	initial specified value or less			VDC	φ5~6.3φ	φ8~10φ	φ12.5~18φ	6.3~10(V)	4000hrs	6000hrs	8000hrs	16~100(V)	5000hrs	7000hrs	10000hrs
Capacitance Change	Within ± 25 % of initial value																								
Dissipation Factor	200% or less of initial specified value																								
Leakage Current	initial specified value or less																								
VDC	φ5~6.3φ	φ8~10φ	φ12.5~18φ																						
6.3~10(V)	4000hrs	6000hrs	8000hrs																						
16~100(V)	5000hrs	7000hrs	10000hrs																						
Shelf Life	After placed at 105°C without voltage applied for 1000 hours, the capacitors shall meet the same requirement as load life.																								

Diagram of Dimensions

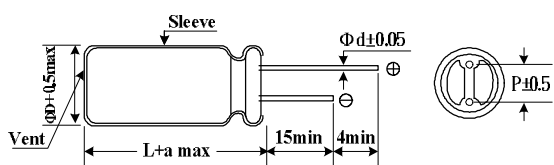

ψD	5	6.3	8	10	13	16	18
P	2.0	2.5	3.5	5.0	5.0	7.5	7.5
ψd	0.5	0.5	0.6	0.6	0.6	0.8	0.8
a	1.5	1.5	1.5	1.5	2.0	2.0	2.0

Multiplier for Ripple Current

Frequency coefficient

Cap(μF) \ Freq. (Hz)	120	1K	10K	100K
6.8 to 180	0.40	0.75	0.90	1.00
220 to 560	0.50	0.85	0.94	1.00
680 to 1800	0.60	0.87	0.95	1.00
2200 to 3900	0.75	0.90	0.95	1.00
4700μF Higher	0.85	0.95	0.98	1.00

ALUMINUM ELECTROLYTIC CAPACITORS

TA Low Impedance & Long Life Series

■ Dimensions, Rated Ripple Current, Max Impedance

Capacitance (μF)	Rated (Surge) Voltage															
	6.3V (8)			10V (13)			16V (20)			25V (32)			35V (44)			
	SIZE	Ripple	Z	SIZE	Ripple	Z	SIZE	Ripple	Z	SIZE	Ripple	Z	SIZE	Ripple	Z	
33													5x11	210	0.58	
47										5x11	210	0.58				
56							5x11	210	0.58				6.3x11	340	0.22	
100				5x11	210	0.58				6.3x11	340	0.22				
120							6.3x11	340	0.22							
150	5x11	210	0.58										8x11	640	0.13	
220				6.3x11	340	0.220					8x11	640	0.13	8x15	840	0.087
													10x12.5	865	0.080	
270													8x20	1050	0.069	
330	6.3x11	340	0.22				8x11	640	0.130	8x15	840	0.087	10x15	1210	0.060	
										10x12.5	865	0.080				
470				8x11	640	0.130	8x15	840	0.087	8x20	1050	0.069	10x20	1400	0.046	
							10x12.5	865	0.080	10x15	1210	0.060	13x16	1450	0.049	
560													10x25	1650	0.042	
680	8x11	640	0.13	8x15	840	0.087	8x20	1050	0.069	10x20	1400	0.046	10x30	1910	0.031	
				10x12.5	865	0.080	10x15	1210	0.060	13x16	1450	0.049	13x20	1900	0.035	
820	10x12.5	865	0.080								10x25	1650	0.042			
1000	8x15	840	0.087	8x20	1050	0.069	10x20	1400	0.046	10x30	1910	0.031	13x25	2230	0.027	
				10x15	1210	0.060	13x16	1450	0.049	13x20	1900	0.035				
1200	8x20	1050	0.069	10x20	1400	0.046	10x25	1650	0.042				13x30	2650	0.024	
	10x15	1210	0.060										16x20	2530	0.027	
1500	10x20	1400	0.046	10x25	1650	0.042	10x30	1910	0.031	13x25	2230	0.027	13x35	2880	0.020	
				13x16	1450	0.049	13x20	1900	0.035							
1800	13x16	1450	0.049							13x30	2650	0.024	13x40	3350	0.017	
										16x20	2530	0.027	16x25	2930	0.021	
													18x20	2860	0.026	
2200	10x25	1650	0.042	10x30	1910	0.031	13x25	2230	0.027	13x35	2880	0.020	16x32	3450	0.017	
				13x20	1900	0.035				18x20	2860	0.026	18x25	3140	0.019	
2700	10x30	1910	0.031				13x30	2650	0.024	13x40	3350	0.017	16x36	3610	0.015	
							16x20	2530	0.027	16x25	2930	0.021	18x32	4170	0.015	
3300	13x20	1900	0.035	13x25	2230	0.027	13x35	2880	0.020	16x32	3450	0.017	16x40	4080	0.013	
										18x25	3140	0.019	18x36	4220	0.014	
3900	13x25	2230	0.027	13x30	2650	0.024	13x40	3350	0.017	16x36	3610	0.015	18x40	4280	0.012	
				16x20	2530	0.027	16x25	2930	0.021	18x32	4170	0.015				
							18x20	2860	0.026							
4700	13x30	2650	0.024	13x35	2880	0.020	16x32	3450	0.017	16x40	4080	0.013				
							18x25	3140	0.019	18x36	4220	0.014				
5600	13x35	2880	0.020	13x40	3350	0.017	16x36	3610	0.015	18x40	4280	0.012				
	16x20	2530	0.027	16x25	2930	0.021	18x32	4170	0.015							
				18x20	2860	0.026										
6800	13x40	3350	0.017	16x32	3450	0.017	16x40	4080	0.013							
	16x25	2930	0.021	18x25	3140	0.019										
	18x20	2860	0.026													
8200	16x32	3450	0.017	16x36	3610	0.015	18x36	4220	0.014							
				18x32	4170	0.015										

☆ Size: D \times L (mm) ☆ Ripple Current: (mA/rms), 105°C, 100KHz ☆ Impedance (Ω), 20°C, 100KHz

ALUMINUM ELECTROLYTIC CAPACITORS

ST Low Impedance & Long Life Series

- Features : 105°C 4000~10000hrs Low Impedance and long Life
- Recommended Applications:
Applicable for SMPS, Adaptor, Charger, Monitor/Computer
- Corresponding product to RoHS



Specifications

Item	Characteristics																																				
Operating Temperature Range	-40 ~ +105°C																																				
Rated Voltage Range	6.3~100VDC																																				
Rated Capacitance Range	2.2 ~ 15000μF																																				
Capacitance Tolerance	± 20 % at 120Hz , 20°C																																				
Leakage Current (MAX) (20°C)	I=0.01CV or 3(μA) , whichever is greater. (After rated voltage applied for 2 minutes) I= Leakage Current (μA) C= Nominal Capacitance (μF) V= Rated Voltage (V) (20°C)																																				
Dissipation Factor (MAX) (tanδ) (120Hz ,20°C)	<table border="1"> <thead> <tr> <th>WV</th> <th>6.3</th> <th>10</th> <th>16</th> <th>25</th> <th>35</th> <th>50</th> <th>63</th> <th>100</th> </tr> </thead> <tbody> <tr> <td>tanδ</td> <td>0.22</td> <td>0.19</td> <td>0.16</td> <td>0.14</td> <td>0.12</td> <td>0.14</td> <td>0.14</td> <td>0.14</td> </tr> </tbody> </table>	WV	6.3	10	16	25	35	50	63	100	tanδ	0.22	0.19	0.16	0.14	0.12	0.14	0.14	0.14																		
	WV	6.3	10	16	25	35	50	63	100																												
tanδ	0.22	0.19	0.16	0.14	0.12	0.14	0.14	0.14																													
When nominal capacitance is over 1000uF, Tanδ shall be added 0.02 to the listed value with increase of every 1000uF. Down size tanδ add 3%.																																					
Low Temperature Stability Impedance Ratio (MAX)	<table border="1"> <thead> <tr> <th>WV</th> <th>6.3</th> <th>10</th> <th>16</th> <th>25</th> <th>35</th> <th>50</th> <th>63</th> <th>100</th> </tr> </thead> <tbody> <tr> <td>Z(120Hz)</td> <td></td> <td></td> <td></td> <td></td> <td></td> <td></td> <td></td> <td></td> </tr> <tr> <td>Z-25°C / Z+20°C</td> <td>4</td> <td>3</td> <td>2</td> <td>2</td> <td>2</td> <td>2</td> <td>2</td> <td>2</td> </tr> <tr> <td>Z-40°C / Z+20°C</td> <td>8</td> <td>6</td> <td>4</td> <td>3</td> <td>3</td> <td>3</td> <td>3</td> <td>3</td> </tr> </tbody> </table>	WV	6.3	10	16	25	35	50	63	100	Z(120Hz)									Z-25°C / Z+20°C	4	3	2	2	2	2	2	2	Z-40°C / Z+20°C	8	6	4	3	3	3	3	3
	WV	6.3	10	16	25	35	50	63	100																												
	Z(120Hz)																																				
Z-25°C / Z+20°C	4	3	2	2	2	2	2	2																													
Z-40°C / Z+20°C	8	6	4	3	3	3	3	3																													
After applying rated voltage with rated ripple current for 4000~10000hours at 105°C, the capacitors shall meet the following requirements.																																					
Endurance	Capacitance Change	Within ± 25 % of initial value																																			
	Dissipation Factor	200% or less of initial specified value																																			
	Leakage Current	initial specified value or less																																			
	VDC	φ5~6.3φ	φ8~10φ	φ12.5~18φ																																	
	6.3~10(V)	4000hrs	6000hrs	8000hrs																																	
16~100(V)	5000hrs	7000hrs	10000hrs																																		
Shelf Life	After placed at 105°C without voltage applied for 1000 hours, the capacitors shall meet the same requirement as load life.																																				

Diagram of Dimensions

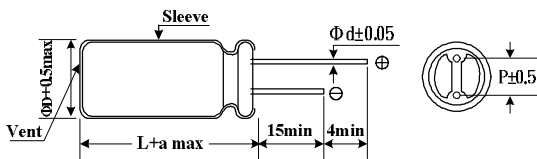

ψD	5	6.3	8	10	13	16	18
P	2.0	2.5	3.5	5.0	5.0	7.5	7.5
ψd	0.5	0.5	0.6	0.6	0.6	0.8	0.8
a	1.5	1.5	1.5	1.5	2.0	2.0	2.0

Multiplier for Ripple Current

Frequency coefficient

Cap(μF) \ Freq. (Hz)	120	1K	10K	100K
6.8to180	0.40	0.75	0.90	1.00
220to560	0.50	0.85	0.94	1.00
680to1800	0.60	0.87	0.95	1.00
2200to3900	0.75	0.90	0.95	1.00
4700μF Higher	0.85	0.95	0.98	1.00

ALUMINUM ELECTROLYTIC CAPACITORS

ST Low Impedance & Long Life Series

■ Dimensions, Rated Ripple Current

Capacitance (μF)	Rated Voltage(V)											
	6.3			10			16			25		
	Size	Ripple	ESR	Size	Ripple	ESR	Size	Ripple	ESR	Size	Ripple	ESR
47												
56							5x11	210	0.720	5x11	210	0.720
100				5x11	210	0.72	6.3x11	340	0.380	6.3x11	340	0.380
150	5x11	210	0.720							8x11	640	0.200
220				6.3x11	340	0.38	8x11	640	0.200	8x11	640	0.200
330	6.3x11	340	0.380				8x15	701	0.160	8x15	840	0.160
470				8x11	640	0.200	8x15	840	0.160	10x15	1210	0.084
680	8x11	640	0.200	8x15	840	0.160	10x15	1210	0.084	10x20	1400	0.062
820	8x15	840	0.160							10x25	1650	0.052
1000	10x12	865	0.120	10x15	1210	0.084	10x20	1400	0.062	13x20	1900	0.046
1500	8x20	1050	0.110	10x20	1400	0.062	10x25	1650	0.052	13x25	2230	0.034
	10x15	1210	0.084									
2200	10x20	1400	0.062	10x25	1650	0.052	13x25	2230	0.034	13x35	2880	0.027
2700	10x25	1650	0.052	13x20	1900	0.046	13x30	2650	0.030	16x25	2930	0.028
3300	13x20	1900	0.046	13x25	2230	0.034	13x35	2880	0.027	16x32	3450	0.025
3900	13x25	2230	0.034	13x30	2650	0.030	13x40	3350	0.024	18x32	4170	0.015
4700	13x30	2650	0.030	13x35	2880	0.027	16x32	3450	0.028	18x36	4280	0.014
5600	13x35	2880	0.027	13x40	3350	0.024	16x36	3610	0.018			
				16x25	2930	0.028	18x32	4170	0.015			
6800	13x40	3350	0.024	16x32	3450	0.025	18x36	4220	0.014			
	16x25	2930	0.028									
8200	16x32	3450	0.025	16x36	3610	0.018						
10000	16x36	3610	0.018	18x36	4220	0.014						
12000	18x32	4170	0.015									
15000	18x36	4220	0.014									

Capacitance (μF)	Rated Voltage(V)											
	35			50			63			100		
	Size	Ripple	ESR	Size	Ripple	ESR	Size	Ripple	ESR	Size	Ripple	ESR
2.2										5x11	20	10.00
3.3										5x11	27	8.500
4.7										5x11	30	8.000
6.8										5x11	45	7.500
10				5x11	120	3.50	5x11	55	2.300	6.3x11	55	5.000
15										6.3x11	70	5.000
22				5x11	210	2.300				8x11	85	2.700
33	5x11	210	0.720	6.3x11	340	1.200	6.3x11	115	1.200	8x11	95	2.500
47	6.3x11	340	0.380	6.3x11	340	1.200				8x15	150	1.800
56							8x11	232	0.630	8x20	200	1.500
68										10x15	230	1.300
82										10x20	250	1.200
100				8x11	555	0.630				10x20	330	0.950
120				8x15	730	0.450	10x16	357	0.310	10x25	400	0.800
150	8x11	640	0.200	8x20	910	0.330				13x20	460	0.900
180							10x20	466	0.210			
220	8x15	840	0.160	10x16	1050	0.310	10x25	531	0.200	13x25	640	0.600
270							10x30	663	0.150			
							13x20	690	0.160			
330	10x20	1400	0.062	10x20	1400	0.210	13x25	784	0.120	16x25	720	0.570
470	10x25	1650	0.052	10x30	1690	0.150	13x30	905	0.100	16x32	770	0.550
				13x20	1660	0.160				18x25	840	0.500
560				13x25	1950	0.120	13x35	1050	0.083			
680	10x30	1910	0.044	13x30	2310	0.100	13x40	1180	0.071	18x36	1400	0.180
	13x20	1900	0.046									
820	13x25	2230	0.045	13x35	2510	0.083	16x32	1570	0.054	18x40	1850	0.130
1000	13x25	2230	0.045	16x25	2555	0.073	16x36	1790	0.045	18x40	1850	0.130
1200	13x30	2650	0.030	16x32	3010	0.054	16x40	2020	0.040			
1500	13x35	2880	0.027	16x36	3150	0.045						
1800	13x40	3350	0.024	18x32	3635	0.047						
2200	16x32	3450	0.025	18x36	3680	0.040						
2700	16x36	3610	0.022	18x40	3800	0.036						
3300	18x36	4220	0.020									

☆ Size: Dφx L (mm) ☆ Ripple Current: 105℃, 100KHz(mA/rms) ☆ ESR(Ω): 25℃, 100KHz

ALUMINUM ELECTROLYTIC CAPACITORS

TC Low Impedance & Long Life Series



- Features : 105°C 6000~10000hrs Low Impedance and long Life
- Recommended Applications: Applicable for AV(TV, Video, Audio), OA/HA/Communication, SMPS, Adapter, Monitor/Computer, Converter/Inverter
- Corresponding product to RoHS

TC
 ↑ Long Life
TB

Specifications

Item	Characteristics																																								
Operating Temperature Range	-40 ~ +105°C																																								
Rated Voltage Range	6.3~100VDC																																								
Rated Capacitance Range	8.2 ~ 8200µF																																								
Capacitance Tolerance	± 20 % at 120Hz , 20°C																																								
Leakage Current (MAX) (20°C)	I=0.01CV or 3(µA) , whichever is greater. (After rated voltage applied for 2 minutes) I = Leakage Current (µA) C= Nominal Capacitance (µF) V= Rated Voltage (V) (20°C)																																								
Dissipation Factor (MAX) (tanδ) (120Hz ,20°C)	<table border="1" style="margin: auto;"> <tr> <th>WV</th> <td>6.3</td> <td>10</td> <td>16</td> <td>25</td> <td>35</td> <td>50</td> <td>63</td> <td>80</td> <td>100</td> </tr> <tr> <th>tanδ</th> <td>0.22</td> <td>0.19</td> <td>0.16</td> <td>0.14</td> <td>0.12</td> <td>0.10</td> <td>0.09</td> <td>0.08</td> <td>0.08</td> </tr> </table>	WV	6.3	10	16	25	35	50	63	80	100	tanδ	0.22	0.19	0.16	0.14	0.12	0.10	0.09	0.08	0.08																				
	WV	6.3	10	16	25	35	50	63	80	100																															
tanδ	0.22	0.19	0.16	0.14	0.12	0.10	0.09	0.08	0.08																																
When nominal capacitance is over 1000µF, Tanδ shall be added 0.02 to the listed value with increase of every 1000µF.																																									
Low Temperature Stability Impedance Ratio (MAX)	<table border="1" style="margin: auto;"> <tr> <th>WV</th> <td>6.3</td> <td>10</td> <td>16</td> <td>25</td> <td>35</td> <td>50</td> <td>63</td> <td>80</td> <td>100</td> </tr> <tr> <th>Z(120Hz)</th> <td></td> <td></td> <td></td> <td></td> <td></td> <td></td> <td></td> <td></td> <td></td> </tr> <tr> <th>Z-25°C / Z+20°C</th> <td>2</td> <td>2</td> <td>2</td> <td>2</td> <td>2</td> <td>2</td> <td>2</td> <td>2</td> <td>2</td> </tr> <tr> <th>Z-40°C / Z+20°C</th> <td>3</td> <td>3</td> <td>3</td> <td>3</td> <td>3</td> <td>3</td> <td>3</td> <td>3</td> <td>3</td> </tr> </table>	WV	6.3	10	16	25	35	50	63	80	100	Z(120Hz)										Z-25°C / Z+20°C	2	2	2	2	2	2	2	2	2	Z-40°C / Z+20°C	3	3	3	3	3	3	3	3	3
	WV	6.3	10	16	25	35	50	63	80	100																															
	Z(120Hz)																																								
Z-25°C / Z+20°C	2	2	2	2	2	2	2	2	2																																
Z-40°C / Z+20°C	3	3	3	3	3	3	3	3	3																																
After applying rated voltage with rated ripple current for 6000~10000hours at 105°C, the capacitors shall meet the following requirements.																																									
Endurance	Capacitance Change	Within ± 25 % of initial value(6.3v,10v:±30%)																																							
	Dissipation Factor	200% or less of initial specified value																																							
	Leakage Current	initial specified value or less																																							
	<table border="1" style="margin: auto;"> <tr> <th>Dφ</th> <td>5-6.3φ</td> <td>φ8</td> <td>φ10~18φ</td> </tr> <tr> <th>Life</th> <td>6000hrs</td> <td>8000hrs</td> <td>10000hrs</td> </tr> </table>	Dφ	5-6.3φ	φ8	φ10~18φ	Life	6000hrs	8000hrs	10000hrs																																
Dφ	5-6.3φ	φ8	φ10~18φ																																						
Life	6000hrs	8000hrs	10000hrs																																						
Shelf Life	After placed at 105°C without voltage applied for 1000 hours, the capacitors shall meet the same requirement as load life.																																								

Diagram of Dimensions

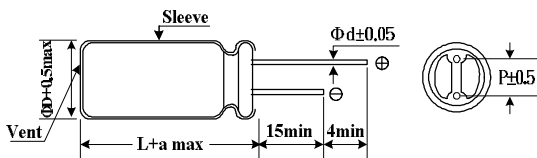

ψD	5	6.3	8	10	13	16	18
P	2.0	2.5	3.5	5.0	5.0	7.5	7.5
ψd	0.5	0.5	0.6	0.6	0.6	0.8	0.8
a	1.5	1.5	1.5	1.5	2.0	2.0	2.0

Multiplier for Ripple Current

Frequency coefficient					
Cap(µF)	Freq. (Hz)	120	1K	10K	100K
8.2 to 33		0.42	0.70	0.90	1.00
47 to 270		0.50	0.73	0.92	1.00
330 to 680		0.55	0.77	0.94	1.00
820 to 1800		0.60	0.80	0.96	1.00
2200 to 8200		0.70	0.85	0.98	1.00

ALUMINUM ELECTROLYTIC CAPACITORS

TC

Low Impedance & Long Life Series

■ Dimensions, Rated Ripple Current, Max Impedance

Capacitance (μ F)	Rated (Surge) Voltage								
	6.3V (8)			10V (13)			16V (20)		
	SIZE	Ripple	Z	SIZE	Ripple	Z	SIZE	Ripple	Z
100							5x11	345	0.242
150				5x11	345	0.242			
220	5x11	345	0.242				6.3x11	540	0.103
330				6.3x11	540	0.103			
470	6.3x11	540	0.103				8x12	945	0.062
680				8x12	945	0.062	8x16	1250	0.050
							10X12.5	1330	0.043
820	8x12	945	0.062						
1000				8x16	1250	0.050	8x20	1500	0.032
				10X12.5	1330	0.043	10X16	1760	0.031
1200	8x16	1250	0.050						
	10X12.5	1330	0.043						
1500	8x20	1500	0.032	8x20	1500	0.032	10X20	1960	0.022
				10x16	1760	0.031			
1800	10x16	1760	0.031	10x20	1960	0.022	10x25	2250	0.020
2200	10x20	1960	0.022	10x25	2250	0.020	13x20	2480	0.019
2700	10x25	2250	0.020				13x25	2900	0.017
3300				13x20	2480	0.019	13x30	3450	0.014
							16x20	3250	0.017
3900	13x20	2480	0.019	13x25	2900	0.017	13x35	3570	0.013
4700	13x25	2900	0.017	13X30	3450	0.014	16x25	3630	0.014
				16x20	3250	0.017			
5600	13X30	3450	0.014	13x35	3570	0.013			
6800	16x20	3250	0.017	16x25	3630	0.014			
	13x35	3570	0.013						
8200	16x25	3630	0.014						

☆ Size: D ϕ x L (mm) ☆ Ripple Current: (mA/rms), 105°C, 100KHz ☆ Impedance (Ω), 20°C, 100KHz

ALUMINUM ELECTROLYTIC CAPACITORS

TC

Low Impedance & Long Life Series

■ Dimensions, Rated Ripple Current, Max Impedance

Capacitance (μ F)	Rated (Surge) Voltage								
	25V (32)			35V (44)			50V (63)		
	SIZE	Ripple	Z	SIZE	Ripple	Z	SIZE	Ripple	Z
27							5x11	238	0.3400
47				5x11	345	0.2200			
56							6.3x11	385	0.1400
68	5x11	345	0.242						
100				6.3x11	540	0.094	8x12	724	0.074
120							8x16	950	0.061
150	6.3x11	540	0.103				10x12.5	979	0.061
180							8x20	1190	0.046
220				8x12	945	0.056	10x16	1370	0.042
270				8x16	1250	0.045	10x20	1580	0.030
330	8x12	945	0.062	10x12.5	1330	0.039	10x25	1870	0.028
390	8x16	1250	0.050	8x20	1500	0.029			
470	10x12.5	1330	0.043	10x16	1760	0.028	13x20	2050	0.027
560	8x20	1500	0.032	10x20	1960	0.020	13x25	2410	0.023
680	10x16	1760	0.031	10x25	2250	0.018	13x30	2860	0.021
820	10x20	1960	0.022				13x35	2960	0.019
							16x20	2730	0.023
1000	10x25	2250	0.020	13x20	2480	0.017	16x25	3010	0.021
1200				13x25	2900	0.015			
1500	13x20	2480	0.019	13x30	3450	0.013			
				16x20	3250	0.015			
1800	13x25	2900	0.017	13x35	3570	0.012			
2200	13x30	3450	0.014	16x25	3630	0.013			
	16x20	3250	0.017						
2700	13x35	3570	0.013						
3300	16x25	3630	0.014						

☆ Size: D ϕ x L (mm) ☆ Ripple Current: (mA/rms), 105°C, 100KHz ☆ Impedance (Ω), 20°C, 100KHz

ALUMINUM ELECTROLYTIC CAPACITORS

TC

Low Impedance & Long Life Series

■ Dimensions, Rated Ripple Current, Max Impedance

Capacitance (μF)	Rated (Surge) Voltage								
	63V (79)			80V (100)			100V (125)		
	SIZE	Ripple	Z	SIZE	Ripple	Z			
8.2							5×11	163	1.400
12				5×11	163	1.400			
18	5×11	173	1.000				6.3×11	267	0.570
33				6.3×11	267	0.570	8×12	462	0.360
47	6.3×11	278	0.560				8×16	585	0.250
56				8×12	462	0.360	10×12.5	624	0.230
68				8×16	585	0.250	8×20	735	0.190
82	8×12	525	0.264	10×12.5	624	0.230	10×16	780	0.170
100	8×16	688	0.192	8×20	735	0.190	10×20	1040	0.120
							13×16	975	0.130
120	10×12.5	725	0.180	10×16	780	0.170	10×25	1170	0.110
150	8×20	861	0.144				13×20	1430	0.085
180	10×16	998	0.132	10×20	1040	0.120			
				13×16	975	0.130			
220				10×25	1170	0.110	13×25	1620	0.060
270	10×20	1200	0.094	13×20	1430	0.085	13×30	1950	0.051
	13×16	1200	0.098				16×20	1750	0.058
330	10×25	1410	0.083	13×25	1620	0.060	13×35	2140	0.043
390	13×20	1570	0.072	13×30	1950	0.051	13×40	2340	0.036
				16×20	1750	0.058	16×25	2210	0.044
							18×20	1950	0.054
470	13×25	1990	0.052	13×35	2140	0.043	16×32	2400	0.033
							18×25	2270	0.038
560	13×30	2410	0.042	13×40	2340	0.036	16×36	2600	0.029
	16×20	2100	0.052	16×25	2210	0.044	18×32	2470	0.031
				18×20	1950	0.054			
680	13×35	2620	0.040	16×32	2400	0.033	16×40	2860	0.027
							18×36	2860	0.027
820	13×40	2940	0.032	16×36	2600	0.029	18×40	3510	0.026
	16×25	2730	0.038	18×25	2270	0.038			
	18×20	2500	0.046						
1000				16×40	2860	0.027			
				18×32	2470	0.031			
1200	16×32	2990	0.029	18×36	2860	0.027			
	18×25	2800	0.037						
1500	16×36	3040	0.025	18×40	3510	0.026			
	18×32	3300	0.030						
1800	16×40	3570	0.023						
	18×36	3570	0.024						
2200	18×40	3670	0.022						

☆ Size: D φ x L (mm) ☆ Ripple Current: (mA/rms), 105°C, 100KHz ☆ Impedance (Ω), 20°C, 100KHz

ALUMINUM ELECTROLYTIC CAPACITORS

SZ Ultra Low ESR Series

- Features: 105°C 1000~2000 hours ,Lower ESR and higher ripple current
- Recommended Applications: Applicable for switching regulator of computer, especially for high frequency
- Corresponding product to RoHS

SZ
↑ Low E.S.R
SC

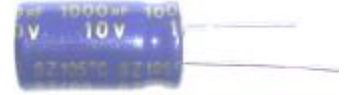

Specifications

Item	Characteristics																
Operating Temperature Range	-40 ~ +105°C																
Rated Voltage Range	6.3 ~ 16VDC																
Rated Capacitance Range	470 ~ 3300 µF																
Capacitance Tolerance	± 20 % at 120Hz , 20°C																
Leakage Current (MAX)(20°C)	I=0.03CV ,(After rated voltage applied for 2 minutes)																
Dissipation Factor (MAX) (tanδ) (120Hz ,20°C)	<table border="1"> <thead> <tr> <th>WV</th> <th>6.3</th> <th>10</th> <th>16</th> </tr> </thead> <tbody> <tr> <td>tanδ</td> <td>0.22</td> <td>0.19</td> <td>0.16</td> </tr> </tbody> </table>	WV	6.3	10	16	tanδ	0.22	0.19	0.16								
	WV	6.3	10	16													
tanδ	0.22	0.19	0.16														
When nominal capacitance is over 1000µF, tanδ shall be added 0.02 to the listed value with increase of every 1000µF.																	
Low Temperature Stability Impedance Ratio (MAX)	<table border="1"> <thead> <tr> <th>WV</th> <th>6.3</th> <th>10</th> <th>16</th> </tr> </thead> <tbody> <tr> <td>Z(120Hz)</td> <td>6.3</td> <td>10</td> <td>16</td> </tr> <tr> <td>Z-25°C / Z+20°C</td> <td>2</td> <td>2</td> <td>2</td> </tr> <tr> <td>Z-40°C / Z+20°C</td> <td>3</td> <td>3</td> <td>3</td> </tr> </tbody> </table>	WV	6.3	10	16	Z(120Hz)	6.3	10	16	Z-25°C / Z+20°C	2	2	2	Z-40°C / Z+20°C	3	3	3
	WV	6.3	10	16													
	Z(120Hz)	6.3	10	16													
Z-25°C / Z+20°C	2	2	2														
Z-40°C / Z+20°C	3	3	3														
After applying rated voltage with ripple current for 2000 hours at 105°C, the capacitors shall meet the following requirements.																	
Endurance	<table border="1"> <tbody> <tr> <td>Capacitance Change</td> <td>Within ± 25 % of initial value</td> </tr> <tr> <td>Dissipation Factor</td> <td>Not more than 200% of specified value</td> </tr> <tr> <td>Leakage Current</td> <td>Not more than the specified value</td> </tr> </tbody> </table>	Capacitance Change	Within ± 25 % of initial value	Dissipation Factor	Not more than 200% of specified value	Leakage Current	Not more than the specified value										
	Capacitance Change	Within ± 25 % of initial value															
	Dissipation Factor	Not more than 200% of specified value															
Leakage Current	Not more than the specified value																
*If dimension is down size,Endurance will be less 1000 hours than standard.																	
Shelf Life	After placed at 105°C without voltage applied for 1000 hours, the capacitors shall meet the same requirement as Endurance.																

Diagram of Dimensions

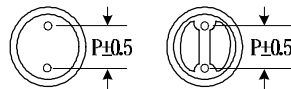
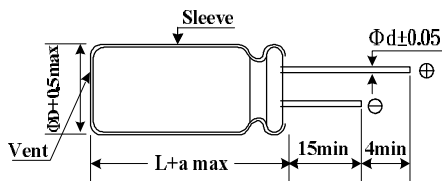

ψD	8	10
P	3.5	5.0
ψd	0.6	0.6
a	1.5	1.5

Multiplier for Ripple Current

Frequency coefficient

Frequency (Hz)	120	1K	10K	100K
Factor	0.5	0.8	0.9	1.0

ALUMINUM ELECTROLYTIC CAPACITORS

SZ

Ultra Low ESR
Series

■ Dimensions, Rated Ripple Current, Equivalent Series Resistance

Rated (Surge) Voltage 6.3V (8)			
CAP (μ F)	D x L (mm)	Ripple Current (mA/ rms 105°C / 100KHz)	ESR (m Ω Max 20°C / 100KHz)
820	8 x 11	1036	43
1200	8 x 15	1355	34
1500	8 x 20	1740	25
	10 x 12.5	1400	31
1800	10 x 16	1818	23
2200	10 x 20	2318	15
3300	10 x 25	2364	14

Rated (Surge) Voltage 10V (13)			
CAP (μ F)	D x L (mm)	Ripple Current (mA/ rms 105°C / 100KHz)	ESR (m Ω Max 20°C / 100KHz)
680	8 x 11	1036	43
1000	8 x 15	1355	34
	10 x 12.5	1400	31
1500	8 x 20	1700	25
	10 x 16	1818	23
1800	10 x 20	2318	16
2200	10 x 25	2545	14

Rated (Surge) Voltage 16V (20)			
CAP (μ F)	D x L (mm)	Ripple Current (mA/ rms 105°C / 100KHz)	ESR (m Ω Max 20°C / 100KHz)
470	8 x 11	1036	43
680	8 x 15	1355	34
	10 x 12.5	1400	31
1000	8 x 20	1700	25
	10 x 16	1818	23
1500	10 x 20	2318	16
1800	10 x 25	2546	14

☆ Size: D \times L (mm) ☆ Ripple Current: (mA/rms), 105°C, 100KHz ☆ ESR (m Ω), 20°C, 100KHz

ALUMINUM ELECTROLYTIC CAPACITORS

AK Series Higher temperature range & Long Life

- Features : 125°C 2000~5000hrs · High Temperature and Long Life
- Recommended Applications:
Applicable for Electronic Ballast, Lighting Ballast
- Corresponding product to RoHS

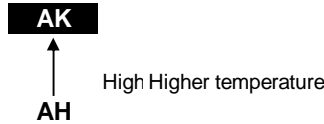

Specifications

Item	Characteristics																																					
Operating Temperature Range	-40 ~ +125°C	-25 ~ +125°C																																				
Rated Voltage Range	10~63VDC	160~450VDC																																				
Rated Capacitance Range	47~ 4700µF	1~150µF																																				
Capacitance Tolerance	± 20 % at 120Hz , 20°C																																					
Leakage Current (MAX) (20°C)	I=0.01CV or 3(µA) ,whichever is greater.																																					
	I=0.1CV+40 µA (CV ≤ 1000) I=0.04CV+100 µA (CV > 1000)																																					
Dissipation Factor (MAX) (tanδ) (120Hz ,20°C)	(After rated voltage applied for 2 minutes) I= Leakage Current (µA) C= Nominal Capacitance (µF) V= Rated Voltage (V) (20°C)																																					
	<table border="1"> <thead> <tr> <th>WV</th> <th>10</th> <th>16</th> <th>25</th> <th>35</th> <th>50</th> <th>63</th> <th>160~250</th> <th>350~450</th> </tr> </thead> <tbody> <tr> <td>tanδ</td> <td>0.19</td> <td>0.16</td> <td>0.14</td> <td>0.12</td> <td>0.14</td> <td>0.14</td> <td>0.20</td> <td>0.24</td> </tr> </tbody> </table> <p>When nominal capacitance is over 1000uF, tanδ shall be added 0.02 to the listed value with increase of every 1000uF. Down Size tanδ added 0.03.</p>	WV	10	16	25	35	50	63	160~250	350~450	tanδ	0.19	0.16	0.14	0.12	0.14	0.14	0.20	0.24																			
WV	10	16	25	35	50	63	160~250	350~450																														
tanδ	0.19	0.16	0.14	0.12	0.14	0.14	0.20	0.24																														
Low Temperature Stability Impedance Ratio (MAX)	<table border="1"> <thead> <tr> <th>WV</th> <th>10</th> <th>16</th> <th>25</th> <th>35</th> <th>50</th> <th>63</th> <th>160~250</th> <th>350~450</th> </tr> </thead> <tbody> <tr> <td>Z(120Hz)</td> <td></td> <td></td> <td></td> <td></td> <td></td> <td></td> <td></td> <td></td> </tr> <tr> <td>Z-25°C / Z+20°C</td> <td>3</td> <td>2</td> <td>2</td> <td>2</td> <td>2</td> <td>2</td> <td>3</td> <td>6</td> </tr> <tr> <td>Z-40°C / Z+20°C</td> <td>6</td> <td>4</td> <td>4</td> <td>4</td> <td>4</td> <td>3</td> <td>-</td> <td>-</td> </tr> </tbody> </table>	WV	10	16	25	35	50	63	160~250	350~450	Z(120Hz)									Z-25°C / Z+20°C	3	2	2	2	2	2	3	6	Z-40°C / Z+20°C	6	4	4	4	4	3	-	-	
	WV	10	16	25	35	50	63	160~250	350~450																													
	Z(120Hz)																																					
Z-25°C / Z+20°C	3	2	2	2	2	2	3	6																														
Z-40°C / Z+20°C	6	4	4	4	4	3	-	-																														
Endurance	After applying rated voltage for 2000~5000hours at 125°C , the capacitors shall meet the following requirements.																																					
	Capacitance Change	Within ± 30 % of initial value	Within ± 20 % of initial value																																			
	Dissipation Factor	≤ 300% of initial specified value	≤ 200% of the initial specified value																																			
	Leakage Current	≤ initial specified value or less	≤ initial specified value																																			
	8Φ	10Φ	≥ 13Φ																																			
	2000Hrs	3000Hrs	5000Hrs																																			
Shelf Life	After leaving capacitors under no load at 125°C for 1000 hours.																																					
	Capacitance Change	Within ± 30 % of initial value	Within ± 20 % of initial value																																			
	Dissipation Factor	≤ 300% of initial specified value	≤ 200% of the initial specified value																																			
	Leakage Current	≤ 500% of initial specified value	≤ 500% of the initial specified value																																			

Diagram of Dimensions

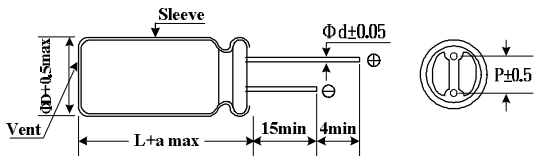

ψD	8	10	13	16	18
P	3.5	5.0	5.0	7.5	7.5
ψd	0.6	0.6	0.6	0.8	0.8
a	1.5	1.5	2.0	2.0	2.0

Multiplier for Ripple Current

Frequency coefficient

Frequency (Hz)		120	1K	10K	50K~100K
10~63WV	CAP ≤ 10	0.40	0.75	0.90	1.00
	10 < CAP ≤ 100	0.50	0.85	0.95	1.00
	100 < CAP ≤ 1000	0.60	0.88	0.96	1.00
	1000 < CAP	0.75	0.90	0.98	1.00
160~450WV	CAP ≤ 33	1.00	1.50	1.75	1.80
	CAP ≥ 47	1.00	1.30	1.40	1.50

ALUMINUM ELECTROLYTIC CAPACITORS

AK

Higher temperature range & Long Life
Series

■ Dimensions, Rated Ripple Current

Capacitance (μ F)	Rated Voltage(V)											
	10(13)			16(20)			25(32)			35(44)		
	Size	Ripple		Size	Ripple		Size	Ripple		Size	Ripple	
100							8x11	340		10x12.5	340	
220	8x11	340		8x11	340		10x12.5	500		10x16	500	
330	10x12.5	500		10x12.5	500		10x16	630		10x20	770	
470	10x16	630		10x20	770		10x20	770		13x20	920	
1000	10x20	770		13x20	920		13x25	1250		16x25	1380	
2200	13x25	1250		16x25	1380		16x32	1450				
3300	16x25	1380		16x32	1450							
4700	16x32	1450		18x32	1720							

Capacitance (μ F)	Rated Voltage(V)					
	50(63)			63(79)		
	Size	Ripple		Size	Ripple	
47	8x11	245		8x11	245	
100	10x12.5	415		10x15	455	
220	10x20	491		13x20	665	
330	13x20	665		13x25	995	
470	13x25	995		16x25	1000	
1000	16x32	1280				

☆ Size: D \times L (mm) ☆ Ripple Current: 125°C, 100KHz(mA/rms)

Capacitance (μ F)	Rated Voltage(V)											
	160(200)		200(250)		250(300)		350(400)		400(450)		450(500)	
	Size	Ripple	Size	Ripple	Size	Ripple	Size	Ripple	Size	Ripple	Size	Ripple
1.0							8x11	25	10x12.5	28	8x16	25
2.2					8x11	28	10x12.5	32	10x16	35	10x16	32
3.3	8x11	28	8x11	28	10x12.5	32	10x16	45	10x16	42	10x20	40
4.7	10x12.5	40	10x12.5	40	10x16	45	10 \times 20	53	10 \times 20	53	10 \times 25	58
10	10x16	60	10 \times 20	78	10 \times 20	78	10 \times 25	85	10 \times 25	86	13 \times 20	86
22	10 \times 20	115	10 \times 25	126	13 \times 20	128	13 \times 25	139	13 \times 30	142	16 \times 25	154
33	10 \times 25	154	13 \times 20	157	13 \times 25	171	16 \times 25	189	16 \times 25	189	16 \times 32	203
47	13 \times 20	187	13 \times 25	204	16 \times 25	225	16 \times 32	243	16 \times 32	243		
68	13 \times 25	245	16 \times 20	250	16 \times 32	292						
100	16 \times 25	329	16 \times 25	329								
150	16 \times 32	434										

☆ Size: D \times L (mm) ☆ Ripple Current: 125°C, 120Hz(mA/rms)

ALUMINUM ELECTROLYTIC CAPACITORS

SQ

For adapter and power supply applications
Series

- Features: 105°C 2000 hours ;Wide temperature range;High Ripple
- Recommended Applications :AV(TV, Video, Audio); Monitor/Computer;
OA/HA/Communication; Converter/Inverter;
Energy saving lamp; PFC circuit;
SMPS; Ballast; Adapter
- Corresponding product to RoHS

SQ
↑ High Ripple
SH



Specifications

Item	Characteristics							
Operating Temperature Range	-40~+105°C							
Rated Voltage Range(WV)	160 ~ 450VDC							
Rated Capacitance Range	2.2 ~ 220µF							
Capacitance Tolerance	± 20 % at 120Hz , 20°C							
Leakage Current (MAX) (20°C)	I ≤ 0.03CV + 10µA (After rated voltage applied for 3 minutes) I = Leakage Current (µA) C= Nominal Capacitance (µF) V= Rated Voltage (V)							
Dissipation Factor (MAX) (tanδ) (120Hz,20°C)	WV	160	200	250	350	400	450	
	tanδ	0.15	0.15	0.15	0.24	0.24	0.24	
Low Temperature Stability Impedance Ratio (MAX)	Z (120Hz)	160	200	250	350	400	450	
	Z(-25°C) / Z(20°C)	3	3	3	3	3	3	
	Z(-40°C) / Z(20°C)	6	6	6	6	6	6	
Endurance	After apply rated voltage with rated ripple current for 2000hrs at 105°C , the capacitors shall meet the following requirements.							
	Capacitance Change	Within ± 20 % of initial value						
	Dissipation Factor	Not more than 200% of the specified value						
Shelf Life	After leaving capacitors under no load at 105°C for 1000 hours, the capacitors shall meet the same requirement as Endurance.							

Diagram of Dimensions

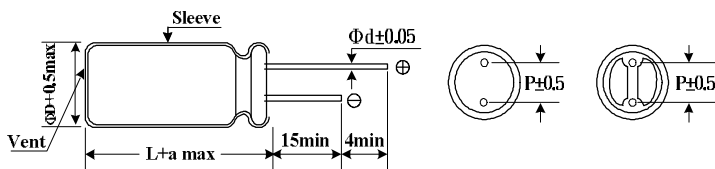

ψD	10	13	16	18
P	5	5	7.5	7.5
ψd	0.6	0.6	0.8	0.8
a	1.5	2	2	2

Multiplier for Ripple Current

Frequency coefficient

Frequency (Hz)		50	120	1K	10K	100K
Coefficient	< 33µF	0.80	1.00	1.36	1.54	1.80
	≥ 33µF	0.85	1.00	1.28	1.35	1.40

Frequency (Hz)		50	120	1K	10K	100K
Coefficient	< 33µF	0.45	0.55	0.75	0.85	1.00
	≥ 33µF	0.60	0.70	0.90	0.95	1.00

ALUMINUM ELECTROLYTIC CAPACITORS

SQ

For adapter and power supply applications
Series

■ Dimensions, Rated Ripple Current

Capacitance (μ F)	Rated (Surge) Voltage								
	160(200)			200(250)			250(300)		
	ψ DxL	Ripple		ψ DxL	Ripple		ψ DxL	Ripple	
		120Hz	100KHz		120Hz	100KHz		120Hz	100KHz
10							10x20	120	220
22	10x20	195	350	10x20	195	350	13x25	165	300
33	13x20	315	450	13x20	365	520	13x25	280	400
47	13x25	420	600	13x25	420	600	16x25	505	720
68	13x25	420	600	16x25	665	950	16x32	570	810
100	16x25	665	950	16x32	840	1200	18x36	735	1050
220	18x36	980	1400						

Capacitance (μ F)	Rated (Surge) Voltage								
	350(400)			400(450)			450(500)		
	ψ DxL	Ripple		ψ DxL	Ripple		ψ DxL	Ripple	
		120Hz	100KHz		120Hz	100KHz		120Hz	100KHz
2.2	10x16	30	50	10x16	80	140	10x16	60	110
3.3	10x16	35	60	10x20	110	195	10x20	75	135
4.7	10x20	45	78	10x25	120	220	13x20	105	190
10	13x20	75	130	10x16	135	243	13x25	140	250
				13x25	200	360			
22	16x25	115	205	13x20	240	432	13x20	180	324
				13x25	265	477	13x25	200	360
				16x25	315	570	16x32	265	480
33	16x32	180	255	16x32	490	700	16x25	350	500
							18x36	455	650
47	18x32	225	320	16x25	350	490	16x25	380	532
				18x32	600	860			
68				16x30	510	714	18x25	470	658
				16x32	550	770			
82						18x36	520	720	
100	18x45	370	530	18x32	680	952	18x40	620	860
120				18x32	750	1050	18x40	650	910
							18x45	720	1000
150				18x36	800	1120			

☆ Size: D ψ x L (mm) ☆ Ripple Current : mA/rms, 105°C

ALUMINUM ELECTROLYTIC CAPACITORS



High Ripple and long life Series



- Features: High temperature life time 5000 hours at 105°C
- Recommended Applications : High ripple current for Electronic Ballast , Power Supply...etc
- Corresponding product to RoHS

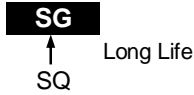

Specifications

Item	Characteristics							
Operating Temperature Range	-40~+105°C		-25~+105°C			-25~+105°C		
Rated Voltage Range	160 ~ 400VDC		450VDC			500VDC		
Rated Capacitance Range	4.7 ~ 330µF		3.3 ~ 100µF			4.7~ 150µF		
Capacitance Tolerance	± 20 % at 120Hz , 20°C							
Leakage Current (MAX) (20°C)	I=0.06CV + 10(µA) (After rated voltage applied for 2 minutes)				I=0.04CV + 100(µA)			
Dissipation Factor (MAX) (tanδ) (120Hz ,20°C)	WV	160	200	250	350	400	450	500
	tanδ	0.15	0.15	0.15	0.20	0.24	0.24	0.24
Low Temperature Stability Impedance Ratio (MAX)	Z (120Hz)	160	200	250	350	400	450	500
	Z-25°C / Z+20°C	3	3	3	5	5	6	6
	Z-40°C / Z+20°C	6	6	6	6	6	—	—
Endurance	After applying rated voltage with rated ripple current for 5000 hours at 105°C , the capacitors shall meet the following requirements.							
	Capacitance Change	Within ± 20 % of initial value						
	Dissipation Factor	Not more than 200% of the specified value						
	Leakage Current	initial specified value or less						
Shelf Life	After placed at 105°C without voltage applied for 1000 hours, the capacitors shall meet the same requirement as Endurance.							

Diagram of Dimensions

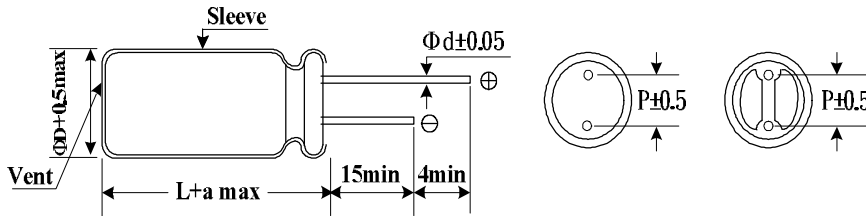

ψD	10	13	16	18	22
P	5.0	5.0	7.5	7.5	10.0
ψd	0.6	0.6	0.8	0.8	0.8
a	1.5	2.0	2.0	2.0	2.0

Multiplier for Ripple Current

Frequency coefficient

Frequency (Hz)	50,60	120	300	1K	10K~100K
160~450V	0.80	1.00	1.20	1.40	1.60
500V	0.75	1.00	1.20	1.35	1.50

ALUMINUM ELECTROLYTIC CAPACITORS



High Ripple and long life Series

■ Dimensions, Rated Ripple Current

Capacitance (μF)	Rated (Surge) Voltage					
	160 (200)		200 (250)		250 (300)	
	Size	Ripple	Size	Ripple	Size	Ripple
10			※10x16	80	※10x16	85
					10X20	100
15			※10x16	100		
22	10X20	160	10X20	160	※10x25	145
					13x20	160
33	10X20	210	※10X20	160	13x20	210
			13x20	210		
47	13x20	260	13x20	260	13x25	270
					16x20	275
68	13x25	360	13x25	360	16x25	380
	16x20	430	16x20	430	18x20	375
100	16x25	475	16x25	475	16x32	520
	18x20	465	18x20	465	18x25	500
150	16x32	650	18x25	650	18x32	650
	18x25	625				
220	16x32	750	18x32	780	18x40	820
	18x25	725				
330	18x32	960				

Capacitance (μF)	Rated (Surge) Voltage					
	350 (400)		400 (450)		450 (500)	
	Size	Ripple	Size	Ripple	Size	Ripple
3.3					10X20	60
4.7			※10x16	60	13x20	80
6.8			※10x16	72	※10X20	90
10	10X20	100	※10x16	85	13x20	110
			10X20	100	13x25	110
22	13x20	160	13x20	145	13x20	145
			13x25	170	16x25	190
			16x20	200	18x20	200
33	13x25	230	16x25	230	16x25	235
	16x20	250	18x20	250	16x32	275
					18x25	280
47	16x25	300	16x25	255	16x26	270
	18x20	315	16x32	300	18x32	340
			18x25	325		
68	16x32	400	16x30	340	18x25	335
	18x25	380	16x32	350	18x32	395
			18x36	420	18x40	460
100	18x32	530	18x32	465	22x40	580
			18x40	545		
150			18x40	525		
			22x40	650		

☆ Size : D \times L (mm) ☆ Ripple Current : mA/rms. 105°C, 120Hz

※ Down Size : 3000 Hrs

ALUMINUM ELECTROLYTIC CAPACITORS

SG

High Ripple and long life
Series

■ Dimensions, Rated Ripple Current

Capacitance (μ F)	Rated (Surge) Voltage	
	500 (550)	
	Size	Ripple
4.7	10X20	70
6.8	13X20	100
10	12.5X25	130
22	16X25	225
	18X20	220
33	16X32	305
	18X25	295
47	16x36	430
	18x32	435
68	18x32	530
	18x36	555
82	18x40	640
	22x35	675
100	22x35	745
120	22x40	865
150	22x45	1020

☆ Size : D ψ x L (mm) ☆ Ripple Current : mA/rms. 105°C,120Hz
 ※ Down Size : 3000 Hrs

ALUMINUM ELECTROLYTIC CAPACITORS

SP

Miniature and long life
Series



- Features: High temperature and long life at 105°C for 8000 to 10000 hours
- Recommended Applications: Applicable for Electronic Ballast
- Corresponding product to RoHS

SP



SG

Long Life

Specifications

Item	Characteristics				
Operating Temperature Range	-40~+105°C		-25~+105°C		
Rated Voltage Range	160 ~ 400VDC		450VDC		
Rated Capacitance Range	3.3 ~ 330µF				
Capacitance Tolerance	± 20 % at 120Hz , 20°C				
Leakage Current(MAX)(20°C)	$I=0.04CV + 100(\mu A)$,(After rated voltage applied for 2 minutes)				
Dissipation Factor (MAX) (tanδ) (120Hz ,20°C)	WV	160	200	400	450
	tanδ	0.20	0.20	0.24	0.24
Low Temperature Stability Impedance Ratio (MAX)	Z(120Hz)	160	200	400	450
	Z-25°C / Z+20°C	3	3	5	6
	Z-40°C / Z+20°C	6	6	6	—
Endurance	The following specifications shall be satisfied when the capacitors are restored to 20°C after subjected to DC voltage with the max ripple current is applies for 10000 hours (8000 hours for ψ10) at 105°C.				
	Capacitance Change	Within ± 20 % of initial value			
	Dissipation Factor	Not more than 200% of the specified value			
	Leakage Current	initial specified value or less			
Shelf Life	After placed at 105°C without voltage applied for 1000 hours, the capacitors shall meet the same requirement as Endurance.				

Diagram of Dimensions

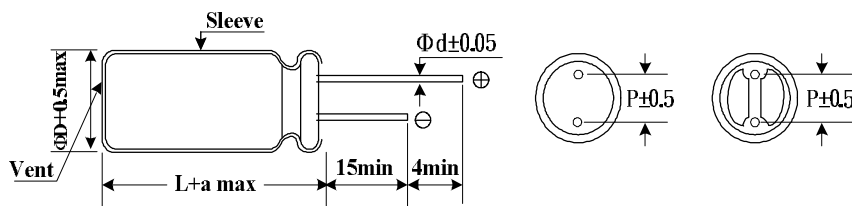

ψD	10	12.5	13	16	18
P	5.0	5.0	7.5	7.5	7.5
ψd	0.6	0.6	0.8	0.8	0.8
a	1.5	2.0	2.0	2.0	2.0

Multiplier for Ripple Current

Frequency coefficient

Frequency (Hz)	120	1K	10K	100K
Coefficient	1.0	1.6	1.8	2.0

ALUMINUM ELECTROLYTIC CAPACITORS

SP

**Miniature and long life
Series**

■ Dimensions, Rated Ripple Current

Capacitance (μF)	Rated (Surge) Voltage					
	160 (200)			200 (250)		
	Size	Ripple		Size	Ripple	
120Hz		100KHz	120Hz		100KHz	
22				10x20	220	440
33	10x20	250	500	10x20	260	520
				12.5x20	290	580
47	10x20	290	580	13x20	330	660
	12.5x20	330	660			
68	13x25	360	720	13x25	360	720
	16x20	380	760	16x20	380	760
100	13x25	485	970	16x25	560	1120
	16x20	560	1120			
	16x25	560	1120			
	18x20	560	1120			
150	16x25	600	1200	16x32	640	1280
	16x32	650	1300			
	18x25	650	1300			
220	16x32	650	1300			
	18x25	650	1300			
330	18x36	690	1380			

Capacitance (μF)	Rated (Surge) Voltage					
	400 (450)			450 (500)		
	Size	Ripple		Size	Ripple	
120Hz		100KHz	120Hz		100KHz	
3.3				10x16	50	100
4.7				10x20	70	140
6.8	10x20	75	150	10x20	75	150
				12.5x20	90	180
10	10x20	90	180	12.5x20	155	310
22	16x20	150	300	16x25	280	560
				18x20	275	550
33	16x25	260	520	16x32	310	620
				18x25	295	590
47	16x32	350	700	16x36	440	880
				18x32	440	880
68	18x32	435	870			

☆ Size : Dφx L (mm) ☆ Ripple Current: (mA/rms), 105°C

ALUMINUM ELECTROLYTIC CAPACITORS

SU Long Life Series

■ 105°C 10000~12000hrs long Life

■ Recommended Applications: Electronic lighting and power

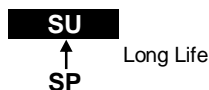

■ Specifications

Item	Characteristics							
Category Temperature Range	-25 ~ +105°C							
Rated Voltage Range	160~450VDC							
Rated Capacitance Range	3.3 ~ 330μF							
Capacitance Tolerance	± 20 % at 120Hz , 20°C							
Leakage Current (MAX) (20°C)	I=0.04CV +100μA . (After rated voltage applied for 2 minutes) I= Leakage Current (μA) C= Nominal Capacitance (μF) V= Rated Voltage (V) (20°C)							
Dissipation Factor (MAX) (tanδ) (120Hz ,20°C)	WV	160	200	250	350	400	450	
	tanδ	0.15	0.15	0.15	0.20	0.20	0.20	
Low Temperature Stability Impedance Ratio (MAX)	Z(120Hz)	160	200	250	350	400	450	
	Z-25°C / Z+20°C	3	3	3	5	5	6	
Endurance	After applying rated voltage with rated ripple current for 10000~12000hours at 105°C , the capacitors shall meet the following requirements.							
	Capacitance Change	Within ± 20 % of initial value					ΦD×L	Life Time(hrs)
	Dissipation Factor	200% or less of initial specified value					10Φ	10000
	Leakage Current	initial specified value or less					≥ 13Φ	12000
Shelf Life	After placed at 105°C without voltage applied for 1000 hours, the capacitors shall meet the same requirement as load life.							

■ Diagram of Dimensions

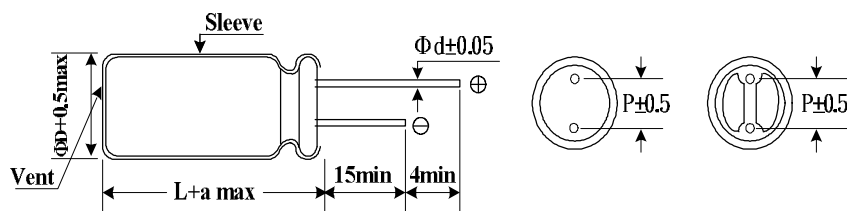

ψD	10.0	13.0	16.0	18.0
P	5.0	5.0	7.5	7.5
ψd	0.6	0.6	0.8	0.8
a	1.5	2.0	2.0	2.0

■ Multiplier for Ripple Current

Frequency coefficient

Frequency (Hz)	120	1K	10K	100K
Coefficient	0.5	0.8	0.9	1.0

ALUMINUM ELECTROLYTIC CAPACITORS

SU Long Life Series

■ Dimensions, Rated Ripple Current

Capacitance (μF)	Rated Voltage(V)					
	160		200		250	
	Size	Ripple	Size	Ripple	Size	Ripple
10					10×16	320
22			10×16	500	10×20	500
33	10×16	500	10×20	520	13×20	800
47	10×20	580	13×20	660	13×20	980
68	13×20	720	13×25	720		
100	13×25	970	16×25	1120	16×25	1530
150	16×25	1120	16×32	1620	18×25	1940
220	16×32	1300	18×32	2080	18×36	2753
330	18×36	1380			18×50	3912
390			18×50	3380		
470						
560	18×50	2086				

Capacitance (μF)	Rated Voltage(V)					
	350		400		450	
	Size	Ripple	Size	Ripple	Size	Ripple
6.8	10×16	280	10×16	140		
10	10×20	350	10×20	180	10×20	180
15					13×20	380
22	13×20	650	13×20	430	13×25	500
33	13×25	900	16×25	520	16×25	560
47	16×25	1000	16×32	700	16×36	880
68	16×32	1100	18×32	870	16×36	1110
100			18×50	1290	18×50	1560

☆ Size: Dψx L (mm) ☆ Ripple Current: 105°C, 100KHz(mA/rms)

ALUMINUM ELECTROLYTIC CAPACITORS

TE Ultra Long Life Series



■ 105°C 12000~20000hrs Ultra long Life

■ Recommended Applications: For LED Lightingr

Specifications

Item	Characteristics												
Category Temperature Range	-40 ~ +105°C												
Rated Voltage Range	160~400VDC												
Rated Capacitance Range	1.0 ~ 33µF												
Capacitance Tolerance	± 20 % at 120Hz , 20°C												
Leakage Current (MAX) (20°C)	CV ≤ 1000		CV > 1000		I= Leakage Current (µA) C= Nominal Capacitance (µF) V= Rated Voltage (V) (20°C)								
	I=0.1CV +40µA (1 minutes)		I=0.04CV +100µA (1 minutes)										
	I=0.03CV +15µA (5 minutes)		I=0.02CV +25µA (5 minutes)										
Dissipation Factor (MAX) (tanδ) (120Hz ,20°C)	WV	160	200	400									
	tanδ	0.24	0.24	0.24									
Low Temperature Stability Impedance Ratio (MAX)	WV		160	200	400								
	Z(120Hz)												
	Z-25°C / Z+20°C	3	3	6									
Z-40°C / Z+20°C	8	8	10										
Endurance	After applying rated voltage with rated ripple current for 12000~20000hours at 105°C, the capacitors shall meet the following requirements.												
	Capacitance Change	Within ± 30 % of initial value			<table border="1" style="float: right;"> <thead> <tr> <th>ΦD×L</th> <th>Life Time(hrs)</th> </tr> </thead> <tbody> <tr> <td>6.3x11,8x9,10x9</td> <td>12000</td> </tr> <tr> <td>8x11,10x12.5</td> <td>15000</td> </tr> <tr> <td>10x16</td> <td>20000</td> </tr> </tbody> </table>	ΦD×L	Life Time(hrs)	6.3x11,8x9,10x9	12000	8x11,10x12.5	15000	10x16	20000
	ΦD×L	Life Time(hrs)											
	6.3x11,8x9,10x9	12000											
8x11,10x12.5	15000												
10x16	20000												
Dissipation Factor	300% or less of initial specified value												
Leakage Current	initial specified value or less												
Shelf Life	After placed at 105°C without voltage applied for 1000 hours, the capacitors shall meet the same requirement as load life.												

Diagram of Dimensions

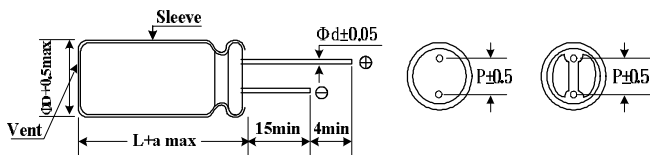

ψD	6.3	8.0	10.0
P	2.5	3.5	5.0
ψd	0.5	0.6	0.6
a	2.0	2.0	2.0

Multiplier for Ripple Current

Frequency coefficient

Frequency (Hz)		120	1K	10K	100K
Coefficient	1~5.6µF	1.0	1.6	1.8	2.0
	6.8~18µF	1.0	1.5	1.7	1.9
	22~33µF	1.0	1.4	1.6	1.8

ALUMINUM ELECTROLYTIC CAPACITORS

TE Ultra Long Life
Series

■ Dimensions, Rated Ripple Current

Capacitance (μF)	Rated Voltage(V)					
	160		200		400	
	Size	Ripple	Size	Ripple	Size	Ripple
1.0					6.3x11	24
1.2					8x9	28
1.5					8x9	30
1.8					8x9	33
2.2			6.3x11	36	8x9	36
					8x11	40
2.7					8x11	43
3.3			6.3x11	42	8x11	47
					10x9	48
3.9					10x12.5	57
4.7			6.3x11	49	10x12.5	61
5.6	6.3x11	52	8x9	56		
6.8			8x9	62	10x16	85
8.2			8x9	66		
10	8x9	70	8x11	80		
12			10x9	88		
15	8x11	92				
	10x9	95				
18			10x12.5	113		
22	10x12.5	121				
27			10x16	149		
33	10x16	158				

☆ Size: D \times L (mm) ☆ Ripple Current: 105°C, 120Hz(mA/rms)

ALUMINUM ELECTROLYTIC CAPACITORS

TH Miniature and general purpose Series



- Features: 105°C 2000 hours
- Recommended Applications: For high quality , reliability application, high CV product
- Suitable for slim application
- Corresponding product to RoHS

Specifications

Item	Characteristics		
Operating Temperature Range	-25~+105°C		
Rated Voltage Range	250 ~ 450VDC		
Rated Capacitance Range	10 ~ 150μF		
Capacitance Tolerance	± 20 % at 120Hz , 20°C		
Leakage Current (MAX)(20°C)	I=0.03CV+10(μA) ,After rated voltage applied for 2 minutes		
Dissipation Factor (MAX) (tanδ) (120Hz ,20°C)	WV	250	350~450
	tanδ	0.15	0.20
Low Temperature Stability Impedance Ratio (MAX)	Z(120Hz)	250	350~450
	Z-25°C / Z+20°C	4	6
Endurance	After applying rated voltage for 2000 hours at 105°C the capacitors shall meet the following requirements.		
	Capacitance Change	Within ± 20 % of initial value	
	Dissipation Factor	Not more than 200% of the specified value	
Shelf Life	After leaving capacitors under no load at 105°C for 1000 hours. the capacitors shall meet the same requirement as Endurance.		
	Leakage Current	initial specified value or less	

Diagram of Dimensions

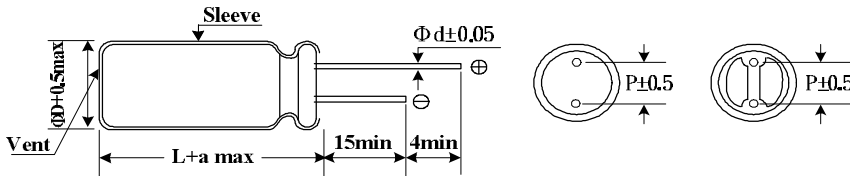

ψD	8	10.0	12.5
p	3.5	5.0	5.0
ψd	0.6	0.6	0.6
a	2.0	2.0	2.5

Multiplier for Ripple Current

Frequency coefficient

Frequency (Hz)	120	300	1K	10K
160 ~ 450V ALL Cap (μF)	1.00	1.25	1.40	1.60

ALUMINUM ELECTROLYTIC CAPACITORS

TH Miniature and general purpose
Series

■ Dimensions, Rated Ripple Current

Capacitance (μ F)	Rated (Surge) Voltage									
	250 (300)		350 (400)		400 (450)		420(470)		450 (500)	
	Size	Ripple	Size	Ripple	Size	Ripple	Size	Ripple	Size	Ripple
10										
12									8x30	115
15			8x30	140	8x35	170	8x35	150	8x35	135
22	8x30	200	8x35	180	8x40	220	8x40	195	8x42	190
									10x30	190
27	8x35	215	8x40	210	8x45	250	8x45	220	8x45	210
					10x35	250	10x35	220	10x35	210
33	8x35	240	8x42	240	8x50	295	8x50	285	8x52	290
					10x40	295	10x40	285	10x42	290
39	8x40	260	10x40	280	8x52	320	10x42	310	10x45	320
	10x30	275			10x40	320	12.5x35	320	12.5x40	330
47	8x45	310	10x45	325	10x45	355	10x45	350	10x50	360
					12.5x40	365	12.5x40	350	12.5x42	370
56	10x40	350	10x50	380	10x50	405	10x52	390	12.5x45	415
					12.5x40	405	12.5x42	390		
68	10x40	400	12.5x40	430	10x55	460	12.5x45	450	12.5*50	475
					12.5x45	460				
82	10x45	450	12.5x45	500	12.5x50	525	12.5x52	535	12.5x55	535
100	10x50	525	12.5x50	630	12.5x55	620				
150	12.5x45	725								

☆ Size: D \times L (mm) ☆ Ripple Current: (mA/rms). 105°C, 120Hz

ALUMINUM ELECTROLYTIC CAPACITORS

TG

High Ripple and long life Series

- Features: High temperature life time 5000 hours at 105°C
- Recommended Applications : High ripple current for Electronic Ballast , Power Supply...etc
- Suitable for slim application
- Corresponding product to RoHS



■ Specifications

Item	Characteristics				
Operating Temperature Range	-25~+105°C				
Rated Voltage Range	250 ~ 450VDC				
Rated Capacitance Range	10 ~ 150μF				
Capacitance Tolerance	± 20 % at 120Hz , 20°C				
Leakage Current (MAX) (20°C)	I=0.06CV + 10(μA) , (After rated voltage applied for 2 minutes)				
Dissipation Factor (MAX) (tanδ) (120Hz ,20°C)	WV	250	350	400	420 · 450
	tanδ	0.15	0.20	0.24	0.24
Low Temperature Stability Impedance Ratio (MAX)	Z (120Hz)	250	350	400	420 · 450
	Z-25°C / Z+20°C	3	5	5	6
Endurance	After applying rated voltage with rated ripple current for 5000 hours at 105°C , the capacitors shall meet the following requirements.				
	Capacitance Change	Within ± 20 % of initial value			
	Dissipation Factor	Not more than 200% of the specified value			
Shelf Life	After placed at 105°C without voltage applied for 1000 hours, the capacitors shall meet the same requirement as Endurance.				
	Leakage Current	initial specified value or less			

■ Diagram of Dimensions

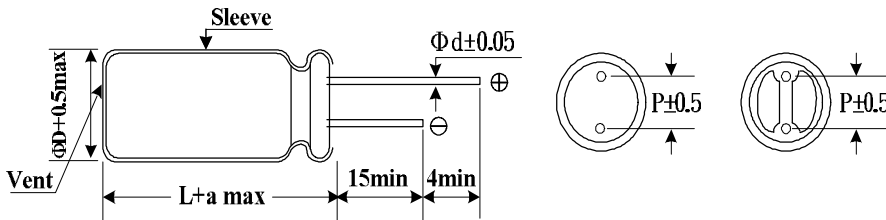

ψD	8	10	12.5
P	3.5	5.0	5.0
ψd	0.6	0.6	0.6
a	2.0	2.0	2.5

■ Multiplier for Ripple Current

Frequency coefficient

Frequency (Hz)	50,60	120	300	1K	10K~100K
Coefficient	0.80	1.00	1.20	1.40	1.60

ALUMINUM ELECTROLYTIC CAPACITORS

TG

**High Ripple and long life
Series**

■ Dimensions, Rated Ripple Current

Capacitance (μF)	Rated (Surge) Voltage									
	250 (300)		350 (400)		400 (450)		420 (470)		450(500)	
	Size	Ripple	Size	Ripple	Size	Ripple	Size	Ripple	Size	Ripple
10										
12									8x35	110
15			8x35	120	8x35	110	8x35	105	8x40	130
22	8x30	130	8x40	150	8x40	140	8x40	135	8x45	165
									10x35	165
27	8x32	150	8x45	170	8x45	165	8x45	155	8x52	195
					10x35	165	10x35	155	10x40	195
33	8x35	170	8x50	200	8x50	190	8x50	185	10x45	230
					10x40	190	10x40	185	12.5x35	230
39	8x42	200	10x45	235	10x45	220	10x45	215	10x50	265
							12.5x35	215	12.5x40	265
47	8x45	220	10x50	270	10x50	255	10x50	245	10x52	295
					12.5x40	255	12.5x40	245	12.5x45	310
56	10x42	300	12.5x40	300	12.5x45	300	12.5x45	290	12.5x50	355
68	10x45	330	12.5x45	350	12.5x50	350	12.5x50	335	12.5x55	410
82	10x50	390	12.5x50	400	12.5x55	400	12.5x55	385		
100	12.5x42	440	12.5x55	460						
120	12.5x45	490								
150	12.5x50	560								

☆ Size : D \times L (mm) ☆ Ripple Current : mA/rms. 105°C, 120Hz

ALUMINUM ELECTROLYTIC CAPACITORS

TP Miniature and long life Series



- Features: High temperature and long life at 105°C for 8000 to 10000 hours
- Recommended Applications: Applicable for Electronic Ballast
- Suitable for slim application
- Corresponding product to RoHS

Specifications

Item	Characteristics					
Operating Temperature Range	-40~+105°C			-25~+105°C		
Rated Voltage Range	160 ~ 400VDC			450VDC		
Rated Capacitance Range	10 ~ 330µF					
Capacitance Tolerance	± 20 % at 120Hz , 20°C					
Leakage Current(MAX)(20°C)	I=0.04CV + 100(µA) ,(After rated voltage applied for 2 minutes)					
Dissipation Factor (MAX) (tanδ) (120Hz ,20°C)	WV	160	200	250	400	420 · 450
	tanδ	0.20	0.20	20	0.24	0.24
Low Temperature Stability Impedance Ratio (MAX)	Z(120Hz)	160	200	250	400	420 · 450
	Z-25°C / Z+20°C	3	3	3	5	6
	Z-40°C / Z+20°C	6	6	6	6	—
Endurance	The following specifications shall be satisfied when the capacitors are restored to 20°C after subjected to DC voltage with the max ripple current is applies for 10000 hours (8000 hours for ψ10) at 105°C .					
	Capacitance Change	Within ± 20 % of initial value				
	Dissipation Factor	Not more than 200% of the specified value				
Shelf Life	After placed at 105°C without voltage applied for 1000 hours, the capacitors shall meet the same requirement as Endurance.					

Diagram of Dimensions

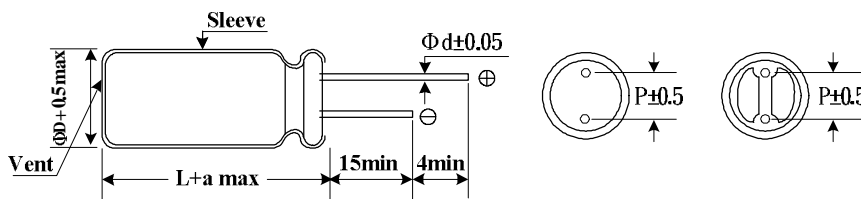

ψD	10	12.5
P	5.0	5.0
ψd	0.6	0.6
a	2.0	2.5

Multiplier for Ripple Current

Frequency coefficient

Frequency (Hz)	120	1K	10K	100K
Coefficient	1.0	1.6	1.8	2.0

ALUMINUM ELECTROLYTIC CAPACITORS

TP

**Miniature and long life
Series**

■ Dimensions, Rated Ripple Current

Capacitance (μF)	Rated (Surge) Voltage											
	160 (200)		200 (250)		250(300)		400(450)		420(470)		450(500)	
	Size	Ripple	Size	Ripple	Size	Ripple	Size	Ripple	Size	Ripple	Size	Ripple
10												
22											10×40	250
27									10×40	200	10×42	270
33									10X45	235	10*45	300
39							10×45	260	10X50	270	10×50	340
											12.5*40	350
47							12.5x40	310	12.5×42	310	12.5×45	420
56							10×52	340	12.5×45	330	12.5×50	480
							12.5x45	360				
68							12.5×50	400	12.5x50	390	12.5×55	530
82					10x52	390	12.5×55	460	12.5X55	450		
100			10x45	330	12.5x42	470						
120			10×50	430	12.5x45	480						
150	10×45	410	12.5x45	510	12.5×50	540						
180	10×50	470	12.5x50	590	12.5×55	650						
220	12.5x45	550	12.5×52	650								
270	12.5×50	640	12.5×55	750								
330	12.5×55	740										

☆ Size : Dφx L (mm) ☆ Ripple Current: (mA/rms), 105°C , 120Hz

ALUMINUM ELECTROLYTIC CAPACITORS

LH

General Purpose Series

- Endurance : 85°C 2000 hours
- Ideally suitable for using in Switching Power Supplies and other industrial /commercial applications
- Corresponding product to RoHS



Specifications

Item	Characteristics
Operating Temperature Range	-40~+85°C -25~+85°C
Rated Voltage Range	6.3 ~ 100VDC 160 ~ 500VDC
Capacitance Range	820 ~ 120000μF 47 ~ 2200μF
Capacitance Tolerance	± 20 % at 120Hz , 20°C
Leakage Current (MAX)	I=0.02CV or 3(mA) , whichever is smaller. (After 5 minutes application of rated voltage at 20°C)
Dissipation Factor (MAX) (tanδ) (120Hz ,20°C)	Rated voltage(V) 6.3 10 16 25 35 50 63~100 160~400 420~500
	tanδ 0.60 0.55 0.55 0.45 0.35 0.30 0.25 0.15 0.20
Low Temperature Stability Impedance Ratio (MAX)	Measurement frequency : 120Hz
	Rated voltage(V) 6.3~16 25 35 50~63 80~100 160~400 420~500
	Z-25°C / Z+20°C 3 3 3 2 2 4 8
	Z-40°C / Z+20°C 12 10 8 6 5
Endurance	After applying rated voltage with rated Ripple current for 2000hrs at 85°C , the capacitor shall meet the following requirements.
	Capacitance Change Within ± 20 % of initial value
	Dissipation Factor Not more than 200% of the specified
	Leakage Current initial specified value or less
Shelf Life	After placed at 85°C without voltage applied for 1000 hours, the capacitor shall meet the same requirement as Endurance.

Diagram of Dimensions

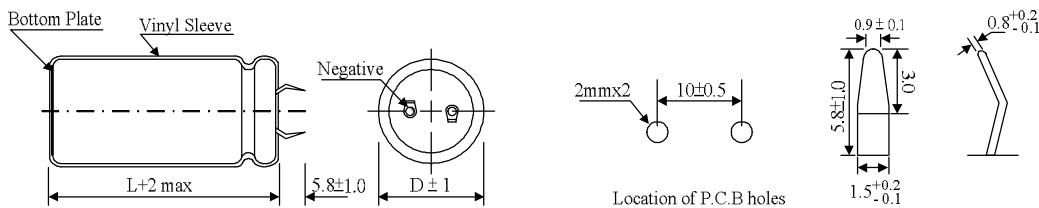

Multiplier for Ripple Current

Frequency coefficient

Frequency (Hz)	50	60	120	1K	10K
6.3~100V	0.88	0.90	1.00	1.15	1.16
160~250V	0.75	0.78	1.00	1.30	1.50
350~450V	0.74	0.76	1.00	1.35	1.45
500V	0.72	0.74	1.00	1.20	1.30

ALUMINUM ELECTROLYTIC CAPACITORS



General Purpose Series

■ Dimensions, Rated Ripple Current

Capacitance (μF)	Rated (Surge) Voltage							
	6.3 (8)		10 (13)		16 (20)		25 (32)	
	Size	Ripple	Size	Ripple	Size	Ripple	Size	Ripple
5600							22x25	2.20
6800							22x30	2.40
							25x25	2.45
8200					22x25	2.60	22x35	2.70
							25x25	2.75
10000					22x30	2.70	22x40	3.10
					25x25	2.75	25x30	3.15
							30x25	3.20
12000			22x25	2.40	22x30	2.90	22x45	3.50
					25x25	2.95	25x35	3.45
							30x30	3.50
							35x25	3.55
15000	22x25	2.44	22x30	2.75	22x35	3.30	22x50	4.00
			25x25	2.75	25x30	3.45	25x40	3.95
					30x25	3.50	30x35	4.00
							35x30	4.05
18000	22x30	2.60	22x35	3.15	22x40	3.70	25x45	4.45
	25x25	2.62	25x25	3.05	25x35	3.75	30x35	4.45
					30x30	3.80	35x30	4.60
22000	22x30	3.06	22x40	3.55	22x50	4.35	30x40	5.20
	25x25	3.07	25x30	3.50	25x40	4.30	35x35	5.15
			30x25	3.55	30x30	4.25	30x45	5.95
					35x25	4.20	35x40	5.90
27000	22x35	3.49	22x45	4.05	25x45	4.70		
	25x30	3.52	25x35	4.00	30x35	4.65	30x50	6.70
	30x25	3.57	30x30	4.05	35x30	4.65	35x45	6.75
33000	22x40	3.97	22x50	4.60	30x40	5.35		
	25x35	4.02	25x40	4.55	35x30	5.40		
	30x30	4.05	30x30	4.50			35x50	7.55
	35x25	4.10	35x25	4.50				
39000	22x50	4.56	25x45	5.10	30x45	6.00	35x45	7.56
	25x40	4.50	30x35	5.05	35x35	5.95		
	30x30	4.46	35x30	5.05				
	35x25	4.51						
47000	25x45	5.09	25x50	5.75	30x50	6.80	35x50	8.30
	30x35	5.06	30x40	5.70	35x40	6.75		
	35x30	5.03	35x30	5.65				
56000	25x50	5.71	30x45	6.45	35x45	7.60		
	30x40	5.70	35x35	6.40				
	35x30	5.75						
68000	30x45	6.48	30x50	7.05	35x50	8.00		
	35x35	6.42	35x40	7.10				
82000	30x50	7.32	35x50	7.50	35x60	8.50		
	35x40	7.29						
100000	35x45	8.31						
120000	35x50	8.60						

☆ Size: D \times L (mm) ☆ Ripple Current : A/rms. 85°C, 120Hz

ALUMINUM ELECTROLYTIC CAPACITORS



General Purpose Series

■ Dimensions, Rated Ripple Current

Capacitance (μF)	Rated (Surge) Voltage							
	35 (44)		50 (63)		63 (79)		80 (100)	
	Size	Ripple	Size	Ripple	Size	Ripple	Size	Ripple
1200							22x25	1.65
1500							22x30	1.90
							25x25	1.90
1800					22x25	1.85	22x35	2.20
							25x30	2.20
							30x25	2.20
2200			22x25	1.90	22x30	2.30	22x40	2.45
					25x25	2.30	25x30	2.45
							30x25	2.50
2700			22x30	2.10	22x35	2.45	22x45	2.80
			25x25	2.20	25x30	2.45	25x35	2.80
					30x25	2.50	30x30	2.85
3300							35x25	2.85
			22x30	2.35	22x40	2.60	22x50	3.15
			25x25	2.35	25x30	2.65	25x40	3.20
					30x25	2.70	30x30	3.20
3900							35x25	3.20
	22x25	2.20	22x35	2.65	22x45	2.95	25x45	3.60
			25x30	2.65	25x35	2.95	30x35	3.60
			30x25	2.65	30x30	3.00	35x30	3.60
4700	22x30	2.40	22x40	3.00	22x50	3.40	25x50	4.05
	25x25	2.40	25x35	3.00	25x40	3.35	30x40	4.05
			30x25	2.95	30x30	3.35	35x35	4.10
					35x25	3.40		
5600	22x35	2.75	22x45	3.35	25x45	3.70	30x45	4.55
	25x25	2.75	25x40	3.35	30x35	3.75	35x35	4.50
			30x30	3.35	35x30	3.75		
			35x25	3.40				
6800	22x40	2.85	22x50	3.80	30x40	4.25	30x50	5.15
	25x30	2.85	25x40	3.80	35x30	4.20	35x40	5.15
	30x25	2.90	30x30	3.80				
			30x35	3.85				
			35x30	3.85				
8200	22x45	3.15	25x50	4.35	30x45	4.80	35x45	5.85
	25x35	3.10	30x40	4.35	35x35	4.80		
	30x30	3.15	35x30	4.40				
10000	22x50	3.55	30x45	5.00	30x50	5.50	35x50	6.60
	25x40	3.50	35x35	4.95	35x40	5.45		
	30x30	3.45						
	35x25	3.40						
12000	25x45	3.95	30x50	5.60	35x45	6.20		
	30x35	4.00	35x40	5.55				
	35x30	4.05						
15000								
	25x50	4.95	35x45	6.45				
	30x40	4.95						
18000	35x35	5.00						
	30x45	5.50	35x50	6.70				
22000	35x40	5.55						
	30x50	6.00						
27000	35x45	6.05						
	35x50	6.90						

☆ Size: D \times L (mm) ☆ Ripple Current : A/rms. 85°C, 120Hz

ALUMINUM ELECTROLYTIC CAPACITORS

LH

**General Purpose
Series**

■ Dimensions, Rated Ripple Current

Capacitance (μ F)	Rated (Surge) Voltage							
	100 (125)		160 (200)		180 (225)		200 (250)	
	Size	Ripple	Size	Ripple	Size	Ripple	Size	Ripple
180					22x20	1.00	22x25	0.95
220					22x25	1.10	22x25	1.10
270			22x25	1.15	22x25	1.25	22x25	1.25
					25x20	1.25	22x30	1.25
330			22x25	1.40	22x25	1.40	22x25	1.45
			25x20	1.35	22x30	1.40	22x30	1.45
					25x25	1.40	25x25	1.45
390			22x30	1.55	22x30	1.60	22x30	1.60
			25x25	1.55	25x25	1.60	25x25	1.55
			30x25	1.50				
470			22x30	1.75	22x35	1.80	22x35	1.80
			25x25	1.75	25x30	1.80	25x30	1.80
			30x25	1.70	30x25	1.80	30x25	1.80
560			22x30	1.95	22x35	2.00	22x40	2.00
			25x30	1.95	22x40	2.00	25x35	2.00
			30x25	1.90	25x30	1.95	30x25	2.00
680					30x25	2.00		
			22x40	2.20	22x45	2.25	22x45	2.35
			25x30	2.20	25x35	2.20	25x35	2.30
			30x25	2.15	30x30	2.20	30x30	2.30
820					35x25	2.20	35x25	2.30
	22x25	1.85	22x45	2.50	22x50	2.55	25x40	2.60
			25x35	2.55	25x40	2.55	25x45	2.60
			30x30	2.50	30x30	2.60	30x30	2.60
			35x25	2.50	30x35	2.60	30x35	2.60
1000					35x25	2.60	35x30	2.60
	22x30	2.10	22x50	2.85	25x45	2.85	25x45	3.00
	25x25	2.10	25x40	2.80	30x35	2.85	25x50	3.00
			30x35	2.80	35x30	2.90	30x35	3.05
			35x25	2.80			30x40	3.05
1200							35x30	3.00
	22x35	2.40	25x45	3.15	30x40	3.25	25x50	3.30
	25x30	2.45	30x35	3.15	35x30	3.30	30x40	3.30
			35x30	3.20	35x35	3.30	30x45	3.30
							35x30	3.30
1500							35x35	3.30
	22x40	2.70	30x45	3.75	30x45	3.85	30x45	3.80
	25x30	2.75	35x30	3.70	35x35	3.80	30x50	3.80
	30x25	2.75	35x35	3.70	35x40	3.80	35x35	3.80
1800							35x40	3.80
	22x45	3.10	30x50	4.20	35x40	4.30	35x40	4.35
	25x35	3.15	35x40	4.20	35x45	4.30	35x45	4.35
	30x30	3.15						
2200								
2700								
3300								
3900								
4700								
5600								

☆ Size: D \times L (mm) ☆ Ripple Current : A/rms. 85°C, 120Hz

ALUMINUM ELECTROLYTIC CAPACITORS



General Purpose Series

■ Dimensions, Rated Ripple Cu

Capacitance (μ F)	Rated (Surge) Voltage											
	250 (300)		350 (400)		400 (450)		420 (470)		450 (500)		500(550)	
	Size	Ripple	Size	Ripple	Size	Ripple	Size	Ripple	Size	Ripple	Size	Ripple
47									22x25	0.50	25x20	0.50
56					22x20	0.55			22x25	0.65		
68			22x20	0.55	22x25	0.60			22x25	0.67		
					25x20	0.60			22x30	0.70		
82			22x25	0.65	22x25	0.80			22x30	0.80		
			25x20	0.65	25x20	0.80			25x25	0.80		
100			22x30	0.90	22x25	0.85			22x30	0.85	22x40	1.00
			25x20	0.90	22x30	0.90			22x35	0.95	30x25	0.90
					25x25	0.90			25x30	0.95		
120	22x20	0.78	22x30	1.00	22x30	0.95	22x30	0.95	22x30	0.95	30x30	1.00
			25x25	1.00	22x35	1.05			22x40	1.05	35x25	1.00
					25x25	1.05			25x30	1.05		
									30x25	1.05		
150	22x25	0.90	22x35	1.15	22x35	1.15	22x35	1.05	22x35	1.05	22x50	1.40
			25x30	1.15	25x30	1.15	25x30	1.05	22x45	1.20	30x35	1.20
			30x25	1.15	30x25	1.15	30x25	1.05	25x35	1.20		
									30x30	1.20		
180	22x25	1.05	22x40	1.30	22x40	1.20	22x40	1.35	25x40	1.35	30x40	1.40
	25x20	1.00	25x30	1.25	22x45	1.30			30x35	1.35	35x30	1.30
			30x25	1.25	25x35	1.30			35x25	1.35		
220					30x30	1.35						
	22x30	1.15	22x45	1.45	22x50	1.50	22x45	1.40	22x45	1.40		
	22x35	1.15	25x35	1.45	25x40	1.50	22x50	1.55	25x50	1.55	30x45	1.60
	25x25	1.15	30x30	1.45	30x30	1.50	25x40	1.50	30x40	1.55	35x35	1.50
270			35x25	1.45	35x25	1.50	25x45	1.60	35x30	1.55		
	22x30	1.30	25x40	1.65	22x50	1.60	25x40	1.50	25x50	1.55	30x50	1.80
	25x25	1.30	30x35	1.65	25x40	1.65	30x40	1.60	30x45	1.75	35x40	1.70
			35x25	1.65	30x35	1.65			35x35	1.70		
330					35x30	1.65						
	22x30	1.50	25x50	1.80	25x45	1.75	25x45	1.75	30x40	1.75		
	25x25	1.50	30x40	1.80	25x50	1.90	25x50	1.85	30x50	2.00	35x45	2.00
	30x25	1.50	35x30	1.80	30x40	1.90	30x40	1.75	35x40	2.00		
390					35x30	1.85	30x45	1.90				
	22x35	1.65	30x40	2.00	30x40	1.95	30x45	1.90	30x45	2.00	35x50	2.30
	25x35	1.65	35x30	2.00	30x45	2.15			35x45	2.25		
	30x25	1.65			35x35	2.10						
470	22x40	1.85	30x45	2.25	30x45	2.20	30x45	2.10	30x50	2.30		
	25x35	1.85	35x35	2.25	30x50	2.40	30x50	2.20	35x50	2.50		
	30x30	1.90			35x40	2.40						
	35x25	1.90										
560	22x45	2.10	35x40	2.50	30x50	2.45	30x50	2.30	35x50	2.70		
	25x40	2.10			35x45	2.70	35x45	2.30				
	30x30	2.10										
	35x25	2.10										
680	25x45	2.45	35x45	2.90	35x50	2.90			35x60	2.90		
	30x35	2.45										
	35x25	2.45										
820	30x45	2.75										
	35x30	2.75										
1000	30x45	3.30										
	35x35	3.30										
1200	35x40	3.55										
1500	35x45	4.05										

☆ Size: D ϕ x L (mm) ☆ Ripple Current : A/rms. 85°C, 120Hz

ALUMINUM ELECTROLYTIC CAPACITORS

LF Long Life Series

- Features : 85°C 3000 hours , Longer life than LH, Snap-in terminal, High ripple current
- Recommended Applications: Smoothing circuit, TV/Monitor, Adapter, SMPS
- Corresponding product to RoHS

LF
↑ Long Life
LH



Specifications

Item	Characteristics	
Operating Temperature Range	-40 ~ +85°C	-25 ~ +85°C
Rated Voltage Range	10 ~ 100VDC	160 ~ 450VDC
Capacitance Range	820 ~ 56000µF	56 ~ 2200µF
Capacitance Tolerance	± 20 % at 120Hz , 20°C	
Leakage Current (MAX) (20°C)	$I \leq 0.02CV$ or 3mA whichever is smaller (After rated voltage applied for 5 minutes) I = Leakage Current (µA) C = Nominal Capacitance (µF) V = Rated Voltage (V)	
Dissipation Factor (MAX) (tanδ) (120Hz ,20°C)	Dissipation Factor(tanδ) shall not exceed the values showed in the table of standard rating	
Endurance	After applying rated voltage with rated Ripple current for 3000hrs at 85°C , the capacitor shall meet the following requirement.	
	Capacitance Change	Within±20% of the initial value
	Dissipation Factor	Not more than 200% of the specified value
	Leakage Current	Not more than the specified value
Shelf Life	After placed at 85°C without voltage applied for 1000 hours, the capacitor shall meet the same requirements as Endurance.	

Diagram of Dimensions

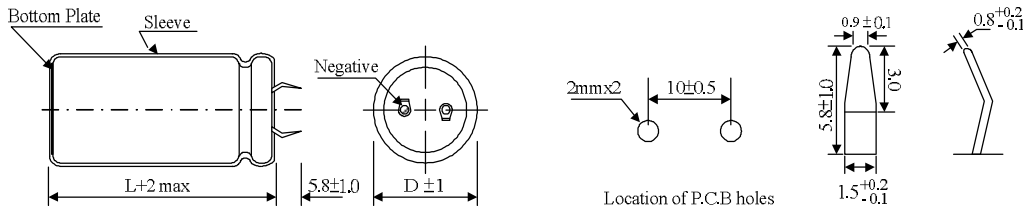

Multiplier for Ripple Current

Frequency coefficient

Freq. (Hz)	50	60	120	400	1K	2.4K	5K	10K
Coefficient	0.8	0.85	1.0	1.14	1.23	1.3	1.36	1.4

ALUMINUM ELECTROLYTIC CAPACITORS

LF Long Life Series

■ Dimensions, Max Dissipation Factor, Max Permissible Ripple Current, Max Equivalent Series Resistance

Capacitance (μF)	Rated (Surge) Voltage											
	10(13)					16(20)						
	ψDxL Ripple Current				tanδ	ESR	ψDxL Ripple Current				tanδ	ESR
8200									22x25			
							2.45					
10000							22x30				0.55	0.073
							2.60					
12000	22x25				0.55	0.061	22x35	25x25			0.55	0.061
	2.45						3.10	2.90				
15000	22x30				0.55	0.049	22x40	25x30	30x25		0.55	0.049
	2.80						3.46	3.30	3.40			
18000	22x35	25x25			0.55	0.041	22x45	25x35	30x30		0.55	0.041
	3.34	3.15					3.81	3.70	3.85			
22000	22x40	25x30	30x25		0.55	0.033	22x50	25x45	30x30	35x25	0.55	0.033
	3.67	3.50	3.60				4.32	4.40	4.15	4.23		
27000	22x45	25x35	30x30		0.55	0.027		25x45	30x35	35x30	0.55	0.027
	4.12	4.00	4.16				4.65	4.65	4.79			
33000	22x50	25x40	30x30	35x25	0.55	0.022			30x40	35x35	0.55	0.022
	4.63	4.49	4.45	4.54					5.25	5.41		
39000		25x45	30x35	35x30	0.55	0.019			30x45	35x35	0.55	0.019
		4.90	4.90	5.05					5.86	5.80		
47000		25x50	30x40	35x30	0.55	0.016				35x40	0.55	0.016
		5.55	5.61	5.50						6.45		
56000			30x45	35x35	0.55	0.013						
			6.11	6.05								

Capacitance (μF)	Rated (Surge) Voltage											
	25(32)					35(44)						
	ψDxL Ripple Current				tanδ	ESR	ψDxL Ripple Current				tanδ	ESR
3900									22x25			
							2.10					
4700							22x30	25x25			0.40	0.113
							2.30	2.30				
5600	22x25				0.45	0.107	22x35	25x30	30x25	35x25	0.40	0.095
	2.20						2.60	2.62	2.70	2.99		
6800	22x30	25x25			0.45	0.088	22x40	25x35	30x30	35x25	0.40	0.078
	2.45	2.45					2.90	2.93	3.07	3.13		
8200	22x35	25x30			0.45	0.073	22x45	25x35	30x30	35x25	0.40	0.065
	2.75	2.75					3.30	3.20	3.33	3.42		
10000	22x40	25x30	30x25		0.45	0.060	22x50	25x40	30x30	35x25	0.40	0.053
	3.25	3.10	3.19				3.74	3.64	3.60	3.67		
12000	22x45	25x35	30x30	35x25	0.45	0.050		25x45	30x35	35x30	0.40	0.044
	3.50	3.40	3.54	3.64				4.00	4.00	4.12		
15000		25x40	30x35	35x30	0.45	0.040			30x40	35x35	0.40	0.035
		3.90	4.10	4.21					4.60	4.74		
18000		25x45	30x40	35x30	0.45	0.033			30x45	35x40	0.40	0.029
		4.30	4.51	4.39					5.10	5.30		
22000			30x45	35x35	0.45	0.027				35x45	0.40	0.024
			4.90	4.85						5.70		
27000			30x50	35x40	0.45	0.022				35x50	0.40	0.020
			5.45	5.45						6.45		
33000			35x45		0.45	0.018						
			6.15									

☆Size: Dψx L (mm). ☆tanδ: 20°C, 120Hz. ☆Ripple Current: 85°C, 120Hz, (A/rms) ☆ESR: 20°C, 120Hz, (Ω).

ALUMINUM ELECTROLYTIC CAPACITORS

LF Long Life Series

■ Dimensions, Max Dissipation Factor, Max Permissible Ripple Current, Max Equivalent Series Resistance

Capacitance (μF)	Rated (Surge) Voltage											
	50(63)					63(79)						
	ψDxL Ripple Current				tanδ	ESR	ψDxL Ripple Current				tanδ	ESR
1800									22x25 1.80			
2200	22x25 1.80				0.35	0.211	22x30 2.00	25x25 2.00			0.30	0.181
2700	22x30 1.95				0.35	0.172	22x35 2.30	25x30 2.30			0.30	0.147
3300	22x35 2.33	25x25 2.20			0.35	0.141	22x40 2.68	25x30 2.55	30x25 2.63		0.30	0.121
3900	22x40 2.52	25x30 2.40			0.35	0.119	22x45 2.88	25x35 2.80	30x30 2.91		0.30	0.102
4700	22x45 2.78	25x35 2.70	30x30 2.82	35x25 2.89	0.35	0.099	22x50 3.28	25x40 3.18	30x30 3.15	35x25 3.21	0.30	0.085
5600		25x35 3.00	30x30 3.12	35x25 3.21	0.35	0.083		25x45 3.50	30x35 3.50	35x30 3.60	0.30	0.071
6800		25x40 3.35	30x35 3.52	35x30 3.62	0.35	0.068		25x50 3.94	30x40 3.98	35x30 3.90	0.30	0.059
8200		25x50 3.74	30x40 3.77	35x30 3.70	0.35	0.057			30x45 4.39	35x35 4.35	0.30	0.049
10000			30x45 4.24	35x35 4.20	0.35	0.046			30x50 4.90	35x40 4.90	0.30	0.040
12000			30x50 4.65	35x40 4.65	0.35	0.039				35x50 5.45	0.30	0.033
15000				35x45 5.30	0.35	0.031						
18000				35x50 5.90	0.35	0.026						

Capacitance (μF)	Rated (Surge) Voltage											
	80(100)					100(125)						
	ψDxL Ripple Current				tanδ	ESR	ψDxL Ripple Current				tanδ	ESR
820									22x25 1.70			
1000							22x30 1.95	25x25 1.95			0.25	0.332
1200	22x25 1.70				0.25	0.276	22x35 2.15	25x30 2.15			0.25	0.276
1500	22x30 1.95	25x25 1.95			0.25	0.221	22x40 2.57	25x30 2.45	30x25 2.52		0.25	0.221
1800	22x35 2.15	25x30 2.15			0.25	0.184	22x45 2.83	25x35 2.75	30x30 2.86		0.25	0.184
2200	22x40 2.57	25x30 2.45	30x25 2.52		0.25	0.151	22x50 3.17	25x40 3.08	30x30 3.05	35x25 3.11	0.25	0.151
2700	22x45 2.83	25x35 2.75	30x30 2.86		0.25	0.123		25x45 3.45	30x35 3.45	35x30 3.55	0.25	0.123
3300	22x50 3.22	25x40 3.13	30x30 3.10	35x25 3.16	0.25	0.100		25x50 3.94	30x40 3.98	35x30 3.90	0.25	0.100
3900		25x45 3.40	30x35 3.40	35x30 3.50	0.25	0.085			30x45 4.34	35x35 4.30	0.25	0.085
4700		25x50 3.84	30x40 3.88	35x35 4.04	0.25	0.071				35x40 4.75	0.25	0.071
5600			30x45 4.24	35x40 4.43	0.25	0.059				35x50 5.30	0.25	0.059
6800			30x50 4.70	35x45 4.93	0.25	0.049						
8200				35x50 5.25	0.25	0.040						

☆Size: Dψx L(mm). ☆tanδ: 20°C, 120Hz. ☆Ripple Current: 85°C, 120Hz, (A/rms) ☆ESR: 20°C, 120Hz, (Ω).

ALUMINUM ELECTROLYTIC CAPACITORS

LF Long Life Series

■ Dimensions, Max Dissipation Factor, Max Permissible Ripple Current, Max Equivalent Series Resistance

Capacitance (μF)	Rated (Surge) Voltage											
	160(200)					180(225)						
	ψDxL				tanδ	ESR	ψDxL				tanδ	ESR
	Ripple Current						Ripple Current					
270							22x25				0.15	0.737
							1.10					
330	22x25				0.15	0.603	22x30				0.15	0.603
	1.15						1.25					
390	22x30				0.15	0.510	22x30	25x25			0.15	0.510
	1.30						1.40	1.40				
470	22x35	25x30			0.15	0.423	22x35	25x30			0.15	0.423
	1.59	1.62					1.60	1.60				
560	22x35	25x30			0.15	0.355	22x40	25x30	30x25		0.15	0.355
	1.70	1.70					1.89	1.80	1.85			
680	22x40	25x35	30x25		0.15	0.293	22x45	25x35	30x30		0.15	0.292
	1.97	1.99	1.95				2.11	2.05	2.13			
820	22x50	25x40	30x30		0.15	0.243	22x50	25x40	30x30	35x30	0.15	0.243
	2.32	2.28	2.24				2.34	2.27	2.25	2.45		
1000		25x45	30x35	35x30	0.15	0.199		25x50	30x35	35x30	0.15	0.199
		2.58	2.57	2.65				2.67	2.55	2.63		
1200		25x50	30x40	35x35	0.15	0.166			30x40	35x35	0.15	0.166
		2.78	2.80	2.92					2.85	2.93		
1500			30x45	35x40	0.15	0.133			30x50	35x40	0.15	0.130
			3.03	3.17					3.10	3.10		
1800			30x50	35x45	0.15	0.111				35x45	0.15	0.111
			3.50	3.67						3.60		
2200			35x50		0.15	0.090						
			4.08									

Capacitance (μF)	Rated (Surge) Voltage											
	200(250)					250(300)						
	ψDxL				tanδ	ESR	ψDxL				tanδ	ESR
	Ripple Current						Ripple Current					
180							22x25				0.15	1.110
							1.00					
220	22x25	25x25			0.15	0.905	22x30	25x25			0.15	0.905
	1.00	1.08					1.15	1.15				
270	22x30	25x25			0.15	0.737	22x30	25x25			0.15	0.737
	1.15	1.15					1.30	1.30				
330	22x30	25x25			0.15	0.603	22x35	25x30			0.15	0.603
	1.29	1.30					1.45	1.45				
390	22x35	25x30	30x25		0.15	0.510	22x40	25x35	30x25		0.15	0.510
	1.45	1.45	1.51				1.62	1.63	1.60			
470	22x40	25x35	30x25		0.15	0.423	22x45	25x40	30x30	35x25	0.15	0.423
	1.67	1.68	1.65				1.80	1.84	1.80	1.85		
560	22x45	25x35	30x30		0.15	0.355		25x40	30x35	35x30	0.15	0.355
	1.94	1.87	1.96					2.00	2.10	2.20		
680	22x50	25x45	30x35	35x30	0.15	0.293		25x50	30x40	35x30	0.15	0.293
	2.14	2.21	2.20	2.27				2.32	2.35	2.30		
820		25x50	30x35	35x30	0.15	0.243			30x45	35x35	0.15	0.243
		2.32	2.22	2.30					2.57	2.55		
1000			30x45	35x35	0.15	0.199			30x50	35x40	0.15	0.199
			2.63	2.60					2.90	2.90		
1200			30x50	35x40	0.15	0.166				35x45	0.15	0.166
			2.90	2.90						3.25		
1500			35x45		0.15	0.133						
			3.11									

☆Size: Dψx L(mm). ☆tanδ: 20°C, 120Hz. ☆Ripple Current: 85°C, 120Hz, (A/rms) ☆ESR: 20°C, 120Hz, (Ω).

ALUMINUM ELECTROLYTIC CAPACITORS

LF Long Life Series

■Dimensions,Max Dissipation Factor,Max Permissible Ripple Current,Max Equivalent Series Resistance

Capacitance (μF)	Rated (Surge) Voltage											
	315(365)					350(400)						
	ψDxL				tanδ	ESR	ψDxL				tanδ	ESR
	Ripple Current						Ripple Current					
82							22x25				0.15	2.426
							0.70					
100	22x25				0.15	1.989	22x30				0.15	1.989
	0.75						0.80					
120	22x30				0.15	1.658	22x30	25x25			0.15	1.658
	0.80						0.85	0.85				
150	22x30	25x25			0.15	1.326	22x35	25x25			0.15	1.326
	1.00	1.00					1.11	1.05				
180	22x35	25x30			0.15	1.105	22x40	25x35	30x25		0.15	1.105
	1.10	1.10					1.16	1.17	1.15			
220	22x40	25x30	30x25		0.15	0.905	22x45	25x35	30x30	35x25	0.15	0.905
	1.31	1.25	1.29				1.34	1.30	1.35	1.39		
270	22x45	25x35	30x30	35x25	0.15	0.737		25x45	30x35	35x25	0.15	0.737
	1.44	1.40	1.46	1.50				1.51	1.49	1.45		
330	22x50	25x40	30x35	35x30	0.15	0.603		25x50	30x40	35x30	0.15	0.603
	1.63	1.60	1.68	1.74				1.67	1.68	1.65		
390		25x45	30x35	35x30	0.15	0.510			30x45	35x35	0.15	0.510
		1.75	1.75	1.80					1.87	1.85		
470			30x40	35x35	0.15	0.423			30x50	35x40	0.15	0.423
			2.00	2.06					2.10	2.10		
560			30x45	35x40	0.15	0.355				35x45	0.15	0.355
			2.20	2.29						2.30		
680				35x45	0.15	0.293				35x50	0.15	0.293
				2.50						2.60		
820				35x50	0.15	0.243						
				2.80								

Capacitance (μF)	Rated (Surge) Voltage											
	400(450)					450(500)						
	ψDxL				tanδ	ESR	ψDxL				tanδ	ESR
	Ripple Current						Ripple Current					
56							22x25				0.25	5.921
							0.65					
68	22x25				0.15	2.926	22x30				0.25	4.876
	0.65						0.75					
82	22x25				0.15	2.426	22x30	25x25			0.25	4.044
	0.75						0.85	0.85				
100	22x30	25x25			0.15	1.989	22x35	25x30			0.25	3.316
	0.85	0.85					0.90	0.90				
120	22x35	25x25	30x25		0.15	1.658	22x40	25x35	30x25		0.25	2.763
	0.99	0.93	1.04				1.11	1.12	1.10			
150	22x40	25x30	30x25		0.15	1.326	22x50	25x40	30x30		0.25	2.210
	1.15	1.10	1.13				1.25	1.21	1.20			
180	22x45	25x35	30x30		0.15	1.105		25x45	30x35	35x25	0.25	1.842
	1.24	1.20	1.25					1.40	1.39	1.35		
220	22x50	25x40	30x30	35x25	0.15	0.905		25x50	30x40	35x30	0.25	1.507
	1.40	1.36	1.35	1.38				1.51	1.53	1.50		
270		25x45	30x35	35x30	0.15	0.737			30x45	35x35	0.25	1.228
		1.50	1.50	1.54					1.72	1.70		
330		25x50	30x40	35x35	0.15	0.603			30x50	35x40	0.25	1.005
		1.70	1.70	1.77					1.90	1.90		
390			30x45	35x35	0.15	0.510				35x45	0.25	0.850
			1.92	1.90						2.10		
470				35x40	0.15	0.423				35x50	0.25	0.705
				2.10						2.30		
560				35x50	0.15	0.355						
				2.30								

☆Size:Dψx L(mm). ☆tanδ:20°C,120Hz. ☆Ripple Current: 85°C,120Hz,(A/rms) ☆ESR:20°C,120Hz,(Ω).

ALUMINUM ELECTROLYTIC CAPACITORS

LG High temperature and general purpose Series

- Endurance : 105°C 2000 hours, high temperature than LH
- Ideally suitable for using in Switching Power Supplies and other industrial /commercial applications
- Corresponding product to RoHS

LG
 ↑ High temperature
 LH



Specifications

Item	Characteristics										
Operating Temperature Range	-40 ~ +105°C -25 ~ +105°C										
Rated Voltage Range	6.3 ~ 100VDC 160 ~ 500VDC										
Capacitance Range	560 ~ 82000µF 47 ~ 2200µF										
Capacitance Tolerance	± 20 % at 120Hz , 20°C										
Leakage Current (MAX)	I=0.02CV, L=20m/m, I=0.03CV or 3mA , whichever is smaller. (At 20°C, After 5 minutes) Where, I : Leakage Current (µA) ; C:Nominal Capacitance(µF) ; V:Rated Voltage(v)										
Dissipation Factor (MAX) (tanδ) (120Hz ,20°C)	Rated voltage(V)	6.3	10	16	25	35	50	63~100	160~400	420~450	500
	tanδ	0.60	0.55	0.55	0.45	0.35	0.30	0.25	0.15	0.20	0.25
Low Temperature Stability Impedance Ratio (MAX)	Measurement frequency : 120Hz										
	Rated voltage(V)	6.3~16	25	35	50~63	80~100	160~400	420~450	500		
	Z-25°C / Z+20°C	4	3	3	2	2	4	8	8		
	Z-40°C / Z+20°C	15	10	8	6	5					
Endurance	After applying rated voltage with rated Ripple current for 2000hrs at 105°C , the capacitor shall meet the following requirements.										
	Capacitance Change	Within ± 20 % of initial value									
	Dissipation Factor	Not more than 200% of the specified value									
	Leakage Current	initial specified value or less									
Shelf Life	After placed at 105°C without voltage applied for 1000 hours, the capacitor shall meet the same requirement as Endurance.										

Diagram of Dimensions

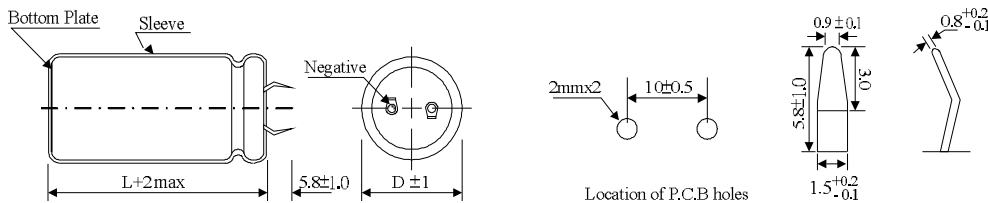

Multiplier for Ripple Current

Frequency coefficient

Frequency (Hz)	50	60	120	1K	10K
6.3~100V	0.88	0.90	1.00	1.15	1.16
160~250V	0.85	0.88	1.00	1.30	1.50
315~450V	0.88	0.90	1.00	1.35	1.45
500V	0.70	0.72	1.00	1.30	1.41

ALUMINUM ELECTROLYTIC CAPACITORS

LG

High temperature and general purpose Series

■ Dimensions, Rated Ripple Current

Capacitance (μF)	Rated (Surge) Voltage							
	6.3 (8)		10 (13)		16 (20)		25 (32)	
	Size	Ripple	Size	Ripple	Size	Ripple	Size	Ripple
4700							22x25	1.50
5600							22x30	1.65
							25x25	1.65
6800					22x25	1.55	22x30	1.85
							25x25	1.85
8200					22x30	1.70	22x35	2.10
					25x25	1.70	25x30	2.10
							30x25	2.15
10000			25x25	1.55	22x30	1.95	22x40	2.40
					25x25	1.95	25x35	2.40
							30x30	2.40
							35x25	2.40
12000	22x25	1.55	22x30	1.75	22x35	2.20	22x45	2.70
					25x30	2.25	25x40	2.75
					30x25	2.30	30x30	2.70
							35x25	2.75
15000	22x30	1.70	22x30	1.90	22x40	2.55	25x45	3.15
	25x25	1.70	25x25	1.90	25x35	2.60	30x35	3.15
					30x30	2.60	35x30	3.25
					35x25	2.65		
18000	22x30	1.95	22x35	2.20	22x45	2.90	25x50	3.55
	25x25	1.95	25x30	2.25	25x40	2.90	30x40	3.55
					30x30	2.90	35x35	3.55
					35x25	2.95		
22000	22x35	2.25	22x40	2.50	25x45	3.30	30x45	4.05
	25x30	2.25	25x35	2.55	30x35	3.30	35x35	3.80
	30x25	2.25	30x25	2.45	35x30	3.30		
27000	22x40	2.55	22x50	2.95	25x50	3.80	35x45	4.70
	25x35	2.55	25x40	2.90	30x40	3.75		
	30x30	2.55	30x30	2.85	35x30	3.75		
	35x25	2.55	35x25	2.80				
33000	22x45	2.90	25x45	3.30	30x45	4.30	35x50	5.40
	25x40	2.95	30x35	3.30	35x35	4.25		
	30x30	2.90	35x30	3.30				
	35x25	2.95						
39000	25x50	3.25	25x50	3.70	30x50	4.80	35x45	5.50
	30x35	3.25	30x40	3.7	35x40	4.80		
	35x30	3.30	35x30	3.65				
47000	25x50	3.70	30x45	4.20	35x45	5.45	35x50	6.00
	30x40	3.70	35x35	3.80				
56000	30x45	4.15	30x50	4.65	35x45	5.65		
	35x35	4.10	35x40	4.65				
68000	30x50	4.70	35x50	5.50	35x50	6.20		
	35x40	4.70						
82000	35x45	5.30						

☆ Size: D \times L (mm) ☆ Ripple Current : A/rms. 105°C, 120Hz

ALUMINUM ELECTROLYTIC CAPACITORS

LG

High temperature and general purpose Series

■ Dimensions, Rated Ripple Current

Capacitance (μF)	Rated (Surge) Voltage							
	35 (44)		50 (63)		63 (79)		80 (100)	
	Size	Ripple	Size	Ripple	Size	Ripple	Size	Ripple
820							22x25	1.10
1000							22x30	1.20
							25x25	1.20
1200					22x25	1.20	22x30	1.40
							25x25	1.40
1500					22x30	1.30	22x35	1.60
					25x25	1.30	25x30	1.60
							30x25	1.65
1800			22x25	1.30	22x30	1.50	22x40	1.80
					25x25	1.50	25x35	1.85
							30x25	1.80
2200			22x30	1.55	22x35	1.70	22x45	2.05
			25x25	1.55	25x30	1.75	25x35	2.00
					30x25	1.80	30x30	2.05
							35x25	2.05
2700			22x30	1.70	22x40	2.00	25x45	2.35
			25x25	1.70	25x35	2.00	30x35	2.35
					30x25	1.95	35x30	2.35
3300	22x25	1.40	22x35	1.95	22x50	2.30	25x50	2.70
			25x30	1.85	25x40	2.30	30x40	2.70
					30x30	2.25	35x30	2.55
					35x25	2.10		
3900	22x30	1.55	22x40	2.15	25x45	2.55	30x45	3.00
	25x25	1.55	25x35	2.20	30x35	2.55	35x35	3.00
			30x25	1.95	35x30	2.55		
4700	22x35	1.80	22x45	2.45	25x50	2.85	30x50	3.40
	25x25	1.80	25x40	2.45	30x40	2.85	35x40	3.40
			30x30	2.45	35x30	2.80		
			35x25	2.50				
5600	22x35	1.95	22x50	2.75	30x45	3.20	35x45	3.80
	25x30	1.95	25x40	2.70	35x35	3.20		
	30x25	2.00	30x35	2.75				
			35x30	2.75				
6800	22x40	2.20	25x50	3.30	30x50	3.65	35x50	3.90
	25x35	2.25	30x40	3.30	35x40	3.65		
	30x30	2.30	35x30	3.25				
	35x25	2.35						
8200	22x50	2.55	30x45	3.60	35x45	3.90		
	25x40	2.50	35x35	3.55				
	30x30	2.75						
	35x25	2.75						
10000	25x45	2.85	30x50	4.05	35x50	4.40		
	30x35	2.90	35x40	4.00				
	35x30	2.95						
12000	25x50	3.25	35x45	4.55				
	30x40	3.25						
	35x30	3.15						
15000	30x45	3.70						
	35x35	3.65						
18000	35x40	4.35						
22000	35x50	4.90						

☆ Size: D \times L (mm) ☆ Ripple Current : A/rms. 105°C, 120Hz

ALUMINUM ELECTROLYTIC CAPACITORS

LG

High temperature and general purpose
Series

■ Dimensions, Rated Ripple Current

Capacitance (μ F)	Rated (Surge) Voltage							
	100 (125)		160 (200)		180 (225)		200 (250)	
	Size	Ripple	Size	Ripple	Size	Ripple	Size	Ripple
150							22x20	0.65
180					22x20	0.75	22x20	0.70
220			22x20	0.80	22x25	0.85	22x25	0.80
							25x20	0.80
270			22x25	1.00	22x25	0.95	22x25	0.85
					25x20	0.90	25x25	0.85
330			22x25	1.20	22x25	1.20	22x30	1.20
			25x20	1.15	22x30	1.10	25x25	1.20
					25x25	1.10		
390			22x30	1.30	22x30	1.30	22x30	1.30
			25x25	1.30	25x25	1.30	22x35	1.30
							25x30	1.30
							30x25	1.30
470			22x30	1.30	22x30	1.30	22x35	1.40
			22x35	1.40	22x35	1.35	22x40	1.40
			25x25	1.40	25x30	1.40	25x30	1.40
					30x25	1.40	30x25	1.50
560	22x25	1.05	22x40	1.50	22x40	1.50	22x45	1.55
			25x30	1.50	25x35	1.55	25x35	1.55
			30x25	1.50	30x25	1.50	30x30	1.55
680	22x25	1.20	22x45	1.70	22x45	1.70	22x50	1.75
			25x35	1.70	22x50	1.70	25x40	1.75
			30x25	1.70	25x35	1.70	30x30	1.75
					25x40	1.75	35x25	1.70
					30x30	1.70		
					35x25	1.70		
820	22x30	1.30	22x50	1.95	22x50	1.95	25x50	2.05
	25x25	1.33	25x40	2.00	25x40	2.00	30x35	2.00
			30x30	2.00	25x45	2.00	35x30	2.05
			35x25	1.90	30x35	2.00		
					35x25	1.90		
1000	22x35	1.50	25x45	2.20	25x45	2.20	30x40	2.30
	25x30	1.50	30x35	2.20	25x50	2.20	30x45	2.30
			35x30	2.20	30x35	2.25	35x30	2.30
					30x40	2.25	35x35	2.30
					35x30	2.25		
1200	22x40	1.70	25x50	2.45	25x50	2.45	30x50	2.60
	25x35	1.70	30x40	2.45	30x40	2.45	35x40	2.65
	30x25	1.70	35x30	2.45	30x45	2.50		
					35x35	2.50		
1500	22x45	1.95	30x45	2.80	30x45	2.80	35x45	3.10
	25x40	2.00	35x35	2.80	30x50	2.90		
	30x30	1.95			35x40	2.90		
	35x25	2.00						
1800	25x45	2.20	30x50	3.30	30x50	3.30	35x50	3.15
	30x35	2.50	35x45	3.30	35x50	3.30		
	35x30	2.45						
2200	25x50	2.55	35x50	3.75	35x50	3.60		
	30x40	2.70						
	35x30	2.55						
2700	30x45	2.90						
	35x35	2.85						
3300	30x50	3.25						
	35x40	3.25						
3900	35x45	3.70						
4700	35x50	3.80						

☆ Size: D \times L (mm) ☆ Ripple Current : A/rms. 105°C, 120Hz

ALUMINUM ELECTROLYTIC CAPACITORS



High temperature and general purpose
Series

■ Dimensions, Rated Ripple Cur

Capacitance (μ F)	Rated (Surge) Voltage									
	250 (300)		350 (400)		400 (450)		420(470)		450 (500)	
	Size	Ripple	Size	Ripple	Size	Ripple	Size	Ripple	Size	Ripple
47					22x20	0.35			22x25	0.38
56			22x20	0.40	22x20	0.40			22x25	0.40
68			22x25	0.45	22x25	0.50			22x30	0.50
					25x20	0.50			25x25	0.50
82			22x25	0.55	22x25	0.52			22x30	0.52
			25x20	0.50	22x30	0.60			22x35	0.55
					25x25	0.65			25x30	0.55
									30x25	0.55
100			22x30	0.70	22x30	0.60			22x30	0.55
			25x25	0.70	22x35	0.65			22x40	0.65
					25x30	0.65			25x30	0.60
									30x25	0.65
120	22x20	0.60	22x35	0.75	22x30	0.62			22x35	0.60
			25x30	0.75	22x35	0.70			22x45	0.70
			30x25	0.75	25x30	0.70			25x35	0.70
					30x25	0.75			30x30	0.70
150									35x25	0.70
	22x25	0.65	22x40	0.80	22x35	0.72	22x35	0.58	22x40	0.68
			25x30	0.80	22x40	0.80	22x40	0.65	22x50	0.80
			30x25	0.85	25x30	0.85	25x30	0.70	25x40	0.80
					25x35	0.85			30x30	0.75
					30x30	0.85			35x25	0.75
180					35x25	0.80				
	22x25	0.80	22x45	0.90	22x40	0.81	22x40	0.68	22x45	0.75
	25x20	0.75	25x35	0.90	22x50	0.95	25x35	0.68	25x45	0.85
			30x30	0.90	25x40	0.95			30x35	0.85
					30x30	0.90			35x30	0.85
220	22x30	0.95	22x50	1.05	25x45	1.05	25x40	0.85	22x50	0.85
	25x25	0.95	25x40	1.05	30x35	1.05	25x45	0.95	25x50	1.00
			30x30	1.00	35x30	1.10	30x40	0.95	30x40	1.00
			35x25	1.05					35x30	1.00
270	22x35	1.15	25x45	1.20	25x45	1.10	25x45	1.05	25x50	1.05
	25x30	1.15	30x35	1.20	25x50	1.20	30x40	1.05	30x45	1.15
	30x25	1.15	35x30	1.20	30x40	1.20	35x30	1.05	35x35	1.15
					35x35	1.20				
330	22x40	1.25	30x40	1.35	25x50	1.25	25x50	1.15	30x45	1.25
	25x30	1.20	35x35	1.35	30x45	1.40	30x40	1.15	30x50	1.40
	30x25	1.25			35x35	1.35	35x35	1.15	35x40	1.40
390	22x45	1.5	30x45	1.50	30x45	1.42	30x45	1.25	30x50	1.40
	25x35	1.50	35x35	1.50	30x50	1.55			35x45	1.55
	30x30	1.50			35x40	1.55				
470	22x50	1.55	35x40	1.70	30x45	1.45	30x50	1.40	35x45	1.68
	25x40	1.55			35x40	1.65	35x40	1.35	35x50	1.70
	30x30	1.55			30x50	1.75				
	35x25	1.55			35x45	1.75				
560	25x45	1.80	35x45	1.90	35x45	1.80	35x45	1.65	35x50	1.80
	30x35	1.80			30x60	1.90			35x60	2.10
	35x30	1.80			35x50	1.90				
680	25x50	1.95			35x50	2.10				
	30x40	2.00			35x60	2.15				
	35x35	2.00								
820	30x45	2.15								
	35x35	2.10								
1000	35x40	2.30								
1500	35x50	3.63								

☆ Size: D \times L (mm) ☆ Ripple Current : A/rms. 105°C, 120Hz

ALUMINUM ELECTROLYTIC CAPACITORS

LG

High temperature and general purpose
Series

■ Dimensions, Rated Ripple Current

Capacitance (μ F)	Rated (Surge) Voltage	
	500 (550)	
	Size	Ripple
47	22x25	0.51
56	22x30	0.58
68	25x25	0.65
82	22x35	0.72
	25x30	0.74
100	22x45	0.83
	30x25	0.82
120	22x50	0.93
	25x35	0.93
	30x30	0.91
150	25x45	1.08
	30x35	1.04
	35x25	0.99
180	25x50	1.20
	30x40	1.17
	35x30	1.10
220	30x45	1.33
	35x35	1.23
270	30x50	1.50
	35x40	1.42
330	35x45	1.60
390	35x50	1.78
470	35x60	2.03

☆ Size: D \times L (mm) ☆ Ripple Current : A/rms, 105°C, 120Hz

ALUMINUM ELECTROLYTIC CAPACITORS

LS High temperature and Smaller Size Series

- Endurance : 105°C 2000 hours, smaller size than LG
- Ideally suitable for using in Switching Power Supplies and other industrial /commercial applications
- Corresponding product to RoHS

LS
↑
LG Smaller size



Specifications

Item	Characteristics						
Operating Temperature Range	-25 ~ +105°C						
Rated Voltage Range	160 ~ 450VDC						
Capacitance Range	100 ~ 3300µF						
Capacitance Tolerance	± 20 % at 120Hz , 20°C						
Leakage Current (MAX)	I=0.02CV or 3mA , whichever is smaller.(At 20°C, After 5 minutes) Where, I :Leakage Current (µA) ; C:Nominal Capacitance(µF) ; V:Rated Voltage(v)						
Dissipation Factor (MAX) (tanδ) (120Hz ,20°C)	<table border="1"> <thead> <tr> <th>Rated voltage(V)</th> <th>160~400</th> <th>420~450</th> </tr> </thead> <tbody> <tr> <td>tanδ</td> <td>0.15</td> <td>0.20</td> </tr> </tbody> </table>	Rated voltage(V)	160~400	420~450	tanδ	0.15	0.20
Rated voltage(V)	160~400	420~450					
tanδ	0.15	0.20					
Low Temperature Stability Impedance Ratio (MAX)	Measurement frequency : 120Hz <table border="1"> <thead> <tr> <th>Rated voltage(V)</th> <th>160~400</th> <th>420~450</th> </tr> </thead> <tbody> <tr> <td>Z-25°C / Z+20°C</td> <td>4</td> <td>8</td> </tr> </tbody> </table>	Rated voltage(V)	160~400	420~450	Z-25°C / Z+20°C	4	8
Rated voltage(V)	160~400	420~450					
Z-25°C / Z+20°C	4	8					
Endurance	After applying rated voltage with rated Ripple current for 2000hrs at 105°C , the capacitor shall meet the following requirements. <table border="1"> <tbody> <tr> <td>Capacitance Change</td> <td>Within ± 20 % of initial value</td> </tr> <tr> <td>Dissipation Factor</td> <td>Not more than 200% of the specified value</td> </tr> <tr> <td>Leakage Current</td> <td>initial specified value or less</td> </tr> </tbody> </table>	Capacitance Change	Within ± 20 % of initial value	Dissipation Factor	Not more than 200% of the specified value	Leakage Current	initial specified value or less
Capacitance Change	Within ± 20 % of initial value						
Dissipation Factor	Not more than 200% of the specified value						
Leakage Current	initial specified value or less						
Shelf Life	After placed at 105°C without voltage applied for 1000 hours, the capacitor shall meet the same requirement as Endurance.						

Diagram of Dimensions

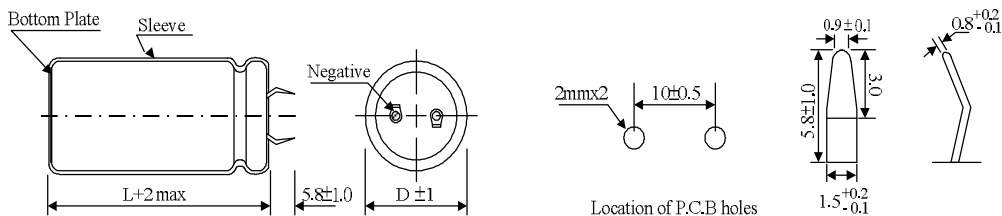

Multiplier for Ripple Current

Frequency coefficient

Frequency	50	60	120	1K	10K
160~250V	0.85	0.88	1.00	1.30	1.50
315~450V	0.88	0.9	1.00	1.35	1.45

ALUMINUM ELECTROLYTIC CAPACITORS

LS

High temperature and Smaller-size Series

■ Dimensions, Rated Ripple Current

Capacitance (μ F)	Rated (Surge) Voltage							
	160 (200)		200 (250)		220 (270)		250 (300)	
	Size	Ripple	Size	Ripple	Size	Ripple	Size	Ripple
330					22x25	1.26		
390					22x30	1.34	22x30	1.08
							25x25	1.08
470			22x30	1.20	22x35	1.48	22x35	1.17
					25x30	1.40	25x30	1.30
560	22x30	1.40	22x35	1.48	22x40	1.45	22x40	1.40
			25x30	1.48	25x30	1.45	25x35	1.50
							30x25	1.26
680	22x35	1.50	22x40	1.60	22x40	1.49	22x45	1.35
	25x30	1.70	25x35	1.60	25x35	1.78	25x40	1.70
					30x30	1.65	30x30	1.70
820	22x40	2.00	22x45	1.75	22x50	1.93		
	25x35	2.00	25x40	1.75	25x40	1.93	25x45	2.00
			30x30	1.75	30x30	1.85	30x35	2.00
					35x25	1.93	35x30	2.00
1000	22x50	2.10			25x45	2.15		
	25x40	2.20	25x45	2.04	30x35	2.33	25x50	2.20
	30x30	2.20	30x35	2.04	35x30	2.33	30x40	2.20
							35x30	2.00
1200								
	25x45	2.30	25x50	2.30				
	30x35	2.30	30x40	2.30	30x40	2.50	30x45	2.30
			35x30	2.30	35x30	2.12	35x35	2.20
1500	25x50	2.50						
	30x40	2.50	30x45	2.57	30x45	2.30		
	35x30	2.50	35x35	2.57	35x35	2.25	35x40	2.30
1800								
	30x45	2.70	30x50	2.41				
	35x35	2.55	35x40	2.68	35x40	2.43	35x50	2.50
2200	30x50	2.90						
	35x45	2.90	35x45	2.63	35x50	2.95		
2700	35x50	3.00	35x55	3.27				
3300	35x60	3.10						

☆ Size: D \times L (mm) ☆ Ripple Current : A/rms. 105°C, 120Hz

ALUMINUM ELECTROLYTIC CAPACITORS

LS

High temperature and Smaller-size Series

■ Dimensions, Rated Ripple Current

Capacitance (μ F)	Rated (Surge) Voltage					
	400 (450)		420(470)		450 (500)	
	Size	Ripple	Size	Ripple	Size	Ripple
100					22x25	0.50
120	22x25	0.61	22x25	0.46	22x30	0.60
150			22x30	0.54	22x35	0.72
			25x25	0.65	25x25	0.73
180	22x30	0.68	22x35	0.64	22x40	0.79
	25x25	0.66	25x30	0.64	25x30	0.71
220	22x35	0.80	22x40	0.80	22x45	0.87
	25x30	0.77	25x35	0.80	25x35	0.78
			30x25	0.80	30x25	0.83
270	22x40	0.95	22x50	1.00	22x50	0.95
	25x35	1.00	25x40	1.00	25x40	0.90
	30x25	0.93	30x30	1.00	30x35	1.05
					35x25	0.95
330	22x50	1.04	25x45	1.10	25x50	1.20
	25x40	1.04	30x35	1.10	30x35	1.14
	30x30	1.08	35x30	1.10	35x30	1.20
	35x25	1.04				
390	25x45	1.26	25x50	1.20	30x40	1.31
	30x35	1.26	30x40	1.20	35x35	1.38
	35x30	1.55	35x30	1.20		
470	30x40	1.40	30x45	1.30	30x45	1.48
	35x30	1.46	35x35	1.30	35x35	1.47
560	30x45	1.56	30x50	1.60	35x40	1.62
	35x35	1.54	35x40	1.60		
680	30x50	1.72	35x45	2.00	35x50	1.91
	35x40	1.70				
820	35x45	1.91	35x50	2.30		

☆ Size: D \times L (mm) ☆ Ripple Current : A/rms. 105°C, 120Hz

ALUMINUM ELECTROLYTIC CAPACITORS

LJ

High temperature and long life Series

- Features : 105°C 3000 hours , Wide temperature range for LF , Longer life than LG, Snap-in terminal, High ripple current
- Recommended Applications: Smoothing circuit, TV/Monitor, Adapter, SMPS
- Corresponding product to RoHS

LJ
↑
LG

Long Life



Specifications

Item	Characteristics	
Operating Temperature Range	-40 ~ +105°C	-25 ~ +105°C
Rated Voltage Range	10 ~ 100VDC	160 ~ 500VDC
Capacitance Range	560 ~ 68000µF	56 ~ 2200µF
Capacitance Tolerance	± 20 % at 120Hz , 20°C	
Leakage Current (MAX) (20°C)	I ≤ 0.02CV or 3mA whichever is smaller (After rated voltage applied for 5 minutes) I = Leakage Current (µA) C= Nominal Capacitance (µF) V= Rated Voltage (V)	
Dissipation Factor (MAX) (tanδ) (120Hz , 20°C)	Dissipation Factor(tanδ) shall not exceed the values showed in the table of standard rating	
Endurance	After applying rated voltage with rated Ripple current for 3000hrs at 105°C , the capacitor shall meet the following requirement.	
	Capacitance Change	Within ±20% of the initial value
	Dissipation Factor	Not more than 200% of the specified value
	Leakage Current	Not more than the specified value
Shelf Life	After placed at 105°C without voltage applied for 1000 hours, the capacitor shall meet the same requirements as Endurance.	

Diagram of Dimensions

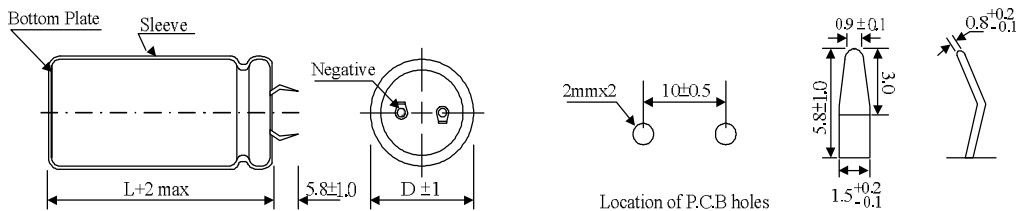

Multiplier for Ripple Current

Frequency coefficient

Freq. (Hz)	50	60	120	400	1K	2.4K	5K	10K
10~450V	0.80	0.85	1.00	1.14	1.23	1.30	1.36	1.40
500V	0.70	0.72	1.00	1.16	1.30	1.32	1.36	1.41

ALUMINUM ELECTROLYTIC CAPACITORS



High temperature and long life Series

■ Dimensions, Max Dissipation Factor, Max Permissible Ripple Current, Max Equivalent Series Resistance

Capacitance (μF)	Rated (Surge) Voltage											
	10(13)						16(20)					
	ψDxL			tanδ	ESR	ψDxL			tanδ	ESR		
	Ripple Current					Ripple Current						
6800						22x25					0.55	0.107
						1.80						
8200						22x30	25x25				0.55	0.089
						2.05	2.05					
10000	22x25				0.55	0.073	22x35	25x30			0.55	0.073
	1.80						2.45	2.45				
12000	22x30	25x25			0.55	0.061	22x40	25x30	30x25		0.55	0.061
	2.05	2.05					2.73	2.60	2.68			
15000	22x35	25x30	30x25		0.55	0.049	22x45	25x35	30x30		0.55	0.049
	2.45	2.45	2.55				2.99	2.90	3.02			
18000	22x40	25x30	30x30		0.55	0.041	22x50	25x40	30x30	35x25	0.55	0.041
	2.94	2.80	3.11				3.43	3.33	3.30	3.37		
22000	22x45	25x35	30x30	35x25	0.55	0.033		25x45	30x35	35x30	0.55	0.033
	3.24	3.15	3.28	3.37				3.70	3.70	3.81		
27000		25x40	30x35	35x30	0.55	0.027			30x40	35x35	0.55	0.027
		3.5	3.67	3.78					4.15	4.27		
33000		25x45	30x40	35x30	0.55	0.022			30x50	35x40	0.55	0.022
		4.00	4.20	4.08					4.65	4.65		
39000		25x50	30x45	35x35	0.55	0.019				35x45	0.55	0.019
		4.45	4.67	4.63						5.25		
47000				35x40	0.55	0.016				35x50	0.55	0.016
				4.90						5.80		
56000				35x45	0.55	0.013						
				5.50								
68000				35x50	0.55	0.011						
				6.05								

Capacitance (μF)	Rated (Surge) Voltage											
	25(32)						35(44)					
	ψDxL			tanδ	ESR	ψDxL			tanδ	ESR		
	Ripple Current					Ripple Current						
2700						22x25					0.40	0.196
						1.45						
3300						22x30					0.40	0.161
						1.60						
3900	22x25				0.45	0.153	22x30				0.40	0.136
	1.50						1.80					
4700	22x30				0.45	0.127	22x35	25x25			0.40	0.113
	1.80						2.23	2.10				
5600	22x30	25x25			0.45	0.107	22x40	25x30	30x25		0.40	0.095
	1.95	1.95					2.41	2.30	2.37			
6800	22x35	25x30			0.45	0.088	22x45	25x35	30x30		0.40	0.078
	2.20	2.20					2.68	2.60	2.70			
8200	22x40	25x35	30x25		0.45	0.073	22x50	25x40	30x30	35x25	0.40	0.065
	2.47	2.50	2.45				3.02	2.93	2.90	2.96		
10000	22x45	25x40	30x30		0.45	0.060		25x45	30x35	35x30	0.40	0.0531
	2.75	2.80	2.75					3.20	3.20	3.30		
12000	22x50	25x45	30x35	35x25	0.45	0.050		25x50	30x40	35x30	0.40	0.044
	3.13	3.22	3.19	3.10				3.64	3.67	3.6		
15000		25x50	30x40	35x30	0.45	0.040			30x45	35x35	0.40	0.035
		3.43	3.47	3.40					4.04	4.00		
18000			30x45	35x35	0.45	0.033				35x40	0.40	0.029
			3.94	3.90						4.60		
22000			30x50	35x40	0.45	0.027				35x50	0.40	0.024
			4.30	4.30						5.10		
27000				35x45	0.45	0.022						
				4.85								

☆Size: D \times L (mm). ☆tanδ: 20°C, 120Hz. ☆Ripple Current: 105°C, 120Hz, (A/rms) ☆ESR: 20°C, 120Hz, (Ω).

ALUMINUM ELECTROLYTIC CAPACITORS



High temperature and long life Series

■ Dimensions, Max Dissipation Factor, Max Permissible Ripple Current, Max Equivalent Series Resistance

Capacitance (μF)	Rated (Surge) Voltage											
	50(63)					63(79)						
	ψDxL				tanδ	ESR	ψDxL			tanδ	ESR	
	Ripple Current						Ripple Current					
1200							22x25				0.30	0.332
							1.25					
1500	22x25				0.35	0.309	22x30	25x25			0.30	0.265
	1.25						1.45	1.45				
1800	22x30				0.35	0.258	22x35	25x30			0.30	0.221
	1.45						1.6	1.6				
2200	22x30	25x25			0.35	0.211	22x40	25x30	30x25		0.30	0.181
	1.6	1.6					1.89	1.8	1.85			
2700	22x35	25x30			0.35	0.172	22x45	25x35	30x30		0.30	0.147
	1.8	1.8					2.06	2	2.08			
3300	22x40	25x30	30x25		0.35	0.141		25x40	30x30	35x25	0.30	0.121
	2.05	1.95	2.01					2.32	2.3	2.35		
3900	22x45	25x35	30x30		0.35	0.119		25x45	30x35	35x30	0.30	0.102
	2.27	2.2	2.29					2.55	2.55	2.63		
4700	22x50	25x40	30x30	35x25	0.35	0.099		25x50	30x40	35x30	0.30	0.085
	2.5	2.42	2.4	2.45				2.83	2.86	2.8		
5600		25x45	30x35	35x30	0.35	0.083			30x45	35x35	0.30	0.071
		2.7	2.7	2.78					3.18	3.15		
6800			30x40	35x30	0.35	0.068			30x50	35x40	0.30	0.059
			3.06	3					3.5	3.5		
8200			30x45	35x35	0.35	0.057				35x45	0.30	0.049
			3.38	3.35						3.9		
10000				35x40	0.35	0.046						
				3.7								
12000				35x50	0.35	0.039						
				4.20								

Capacitance (μF)	Rated (Surge) Voltage											
	80(100)					100(125)						
	ψDxL				tanδ	ESR	ψDxL			tanδ	ESR	
	Ripple Current						Ripple Current					
560							22x25				0.25	0.592
							1.20					
680							22x30				0.25	0.488
							1.35					
820	22x25				0.25	0.404	22x30	25x25			0.25	0.404
	1.20						1.50	1.50				
1000	22x30				0.25	0.332	22x35	25x30			0.25	0.332
	1.35						1.70	1.70				
1200	22x35	25x25			0.25	0.276	22x40	25x35	30x25		0.25	0.276
	1.59	1.50					1.97	1.99	1.95			
1500	22x40	25x30	30x25		0.25	0.221	22x45	25x40	30x30	35x25	0.25	0.221
	1.78	1.70	1.75				2.15	2.19	2.15	2.21		
1800	22x45	25x35	30x30		0.25	0.184		25x45	30x35	35x30	0.25	0.184
	2.01	1.95	2.03					2.45	2.45	2.52		
2200		25x40	30x30	35x25	0.25	0.151		25x50	30x40	35x35	0.25	0.151
		2.17	2.15	2.19				2.75	2.75	2.86		
2700		25x45	30x35	35x30	0.25	0.123			30x45	35x35	0.25	0.123
		2.45	2.45	2.52					3.08	3.05		
3300			30x40	35x35	0.25	0.100			30x50	35x40	0.25	0.100
			2.75	2.83					3.45	3.45		
3900			30x45	35x35	0.25	0.085				35x45	0.25	0.085
			3.13	3.10						3.90		
4700				35x40	0.25	0.071				35x50	0.25	0.071
				3.40						4.30		
5600				35x50	0.25	0.059						
				3.80								

☆Size: Dψx L(mm). ☆tanδ: 20°C, 120Hz. ☆Ripple Current: 105°C, 120Hz, (A/rms) ☆ESR: 20°C, 120Hz, (Ω).

ALUMINUM ELECTROLYTIC CAPACITORS



High temperature and long life Series

■ Dimensions, Max Dissipation Factor, Max Permissible Ripple Current, Max Equivalent Series Resistance

Capacitance (μF)	Rated (Surge) Voltage											
	160(200)						180(225)					
	ψDxL				tanδ	ESR	ψDxL				tanδ	ESR
	Ripple Current						Ripple Current					
270	22x25				0.15	0.737	22x25				0.15	0.737
	0.85						0.85					
330	22x30				0.15	0.603	22x30				0.15	0.603
	1.00						1.10					
390	22x30	25x25			0.15	0.51	22x35	25x25			0.15	0.51
	1.15	1.15					1.32	1.25				
470	22x35	25x30			0.15	0.423	22x40	25x30			0.15	0.423
	1.30	1.30					1.47	1.40				
560	22x40	25x30	30x25		0.15	0.355	22x45	25x35	30x25		0.15	0.355
	1.57	1.50	1.54				1.70	1.63	1.60			
680	22x45	25x35	30x30		0.15	0.293	22x50	25x40	30x30	35x25	0.15	0.293
	1.75	1.70	1.77				1.87	1.82	1.80	1.84		
820	22x50	25x40	30x30	35x25	0.15	0.243		25x45	30x35	35x30	0.15	0.243
	2.03	1.97	1.95	1.99				2.05	2.05	2.11		
1000		25x45	30x35	35x30	0.15	0.199		25x50	30x40	35x30	0.15	0.199
		2.15	2.15	2.21				2.27	2.29	2.25		
1200			30x40	35x35	0.15	0.166			30x45	35x35	0.15	0.166
			2.45	2.52				2.57	2.55			
1500			30x50	35x40	0.15	0.133				35x40	0.15	0.133
			2.75	2.75					2.85			
1800				35x45	0.15	0.111				35x50	0.15	0.111
				3.00					3.10			
2200				35x50	0.15	0.09						
				3.50								

Capacitance (μF)	Rated (Surge) Voltage											
	200(250)						250(300)					
	ψDxL				tanδ	ESR	ψDxL				tanδ	ESR
	Ripple Current						Ripple Current					
150							22x25				0.15	1.330
							0.75					
180							22x30				0.15	1.110
							0.85					
220	22x25				0.15	0.905	22x30	25x25			0.15	0.905
	0.85						1.00	1.00				
270	22x30				0.15	0.737	22x35	25x25			0.15	0.737
	1.00						1.22	1.15				
330	22x30	25x25			0.15	0.603	22x40	25x30			0.15	0.603
	1.15	1.15					1.36	1.30				
390	22x35	25x30			0.15	0.510	22x45	25x35	30x25	35x25	0.15	0.510
	1.30	1.30					1.54	1.48	1.45	1.59		
470	22x40	25x35	30x25		0.15	0.423	22x50	25x40	30x30	35x30	0.15	0.423
	1.52	1.54	1.49				1.78	1.75	1.72	1.88		
560	22x45	25x35	30x30		0.15	0.355		25x40	30x35	35x30	0.15	0.355
	1.7	1.65	1.72					1.80	1.89	1.94		
680		25x45	30x35	35x30	0.15	0.293		25x50	30x40	35x35	0.15	0.293
		1.97	1.97	2.02				2.10	2.10	2.18		
820		25x45	30x35	35x30	0.15	0.243			30x45	35x40	0.15	0.243
		2.20	2.10	2.16					2.30	2.39		
1000			30x45	35x35	0.15	0.199			30x50	35x45	0.15	0.199
			2.32	2.30					2.55	2.65		
1200			30x50	35x40	0.15	0.166				35x50	0.15	0.166
			2.75	2.75					2.90			
1500				35x45	0.15	0.133						
				2.90								

☆Size: Dψx L(mm). ☆tanδ: 20°C, 120Hz. ☆Ripple Current: 105°C, 120Hz, (A/rms) ☆ESR: 20°C, 120Hz, (Ω).

ALUMINUM ELECTROLYTIC CAPACITORS



High temperature and long life Series

■ Dimensions, Max Dissipation Factor, Max Permissible Ripple Current, Max Equivalent Series Resistance

Capacitance (μF)	Rated (Surge) Voltage										
	315(365)					350(400)					
	ψDxL Ripple Current			tanδ	ESR	ψDxL Ripple Current			tanδ	ESR	
82	22x25					0.15	2.426	22x25			
	0.55			0.60							
100	22x30			0.15	1.989	22x30	25x25		0.15	1.989	
	0.65					0.70	0.70				
120	22x30	25x25		0.15	1.658	22x35	25x30		0.15	1.658	
	0.75	0.75				0.80	0.80				
150	22x35	25x30		0.15	1.326	22x40	25x35	30x25	0.15	1.326	
	0.8	0.80				0.86	0.87	0.85			
180	22x40	25x35	30x25	0.15	1.105	22x45	25x40	30x30	0.15	1.105	
	1.01	1.02	1.00			1.05	1.07	1.05			
220	22x45	25x40	30x30	0.15	0.905	22x50	25x45	30x35	35x25	0.15	0.905
	1.10	1.12	1.10			1.16	1.20	1.18	1.15		
270		25x45	30x35	0.15	0.737		25x50	30x40	35x30	0.15	0.737
		1.25	1.25				1.31	1.33	1.3		
330		25x50	30x40	35x30	0.15	0.603		30x45	35x35	0.15	0.603
		1.53	1.53	1.50				1.46	1.45		
390			30x45	35x30	0.15	0.510		30x50	35x40	0.15	0.510
			1.71	1.60				1.65	1.65		
470			30x50	35x35	0.15	0.423			35x45	0.15	0.423
			1.85	1.75				1.85			
560				35x40	0.15	0.355			35x50	0.15	0.355
				2.00				2.10			
680				35x45	0.15	0.293					
				2.20							

Capacitance (μF)	Rated (Surge) Voltage											
	400(450)					450(500)						
	ψDxL Ripple Current			tanδ	ESR	ψDxL Ripple Current			tanδ	ESR		
56								22x25				
				0.55								
68	22x25			0.15	2.926	22x30			0.25	4.876		
	0.55					0.65						
82	22x30	25x25		0.15	2.426	22x35	25x25		0.25	4.044		
	0.65	0.65				0.80	0.75					
100	22x35	25x25		0.15	1.989	22x40	25x30		0.25	3.316		
	0.79	0.75				0.89	0.85					
120	22x40	25x30	30x25	0.15	1.658	22x45	25x35	30x25	0.25	2.763		
	0.89	0.85	0.87			0.95	0.92	0.90				
150	22x45	25x35	30x30	35x25	0.15	1.326	22x50	25x40	30x30	0.25	2.210	
	0.93	0.90	0.94	0.96			1.14	1.11	1.10			
180	22x50	25x40	30x30	35x25	0.15	1.105		25x45	30x35	35x25	0.25	1.842
	1.14	1.11	1.10	1.12				1.25	1.24	1.20		
220		25x45	30x35	35x30	0.15	0.905		25x50	30x40	35x30	0.25	1.507
		1.20	1.20	1.24				1.36	1.38	1.35		
270		25x50	30x40	35x30	0.15	0.737			30x45	35x35	0.25	1.228
		1.36	1.38	1.35					1.51	1.50		
330			30x45	35x35	0.15	0.603			30x50	35x40	0.25	1.005
			1.51	1.50					1.70	1.70		
390			30x50	35x40	0.15	0.510				35x45	0.25	0.850
			1.70	1.70					1.90			
470				35x45	0.15	0.423				35x50	0.25	0.705
				1.90					2.10			

☆Size: D \times L(mm). ☆tan δ : 20°C, 120Hz. ☆Ripple Current: 105°C, 120Hz, (A/rms) ☆ESR: 20°C, 120Hz, (Ω).

ALUMINUM ELECTROLYTIC CAPACITORS



**High temperature and long life
Series**

■ Dimensions, Max Dissipation Factor, Max Permissible Ripple Current, Max Equivalent Series Resistance

Capacitance (μ F)	Rated (Surge) Voltage					tan δ	ESR
	500(550)						
	ψ DxL			Ripple Current			
47	22x25						
	0.51						
56	22x30					0.25	5.912
	0.58						
68		25x25				0.25	4.876
		0.65					
82	22x35	25x30				0.25	4.044
	0.72	0.74					
100	22x45	30x25				0.25	3.316
	0.83	0.82					
120	22x50	25x35	30x30			0.25	2.763
	0.93	0.93	0.91				
150		25x45	30x35	35x25		0.25	2.210
		1.08	1.04	0.99			
180		25x50	30x40	35x30		0.25	1.842
		1.20	1.17	1.10			
220			30x45	35x35		0.25	1.507
			1.33	1.23			
270			30x50	35x40		0.25	1.228
			1.50	1.42			
330				35x45		0.25	1.005
				1.60			
390				35x50		0.25	0.850
				1.78			
470				35x60		0.25	0.705
				2.03			

☆Size:D ψ x L(mm). ☆tan δ :20 $^{\circ}$ C,120Hz. ☆Ripple Current: 105 $^{\circ}$ C,120Hz,(A/rms) ☆ESR:20 $^{\circ}$ C,120Hz,(Ω).

ALUMINUM ELECTROLYTIC CAPACITORS

LM

High temperature and Smaller Size Series

- Features : 105°C 3000 hours , Smaller size than LJ , Longer life than LS, Snap-in terminal, High ripple current
- Recommended Applications: Smoothing circuit, TV/Monitor, Adapter, SMPS
- Corresponding product to RoHS

LM
↑
LJ

Smaller size



Specifications

Item	Characteristics						
Operating Temperature Range	-25 ~ +105°C						
Rated Voltage Range	400 ~ 450VDC						
Capacitance Range	82 ~ 1000µF						
Capacitance Tolerance	± 20 % at 120Hz , 20°C						
Leakage Current (MAX) (20°C)	$I \leq 0.02CV$ or 3mA whichever is smaller (After rated voltage applied for 5 minutes) $I =$ Leakage Current (µA) $C =$ Nominal Capacitance (µF) $V =$ Rated Voltage (V)						
Dissipation Factor (MAX) (tanδ) (120Hz , 20°C)	<table border="1"> <thead> <tr> <th>Rated voltage(V)</th> <th>400</th> <th>420~450</th> </tr> </thead> <tbody> <tr> <td>tanδ</td> <td>0.15</td> <td>0.20</td> </tr> </tbody> </table>	Rated voltage(V)	400	420~450	tanδ	0.15	0.20
Rated voltage(V)	400	420~450					
tanδ	0.15	0.20					
Endurance	After applying rated voltage with rated Ripple current for 3000hrs at 105°C , the capacitor shall meet the following requirement. <table border="1"> <tbody> <tr> <td>Capacitance Change</td> <td>Within±20% of the initial value</td> </tr> <tr> <td>Dissipation Factor</td> <td>Not more than 200% of the specified value</td> </tr> <tr> <td>Leakage Current</td> <td>Not more than the specified value</td> </tr> </tbody> </table>	Capacitance Change	Within±20% of the initial value	Dissipation Factor	Not more than 200% of the specified value	Leakage Current	Not more than the specified value
Capacitance Change	Within±20% of the initial value						
Dissipation Factor	Not more than 200% of the specified value						
Leakage Current	Not more than the specified value						
Shelf Life	After placed at 105°C without voltage applied for 1000 hours, the capacitor shall meet the same requirements as Endurance.						

Diagram of Dimensions

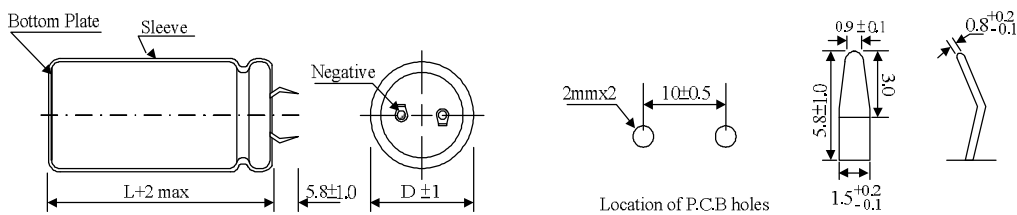

Multiplier for Ripple Current

Frequency coefficient

Freq. (Hz)	50	120	300	1K	10K	50K
400~450V	0.77	1.00	1.16	1.30	1.41	1.43

ALUMINUM ELECTROLYTIC CAPACITORS



High temperature and Smaller-size Series

■ Dimensions, Rated Ripple Current

Capacitance (μF)	Rated (Surge) Voltage					
	400 (450)		420(470)		450 (500)	
	Size	Ripple	Size	Ripple	Size	Ripple
82					22x25	0.64
100			22x25	0.70		
120	22X25	0.77	22x30	0.81	22x30	0.81
			25x25	0.81	22x35	0.83
					25x25	0.81
150	22X30	0.9	22x35	0.93	22x40	0.94
					25x30	0.93
180	22X35	1.02	22x40	1.04	22X45	1.06
	25x25	0.99	25x30	1.02	25x35	1.06
			30x25	1.06	30x25	1.06
220	22x40	1.15	22X45	1.17	22X50	1.20
	25x30	1.13	22X50	1.20	25x40	1.20
			25x35	1.18	30x30	1.18
			30x30	1.18	35x25	1.24
270	22x45	1.29	25x40	1.33	25X45	1.36
	25x35	1.30	25x45	1.36	25X50	1.38
	30x25	1.29	35x25	1.38	30x35	1.34
					35x30	1.40
330	22x50	1.47	25X50	1.52	30x40	1.52
	25x40	1.47	30x35	1.48		
	30x30	1.45	30x40	1.52		
	35X25	1.52	35x30	1.55		
390	25x45	1.63	30x45	1.70	30X45	1.70
	25x50	1.66	35x35	1.71	30X50	1.73
	30x35	1.61			35x35	1.71
470	30x40	1.82	30X50	1.90	35x40	1.95
	35x30	1.85	35x40	1.95	35x45	1.99
560	30x45	2.04	35x45	2.17	35x50	2.22
	30x50	2.07				
	35x35	2.05				
680	35x40	2.34	35x50	2.45	35x55	2.30
	35x45	2.40				
820	35x50	2.69			35x60	2.42
1000	35x60	2.75			35x65	2.77

☆ Size: D \times L (mm) ☆ Ripple Current : A/rms. 105°C, 120Hz

ALUMINUM ELECTROLYTIC CAPACITORS

LQ High temperature and long life Series

- Features : 105°C 5000 hours , Wide temperature range for LF , Longer life than HW, Snap-in terminal, High ripple current
- Recommended Applications: Smoothing circuit, TV/Monitor,Adapter, SMPS
- Corresponding product to RoHS

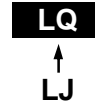

Long Life



Specifications

Item	Characteristics	
Operating Temperature Range	-25 ~ +105°C	
Rated Voltage Range	160 ~ 500VDC	
Capacitance Range	56 ~ 2200μF	
Capacitance Tolerance	± 20 % at 120Hz , 20°C	
Leakage Current (MAX) (20°C)	$I \leq 0.02CV$ or 3mA whichever is smaller(After rated voltage applied for 5 minutes) $I =$ Leakage Current (μA) $C =$ Nominal Capacitance (μF) $V =$ Rated Voltage (V)	
Dissipation Factor (MAX) (tanδ) (120Hz ,20°C)	Dissipation Factor(tanδ)shall not exceed the values showed in the table of standard rating	
Endurance	After applying rated voltage with rated Ripple current for 5000hrs at 105°C , the capacitor shall meet the following requirement.	
	Capacitance Change	Within±20% of the initial value
	Dissipation Factor	Not more than 200% of the specified value
	Leakage Current	Not more than the specified value
Shelf Life	After placed at 105°C without voltage applied for 1000 hours, the capacitor shall meet the same requirements as Endurance.	

Diagram of Dimensions

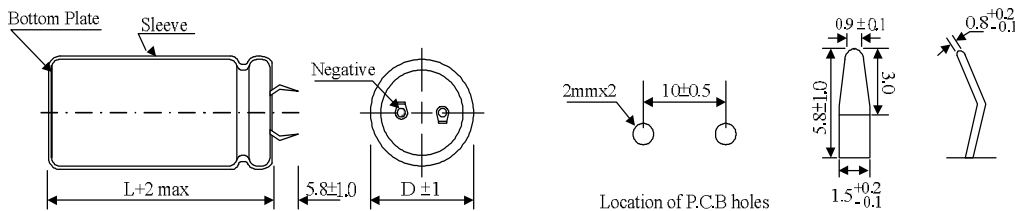

Multiplier for Ripple Current

Frequency coefficient

Freq. (Hz)	50	60	120	400	1K	2.4K	5K	10K
160~450V	0.80	0.85	1.00	1.14	1.23	1.30	1.36	1.40
500V	0.70	0.72	1.00	1.16	1.30	1.32	1.36	1.41

ALUMINUM ELECTROLYTIC CAPACITORS

LQ

High temperature and long life Series

■ Dimensions, Max Dissipation Factor, Max Permissible Ripple Current, Max Equivalent Series Resistance

Capacitance (μ F)	Rated (Surge) Voltage											
	160(200)					180(225)						
	ψ DxL				tan δ	ESR	ψ DxL				tan δ	ESR
	Ripple Current						Ripple Current					
270	22x25				0.15	0.737	22x25				0.15	0.737
	0.85						0.85					
330	22x30				0.15	0.603	22x30				0.15	0.603
	1.00						1.10					
390	22x30	25x25			0.15	0.51	22x35	25x25			0.15	0.51
	1.15	1.15					1.32	1.25				
470	22x35	25x30			0.15	0.423	22x40	25x30			0.15	0.423
	1.30	1.30					1.47	1.40				
560	22x40	25x30	30x25		0.15	0.355	22x45	25x35	30x25		0.15	0.355
	1.57	1.50	1.54				1.70	1.63	1.60			
680	22x45	25x35	30x30		0.15	0.293	22x50	25x40	30x30	35x25	0.15	0.293
	1.75	1.70	1.77				1.87	1.82	1.80	1.84		
820	22x50	25x40	30x30	35x25	0.15	0.243		25x45	30x35	35x30	0.15	0.243
	2.03	1.97	1.95	1.99				2.05	2.05	2.11		
1000		25x45	30x35	35x30	0.15	0.199		25x50	30x40	35x30	0.15	0.199
		2.15	2.15	2.21				2.27	2.29	2.25		
1200			30x40	35x35	0.15	0.166			30x45	35x35	0.15	0.166
			2.45	2.52					2.57	2.55		
1500			30x50	35x40	0.15	0.133				35x40	0.15	0.133
			2.75	2.75					2.85			
1800				35x45	0.15	0.111				35x50	0.15	0.111
				3.00					3.10			
2200				35x50	0.15	0.09						
				3.50								

Capacitance (μ F)	Rated (Surge) Voltage											
	200(250)					250(300)						
	ψ DxL				tan δ	ESR	ψ DxL				tan δ	ESR
	Ripple Current						Ripple Current					
150							22x25				0.15	1.330
							0.75					
180							22x30				0.15	1.110
							0.85					
220	22x25				0.15	0.905	22x30	25x25			0.15	0.905
	0.85						1.00	1.00				
270	22x30				0.15	0.737	22x35	25x25			0.15	0.737
	1.00						1.22	1.15				
330	22x30	25x25			0.15	0.603	22x40	25x30			0.15	0.603
	1.15	1.15					1.36	1.30				
390	22x35	25x30			0.15	0.510	22x45	25x35	30x25	35x25	0.15	0.510
	1.30	1.30					1.54	1.48	1.45	1.59		
470	22x40	25x35	30x25		0.15	0.423	22x50	25x40	30x30	35x30	0.15	0.423
	1.52	1.54	1.49				1.78	1.75	1.72	1.88		
560	22x45	25x35	30x30		0.15	0.355		25x40	30x35	35x30	0.15	0.355
	1.7	1.65	1.72					1.80	1.89	1.94		
680		25x45	30x35	35x30	0.15	0.293		25x50	30x40	35x35	0.15	0.293
		1.97	1.97	2.02				2.10	2.10	2.18		
820		25x45	30x35	35x30	0.15	0.243			30x45	35x40	0.15	0.243
		2.20	2.10	2.16					2.30	2.39		
1000			30x45	35x35	0.15	0.199			30x50	35x45	0.15	0.199
			2.32	2.30					2.55	2.65		
1200			30x50	35x40	0.15	0.166				35x50	0.15	0.166
			2.75	2.75					2.90			
1500				35x45	0.15	0.133						
				2.90								

☆Size: ψ x L(mm). ☆tan δ : 20°C, 120Hz. ☆Ripple Current: 105°C, 120Hz, (A/rms) ☆ESR: 20°C, 120Hz, (Ω).

ALUMINUM ELECTROLYTIC CAPACITORS

LQ

High temperature and long life Series

■ Dimensions, Max Dissipation Factor, Max Permissible Ripple Current, Max Equivalent Series Resistance

Capacitance (μ F)	Rated (Surge) Voltage											
	315(365)						350(400)					
	ψ DxL				tan δ	ESR	ψ DxL				tan δ	ESR
	Ripple Current						Ripple Current					
82	22x25				0.15	2.426	22x25				0.15	2.426
	0.55						0.60					
100	22x30				0.15	1.989	22x30	25x25			0.15	1.989
	0.65						0.70	0.70				
120	22x30	25x25			0.15	1.658	22x35	25x30			0.15	1.658
	0.75	0.75					0.80	0.80				
150	22x35	25x30			0.15	1.326	22x40	25x35	30x25		0.15	1.326
	0.8	0.80					0.86	0.87	0.85			
180	22x40	25x35	30x25		0.15	1.105	22x45	25x40	30x30		0.15	1.105
	1.01	1.02	1.00				1.05	1.07	1.05			
220	22x45	25x40	30x30		0.15	0.905	22x50	25x45	30x35	35x25	0.15	0.905
	1.10	1.12	1.10				1.16	1.20	1.18	1.15		
270		25x45	30x35		0.15	0.737		25x50	30x40	35x30	0.15	0.737
		1.25	1.25					1.31	1.33	1.3		
330		25x50	30x40	35x30	0.15	0.603			30x45	35x35	0.15	0.603
		1.53	1.53	1.50					1.46	1.45		
390			30x45	35x30	0.15	0.510			30x50	35x40	0.15	0.510
			1.71	1.60					1.65	1.65		
470			30x50	35x35	0.15	0.423				35x45	0.15	0.423
			1.85	1.75					1.85			
560				35x40	0.15	0.355				35x50	0.15	0.355
				2.00					2.10			
680				35x45	0.15	0.293						
				2.20								

Capacitance (μ F)	Rated (Surge) Voltage											
	400(450)						450(500)					
	ψ DxL				tan δ	ESR	ψ DxL				tan δ	ESR
	Ripple Current						Ripple Current					
56							22x25				0.25	5.921
							0.55					
68	22x25				0.15	2.926	22x30				0.25	4.876
	0.55						0.65					
82	22x30	25x25			0.15	2.426	22x35	25x25			0.25	4.044
	0.65	0.65					0.80	0.75				
100	22x35	25x25			0.15	1.989	22x40	25x30			0.25	3.316
	0.79	0.75					0.89	0.85				
120	22x40	25x30	30x25		0.15	1.658	22x45	25x35	30x25		0.25	2.763
	0.89	0.85	0.87				0.95	0.92	0.90			
150	22x45	25x35	30x30	35x25	0.15	1.326	22x50	25x40	30x30		0.25	2.210
	0.93	0.90	0.94	0.96			1.14	1.11	1.10			
180	22x50	25x40	30x30	35x25	0.15	1.105		25x45	30x35	35x25	0.25	1.842
	1.14	1.11	1.10	1.12				1.25	1.24	1.20		
220		25x45	30x35	35x30	0.15	0.905		25x50	30x40	35x30	0.25	1.507
		1.20	1.20	1.24				1.36	1.38	1.35		
270		25x50	30x40	35x30	0.15	0.737			30x45	35x35	0.25	1.228
		1.36	1.38	1.35					1.51	1.50		
330			30x45	35x35	0.15	0.603			30x50	35x40	0.25	1.005
			1.51	1.50					1.70	1.70		
390			30x50	35x40	0.15	0.510				35x45	0.25	0.850
			1.70	1.70					1.90			
470				35x45	0.15	0.423				35x50	0.25	0.705
				1.90					2.10			

☆Size: D \times L(mm). ☆tan δ : 20 $^{\circ}$ C, 120Hz. ☆Ripple Current: 105 $^{\circ}$ C, 120Hz, (A/rms) ☆ESR: 20 $^{\circ}$ C, 120Hz, (Ω).

ALUMINUM ELECTROLYTIC CAPACITORS

LQ

■ Dimensions, Max Dissipation Factor, Max Permissible Ripple Current, Max Equivalent Series Resistance

Capacitance (μF)	Rated (Surge) Voltage				
	500 (550)				
	$\psi\text{D}\times\text{L}$			tan δ	ESR
	Ripple Current				
100	30x25			0.25	3.316
	0.82				
120		30x30	35x25	0.25	2.763
		0.91	0.88		
150		30x35		0.25	2.210
		1.04			
180		30x40	35x30	0.25	1.842
		1.17	1.10		
220		30x45	35x35	0.25	1.507
		1.33	1.23		
270		30x50	35x40	0.25	1.228
		1.50	1.42		
330			35x45	0.25	1.005
			1.60		
390			35x50	0.25	0.850
			1.78		
470			35x60	0.25	0.705
			2.03		

☆Size: D ϕ x L (mm). ☆tan δ : 20°C, 120Hz. ☆Ripple Current: 105°C, 120Hz, (A/rms) ☆ESR: 20°C, 120Hz, (Ω).

ALUMINUM ELECTROLYTIC CAPACITORS

LK High temperature and long life Series

- Features : 105°C 7000 hours , Longer life than LQ, Snap-in terminal, High ripple current
- Recommended Applications: Smoothing circuit, TV/Monitor, Adapter, SMPS
- Corresponding product to RoHS

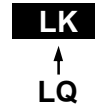

Long Life



Specifications

Item	Characteristics						
Operating Temperature Range	-25 ~ +105°C						
Rated Voltage Range	160 ~ 450VDC						
Capacitance Range	39 ~ 2200µF						
Capacitance Tolerance	± 20 % at 120Hz , 20°C						
Leakage Current (MAX) (20°C)	$I \leq 0.02CV$ or 3mA whichever is smaller (After rated voltage applied for 5 minutes) I = Leakage Current (µA) C = Nominal Capacitance (µF) V = Rated Voltage (V)						
Dissipation Factor (MAX) (tanδ) (120Hz , 20°C)	Dissipation Factor(tanδ) shall not exceed the values showed in the table of standard rating						
Endurance	After applying rated voltage with rated Ripple current for 7000hrs at 105°C , the capacitor shall meet the following requirement.						
	<table border="1"> <tr> <td>Capacitance Change</td> <td>Within ±20% of the initial value</td> </tr> <tr> <td>Dissipation Factor</td> <td>Not more than 200% of the specified value</td> </tr> <tr> <td>Leakage Current</td> <td>Not more than the specified value</td> </tr> </table>	Capacitance Change	Within ±20% of the initial value	Dissipation Factor	Not more than 200% of the specified value	Leakage Current	Not more than the specified value
	Capacitance Change	Within ±20% of the initial value					
Dissipation Factor	Not more than 200% of the specified value						
Leakage Current	Not more than the specified value						
Shelf Life	After placed at 105°C without voltage applied for 1000 hours, the capacitor shall meet the same requirements as Endurance.						

Diagram of Dimensions

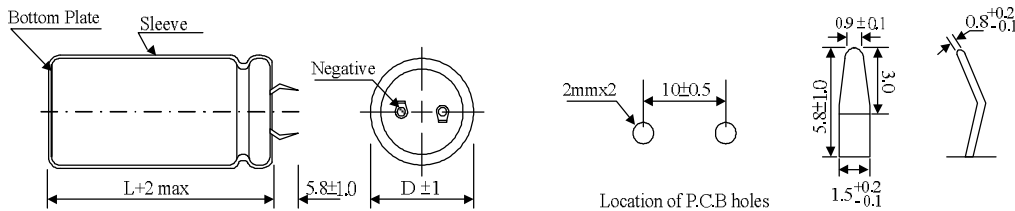

Multiplier for Ripple Current

Frequency coefficient

Freq. (Hz)		60(50)	120	500	1K	≥ 10K
Coefficient	160~250WV	0.80	1.00	1.20	1.30	1.50
	315~450WV	0.80	1.00	1.20	1.25	1.40

ALUMINUM ELECTROLYTIC CAPACITORS



High temperature and long life Series

■ Dimensions, Max Dissipation Factor, Max Permissible Ripple Current, Max Equivalent Series Resistance

Capacitance (μF)	Rated (Surge) Voltage									
	160(200)				tanδ	180(225)				tanδ
	ψDxL					ψDxL				
	Ripple Current					Ripple Current				
220						22x25				
						1.00				
270	22x25				0.15	22x25				0.15
	1.10					1.10				
330	22x25				0.15	22x30	25x25			0.15
	1.20					1.20	1.20			
390	22x30	25x25			0.15	22x30	25x25			0.15
	1.30	1.30				1.30	1.30			
470	22x35	25x30			0.15	22x35	25x30	30x25		0.15
	1.40	1.40				1.40	1.40	1.40		
560	22x40	25x30	30x25		0.15	22x40	25x35	30x25		0.15
	1.50	1.50	1.50			1.50	1.50	1.50		
680	22x45	25x35	30x30		0.15	22x45	25x35	30x30		0.15
	1.70	1.70	1.70			1.70	1.70	1.70		
820	22x50	25x40	30x30		0.15		25x40	30x35	35x30	0.15
	2.00	2.00	2.00				2.00	2.00	2.00	
1000		25x45	30x35	35x30	0.15		25x50	30x35	35x30	0.15
		2.20	2.20	2.20			2.20	2.20	2.20	
1200		25x50	30x40	35x35	0.15			30x40	35x35	0.15
		2.40	2.42	2.43				2.40	2.40	
1500			30x45	35x35	0.15			30x50	35x40	0.15
			2.70	2.70				2.70	2.70	
1800			30x50	35x40	0.15				35x45	0.15
			2.90	2.90					2.90	
2200				35x45	0.15				35x50	0.15
				3.10					3.10	

Capacitance (μF)	Rated (Surge) Voltage									
	200(250)				tanδ	250(300)				tanδ
	ψDxL					ψDxL				
	Ripple Current					Ripple Current				
180						22x25	25x25			0.15
						0.90	0.90			
220	22x25				0.15	22x30	25x25			0.15
	1.00					1.00	1.00			
270	22x30	25x25			0.15	22x35	25x30	30x25		0.15
	1.10	1.10				1.10	1.10	1.10		
330	22x30	25x25			0.15	22x40	25x30	30x25		0.15
	1.20	1.20				1.20	1.20	1.20		
390	22x35	25x30	30x25		0.15	22x45	25x35	30x30		0.15
	1.30	1.30	1.30			1.30	1.30	1.30		
470	22x40	25x35	30x25		0.15	22x50	25x40	30x30	35x30	0.15
	1.40	1.40	1.40			1.40	1.40	1.40	1.43	
560	22x45	25x35	30x30		0.15		25x45	30x35	35x30	0.15
	1.55	1.53	1.53				1.60	1.60	1.60	
680	22x50	25x40	30x30		0.15		25x50	30x40	35x35	0.15
	1.73	1.75	1.73				1.80	1.83	1.83	
820		25x45	30x35	35x30	0.15			30x45	35x35	0.15
		2.00	2.00	2.00				2.10	2.05	
1000			30x40	35x35	0.15			30x50	35x40	0.15
			2.20	2.30				2.30	2.30	
1200			30x45	35x40	0.15				35x45	0.15
			2.40	2.45					2.40	
1500				35x50	0.15					
				2.70						

☆Size: Dψx L(mm). ☆tanδ: 20°C, 120Hz. ☆Ripple Current: 105°C, 120Hz, (A/rms)

ALUMINUM ELECTROLYTIC CAPACITORS

LK High temperature and long life Series

■ Dimensions, Max Dissipation Factor, Max Permissible Ripple Current, Max Equivalent Series Resistance

Capacitance (μF)	Rated (Surge) Voltage									
	315(365)				tanδ	350(400)				tanδ
	ψDxL Ripple Current					ψDxL Ripple Current				
82	22x25				0.20	22x25				0.20
	0.64					0.64				
100	22x30				0.20	22x30	25x25			0.20
	0.69					0.69	0.69			
120	22x30	25x25			0.20	22x35	25x30			0.20
	0.75	0.75				0.75	0.75			
150	22x35	25x30	30x25		0.20	22x40	25x30	30x25		0.20
	0.82	0.82	0.82			0.85	0.85	0.85		
180	22x40	25x30	30x25		0.20	22x45	25x35	30x30		0.20
	0.9	0.90	0.90			0.95	0.95	0.95		
220	22x45	25x35	30x30		0.20	22x50	25x40	30x30		0.20
	1.05	1.05	1.05			1.05	1.05	1.05		
270		25x40	30x35	35x30	0.20		25x45	30x35	35x30	0.20
		1.20	1.20	1.20			1.20	1.21	1.21	
330		25x50	30x40	35x30	0.20			30x40	35x35	0.20
		1.35	1.35	1.35				1.35	1.35	
390			30x40	35x35	0.20			30x45	35x35	0.20
			1.50	1.50				1.45	1.45	
470			30x45	35x40	0.20			30x50	35x40	0.20
			1.60	1.60				1.55	1.55	
560				35x45	0.20				35x50	0.20
				1.70					1.70	
680				35x50	0.20					
				1.90						

Capacitance (μF)	Rated (Surge) Voltage									
	400(450)				tanδ	450(500)				tanδ
	ψDxL Ripple Current					ψDxL Ripple Current				
39						22x25				0.20
						0.40				
47						22x30				0.20
						0.46				
56	22x25				0.20	22x35	25x25			0.20
	0.51					0.52	0.52			
68	22x30	25x25			0.20	22x40	25x30			0.20
	0.56	0.56				0.58	0.58			
82	22x30	25x25			0.20	22x45	25x35	30x25		0.20
	0.64	0.64				0.65	0.65	0.65		
100	22x35	25x30			0.20	22x50	25x40	30x30		0.20
	0.69	0.69				0.73	0.73	0.73		
120	22x40	25x30	30x25		0.20		25x45	30x30		0.20
	0.75	0.75	0.75				0.82	0.82		
150	22x45	25x35	30x30		0.20		25x50	30x40	35x30	0.20
	0.82	0.82	0.82				0.96	0.96	0.96	
180	22x50	25x40	30x30	35x25	0.20			30x45	35x35	0.20
	0.93	0.93	0.95	0.95				1.07	1.07	
220		25x45	30x35	35x30	0.20			30x50	35x40	0.20
		1.03	1.03	1.02				1.21	1.21	
270			30x40	35x35	0.20				35x45	0.20
			1.21	1.20					1.40	
330			30x45	35x40	0.20				35x50	0.20
			1.40	1.38					1.60	
390				35x45	0.20					
				1.50						
470				35x50	0.20					
				1.60						

☆Size: Dψx L(mm). ☆tanδ: 20°C, 120Hz. ☆Ripple Current: 105°C, 120Hz, (A/rms)