

HEX INVERTER

The TC74AC04 is an advanced high speed CMOS INVERTER fabricated with silicon gate and double - layer metal wiring C²MOS technology.

It achieves the high speed operation similar to equivalent Bipolar Schottky TTL while maintaining the CMOS low power dissipation.

The internal circuit is composed of 3 stages including buffer output, which provide high noise immunity and stable output. All inputs are equipped with protection circuits against static discharge or transient excess voltage.

FEATURES :

- High Speed..... $t_{pd} = 3.2ns$ (typ.) at $V_{CC} = 5V$
- Low Power Dissipation..... $I_{CC} = 4\mu A$ (Max.) at $T_a = 25^\circ C$
- High Noise Immunity..... $V_{NIH} = V_{NIL} = 28\% V_{CC}$ (Min.)
- Symmetrical Output Impedance... $|I_{OH}| = I_{OL} = 24mA$ (Min.)
 Capability of driving 50 Ω transmission lines.
- Balanced Propagation Delays.... $t_{PLH} \approx t_{PHL}$
- Wide Operating Voltage Range.... V_{CC} (opr) = 2V ~ 5.5V
- Pin and Function Compatible with 74F04

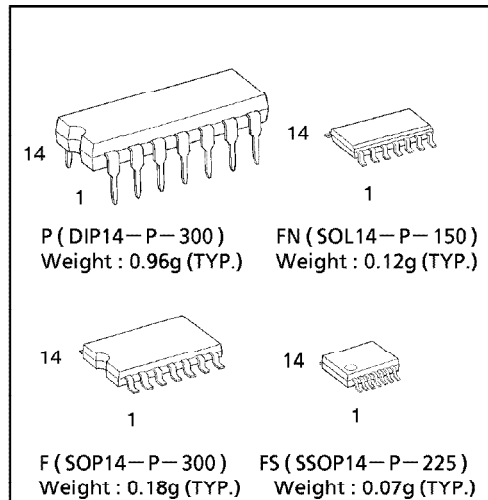

PIN ASSIGNMENT

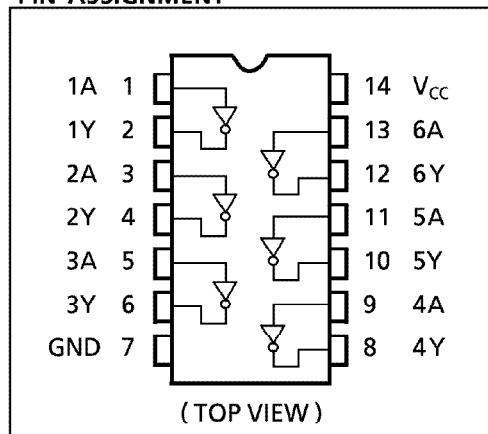

IEC LOGIC SYMBOL

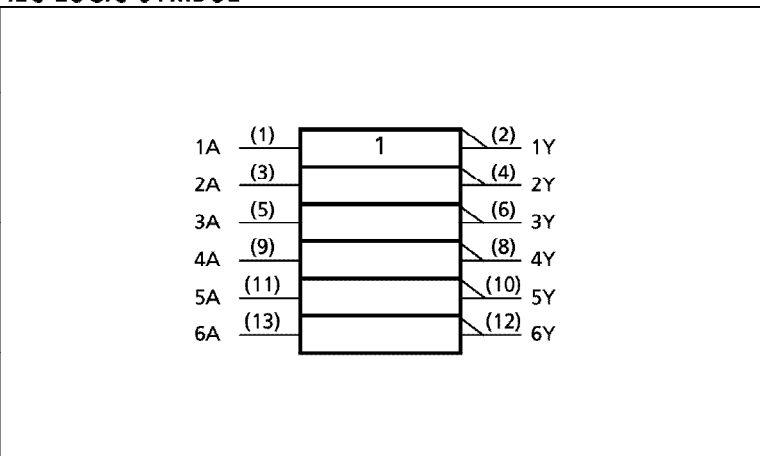

TRUTH TABLE

A	Y
L	H
H	L

© The information contained herein is presented only as a guide for the applications of our products. No responsibility is assumed by TOSHIBA CORPORATION for any infringements of intellectual property or other rights of the third parties which may result from its use. No license is granted by implication or otherwise under any intellectual property or other rights of TOSHIBA CORPORATION or others.
 © These TOSHIBA products are intended for use in general commercial applications (office equipment, communication equipment, measuring equipment, domestic appliances, etc.) please make sure that you consult with us before you use these TOSHIBA products in equipment which requires extraordinarily high quality and/or reliability, and in equipment which may involve life threatening or critical application, including but not limited to such uses as atomic energy control, airplane or spaceship instrumentation, traffic signals, medical instrumentation, combustion control, all types of safety devices, etc. TOSHIBA cannot accept and hereby disclaims liability for any damage which may occur in case the TOSHIBA products are used in such equipment or applications without prior consultation with TOSHIBA.

ABSOLUTE MAXIMUM RATINGS

PARAMETER	SYMBOL	VALUE	UNIT
Supply Voltage Range	V_{CC}	-0.5~7.0	V
DC Input Voltage	V_{IN}	-0.5~ $V_{CC} + 0.5$	V
DC Output Voltage	V_{OUT}	-0.5~ $V_{CC} + 0.5$	V
Input Diode Current	I_{IK}	± 20	mA
Output Diode Current	I_{OK}	± 50	mA
DC Output Current	I_{OUT}	± 50	mA
DC V_{CC} /Ground Current	I_{CC}	± 150	mA
Power Dissipation	P_D	500 (DIP)* / 180 (SOP/SSOP)	mW
Storage Temperature	T_{stg}	-65~150	°C

*500mW in the range of $T_a = -40^{\circ}\text{C} \sim 65^{\circ}\text{C}$. From $T_a = 65^{\circ}\text{C}$ to 85°C a derating factor of $-10\text{mW}/^{\circ}\text{C}$ should be applied up to 300mW.

RECOMMENDED OPERATING CONDITIONS

PARAMETER	SYMBOL	VALUE	UNIT
Supply Voltage	V_{CC}	2.0~5.5	V
Input Voltage	V_{IN}	0~ V_{CC}	V
Output Voltage	V_{OUT}	0~ V_{CC}	V
Operating Temperature	T_{opr}	-40~85	°C
Input Rise and Fall Time	dt / dV	0~ 100 ($V_{CC} = 3.3 \pm 0.3\text{V}$) 0~ 20 ($V_{CC} = 5 \pm 0.5\text{V}$)	ns / V

DC ELECTRICAL CHARACTERISTICS

PARAMETER	SYMBOL	TEST CONDITION	V_{CC} (V)	$T_a = 25^{\circ}\text{C}$			$T_a = -40 \sim 85^{\circ}\text{C}$		UNIT	
				MIN.	TYP.	MAX.	MIN.	MAX.		
High - Level Input Voltage	V_{IH}		2.0	1.50	—	—	1.50	—	V	
			3.0	2.10	—	—	2.10	—		
			5.5	3.85	—	—	3.85	—		
Low - Level Input Voltage	V_{IL}		2.0	—	—	0.50	—	0.50	V	
			3.0	—	—	0.90	—	0.90		
			5.5	—	—	1.65	—	1.65		
High - Level Output Voltage	V_{OH}	$V_{IN} = V_{IL}$	$I_{OH} = -50\mu\text{A}$	2.0	1.9	2.0	—	1.9	—	V
				3.0	2.9	3.0	—	2.9	—	
				4.5	4.4	4.5	—	4.4	—	
				3.0	2.58	—	—	2.48	—	
Low - Level Output Voltage	V_{OL}	$V_{IN} = V_{IH}$	$I_{OL} = 50\mu\text{A}$	3.0	3.94	—	—	3.80	—	V
				4.5	—	—	—	3.85	—	
				5.5	—	—	—	—	—	
				3.0	—	—	0.36	—	0.44	
Low - Level Output Voltage	V_{OL}	$V_{IN} = V_{IH}$	$I_{OL} = 24\text{mA}$	4.5	—	—	0.36	—	0.44	V
				5.5	—	—	—	—	1.65	
				3.0	—	—	—	—	—	
				4.5	—	—	—	—	—	
Input Leakage Current	I_{IN}	$V_{IN} = V_{CC}$ or GND	5.5	—	—	± 0.1	—	± 1.0	μA	
Quiescent Supply Current	I_{CC}	$V_{IN} = V_{CC}$ or GND	5.5	—	—	4.0	—	40.0		

* : This spec indicates the capability of driving 50Ω transmission lines.
One output should be tested at a time for a 10ms maximum duration.

AC ELECTRICAL CHARACTERISTICS ($C_L = 50\text{pF}$, $R_L = 500\ \Omega$, Input $t_r = t_f = 3\text{ns}$)

PARAMETER	SYMBOL	TEST CONDITION	Ta = 25°C			Ta = -40~85°C		UNIT	
			V _{CC} (V)	MIN.	TYP.	MAX.	MIN.		MAX.
Propagation Delay Time	t _{pLH} t _{pHL}		3.3 ± 0.3	—	5.7	9.8	1.0	11.2	ns
			5.0 ± 0.5	—	4.3	6.6	1.0	7.5	
Input Capacitance	C _{IN}		—	5	10	—	10	pF	
Power Dissipation Capacitance	C _{PD} (1)		—	20	—	—	—		

Note (1) C_{PD} is defined as the value of the internal equivalent capacitance which is calculated from the operating current consumption without load.

Average operating current can be obtained by the equation :

$$I_{CC}(\text{opr.}) = C_{PD} \cdot V_{CC} \cdot f_{IN} + I_{CC} / 6 \text{ (per Gate)}$$

DIP 14PIN OUTLINE DRAWING (DIP14-P-300)

Unit in mm

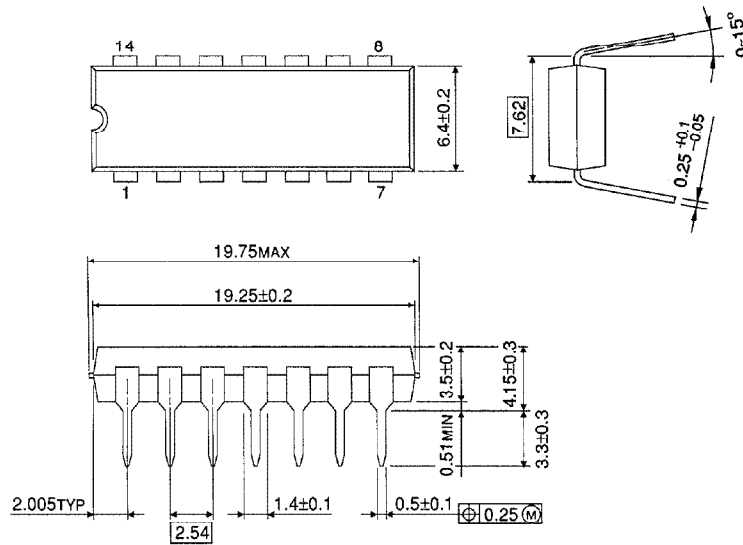

Weight: 0.96g (TYP.)

SOP 14PIN (200mil BODY) OUTLINE DRAWING (SOP14-P-300)

Unit in mm

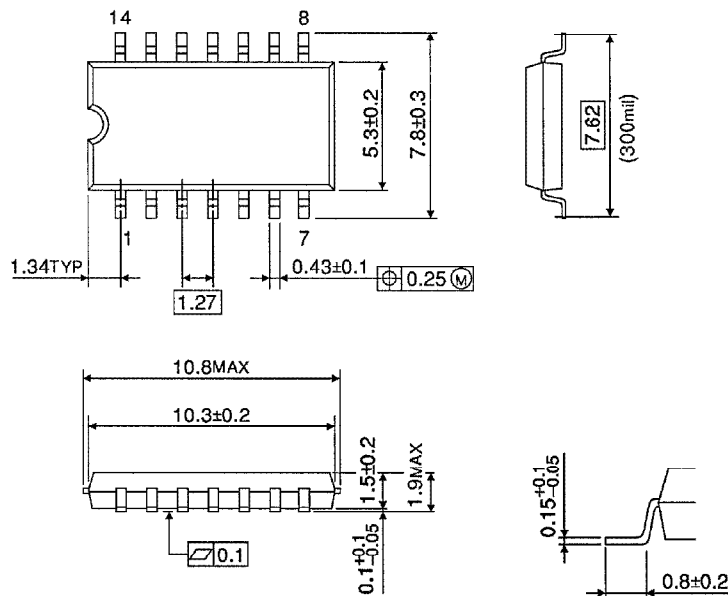

Weight: 0.18g (TYP.)

SOP 14PIN (150mil BODY) OUTLINE DRAWING (SOL14-P-150)

Unit in mm

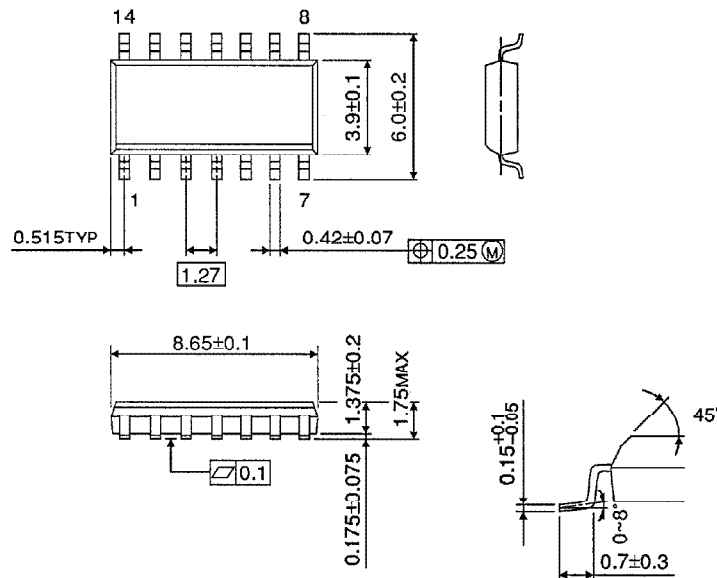

Weight : 0.12g (TYP.)

SSOP 14PIN OUTLINE DRAWING (SSOP14-P-225)

Unit in mm

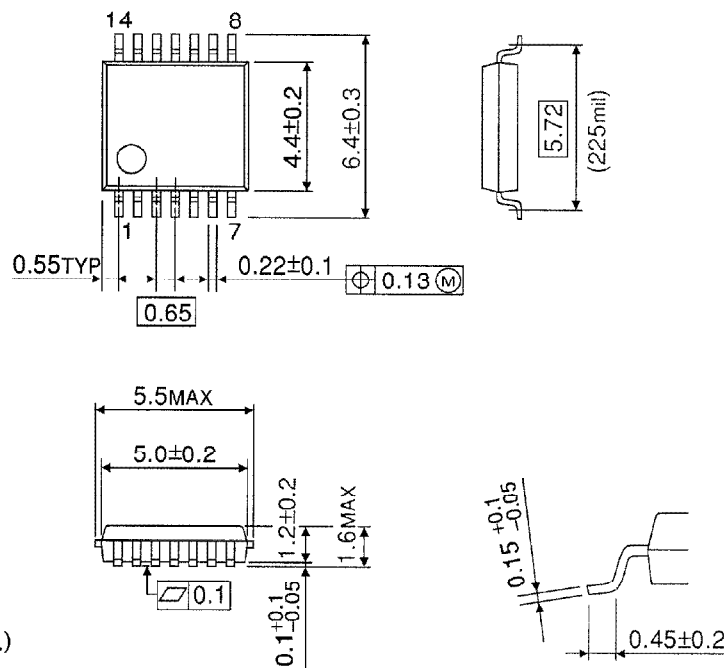

Weight : 0.07g (TYP.)