

1 MEGA BIT (65,536 WORD × 16 BIT)
 CMOS U.V. ERASABLE AND ELECTRICALLY PROGRAMMABLE READ ONLY MEMORY

DESCRIPTION

The TC57H1024AD is a 65,536 word × 16 bit CMOS ultraviolet light erasable and electrically programmable read only memory. The TC57H1024AD is JEDEC standard pin configuration. This product is packed in 40 pin standard cerdip package.

TC57H1024AD is fabricated with the CMOS technology. Advanced circuit techniques provide both high speed and low power features with a maximum operating current of 40mA/1MHz and access time of 85ns/100ns.

The programming times of the TC57H1024AD except overhead times of EPROM programmer is only 7 seconds by using the high speed programming algorithm.

FEATURES

- Peripheral circuit : CMOS
- Single 5V power supply
- Memory cell : NMOS
- Full static operation
- Fast access time
- High speed programming operation : tpw 0.1ms
- TC57H1024AD-85 : 85ns
- Input and output TTL compatible
- TC57H1024AD-100 : 100ns
- JEDEC standard 40 pin
- Low power dissipation
- Active : 40mA/1MHz
- Standby : 100µA
- Standard 40 pin DIP cerdip package
- : WDIP40-G-600A

PIN CONNECTION (TOP VIEW)

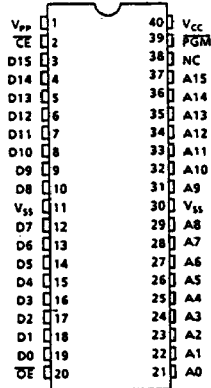

PIN NAMES

A0~A15	Address Inputs
D0~D15	Outputs (Inputs)
CE	Chip Enable Input
OE	Output Enable Input
PGM	Program Control Input
Vcc	Vcc Supply Voltage
Vpp	Program Supply Voltage
Vss	Ground
NC	No Connection

TC57H1024AD-85,100

BLOCK DIAGRAM

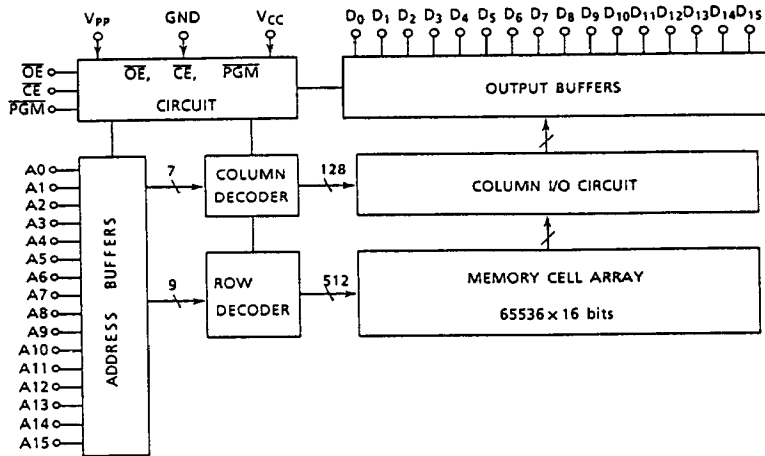

MODE SELECTION

MODE \ PIN	\overline{CE}	\overline{OE}	PGM	V_{PP}	V_{CC}	D0-D15	Power
Read	L	L	H	5V	5V	Data Out	Active
Output Deselect	*	H	*			High Impedance	
Standby	H	*	*			High Impedance	Standby
Program	L	H	L	12.75V	6.25V	Data In	Active
Program Inhibit	H	*	*			High Impedance	
Program Verify	L	H	H			Data Out	

* H or L

MAXIMUM RATINGS

SYMBOL	ITEM	RATING	UNIT
V_{CC}	V_{CC} Power Supply Voltage	-0.6~7.0	V
V_{PP}	Program Supply Voltage	-0.6~14.0	V
V_{IN}	Input Voltage	-0.6~7.0	V
$V_{IN}(A9)$	Input Voltage (A9)	-0.6~13.5	V
V_{IO}	Input/Output Voltage	-0.6~ $V_{CC} + 0.5$	V
P_D	Power Dissipation	1.5	W
T_{SOLDER}	Soldering Temperature Time	260 · 10	°C · sec
T_{STG}	Storage Temperature	-65~125	°C
T_{OPR}	Operating Temperature	0~70	°C

READ OPERATION

AC/DC RECOMMENDED OPERATING CONDITIONS

SYMBOL	PARAMETER	TC57H1024D-85	TC57H1024D-100
T _a	Ambient Temperature	0~70°C	
V _{CC}	V _{CC} Power Supply Voltage	5V ± 5%	5V ± 10%
V _{PP}	V _{PP} Power Supply Voltage	0V~V _{CC} +0.6V	

DC AND OPERATING CHARACTERISTICS

SYMBOL	PARAMETER	TEST CONDITION	MIN.	TYP.	MAX.	UNIT
I _{LI}	Input Current	V _{IN} = 0~V _{CC}	-	-	± 10	μA
I _{CCO}	Operating Current	CE = 0V I _{OUT} = 0mA	-	-	60	mA
		tcycle = 85ns tcycle = 1μs	-	-	40	mA
I _{CCS1}	Standby Current	CE = V _{IH}	-	-	1	mA
I _{CCS2}		CE = V _{CC} - 0.2V	-	-	100	μA
V _{IH}	Input High Voltage	—	2.2	-	V _{CC} + 0.3	V
V _{IL}	Input Low Voltage	—	- 0.3	-	0.8	V
V _{OH}	Output High Voltage	I _{OH} = - 400μA	2.4	-	-	V
V _{OL}	Output Low Voltage	I _{OL} = 2.1mA	-	-	0.4	V
I _{PP1}	V _{PP} Current	V _{PP} = 0V~V _{CC} +0.6V	-	-	± 10	μA
I _{LO}	Output Leakage Current	V _{OUT} = 0.4V~V _{CC}	-	-	± 10	μA

AC CHARACTERISTICS (V_{PP} = 0V~V_{CC}+0.6V)

SYMBOL	PARAMETER	TC57H1024AD-85		TC57H1024AD-100		UNIT
		MIN.	MAX.	MIN.	MAX.	
t _{ACC}	Address Access Time	-	85	-	100	ns
t _{CE}	CE to Output Valid	-	85	-	100	
t _{OE}	OE to Output Valid	-	45	-	50	
t _{DF1}	CE to Output in High-Z	-	30	-	50	
t _{DF2}	OE to Output in High-Z	-	30	-	50	
t _{OH}	Output Data Hold Time	5	-	10	-	

TC57H1024AD-85 are satisfied with the specification of TC57H1024AD-100

AC TEST CONDITIONS

- Output Load : 1 TTL Gate and C_L = 100pF
- Input Pulse Rise and Fall Times : 10ns Max.
- Input Pulse Levels : 0.45V to 2.4V
- Timing Measurement Reference Levels: Inputs 0.8V and 2.2V Outputs 0.8V and 2.0V

CAPACITANCE *($T_a = 25^\circ\text{C}$, $f = 1\text{MHz}$)

SYMBOL	PARAMETER	TEST CONDITION	MIN.	MAX.	UNIT
C_{IN}	Input Capacitance	$V_{IN} = 0V$	-	16	pF
C_{OUT}	Output Capacitance	$V_{OUT} = 0V$	-	16	

* This parameter is periodically sampled and is not 100% tested.

TIMING WAVEFORMS (READ)

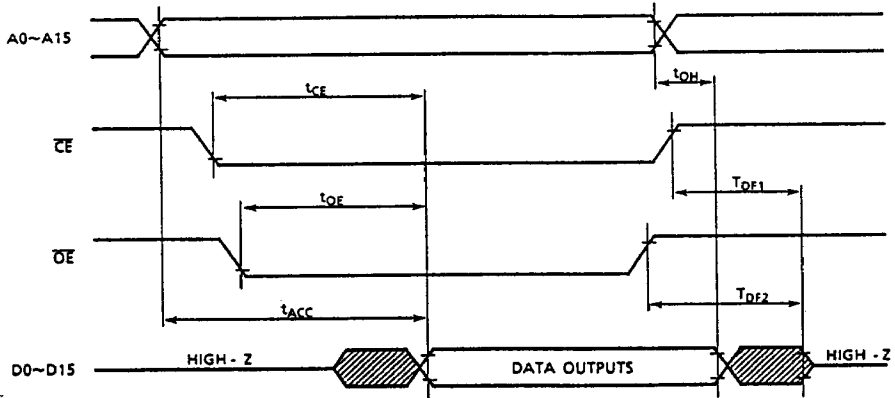

HIGH SPEED PROGRAM OPERATION

DC RECOMMENDED OPERATING CONDITIONS

SYMBOL	PARAMETER	MIN.	TYP.	MAX.	UNIT
V _{IH}	Input High Voltage	2.2	-	V _{CC} + 0.3	V
V _{IL}	Input Low Voltage	-0.3	-	0.8	V
V _{CC}	V _{CC} Power Supply Voltage	6.00	6.25	6.50	V
V _{PP}	V _{PP} Power Supply Voltage	12.50	12.75	13.00	V

DC AND OPERATING CHARACTERISTICS (T_a = 25 ± 5°C, V_{CC} = 6.25V ± 0.25V, V_{PP} = 12.75V ± 0.25V)

SYMBOL	PARAMETER	TEST CONDITION	MIN.	TYP.	MAX.	UNIT
I _{LI}	Input Current	V _{IH} = 0 ~ V _{CC}	-	-	± 10	μA
V _{OH}	Output High Voltage	I _{OH} = - 400μA	2.4	-	-	V
V _{OL}	Output Low Voltage	I _{OL} = 2.1mA	-	-	0.4	V
I _{CC}	V _{CC} Supply Current	-	-	-	50	mA
I _{PP2}	V _{PP} Supply Current	V _{PP} = 13.0V	-	-	100	mA

AC PROGRAMMING CHARACTERISTICS (T_a = 25 ± 5°C, V_{CC} = 6.25V ± 0.25V, V_{PP} = 12.75V ± 0.25V)

SYMBOL	PARAMETER	TEST CONDITION	MIN.	TYP.	MAX.	UNIT
t _{AS}	Address Setup Time	-	2	-	-	μs
t _{AH}	Address Hold Time	-	2	-	-	μs
t _{CEs}	\overline{CE} Setup Time	-	2	-	-	μs
t _{CEH}	\overline{CE} Hold Time	-	2	-	-	μs
t _{Ds}	Data Setup Time	-	2	-	-	μs
t _{DH}	Data Hold Time	-	2	-	-	μs
t _{Vs}	V _{PP} Setup Time	-	2	-	-	μs
t _{PW}	Program Pulse Width	-	0.095	0.1	0.105	ms
t _{OE}	\overline{OE} to Output Valid	-	-	-	500	ns
t _{DF2}	\overline{OE} to Output in High-Z	$\overline{CE} = V_{IL}$	-	-	150	ns
t _{OES}	\overline{OE} Setup Time	-	2	-	-	μs

AC TEST CONDITIONS

- Output Load : 1 TTL Gate and CL = 100pF
- Input Pulse Rise and Fall Times : 10ns Max.
- Input Pulse Levels : 0.45V and 2.4V
- Timing Measurement Reference Levels: Inputs 0.8V and 2.2V, Outputs 0.8V and 2.0V

HIGH SPEED PROGRAM OPERATION

TIMING CHART

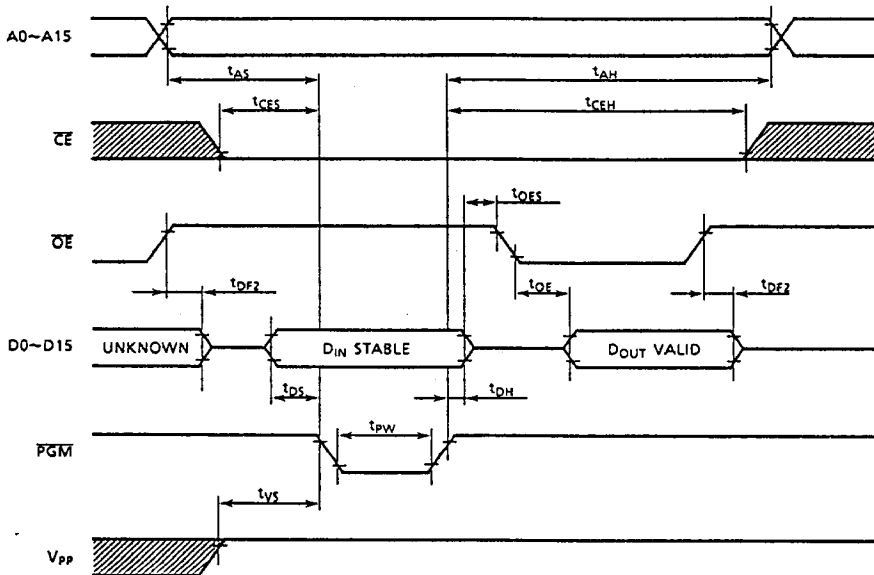

- Note :
1. V_{CC} must be applied simultaneously or before V_{PP} and cut off simultaneously or after V_{PP}.
 2. Removing the device from socket and setting the device in socket with V_{PP}=12.75V may cause permanent damage to the device.
 3. The V_{PP} supply voltage is permitted up to 14V for program operation, so the voltage over 14V should not be applied to the V_{PP} terminal.
When the switching pulse voltage is applied to the V_{PP} terminal, the overshoot voltage of its pulse should not be exceeded 14V.

ERASURE CHARACTERISTICS

The TC57H1024AD's erasure is achieved by applying shortwave ultraviolet light which has a wavelength of 2537Å (Angstroms) to the chip through the transparent window. Then integrated dose (Ultraviolet light intensity [W/cm²] × exposure time [sec.]) for erasure should be a minimum of 15 [W·sec./cm²].

When the Toshiba sterilizing lamp GL-15 is used and the device is exposed at a distance of 1cm from the lamp surface, the erasure will be achieved within 60 minutes. And using commercial lamps whose ultraviolet light intensity is a 12000 [µW/cm²] will reduce the exposure time to about 20 minutes. (In this case, the integrated dose is 12000 [µW/cm²] × (20 × 60) [sec.] ≈ 15 [W·sec./cm²].)

The TC57H1024AD's erasure begins to occur when exposed to light with wavelength shorter than 4000Å. The sunlight and the flourescent lamps will include 3000~4000Å wavelength components. Therefore when used under such lighting for extended periods of time, the opeque seals - Toshiba EPROM Protect Seal AC901 - are available.

OPERATION INFORMATION

The TC57H1024AD's six operation modes are listed in the following table.

Mode selection can be achieved by applying TTL level signal to all inputs.

MODE	PIN	CE	OE	PGM	V _{pp}	V _{cc}	D0~D15	Power
READ OPERATION	Read	L	L	H	5V	5V	Data Out	Active
	Output Deselect	*	H	*			High Impedance	
	Standby	H	*	*			Standby	
PROGRAM OPERATION (T _a = 25 ± 5°C)	Program	L	H	L	12.75V	6.25V	Data In	Active
	Program Inhibit	H	*	*			High Impedance	
		L	H	H				
	Program Verify	L	L	H			Data Out	

Note : H : V_{IH}, L : V_{IL}, * : V_{IH} or V_{IL}

READ MODE

The TC57H1024AD has three control functions. The chip enable (\overline{CE}) controls the operation power and should be used for device selection.

The output enable (\overline{OE}) controls the output buffers, independent of device selection. Assuming that $\overline{CE} = \overline{OE} = V_{IL}$ and $\overline{PGM} = V_{IH}$, the output data is valid at the output after address access time from stabilizing of all addresses.

The \overline{CE} to output valid (t_{CE}) is equal to the address access time (t_{ACC}).

Assuming that $\overline{CE} = V_{IL}$, $\overline{PGM} = V_{IH}$ and all addresses are valid, the output data is valid at the outputs after t_{OE} from the falling edge of \overline{OE} .

OUTPUT DESELECT MODE

Assuming that $\overline{CE} = V_{IH}$ or $\overline{OE} = V_{IH}$, the outputs will be in a high impedance state. So two or more ROMs can be connected together on a common bus line.

When \overline{CE} is decoded for device selection, all deselected devices are in low power standby mode.

STANDBY MODE

The TC57H1024AD has a low power standby mode controlled by the \overline{CE} signal.

By applying a high level to the \overline{CE} input, the TC57H1024AD is placed in the standby mode which reduce the operating current to 100 μ A by applying MOS-high level (V_{CC}) and then the outputs are in a high impedance state, independent of the \overline{OE} inputs.

PROGRAM MODE

Initially, when received by customers, all bits of the TC57H1024AD are in the "1" state which is erased state.

Therefore the program operation is to introduce "0s" data into the desired bit locations by electrically programming.

The levels required for all inputs are TTL. The TC57H1024AD can be programmed any location at anytime -- either individually, sequentially, or at random.

PROGRAM VERIFY MODE

The verify mode is to check that the desired data is correctly programmed on the programmed bits.

The verify is accomplished with \overline{OE} and \overline{CE} at V_{IL} and \overline{PGM} at V_{IH} .

PROGRAM INHIBIT MODE

Under the condition that the program voltage (+12.75V) is applied to V_{pp} terminal, a high level \overline{CE} or \overline{PGM} input inhibits the TC57H1024AD from being programmed.

Programming of two or more EPROMs in parallel with different data is easily accomplished. That is, all inputs except for \overline{CE} or \overline{PGM} may be commonly connected, and a TTL low level program pulse is applied to the \overline{CE} and \overline{PGM} of the desired device only and TTL high level signal is applied to the other devices.

HIGH SPEED PROGRAM OPERATION

The device is set up in the high speed programming mode when the programming voltage (+12.75V) is applied to the V_{pp} terminal with $V_{CC}=6.25V$ and $\overline{PGM}=V_{IH}$.

The programming is achieved by applying a single TTL low level 0.1ms pulse the \overline{PGM} input after addresses and data are stable. Then the programmed data is verified by using Program Verify Mode.

If the programmed data is not correct, another program pulse of 0.1ms is applied and then programmed data is verified. This should be repeated until the program operates correctly (max. 25 times).

When programming has been completed, the data in all addresses should be verified with $V_{CC}=V_{PP}=5V$.

HIGH SPEED PROGRAM OPERATION

FLOW CHART

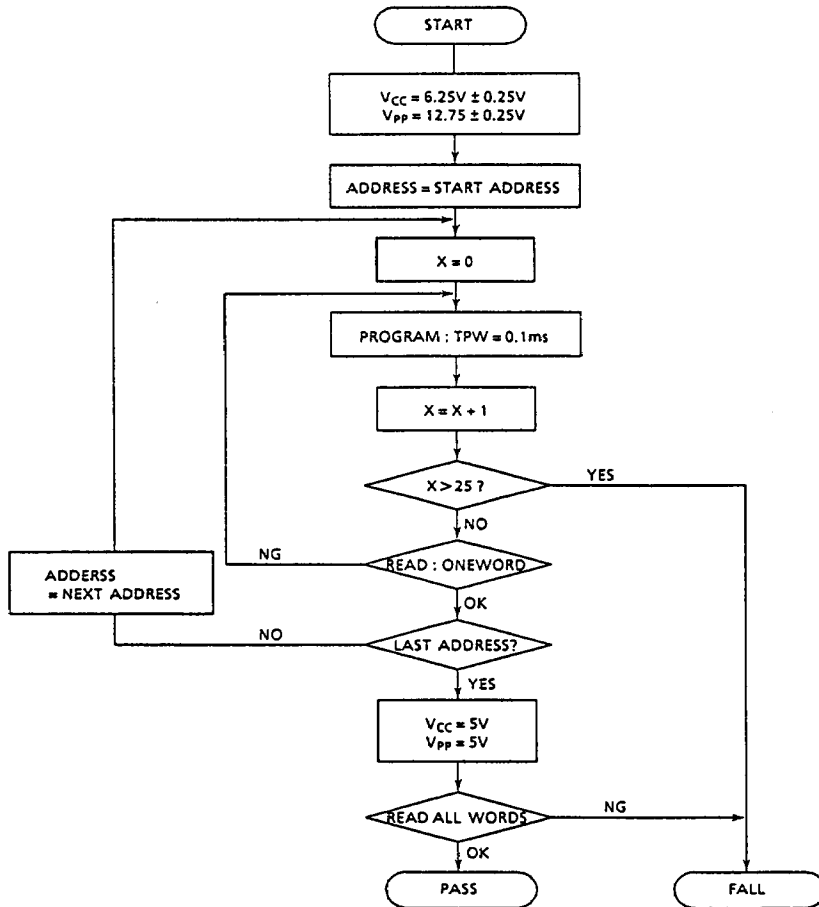

ELECTRIC SIGNATURE MODE

Electric signature mode allows to read out a code from TC57H1024AD which identifies it's manufacture and device type.

The programming equipment may read out manufacturer code and device code from TC57H1024AD by using this mode before program operation and automatically set program voltage (V_{PP}) and algorithm.

Electric Signature mode is set up when 12V is applied to address line A9 and the rest of address lines is set to V_{IL} in read operation. Data output in this conditions is manufacturer code. Device code is identified when address A0 is set to V_{IH}.

These two codes possess an odd parity with the parity bit of (D7).

The following table shows electric signature of TC57H1024AD.

SIGNATURE	PINS																HEX DATA	
	A ₀	D ₁₅	D ₁₄	D ₁₃	D ₁₂	D ₁₁	D ₁₀	D ₉	D ₈	D ₇	D ₆	D ₅	D ₄	D ₃	D ₂	D ₁		D ₀
Manufacturer Code	V _{IL}	*	*	*	*	*	*	*	*	1	0	0	1	1	0	0	0	**98
Device Code	V _{IH}	*	*	*	*	*	*	*	*	1	0	0	0	1	0	0	1	**89

Notes: A₉=12V ± 0.5V, A₁ - A₈, A₁₀ - A₁₅, CE, OE = V_{IL}, PGM = V_{IH}

*: Don't care

TC57H1024AD-85,100

OUTLINE DRAWINGS

- Cerdip DIP

WDIP40-G-600A

Unit: mm

