

SYSTEM CATALOG

# Mobile Solutions

s e m i c o n d u c t o r

<http://www.semicon.toshiba.co.jp/eng>

# Toshiba Semiconductor Devices for Mobile Applications

Mobile communications via cellular phones and PDAs are changing the way we live. Toshiba's semiconductor technology supports the hardware of mobile handsets. We are committed to ensuring the highest quality in both design and production so you can put our best-in-class IC capability to work for you as smoothly as possible.

Pushing the limits of what is possible in mobile electronics, we are seeking a new paradigm of communications.

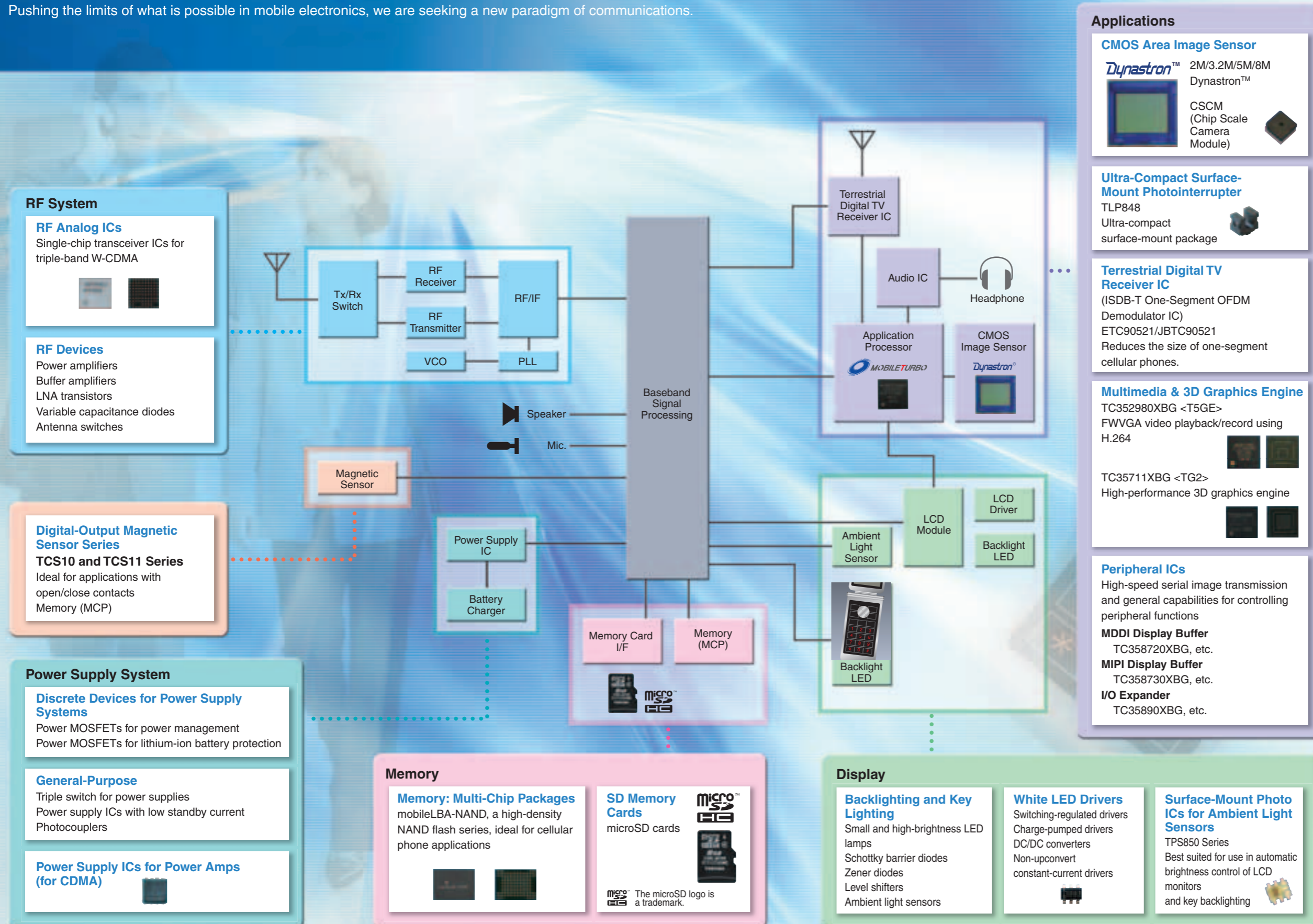

**RF System**

**RF Analog ICs**  
Single-chip transceiver ICs for triple-band W-CDMA

**RF Devices**  
Power amplifiers  
Buffer amplifiers  
LNA transistors  
Variable capacitance diodes  
Antenna switches

**Digital-Output Magnetic Sensor Series**  
**TCS10 and TCS11 Series**  
Ideal for applications with open/close contacts  
Memory (MCP)

**Power Supply System**

**Discrete Devices for Power Supply Systems**  
Power MOSFETs for power management  
Power MOSFETs for lithium-ion battery protection

**General-Purpose**  
Triple switch for power supplies  
Power supply ICs with low standby current  
Photocouplers

**Power Supply ICs for Power Amps (for CDMA)**

**Memory**

**Memory: Multi-Chip Packages**  
mobileLBA-NAND, a high-density NAND flash series, ideal for cellular phone applications

**SD Memory Cards**  
microSD cards

The microSD logo is a trademark.

**Display**

**Backlighting and Key Lighting**  
Small and high-brightness LED lamps  
Schottky barrier diodes  
Zener diodes  
Level shifters  
Ambient light sensors

**White LED Drivers**  
Switching-regulated drivers  
Charge-pumped drivers  
DC/DC converters  
Non-upconvert  
constant-current drivers

**Surface-Mount Photo ICs for Ambient Light Sensors**  
TPS850 Series  
Best suited for use in automatic brightness control of LCD monitors and key backlighting

**Applications**

**CMOS Area Image Sensor**  
*Dynastron™* 2M/3.2M/5M/8M  
*Dynastron™*  
CSCM (Chip Scale Camera Module)

**Ultra-Compact Surface-Mount Photointerrupter**  
TLP848  
Ultra-compact surface-mount package

**Terrestrial Digital TV Receiver IC**  
(ISDB-T One-Segment OFDM Demodulator IC)  
ETC90521/JBTC90521  
Reduces the size of one-segment cellular phones.

**Multimedia & 3D Graphics Engine**  
TC352980XBG <T5GE>  
FWVGA video playback/record using H.264  
TC35711XBG <TG2>  
High-performance 3D graphics engine

**Peripheral ICs**  
High-speed serial image transmission and general capabilities for controlling peripheral functions  
**MDDI Display Buffer**  
TC358720XBG, etc.  
**MIPI Display Buffer**  
TC358730XBG, etc.  
**I/O Expander**  
TC35890XBG, etc.

**CONTENTS**

CMOS Area Image Sensors <i>Dynastron™</i>	4 - 5
Multimedia Engines Designed for Cellular Phone Applications	6
Multimedia Engines Designed for Cellular Phone Applications	7
Peripheral ICs	8 - 9
Mobile Memories NAND Flash Memory	10
Memory: Multi-Chip Packages	11
NAND Flash Storage	12
Single-Chip Transceiver IC for Triple-Band W-CDMA	13
Digital TV Receiver IC Compact SMD Type LED Lamps	14
White LED Drivers Power Supply ICs for Cellular Phone (CDMA) Power Amps	15
Surface-Mount Photo-IC for Ambient Light Sensor: TPS856 Ultra-Compact Surface-Mount Photointerrupter: TLP848	16
TCS10/11 Digital-Output Magnetic Sensor Series	17
Ultra-Small, Low ON-Resistance Analog Switches ESD Protection Diodes	18
Devices for Small Power Supplies : MOSFETs and CMOS LDO Regulators	19

Note: The system and product names mentioned herein may be trademarks or registered trademarks of respective companies.

# CMOS Area Image Sensor *Dynastron™*

In its pursuit of further miniaturization and higher performance, Toshiba offers a new Dynastron CMOS image sensor with a pixel pitch of 1.75 μm, reduced from 2.2 μm.

The new image sensor is available in pixel counts ranging from 2.0 M to 8 M. The Dynastron technology provides high-quality imaging, thanks to the use of a microlens and an optimized array of photodiodes.

The new image sensor opens up new possibilities for mobile handsets such as camera phones.

\*: Dynastron is a trademark of Toshiba Corporation.



## 2-Megapixel Dynastron™: ET8EM0 (under development)

## 3.2-Megapixel Dynastron™: ET8EM1

## 5-Megapixel Dynastron™: ET8EM2 (under development)

## 8-Megapixel Dynastron™: ET8EN2 (under development)

### ■ Features

- Dynastron technology provides world-class image quality.
- The integrated PLL provides great flexibility in the selection of input clocks.
- Offers blemish correction, gain control, etc.
- Command controlled via the I<sup>2</sup>C bus.

### ■ General Specifications

Item	Specification			
Part Number	ET8EN2	ET8EM2	ET8EM1	ET8EM0
Optical Format	1/2.6 inch	1/3.2 inch	1/4 inch	1/5 inch
Pixel Count	Approx. 8 M (3,280 (H) x 2,464 (V))	Approx. 5 M (2,584 (H) x 1,960 (V))	Approx. 3.2 M (2,060 (H) x 1,548 (V))	Approx. 2 M (1,616 (H) x 1,216 (V))
Cell Size	1.75 μm x 1.75 μm	1.75 μm x 1.75 μm	1.75 μm x 1.75 μm	1.75 μm x 1.75 μm
Output Signaling	RAW	RAW	RAW	YUV/RGB/RAW
Frame Rate	7.5 fps at full resolution	12 fps at full resolution	15 fps at full resolution	UXGA@15 fps VGA@30 fps
Control Bus	I <sup>2</sup> C	I <sup>2</sup> C	I <sup>2</sup> C	I <sup>2</sup> C
ISP	None	None	None	Integrated

ISP: Image Signal Processor

### Dynastron™ Roadmap

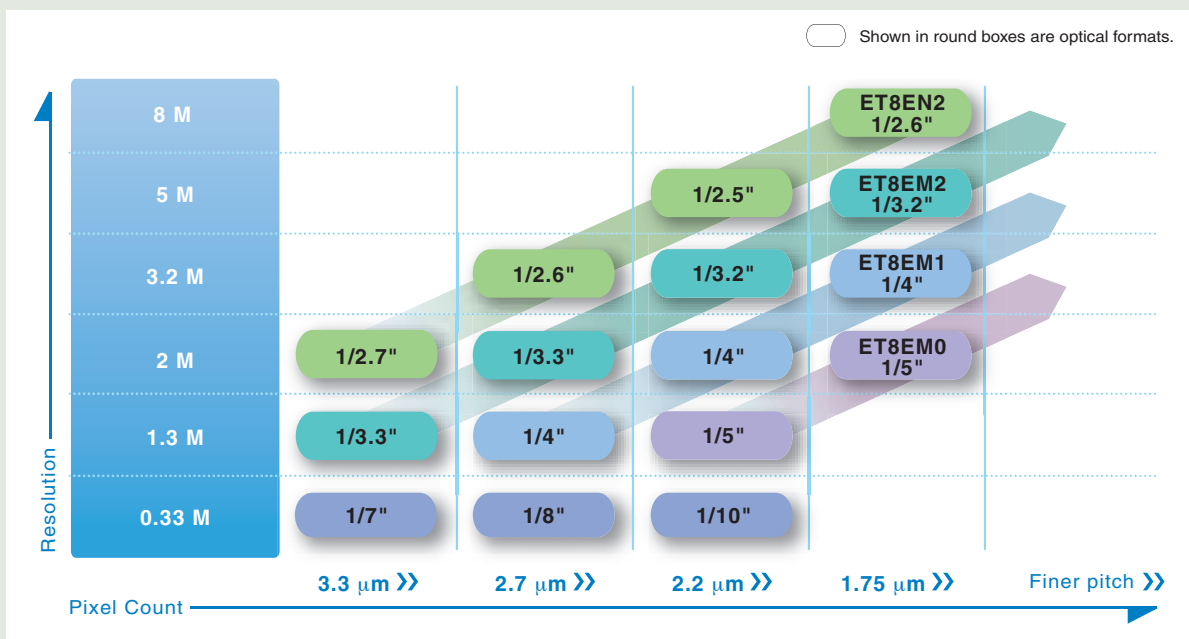

## CSCM (Chip Scale Camera Module)

### The first camera modules manufactured using Through-Chip Via (TCV) technology

Toshiba now offers a family of chip scale camera module (CSCM<sup>\*1</sup>) with a Dynastron™ CMOS image sensor. They are the first<sup>\*2</sup> to use TCV<sup>\*3</sup> technology.

In the last few years, cellular phones and other mobile devices are coming in smaller and smaller form factors. This is driving the need for smaller, yet higher-quality camera modules to be able to incorporate digital camera functionality into these space-critical applications. TCV technology uses a chip structure with built-in pass-through electrodes and allows the mounting and assembly of camera modules in the semiconductor wafer. With solder balls on the bottom of the substrate, the CSCM requires no wire bonding space, delivering a 64% reduction<sup>\*4</sup> in module size compared to Toshiba's conventional camera modules manufactured with the same VGA sensors.

The use of heat-resistant lenses and solder balls permits reflow soldering<sup>\*5</sup> and thus simplifies the pc board mounting of camera modules. This contributes to a reduction in the manufacturing process of surface-mount pc boards.

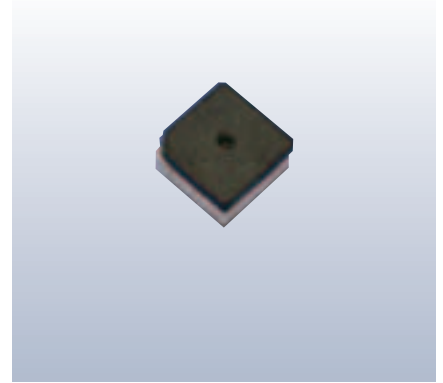

\*1 The chip scale camera module is a ultra-small camera module that allows the mounting and assembly of camera module components at the wafer level.

\*2 As of October 1, 2007, according to a survey by Toshiba.

\*3 Through-Chip Via, for cutting holes and running electrodes through the wafer.

\*4 Comparison with Toshiba's conventional camera modules manufactured with the same sensor chip.

\*5 Surface-mount assembly process in which components are temporarily mounted on the pc board using solder paste, after which the board is passed through a temperature-controlled oven in order to solder the joint.

#### ■ Comparison Between the Conventional and CSCM Camera Modules

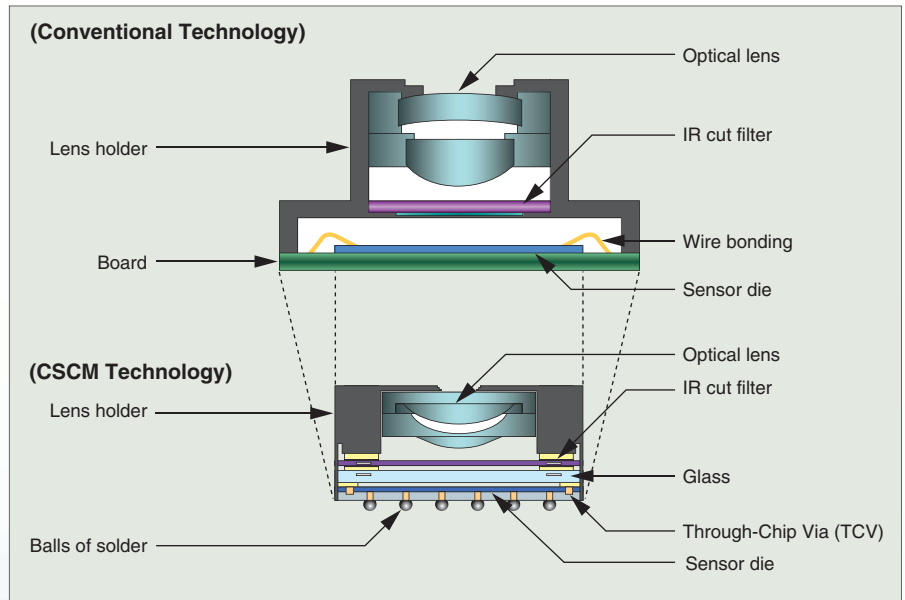

#### ■ General Specifications

Part Number	TCM9200MD
Module Size	6.31 mm (X) x 6.41 mm (Y) x 4.35 mm (H)
Total Pixel Count	1,648 (H) x 1,216 (V) (UXGA)
Cell Size	2.2 μm (H) x 2.2 μm (V)
Output Signaling	YUV/RGB/RAW
Output Format	8-bit parallel
Frame Rate	15 frames per second (UXGA output) 30 frames per second (VGA output)
Control Signal	I <sup>2</sup> C bus

Part Number	TCM9000MD
Module Size	4.00 mm (X) x 4.00 mm (Y) x 2.27 mm (H)
Total Pixel Count	648 (H) x 492 (V) (VGA)
Cell Size	2.2 μm (H) x 2.2 μm (V)
Output Signaling	YUV/RAW
Output Format	8-bit parallel
Frame Rate	30 frames per second (VGA output)
Control Signal	I <sup>2</sup> C bus

\*For detailed information, contact your nearest Toshiba sales representative.

\*The specifications of the products being developed are subject to change.

# Multimedia Engines Designed for Cellular Phone Applications

Toshiba has launched a new multimedia engine specifically designed for cellular phone applications. Designated as the T5GE, the new multimedia engine is a successor to the T5G and contains three hardware accelerators—a video codec, a 3D graphics accelerator and a JPEG codec—for faster execution of video or still image shooting, one-segment TV reception, 3D games and the like. The video codec supports H.264 and MPEG-4 (FWVGA) encoding/decoding. The powerful 3D graphics accelerator expands the possibilities for games and other applications of cellular phones. The JPEG codec supports the shooting of still images having up to 5 megapixels in order to satisfy a demand for a higher resolution; it also offers fast processing that enables continuous shooting. Additionally, the T5GE incorporates an LCD controller that supports LCD display at resolutions up to FWVGA (864 x 480).

## T5GE TC352980XBG

### Features

#### Video codec

H.264 codec: Supports FWVGA-size (864 x 480) encoding and decoding at a frame rate of 30 fps.

MPEG-4 codec: Supports up to FWVGA-size (864 x 480) encoding and decoding at a frame rate of 30 fps.

H.263 video codec, camera input (filtering, zoom-out and rotation) and video output (filtering, zoom-out, zoom-in and rotation).

#### Audio codec

AMR-compliant; ITU-T G.726-compliant; MP3 audio encoding/decoding; WMA audio encoding/decoding; PCM input/output; MP4 demultiplexing; bitstream input/output; video phone (ITU-T H.223); MPEG2-TS (ITU-T H.222.0)

#### 2D/3D graphics

#### JPEG codec

JFIF-compliant and JPEG Baseline-compliant; JPEG PART 2-compliant (ISO/IEC 10918-2); YUV 4:4:4, YUV 4:2:2 and YUV 4:2:0 input formats

#### LCD controller

FWVGA resolution; support for two LCD panels; RGB and YUV output formats; composition of up to four layers; synchronous and asynchronous interfaces; simultaneous display of FWVGA and TV; frame storage

#### Camera interface: Direct connections with two cameras; YUV 4:2:2 camera input

#### On-chip memories: Graphics eDRAM and mobile DDR SDRAM

### General Specifications

Item	Specification
Process	90 nm
Power Supply	1.2 V (core); 2.5 V (core); 1.8 to 3.0 V (I/O)
Package Dimensions	11 mm x 11 mm (358 pins)



## TG2 TC35711XBG

### Features

The integrated 3D graphics processor delivers 3D rendering performance of 100 mega-polygons\* (800 megapixels\*) a second.

Contains three processors to realize graphics performance equivalent to tabletop game consoles: a high-performance 3D graphics processor, a MeP (Media Embedded Processor) suitable for multimedia processing and an ARM1176JZF-S CPU core designed specifically for mobile handsets.

Compatible with programmable shaders, which bring realistic shading and reflectivity to mobile handsets.

Incorporates an LCD controller that supports LCD display of WVGA size (480 x 800) and can display WVGA and TV through the video encoder independently and simultaneously.

Integrates a 512-Mbit DDR memory in a stack-up configuration in an SiP package.

Different types of external interfaces are available: SD card, serial I/O, NAND flash memory, DDR memory controller and UART.

### General Specifications

Item	Specification
Process	90 nm
Functions	CPU; 3D graphics; LCD interface; SD card interface; serial I/O; UART; DDR memory controller
Power Supply	1.2 V (core); 1.8 to 3.3 V (I/O)
Package Dimensions	13 mm x 13 mm, 449-pin BGA



\* Peak performance of the graphics core

# Multimedia Engines Designed for Cellular Phone Applications

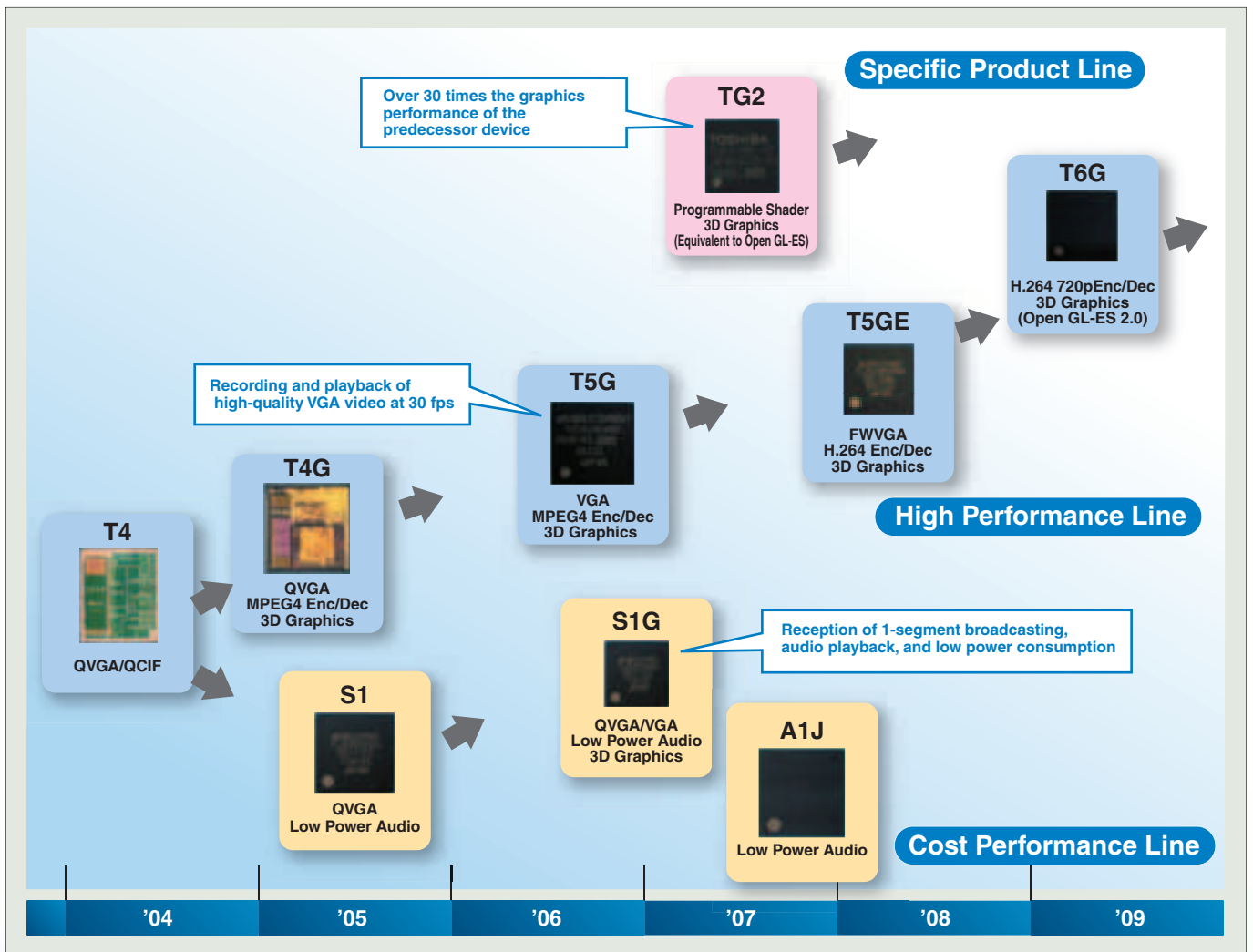

## Key Technologies and Multimedia Performance

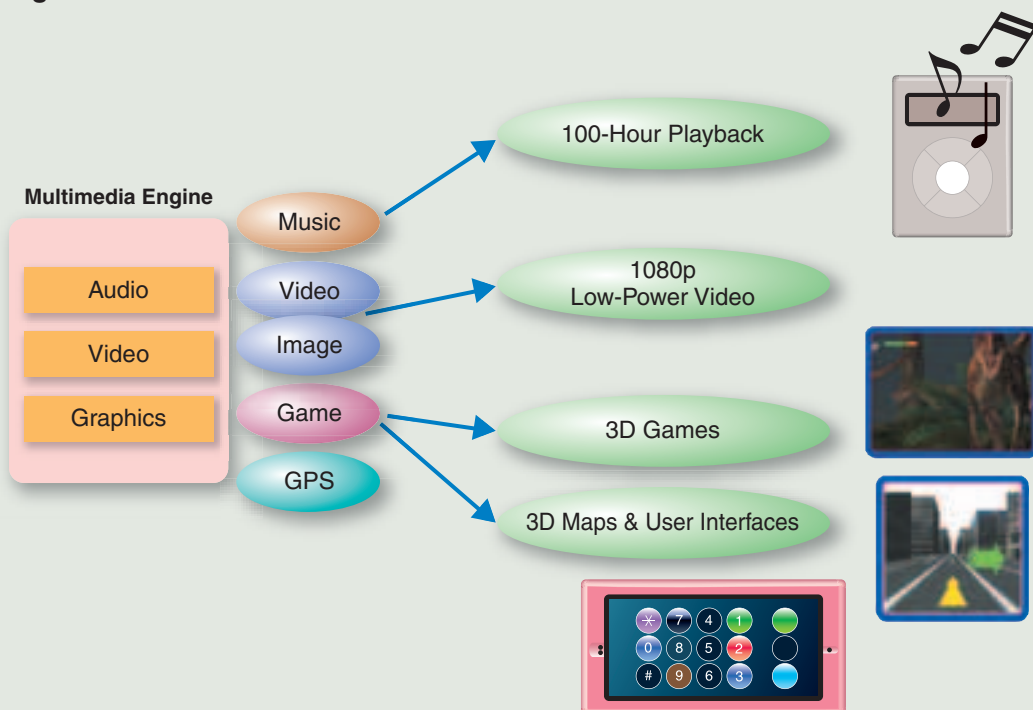

# Peripheral ICs

Toshiba offers peripheral ICs that provide flexible connections between the baseband or application processor in a cellular-phone system and various peripheral devices.

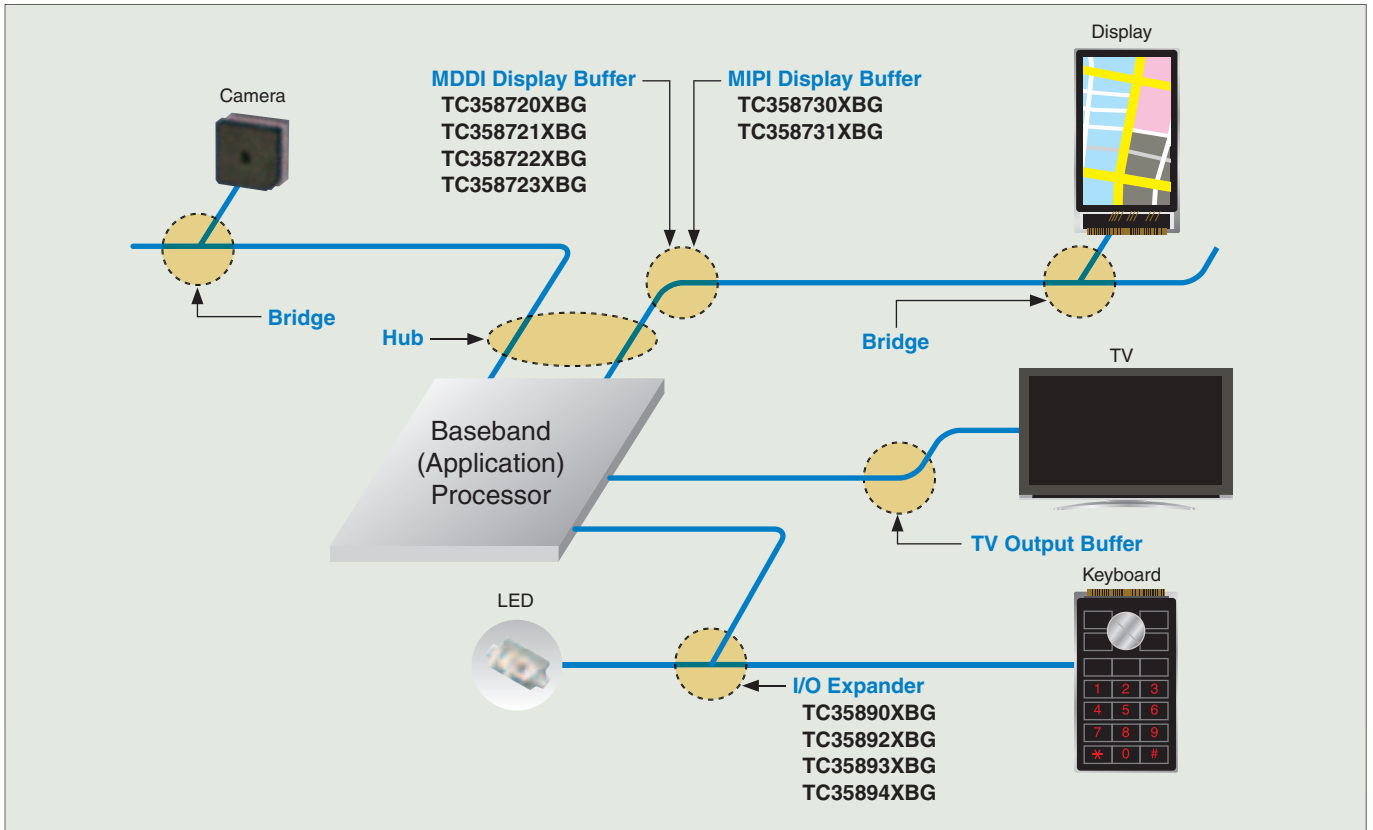

## Examples of Display Buffer Solutions

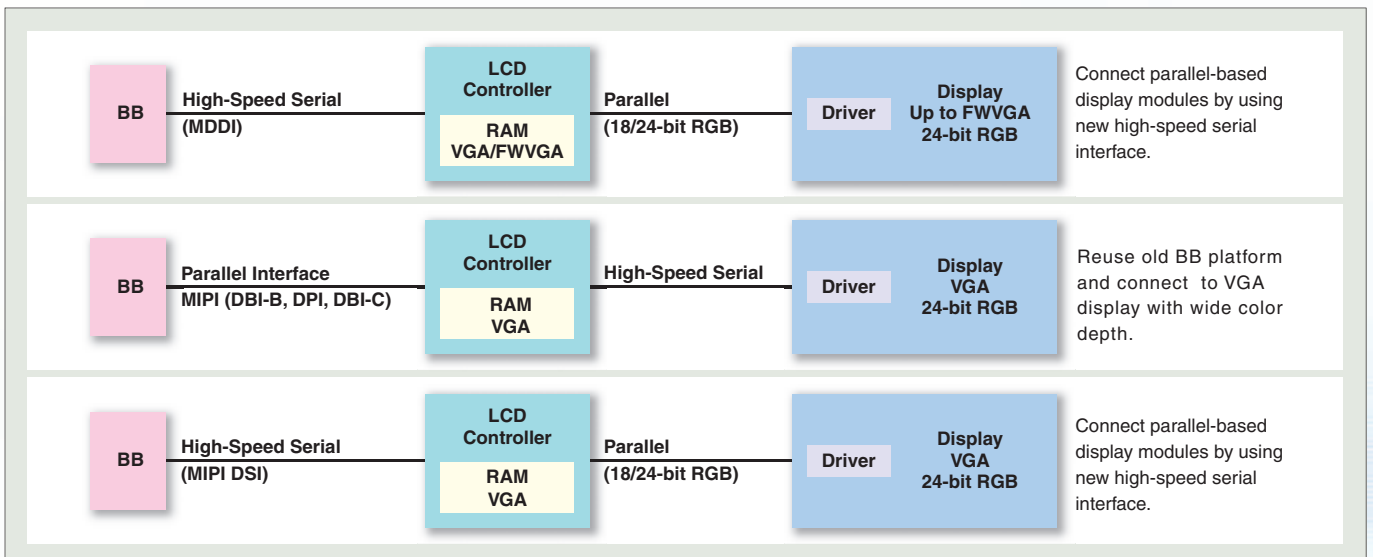

## I/O Expander Example

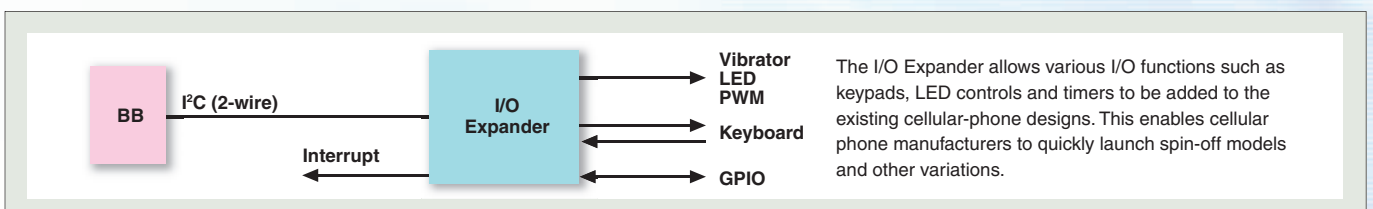

Cellular phones, both clamshell and sliding styles, will continue to evolve with a variety of user interfaces. To address their mechanical and electrical challenges, Toshiba offers a family of highly integrated peripheral ICs: the TC358720XBG and TC358721XBG MDDI-based VEGAMagiq display buffers; the TC358730XBG and TC358731XBG MIPI-based display buffers; and the TC35890XBG, TC35892XBG, TC35893XBG and TC35894XBG I/O Expanders. The I/O Expander allows typical baseband or application processor packages to be kept at a minimum pin count by enabling I/O pin expansion at the location where needed. Display buffers support not only high-speed serial interfaces for image data transmission but also traditional interfaces for peripheral device control.

### MDDI Display Buffer: VEGAMagiq TC358720XBG, TC358721XBG

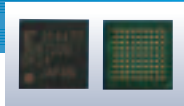

#### ■ Features

- MDDI Client interface with data rates of up to 400 Mbps
- Support for a VGA-sized primary LCD panel and a QCIF+-sized secondary LCD panel
- Traditional peripheral interfaces: I<sup>2</sup>C, SPI, GPIO and PWM
- Input clock frequency range between 32.768 kHz and 20 MHz
- LCD video transfer rate: VGA at 60 fps

#### ■ General Specifications

Item	Specification
Process	130 nm
Power Supply	1.5 V (core); 2.6 V (eDRAM); 1.8 to 3.3 V (I/O); 1.5 V & 1.8 V (MDDI I/O)
Package Dimensions	6 mm x 6 mm (81 pins)

### MIPI Display Buffer TC358730XBG

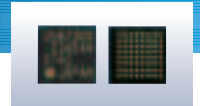

#### ■ Features

- Support for two interfaces: MIPI™ DBI Type B and MIPI™ DPI
- High-speed serial output interface (T-HSSI: Toshiba High-Speed Serial Interface)
- Full frame buffering of VGA resolution
- PWM for backlight control
- Input clock frequency range between 32.768 kHz and 19.2 MHz

#### ■ General Specifications

Item	Specification
Process	90 nm
Power Supply	1.8 V (core); 1.8 V (I/O); 2.5 V (eDRAM)
Package Dimensions	5 mm x 5 mm (64 pins)

### MDDI Display Buffer: VEGAMagiq-W TC358722XBG, TC358723XBG



#### ■ Features

- MDDI Client interface with data rates of up to 400-Mbps
- Support for a FWVGA-sized primary LCD panel and a QCIF+-sized secondary LCD panel
- Traditional peripheral interfaces: I<sup>2</sup>C, SPI, GPIO and PWM
- Input clock frequency range between 32.768 kHz and 20 MHz
- LCD video transfer rate: FWVGA at 60 fps

#### ■ General Specifications

Item	Specification
Process	130 nm
Power Supply	1.5 V (core); 2.6 V (eDRAM); 1.8 to 3.3 V (I/O); 1.5 V & 1.8 V (MDDI I/O)
Package Dimensions	6 mm x 6 mm (100 pins)

### MIPI Display Buffer TC358731XBG

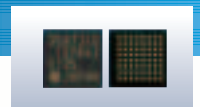

#### ■ Features

- Baseband processor interfaces: MIPI™ DBI Type B, MIPI™ DPI and MIPI™ DBI Type C
- High-speed serial input interface (MIPI™ DSI)
- Full frame buffering of VGA resolution
- PWM for peripheral device control
- Input clock frequency range between 32.768 kHz and 19.2 MHz

#### ■ General Specifications

Item	Specification
Process	90 nm
Power Supply	1.8 V (core); 1.8 V (I/O); 2.5 V (other)
Package Dimensions	5 mm x 5 mm (64 pins)

### I/O Expander TC35890XBG, TC35892BG, TC35893XBG, TC35894XBG

#### ■ Features

- Low-power operation ● I<sup>2</sup>C interface; 2 x 2 to 8 x 12 keypad; PWM timers; general-purpose I/O pins (GPIO)
- Up to 24 general-purpose I/O pins

#### ■ General Specifications

Item	TC35890XBG	TC35892XBG	TC35893XBG	TC35894XBG
Features	Up to 24 GPIO pins; crystal oscillation; support for dual power supplies	Up to 24 GPIO pins; on-chip RC oscillation; crystal oscillation	Up to 20 GPIO pins; on-chip RC oscillation	Up to 24 GPIO pins; on-chip RC oscillation; crystal oscillation
Power Supply	1.7 to 3.6 V	1.62 to 2.7 V	1.62 to 2.7 V	1.62 to 2.7 V
Package Dimensions	5 mm x 5 mm (36 pins)	3.5 mm x 3.5 mm (36 pins)	3.0 mm x 3.0 mm (25 pins)	3.5 mm x 3.5 mm (36 pins)
Package				

# Mobile Memories

## Well-proven NAND flash

Invented by Toshiba, NAND flash has gained popularity in the cellular phone market. Toshiba manufactures all of its NAND flash products in Japan, which are renowned for their quality and reliability.

## Available in space-saving configurations like MCP packages and microSD cards

Several memory chips are stacked up vertically in MCP packages to get the maximum space-saving advantage possible. Also, ultra-small microSD cards are designed specifically for cellular phones to allow size reduction. These flash memory products contribute to enabling form-factor miniaturization and feature-rich cellular phones.

## Wide variety of memory solutions

Embedded memories in MCP packages and microSD cards, especially multi-level cell (MLC) NAND flash products, provide total memory solutions for cellular phone applications.

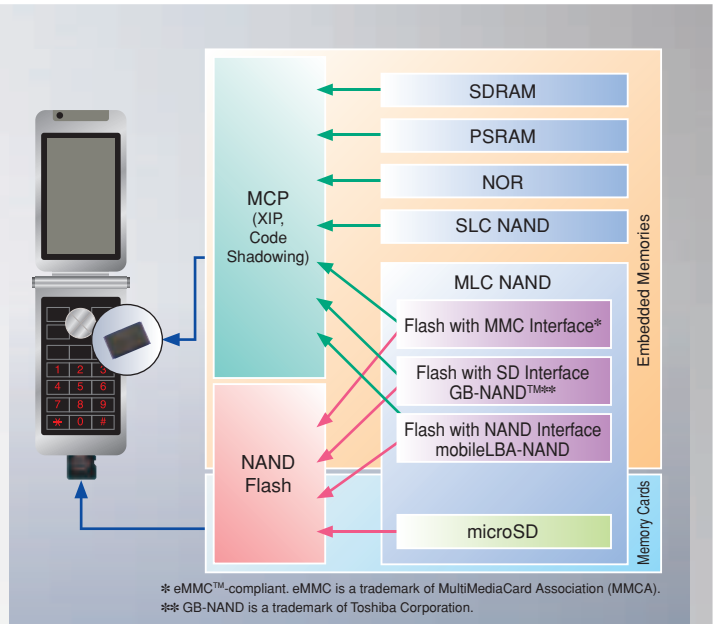

XIP (eXecute-In-Place): A method of executing programs directly from NOR flash memory. Primarily used in GPRS cellular phones in China and Europe.

Code shadowing: A method of copying program code at boot-up from the SLC NAND flash to synchronous dynamic RAM (SDRAM) to run applications. Widely used in high-end cellular phones in Japan and South Korea.

# NAND Flash Memory



To meet the rapidly growing demand for high-capacity storage, Toshiba offers the industry's largest 16-Gbit and 32-Gbit NAND flash memories fabricated with the advanced 43-nm process technology.

## Features

- Advanced 43-nm process and multi-level cell technologies have enabled the product to have a capacity of 16 and 32 Gbits in the same package size as before.
- The new NAND flash memory provides faster write performance by increasing the page size and optimizing the memory cell control system.
- Stacked-die packaging technologies allow large-capacity memory cards.

## Roadmap for NAND Flash Memory Chips and Cards

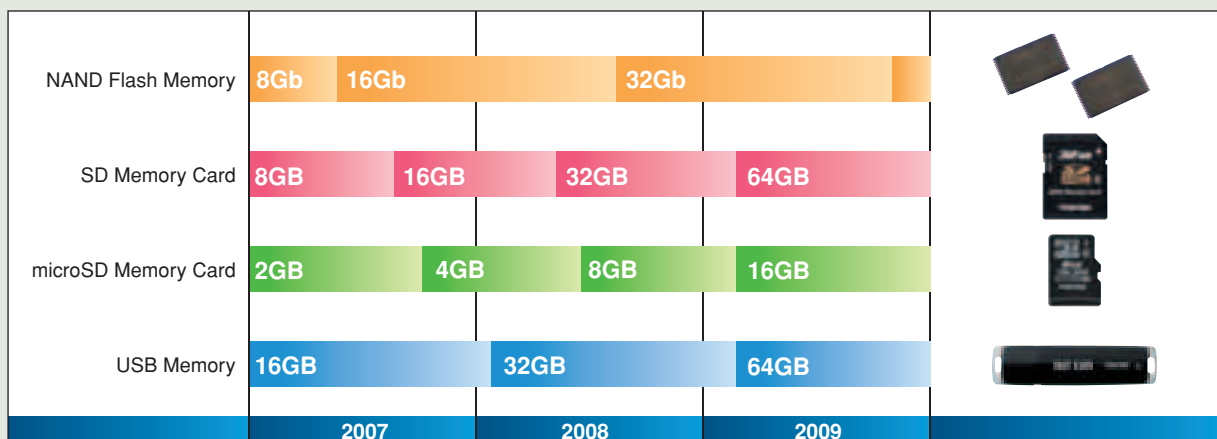

# Memory: Multi-Chip Packages

More and more features are being added to mobile devices like cellular phones, such as the storing and playback of still pictures, videos and music, and game playing capabilities. This is driving the need for processing large amounts of data at high speeds. On the other hand, multi-chip packages (MCPs) are becoming increasingly popular for die stacking to save board space.



## ■ Features

- Various types of memory can be combined in a single package.
- Up to nine layers can be stacked up (including inter-die spacers) in a package with a thickness of 1.4 mm. Up to five layers can be stacked up in a package with a thickness of 1.0 mm.
- Samples of high-density mobileLBA NAND flash memories are now available. The new mobileLBA NAND flash memories reduce the workload of a host controller. Manufacturers can, on the same chip, define an SLC area best suited for high-speed reads and writes, separately from an MLC area optimized for storage of a large amount of data. The 2-Gbit, 4-Gbit and 8-Gbit versions allow their full capacity to be allocated as SLC, while the 16-Gbit and 32-Gbit versions can support up to 8 Gbits of SLC.

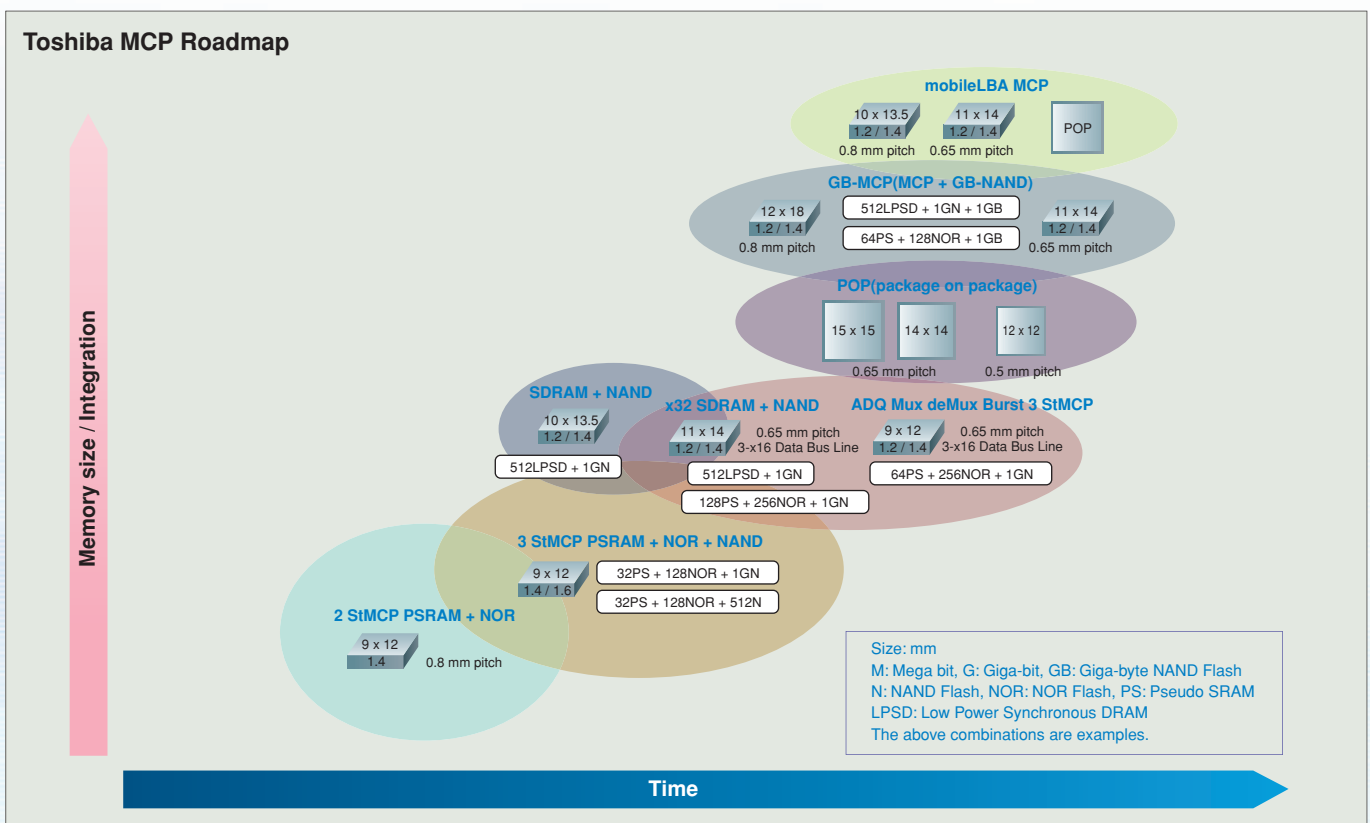
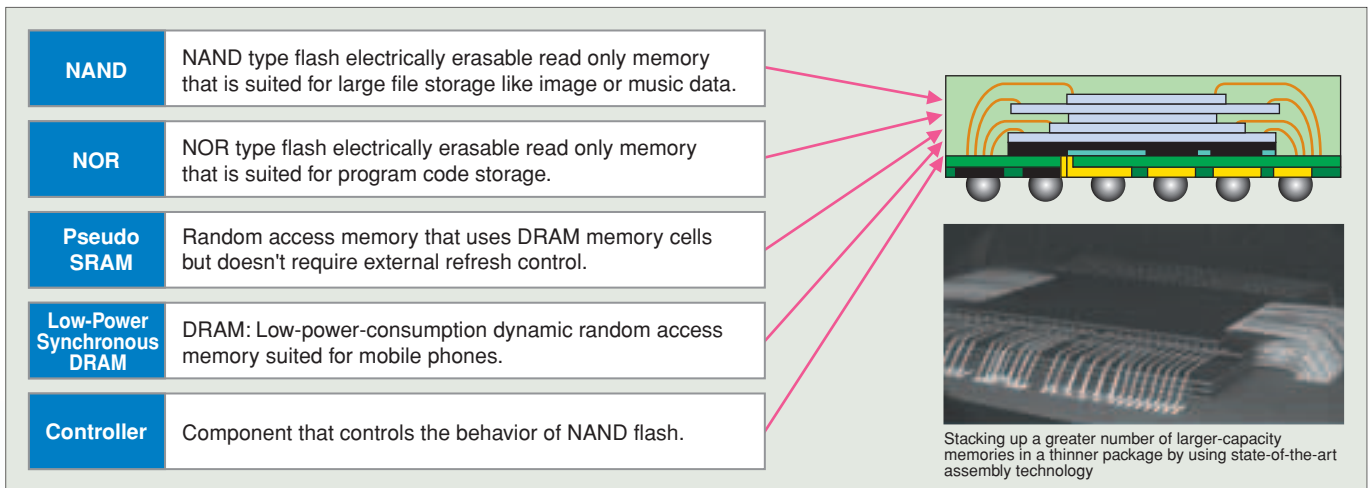

# NAND Flash Storage



## SD Memory Card Family



Multipurpose SD Memory Cards also provide high-level copyright protection.

### SD Memory Cards

Ultra high-speed **CLASS 6**



### SD Memory Cards

High-speed **CLASS 4**



SDHC Memory Cards use the FAT32 filesystem to address large memory space.

### SDHC Memory Cards

Ultra high-speed **CLASS 6**



### SDHC Memory Cards

High-speed **CLASS 4**



microSD Memory Cards are the smallest SD Memory Cards.

### microSD Memory Cards

High-speed



As digital devices become more sophisticated, they need more data storage capacity.

### microSDHC Memory Cards

High-speed **CLASS 4**



## SD Speed Class

**CLASS 2**

**CLASS 4**

**CLASS 6**

The SD Speed Class indicates the minimum read/write data transfer rate for the SD Memory Card based on the SD Card Association standards.

The minimum data transfer rate of Class 2, Class 4 and Class 6 cards is 2 MB/s, 4 MB/s and 6 MB/s respectively.

## USB Flash Memory

**TransMemory**

Just plug it into a USB port and it is automatically recognized. Whether moving data around the office or sharing photos with a friend, this compact, highly portable USB Flash Memory is your data link.

**Windows Vista®** and **ReadyBoost™** supported.



U2K Series (standard models)



U2G Series (high-capacity model)

## Solid State Drive (SSD)

High-speed, high capacity

Serial ATA interface

Product offerings: Module, 1.8-inch, 2.5-inch types

Capacity: 32 GB, 64 GB, 128 GB

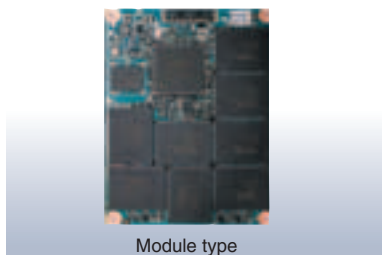

Module type



1.8-inch type



The SD, SDHC, microSD and microSDHC logos are trademarks. **TransMemory** The TransMemory is a registered trade mark of Toshiba Corporation. Windows Vista® and ReadyBoost™ are registered trademarks or trademarks of Microsoft Corporation in the USA and other countries.

# Single-Chip Transceiver IC for Triple-Band W-CDMA

The market of W-CDMA cellular phones has been rapidly expanding, promoting a movement for greater versatility and use of a wider frequency band. This trend also demands more highly-integrated, smaller RF-LSI chips.

The new RF-LSI chip, TB31345WLG, combines the two previous chips, the TB31341FTG low noise amplifier (LNA) and the TB31342XLG transceiver (TRX). Additionally, the TB31345WLG is housed in the industry's smallest-class wafer-level chip size package (WCSP\*).

The TB31345WLG covers the BAND V (800-MHz) area in addition to the BAND I (2-GHz) area for roaming services.

The receiver's built-in lowpass filter (LPF) provides excellent characteristics for reducing the GSM and CDMA2000 interference noise.

The SiGe BiCMOS technology enables the TB31345WLG to operate with low power consumption and low error vector magnitude (EVM), thus providing long standby and talk times.

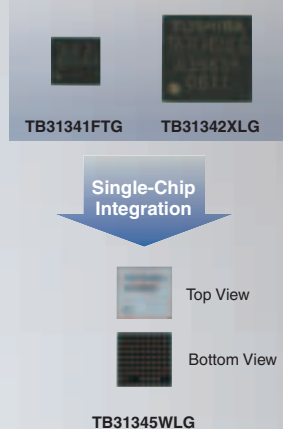

## TB31345WLG

### ■ Features

- Low current consumption: TX = 66 mA (@ +4 dBm output power in normal operating mode); 69 mA (@ +4 dBm output power in lcc-up HSDPA mode)  
RX = 36 mA
- Frequency bands: Band I (2-GHz band), Band V/VI (800-MHz band), Band IX (1.7-GHz band)
- Low EVM: RX = 10%; TX = 3%
- Fast lock & low noise: Built-in fractional-N PLL, VCO and loop filter
- Reduced interference: Receiver's built-in lowpass filter (LPF) for reducing GSM and CDMA2000 interference noise
- Small, thin package: 96-pin S-UFLGA96 (4.13 x 4.16 x 0.6 mm), 0.4-mm ball pitch (WCSP\*)

\*: WCSP: Wafer-Level Chip Size Package

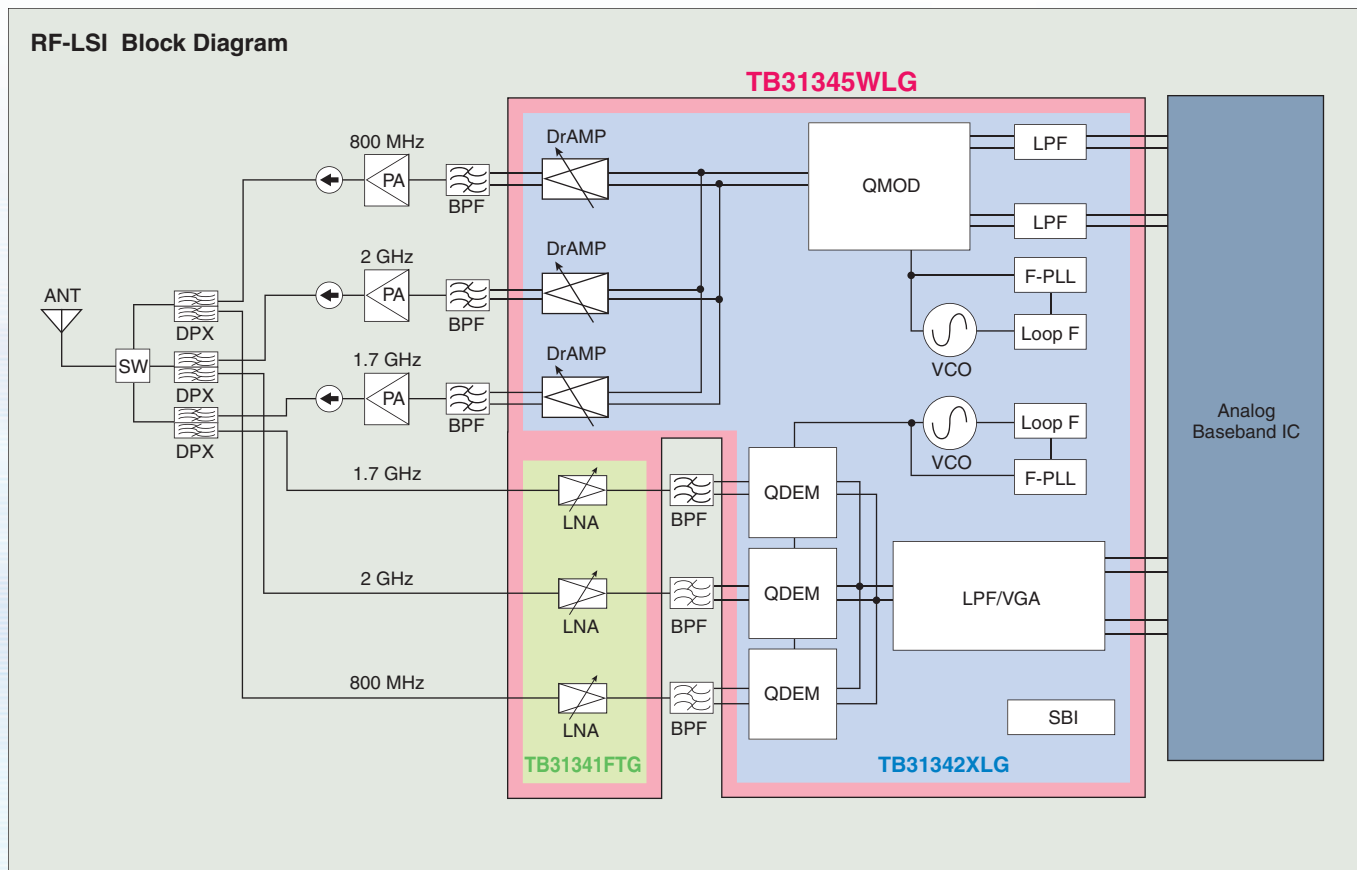

# Digital TV Receiver IC

Designated the ETC90521 in bare-die form and JBTC90521 in solder-bumped form, an OFDM demodulation IC is available in production quantities, which is specifically designed for the ISDB-T 1-segment of Japanese digital TV broadcasting for mobile receivers.

## ■ Features

- Can receive terrestrial digital broadcasting and ISDB-T 1-segment broadcasting.
- Fabricated using the 90-nm technology and offered in package-less forms (bare-die or solder-bumped) to minimize system size.
- Contains all hardware necessary for OFDM demodulation such as memory and an A/D converter, eliminating the need for external components.
- The self-contained ETC90521/JBTC90521 can run on its own (except for initialization, channel selection, etc.), reducing the workload of the host CPU.
- Provides improved mobile reception performance and channel switching times than the predecessor, TC90501FLG.

The successor to this IC is now being developed: TC90541 (single chip RF-CMOS 1-segment receiver/ tuner).

## Offers High Brightness with Low Current Drive

# Compact SMD Type LED Lamps

## ■ Features

- Package dimensions: 1.6 (L) x 0.8 (W) x 0.45 (H) mm (Including lead length)
- New LED chip structure achieving high-brightness and low-current drive (TLxV1022 Series).
- Can be used as a replacement for the predecessor high-brightness LED (TLxV1022 Series).
- ROHS compatible

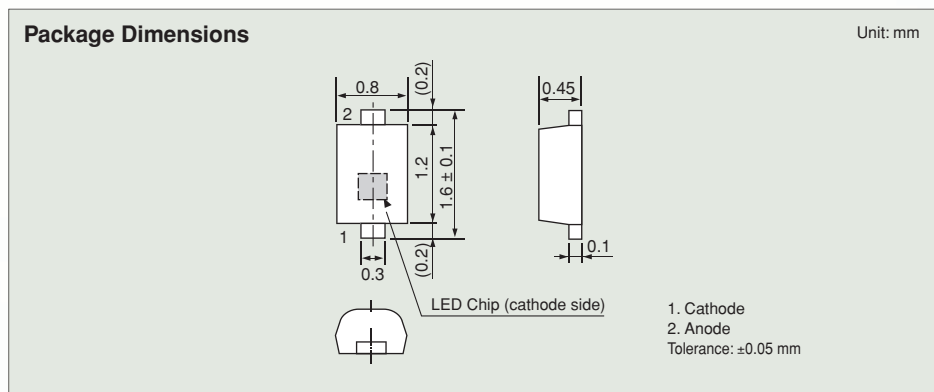

## ■ Product Offerings

@Ta = 25°C

Series Name	Part Number	Color	Dominant Wavelength λd Typ. (nm) @If = 5 mA	DC Forward Voltage VF (V) @If = 5 mA		Reverse Current IR (μA) @VR = 4 V	Luminous Intensity Iv (mcd) @If = 5 mA		Available Bins
				Typ.	Max		Min	Typ.	
TLxV Series (InGaAlP)	*TLRV1022(T14, F)/(T15, F)	Red	630	1.8	2.1	10	4.76	15	# JK
	*TLRMV1022(T14, F)/(T15, F)	Red	626	1.8	2.1	10	4.76	20	# JK
	*TLSV1022(T14, F)/(T15, F)	Red	613	2.0	2.3	10	8.5	30	# KL
	*TLOV1022(T14, F)/(T15, F)	Orange	605	2.0	2.3	10	8.5	38	# KL
	*TLAV1022(T14, F)/(T15, F)	Amber	592	2.0	2.3	10	8.5	25	# KL
	*TLVY1022(T14, F)/(T15, F)	Yellow	587	2.0	2.3	10	8.5	25	# KL
	*TLGV1022(T14, F)/(T15, F)	Green	571	2.0	2.3	10	4.76	14	# JK
*TLPGV1022(T14, F)/(T15, F)	Pure green	561	2.0	2.3	10	1.53	3.5	# FG	

\*: Sealed in a moisture-proof bag.

#: For the available luminous intensity bins and further details, contact your nearest Toshiba sales representative.

## Drives White LEDs for LCD Backlight at High Efficiency

# White LED Drivers

The family of white LED drivers features high brightness with low power consumption, helping to reduce product size. It is ideal for LCD backlight and secondary camera flash applications. Both switching and charge-pump DC/DC converters are available.

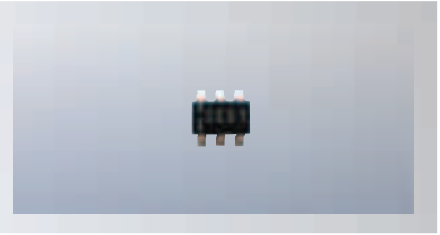

### ■ Features

- Small packaging: SOT23-6, VQON24, PLP
- High efficiency: >85% (switching-regulated type)
- Low noise: No inductors required (charge-pumped type)
- Analog dimming control
- Multiple output capability for system integration (charge-pumped type)
- High quality: Protection circuitry (OVD)
- High accuracy:  $\pm 5\%$  output current

### ■ Product Offerings

#### Switching-Regulated Drivers

Part Number	Features	Status
TB62731FUG	Temperature compensation circuit	Available
TB62732FUG	Small form factor	Available
TB62734FUG	Analog dimming; OVD	Available
TB62736FUG	High efficiency; analog dimming	Available
TB62737FUG/FPG	OVD; high efficiency	Available
TB62756FUG	PWM dimming; high efficiency	Available
TB62757FUG/FPG	PWM dimming; OVD; high efficiency	Available
TB62750FTG	High current (up to 800 mA)	Under development
TB62752AFUG/TB62755FPG	Multiple output lines (up to 8 LEDs)	Available
TB62752BFUG	OVD threshold = 31.5 V (typ.)	Available
TB62754AFNG	Medium-sized LCD backlighting	Available

#### Charge-Pumped Drivers

Part Number	Features	Status
TCA62753FUG	5-V constant-voltage output	Available

Non-step-up-type constant-current drivers are also available.

## Optimizes Power Amplifier Efficiency

# Power Supply ICs for Cellular Phone (CDMA) Power Amps

The power supply ICs for cellular phone power amps combine bypass MOSFET with a small, high-efficiency, synchronous-current-mode step-down regulator. They are ideal for optimizing the efficiency of CDMA and W-CDMA power amps to increase battery life.



### ■ Features

- Small packaging
- High efficiency: >80%
- Low Ron bypass MOSFET
- Variable output voltage
- High quality: Protection circuitry

### ■ Product Offerings

Part Number	Features	Status
TB62504FMG	Small voltage reference	Available

## Surface-Mount Photo-IC for Ambient Light Sensor: TPS856

The TPS856 is a photo-IC that incorporates a photodiode, a current amplifier and a luminous-efficiency correction function in a single chip. This device has high sensitivity and excellent output linearity relative to change in the ambient brightness of the operating environment. The device also features little variation in light current ratio between light sources and so supports operation at a lower voltage than the previous series. Moreover, the power dissipation of this photo-IC is reduced even in standby mode through the use of a newly added standby pin. As a power-saving device with further enhanced functionality, the TPS856 contributes to power saving in various display devices.



### ■ Features

- Small and thin surface-mount package: 1.6 x 1.6 x 0.55 mm (typ.)
- Current linear output type: incorporating a photodiode and a current amplifier in a single chip
- High sensitivity: light current ( $I_L$ ) = 40 to 80  $\mu\text{A}$  @  $E_v = 100$  lx using fluorescent light
- Light current ratio ( $I_L$ @ incandescent light /  $I_L$ @ fluorescent): 1.0 x (typ.)
- Low supply voltage:  $V_{CC} = 1.8$  to 5.5 V
- Built-in standby function
- Silicon is used as the chip material. This product can be used in place of a CdS cell.

### ■ Comparisons of the New TPS856 to the Conventional TPS852 and TPS853

Part Number	Package Dimensions (mm)	Power Supply (V)	Light Current ( $\mu\text{A}$ ) @ $E_v = 100$ lx using Fluorescent Light	Light Source Ratio (Incandescent Light to Fluorescent Light)	Standby Function	Output Logic (Dark $\rightarrow$ Bright)
TPS852	1.6 x 1.6 x 0.55(t)	2.7 to 5.5	27 to 54	1.2 x (typ.)	No	Low $\rightarrow$ High
TPS853	2.1 x 2.0 x 0.7(t)	2.2 to 5.5	37 to 74	1.2 x (typ.)	Yes	Low $\rightarrow$ High
TPS856	1.6 x 1.6 x 0.55(t)	1.8 to 5.5	40 to 80	1.0 x (typ.)	Yes	High $\rightarrow$ Low

## Ultra-Compact Surface-Mount Photointerrupter: TLP848

Ideal for optical zooming and AF lens position detection in digital cameras, digital video cameras and cellular phone cameras.

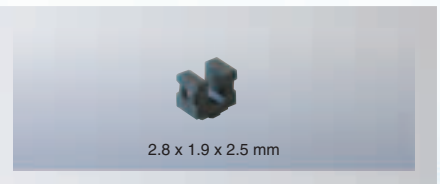

### ■ Features

- Ultra-compact surface-mount package
  - Size: 2.8 x 1.9 x 2.5 mm  $\Rightarrow$  50% in volume as compared with TLP846 (Toshiba existing product)
  - Detection gap with: 1.2 mm  $\Rightarrow$  Same as TLP846 (Toshiba existing product)
- High current transfer ratio:  $I_C/I_F = 3$  to 24 %

# TCS10/11 Digital-Output Magnetic Sensor Series

## Ideal for applications with open/close contacts

- Senses the magnetic flux density in the longitudinal field.
- Provides a digital output.
- Senses the S, N or both poles.

### ■ Dual-Pole (S and N) Magnetic Sensors

Item	Specification (TCS10DPU, TCS10DLU, TCS11DLU)
Power Supply	V <sub>CC</sub> = 2.3 to 3.6 V
Magnetic Flux Density	B <sub>ON</sub> = 1.8 mT (typ.) B <sub>OFF</sub> = 0.8 mT (typ.) Hysteresis (BH) = 1.0 mT (typ.)
Current Consumption (V <sub>CC</sub> = 2.3 to 2.7 V)	Average = 8.5 μA (typ.)
Output Configuration	Push-pull, open-drain (5-V-tolerant)

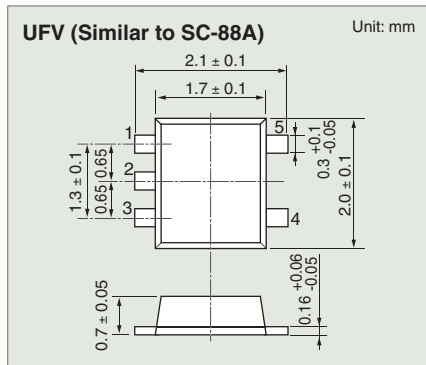

### Part Naming Schemes

**TCS 10 D P U**  
a b c d e

- a: Toshiba magnetic sensors
- b: Sensor characteristics
  - 10: Highly sensitive
  - 11: Highly sensitive and inverted output
- c: Polarity
  - S: S-pole sensing
  - N: N-pole sensing
  - D: S and N pole sensing
- d: Output configuration
  - P: Push-pull
  - L: Open-drain
- e: Packaging
  - U: UFV (Similar to SC-88A)

### ■ Application Data

Toshiba's magnetic sensors help improve system design flexibility due to their high sensitivity.

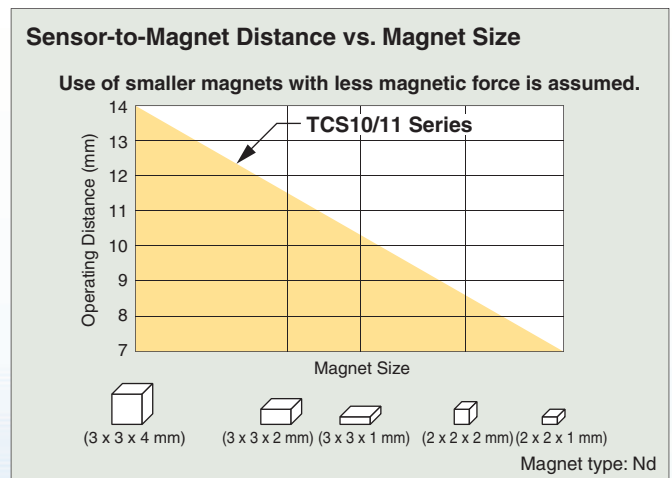
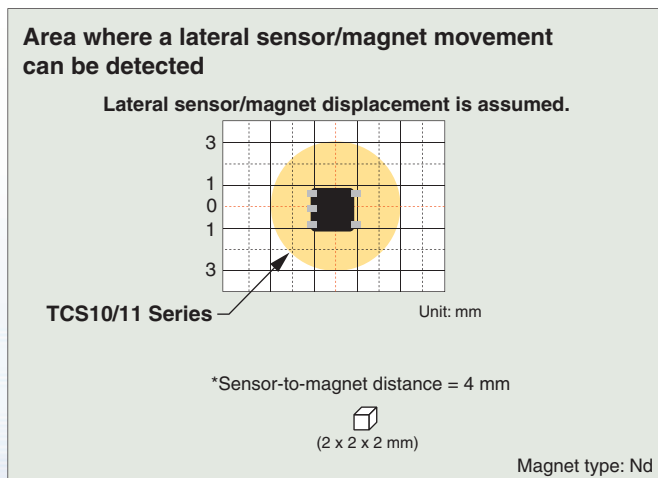

### ■ Product Offerings

Part Number	Sensed Pole	Output Configuration	Package
TCS10SPU	S	Push-pull	UFV (2.0 x 2.1 x 0.7 mm*) *Similar to SC-88A.
TCS10SLU		Open-drain	
TCS11SLU		Inverted output; open-drain	
TCS10NPU	N	Push-pull	
TCS10NLU		Open-drain	
TCS11NLU		Inverted output; open-drain	
TCS10DPU	S and N	Push-pull	
TCS10DLU		Open-drain	
TCS11DLU		Inverted output; open-drain	

# Ultra-Small, Low ON-Resistance Analog Switches

## TCFS201FC SPDT

- ON-resistance flatness:  
 $R_{ON\text{-flatness}} = 0.5 \Omega$  (typ.) @  $V_{CC} = 3.6 \text{ V}$
- ON-resistance:  $R_{ON} = 1.9 \Omega$  (typ.) @  $V_{CC} = 3.6 \text{ V}$
- Supply voltage:  $V_{CC} = 1.65$  to  $3.6 \text{ V}$
- Small package: CST6C  $1.15 \times 1.5 \times 0.38 \text{ mm}$

## TCFS101FC SPST

- ON-resistance flatness:  
 $R_{ON\text{-flatness}} = 0.3 \Omega$  (typ.) @  $V_{CC} = 3.6 \text{ V}$
- ON-resistance:  $R_{ON} = 0.8 \Omega$  (typ.) @  $V_{CC} = 3.6 \text{ V}$
- Supply voltage:  $V_{CC} = 1.65$  to  $3.6 \text{ V}$
- Small package: CST6C  $1.15 \times 1.5 \times 0.38 \text{ mm}$

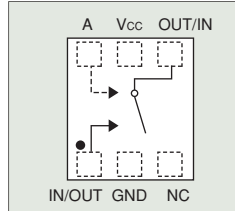
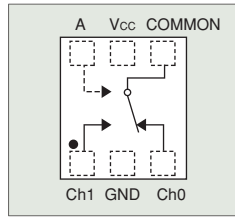

## Package Dimensions

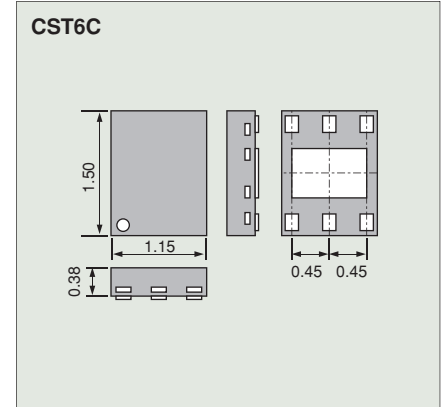

# ESD Protection Diodes

## Application Example

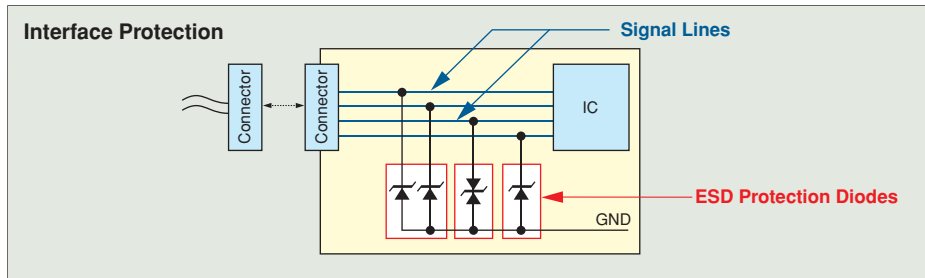

## DF2S6.8UFS: Low capacitance and high ESD protection

Ideal for high-speed signal lines (e.g., USB 2.0)

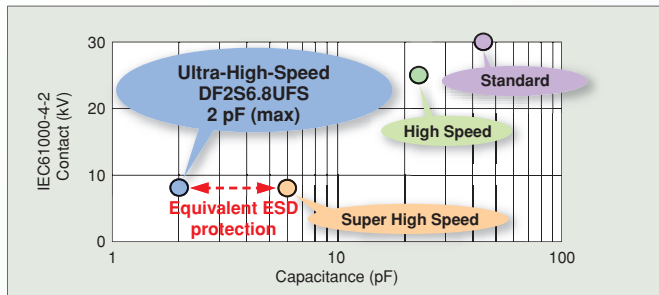

## General Specification

Characteristics (Symbol)	Rating (Test Condition)
Reverse stand-off voltage ( $V_{RWM}$ )	5.0 V (max)
Reverse voltage ( $V_R$ )	6.8 V (typ.) @ $I_R = 1 \text{ mA}$
Reverse current ( $I_R$ )	0.5 $\mu\text{A}$ (max) @ $V_{RWM} = 5 \text{ V}$
Diode capacitance ( $C_T$ )	2 pF (max) @ $V_R = 0 \text{ V}$ , $f = 1 \text{ MHz}$
Forward breakdown voltage	25 V (typ.)
ESD immunity	$\geq \pm 8 \text{ kV}$ @ IEC61000-4-2 (contact)
Package	fSC: $1.0 \times 0.6 \times 0.48 \text{ mm}$

## DF2B6.8FS: Bidirectional ESD protection diode

Ideal for audio signal line protection

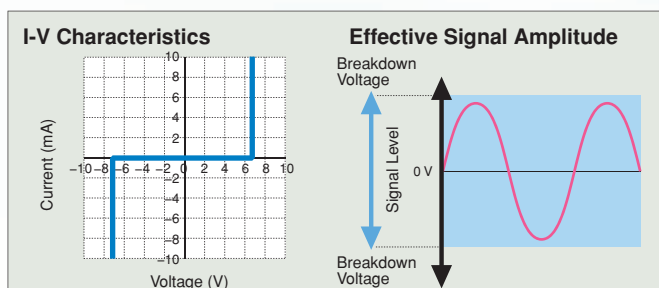

## General Specifications

Characteristics	Rating (Test Condition)
Breakdown voltage	6.8 V (typ.) @ $I_R = 5 \text{ mA}$
Reverse current	0.5 $\mu\text{A}$ (max) @ $V_R = 5 \text{ V}$
ESD immunity	$\geq \pm 8 \text{ kV}$ @ IEC61000-4-2 (contact)
Diode capacitance	15 pF (typ.) @ $V_R = 0 \text{ V}$ , $f = 1 \text{ MHz}$
Package	fSC: $1.0 \times 0.6 \times 0.48 \text{ mm}$

# Devices for Small Power Supplies: MOSFETs and CMOS LDO Regulators

## P-Channel MOSFET for Load Switch: SSM3J120TU

- 1.5-V operative
- Ultra-low ON-resistance P-channel MOSFET
- Absolute Maximum ratings
  - $V_{DSS} = -20\text{ V}$
  - $V_{GSS} = \pm 8\text{ V}$
  - $I_D = -4\text{ A}$
- Main characteristics
  - $R_{on} = 38\text{ m}\Omega$  max @  $V_{GS} = -4.0\text{ V}$
  - $R_{on} = 49\text{ m}\Omega$  max @  $V_{GS} = -2.5\text{ V}$
  - $R_{on} = 140\text{ m}\Omega$  max @  $V_{GS} = -1.5\text{ V}$
  - $C_{iss} = 1484\text{ pF}$  typ. @  $V_{DS} = -20\text{ V}$
- Small-Power UFM package: 2.0 x 2.1 x 0.7 mm

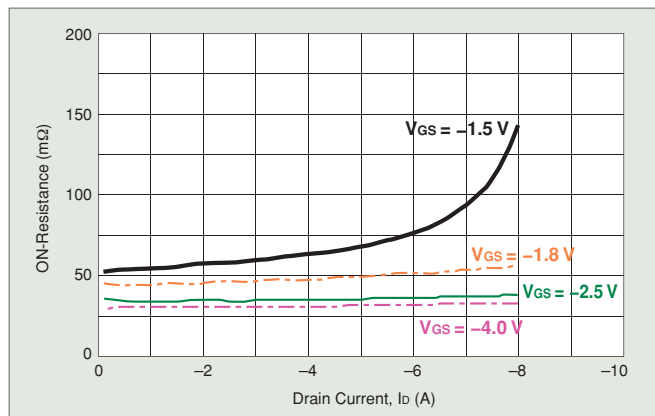

## N-Channel MOSFET for Load Switch: SSM3K123TU

- 1.5-V operative
- Ultra-low ON-resistance N-channel MOSFET
- Absolute Maximum ratings
  - $V_{DSS} = 20\text{ V}$
  - $V_{GSS} = \pm 10\text{ V}$
  - $I_D = 4.2\text{ A}$
- Main characteristics
  - $R_{on} = 28\text{ m}\Omega$  max @  $V_{GS} = 4.0\text{ V}$
  - $R_{on} = 32\text{ m}\Omega$  max @  $V_{GS} = 2.5\text{ V}$
  - $R_{on} = 66\text{ m}\Omega$  max @  $V_{GS} = 1.5\text{ V}$
  - $C_{iss} = 1010\text{ pF}$  typ. @  $V_{DS} = 10\text{ V}$
- Small-power UFM package: 2.0 x 2.1 x 0.7 mm

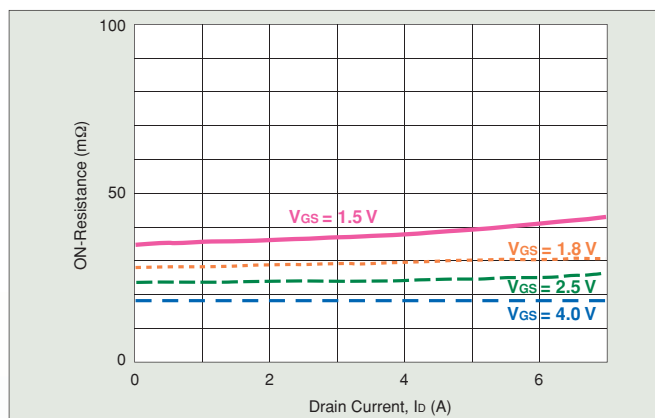

## CMOS LDO Regulators in a Tiny Package: TCR5SCxxFE

- Output current:  $I_{OUT}(\text{max}) = 150\text{ mA}$
- Low dropout voltage:  $V_{drop} = 90\text{ mV}$  (typ.) @  $I_{OUT} = 50\text{ mA}$ , TCR5SC25FE
- Base current:  $I_B$  (typ.) =  $32\text{ }\mu\text{A}$  @  $I_{OUT} = 0\text{ mA}$
- Ripple rejection: R.R. (typ.) =  $70\text{ dB}$  @  $f = 1\text{ kHz}$
- Output noise voltage:  $V_{NO}(\text{typ.}) = 100\text{ }\mu\text{Vrms}$  @  $I_{OUT} = 10\text{ mA}$
- Available with an output voltage of 1.5 V to 3.6 V in 0.1-V steps
- Overcurrent protection
- Small package: ESV

### Package

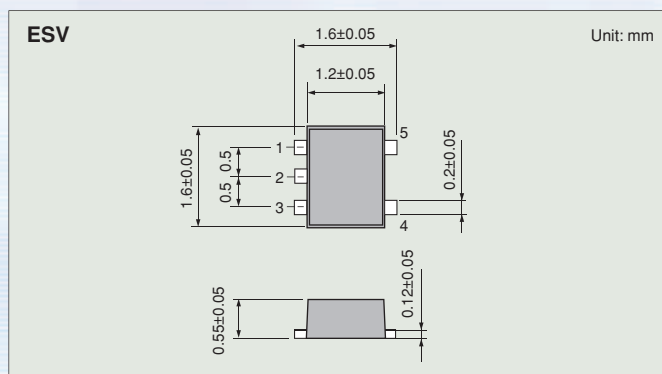

### Pin Configuration

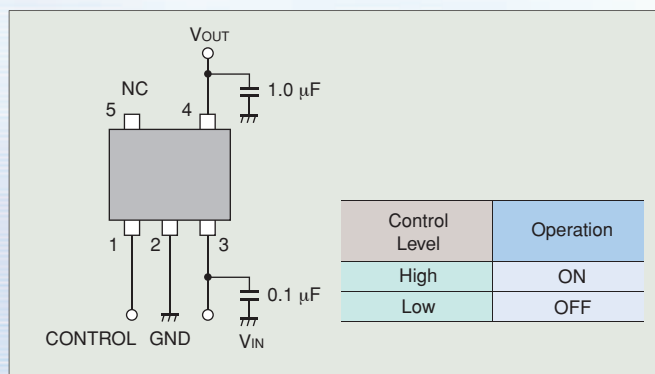

**Toshiba America Electronic Components, Inc.**

**Headquarters-Irvine, CA**  
19900 MacArthur Boulevard,  
Suite 400, Irvine, CA 92612, U.S.A.  
Tel: (949)623-2900 Fax: (949)474-1330

**Buffalo Grove (Chicago)**  
2150 E. Lake Cook Road, Suite 310,  
Buffalo Grove, IL 60089, U.S.A.  
Tel: (847)484-2400 Fax: (847)541-7287

**Duluth, GA (Atlanta)**  
3700 Crestwood Pkwy, #160,  
Duluth, GA 30096, U.S.A.  
Tel: (770)931-3363 Fax: (770)931-7602

**Raleigh, NC**  
3120 Highwoods Blvd., #108, Raleigh,  
NC 27604, U.S.A.  
Tel: (919)859-2800 Fax: (919)859-2898

**Richardson, TX (Dallas)**  
777 East Campbell Rd., #650, Richardson,  
TX 75081, U.S.A.  
Tel: (972)480-0470 Fax: (972)235-4114

**San Jose Engineering Center, CA**  
2590 Orchard Parkway San Jose,  
CA 95131, U.S.A.  
Tel: (408)526-2400 Fax: (408)526-2410

**Wixom (Detroit)**  
48680 Alpha Drive, Suite 120, Wixom,  
MI 48393 U.S.A.  
Tel: (248)347-2607 Fax: (248)347-2602

**Toshiba Electronics do Brasil Ltda.**  
Rua Alfonso Celso, 552-8 andar, C.J. 81,  
Vila Mariana, Cep 04119-002 Sa˜o Paulo SP, Brasil  
Tel: (011)5576-6619 Fax: (011)5576-6607

**Toshiba India Private Ltd.**  
6F DR. Gopal Das Bhawan 28,  
Barakhamba Road, New Delhi, 110001, India  
Tel: (011)2331-8422 Fax: (011)2371-4603

**Toshiba Electronics Europe GmbH**

**Düsseldorf Head Office**  
Hansaallee 181, D-40549 Düsseldorf,  
Germany  
Tel: (0211)5296-0 Fax: (0211)5296-400

**München Office**  
Büro München Hofmannstrasse 52,  
D-81379, München, Germany  
Tel: (089)748595-0 Fax: (089)748595-42

**France Branch**  
Les Jardins du Golf 6 rue de Rome F-93561,  
Rosny-Sous-Bois, Cedex, France  
Tel: (1)48-12-48-12 Fax: (1)48-94-51-15

**Italy Branch**  
Centro Direzionale Colleoni,  
Palazzo Perseo 3,  
I-20041 Agrate Brianza, (Milan), Italy  
Tel: (039)68701 Fax: (039)6870205

**Spain Branch**  
Parque Empresarial, San Fernando, Edificio Europa,  
1ª Planta, E-28831 Madrid, Spain  
Tel: (91)660-6798 Fax: (91)660-6799

**U.K. Branch**  
Delta House, The Crescent Southwood Business Park  
Farnborough, Hampshire GU14 0NL, U.K.  
Tel: (0870)060-2370 Fax: (01252)53-0250

**Sweden Branch**  
Gustavslundsvägen 18, 5th Floor,  
S-167 15 Bromma, Sweden  
Tel: (08)704-0900 Fax: (08)80-8459

**Toshiba Electronics Asia (Singapore) Pte. Ltd.**  
438B Alexandra Road, #06-08/12 Alexandra  
Technopark, Singapore 119968  
Tel: (6278)5252 Fax: (6271)5155

**Toshiba Electronics Service (Thailand) Co., Ltd.**  
135 Moo 5, Bangkok Industrial Park, Tivanon Road,  
Pathumthani, 12000, Thailand  
Tel: (02)501-1635 Fax: (02)501-1638

**Toshiba Electronics Trading (Malaysia) Sdn. Bhd.**

**Kuala Lumpur Head Office**  
Suite W1203, Wisma Consplant, No.2,  
Jalan SS 16/4, Subang Jaya, 47500 Petaling Jaya,  
Selangor Darul Ehsan, Malaysia  
Tel: (03)5631-6311 Fax: (03)5631-6307

**Penang Office**  
Suite 13-1, 13th Floor, Menara Penang Garden,  
42-A, Jalan Sultan Ahmad Shah,  
10050 Penang, Malaysia  
Tel: (04)226-8523 Fax: (04)226-8515

**Toshiba Electronics Philippines, Inc.**  
26th Floor, Citibank Tower, Valero Street, Makati,  
Manila, Philippines  
Tel: (02)750-5510 Fax: (02)750-5511

**Toshiba Electronics Asia, Ltd.**

**Hong Kong Head Office**  
Level 11, Tower 2, Grand Century Place, No.193,  
Prince Edward Road West, Mongkok, Kowloon, Hong Kong  
Tel: 2375-6111 Fax: 2375-0969

**Beijing Office**  
Room 814, Beijing Fortune Building, No.5 Dong San Huan Bei-Lu,  
Chao Yang District, Beijing, 100004, China  
Tel: (010)6590-8796 Fax: (010)6590-8791

**Chengdu Office**  
Room 2508A, 2 Zongfu Street, Times Plaza,  
Chengdu 610016 Sichuan, China  
Tel: (028)8675-1773 Fax: (028)8675-1065

**Qingdao Office**  
Room 4(D-E), 24F, International Financial Center,  
59 Xiang Gang Zhong Road, Qingdao 266071, Shandong, China  
Tel: (532)8579-3328 Fax: (532)8579-3329

**Toshiba Electronics Shenzhen Co., Ltd.**  
28/F, Excellence Times Square Building, 4068 Yi Tian Road,  
Fu Tian District, Shenzhen 518048, China  
Tel: (0755)2399-6897 Fax: (0755)2399-5573

**Toshiba Electronics (Shanghai) Co., Ltd.**

**Shanghai Head Office**  
11F, HSBC Tower, 1000 Lujiazui Ring Road,  
Pudong New Area, Shanghai 200120, China  
Tel: (021)6841-0666 Fax: (021)6841-5002

**Hangzhou Office**  
502 JiaHua International Business Center,  
No.28 HangDa Road, Hangzhou, 310007, China  
Tel: (0571)8717-5004 Fax: (0571)8717-5013

**Nanjing Office**  
23F Shiji Shangmao Plaza,  
No.49 Zhong Shan South Road, Nanjing, 210005, China  
Tel: (025)8689-0070 Fax: (025)8689-0125

**Toshiba Electronics (Dalian) Co., Ltd.**  
14/F, Senmao Building, 147, Zhongshan Road,  
Xigang Dist., Dalian, 116011, China  
Tel: (0411)8368-6882 Fax: (0411)8369-0822

**Tsurong Xiamen Xiangyu Trading Co., Ltd.**  
14G, International Bank BLDG., No.8 Lujiang Road,  
Xiamen, 361001, China  
Tel: (0592)226-1398 Fax: (0592)226-1399

**Toshiba Electronics Korea Corporation**

**Seoul Head Office**  
891, Samsung Life Insurance Daechi Tower 20F, Daechi-dong,  
Gangnam-gu, Seoul, 135-738, Korea  
Tel: (02)3484-4334 Fax: (02)3484-4302

**Daegu Office**  
16F, Hosoo Bldg. 50-3 Dongin-Dong 2(i)-GA,  
Jung-gu, Daegu, Korea 700-732  
Tel: (053)428-7610 Fax: (053)428-7617

**Toshiba Electronics Taiwan Corporation**

**Taipei Head Office**  
10F, No.10, Sec.3, Minsheng E.Rd., Taipei City 10480, Taiwan  
Tel: (02)2508-9988 Fax: (02)2508-9999

**Kaohsiung Office**  
16F-A, Chung-Cheng Building, 2, Chung-Cheng 3Road,  
Kaohsiung, 80027, Taiwan  
Tel: (07)237-0826 Fax: (07)236-0046

The information contained herein is subject to change without notice. 021023\_D

TOSHIBA is continually working to improve the quality and reliability of its products. Nevertheless, semiconductor devices in general can malfunction or fail due to their inherent electrical sensitivity and vulnerability to physical stress. It is the responsibility of the buyer, when utilizing TOSHIBA products, to comply with the standards of safety in making a safe design for the entire system, and to avoid situations in which a malfunction or failure of such TOSHIBA products could cause loss of human life, bodily injury or damage to property, in developing your designs, please ensure that TOSHIBA products are used within specified operating ranges as set forth in the most recent TOSHIBA products specifications. Also, please keep in mind the precautions and conditions set forth in the "Handling Guide for Semiconductor Devices," or "TOSHIBA Semiconductor Reliability Handbook" etc. 021023\_A

The TOSHIBA products listed in this document are intended for usage in general electronics applications (computer, personal equipment, office equipment, measuring equipment, industrial robotics, domestic appliances, etc.). These TOSHIBA products are neither intended nor warranted for usage in equipment that requires extraordinarily high quality and/or reliability or a malfunction or failure of which may cause loss of human life or bodily injury ("Unintended Usage"). Unintended Usage include atomic energy control instruments, airplane or spaceship instruments, transportation instruments, traffic signal instruments, combustion control instruments, medical instruments, all types of safety devices, etc. Unintended Usage of TOSHIBA products listed in this document shall be made at the customer's own risk. 021023\_B

The products described in this document shall not be used or embedded to any downstream products of which manufacture, use and/or sale are prohibited under any applicable laws and regulations. 060106\_Q

The information contained herein is presented only as a guide for the applications of our products. No responsibility is assumed by TOSHIBA for any infringements of patents or other rights of the third parties which may result from its use. No license is granted by implication or otherwise under any patents or other rights of TOSHIBA or the third parties. 070122\_C

GaAs(Gallium Arsenide) is used in some of the products. The dust or vapor is harmful to the human body. Do not break, cut, crush or dissolve chemically. 021023\_J

Please contact your sales representative for product-by-product details in this document regarding RoHS compatibility. Please use these products in this document in compliance with all applicable laws and regulations that regulate the inclusion or use of controlled substances. Toshiba assumes no liability for damage or losses occurring as a result of noncompliance with applicable laws and regulations. 060819\_Z

The products described in this document may include products subject to the foreign exchange and foreign trade control laws. 060925\_F

The products described in this document may contain components made in the United States and subject to export control of the U.S. authorities. Diversion contrary to the U.S. law is prohibited. 021023\_H

# TOSHIBA

**TOSHIBA CORPORATION**  
Semiconductor Company

Website: <http://www.semicon.toshiba.co.jp/eng>

©2008 TOSHIBA CORPORATION

Previous edition: SCE0008G  
2008-9(1k)SO-DQ