

Quad Operational Amplifiers

TAA 4762
TAA 4765

Bipolar IC

Features

- Wide common-mode range
- Large supply voltage range
- Comprehensive protection against destruction
- High output current
- Large control range
- Internal frequency compensation
- Wide temperature range (TAA 4762 A)
- Open collector output

Applications

- Amplifier
- Comparator
- Level converter
- Driver

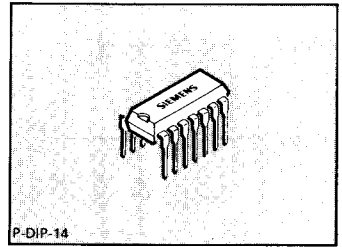

Pin Configuration (top view)

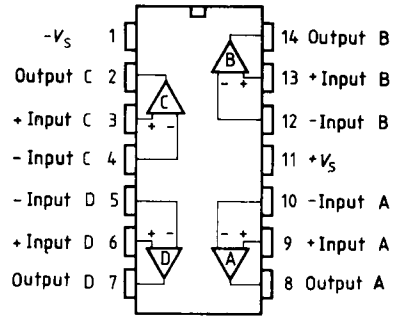

Type	Ordering Code	Package
☒ TAA 4762 A	Q67000-A2502	P-DIP-14
☒ TAA 4765 A	Q67000-A1033	P-DIP-14

These op amps are particularly economic and versatile. Owing to their excellent performance qualities, they are well suited for a wide scope of applications, as in control engineering, automotive electronics, AF circuits, analog computers, etc.

Circuit Diagram of one Op Amp

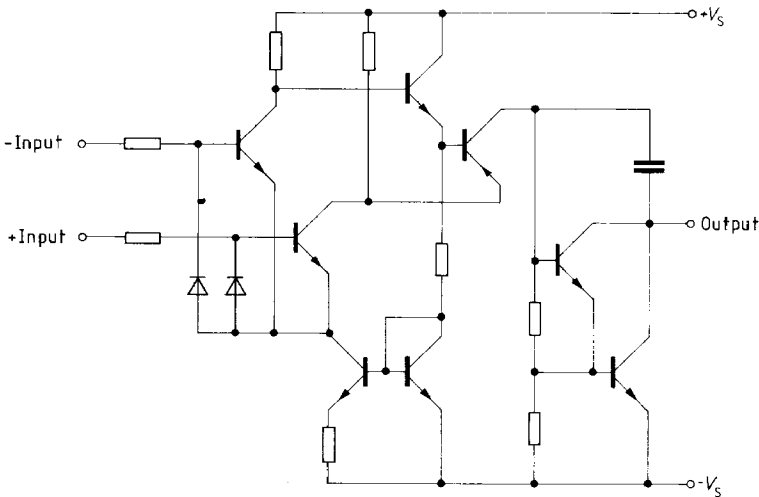

Absolute Maximum Ratings (TAA 4762, TAA 4765)

Parameter	Symbol	Limit Values	Unit
Supply voltage	V_S	± 15	V
Output current	I_Q	70	mA
Differential input voltage	V_{ID}	$\pm V_S$	V
Junction temperature	T_j	150	$^{\circ}\text{C}$
Storage temperature range	T_{stg}	-55 to 125	$^{\circ}\text{C}$
Thermal resistance system – air	$R_{th SA}$	80	K/W

Operating Range (TAA 4762, TAA 4765)

Parameter	Symbol	Limit Values	Unit
Supply voltage	V_S	± 2 to ± 15	V
Ambient temperature	T_A	-55 to 125	$^{\circ}\text{C}$
	T_A	-25 to 85	$^{\circ}\text{C}$

Characteristics (TAA 4762)

$V_S = \pm 5 \text{ V}$ to $\pm 15 \text{ V}$; $R_L = 2 \text{ k}\Omega$, unless otherwise specified

Parameter	Symbol	Limit Values $T_A = 25^\circ\text{C}$			Limit Values $T_A = -55$ to 125°C		Unit
		min.	typ.	max.	min.	max.	
Open-loop supply current consumption, total	I_S		1	3		3	mA
Input offset voltage, $R_G = 50 \Omega$	V_{IO}	-4			-6	6	mV
Input offset current	I_{IO}	-100	± 50	100	-300	300	nA
Input current	I_I		0.3	0.7		1.0	μA
Control range $V_S = \pm 15 \text{ V}$ $R_L = 620 \Omega$, $V_S = \pm 15 \text{ V}$	$V_{Q\text{pp}}$ $V_{Q\text{pp}}$	14.9 14.9		-14 -12.5	14.8 14.8	-14 -12	V V
Input impedance, $f = 1 \text{ kHz}$	Z_I		200				k Ω
Open-loop voltage gain $f = 100 \text{ Hz}$ $R_L = 10 \Omega$, $f = 100 \text{ Hz}$	G_{V0} G_{V0}	85	87 92		80		dB dB
Output reverse current	I_{QR}			1		5	μA
Common-mode input voltage range	V_{IC}	$-V_2+2$		V_S-2	$-V_S+3$	V_S-3	V
Common-mode rejection	k_{CMR}	80	85		75		dB
Supply voltage rejection, $G_V = 100$	k_{SVR}		25	100		100	$\mu\text{V/V}$
Temperature coefficient of V_{IO} $R_G = 50 \Omega$	α_{VIO}		1	15		25	$\mu\text{V/K}$
Temperature coefficient of I_{IO} $R_G = 50 \Omega$	α_{IIO}		0.3	1.5		1.5	nA/K
Noise voltage (in acc. with DIN 45405, referred to input $R_S = 2.5 \Omega$)	V_n		3				μV
Output saturation voltage $I_Q = 10 \text{ mA}$	V_{Qsat}			1			V
Slew rate for non-inverting operation ¹⁾	SR		0.5				V/ μs
Slew rate for inverting operation ¹⁾	SR		0.5				V/ μs

Characteristics (TAA 4762)

$V_S = \pm 2 \text{ V}$, $R_L = 2 \text{ k}\Omega$

Input offset voltage, $R_G = 50 \Omega$	V_{IO}	-4		4	-6	6	mV
Input offset current	I_{IO}	-70		70	-200	200	nA
Input current	I_I		0.2	0.5		0.8	μA
Open-loop voltage gain; $f = 100 \text{ Hz}$	G_{V0}	80			75		dB

¹⁾ For the relationship between power bandwidth and slew rate refer to "Introduction to Operational Amplifiers"

Characteristics (TAA 4765)
 $V_S = \pm 5 \text{ V}$ to $\pm 15 \text{ V}$; $R_L = 2 \text{ k}\Omega$, unless otherwise specified

Parameter	Symbol	Limit Values $T_A = 25^\circ\text{C}$			Limit Values $T_A = -25$ to 85°C		Unit
		min.	typ.	max.	min.	max.	
Open-loop supply current consumption, total	I_S		1	3		3	mA
Input offset voltage, $R_G = 50 \Omega$	V_{IO}	-5.5		5.5	-7	7	mV
Input offset current	I_{IO}	-200	± 80	200	-300	300	nA
Input current	I_I		0.5	0.8		1.0	μA
Control range $V_S = \pm 15 \text{ V}$	$V_{O\text{pp}}$	14.9		-14	14.8	-14	V
$R_L = 620 \Omega$, $V_S = \pm 15 \text{ V}$	$V_{O\text{pp}}$	14.9		-12.5	14.8	-12	V
Input impedance, $f = 1 \text{ kHz}$	Z_I		200				k Ω
Open-loop voltage gain $f = 100 \text{ Hz}$	G_{V0}	80	85		80		dB
$R_L = 10 \text{ k}\Omega$, $f = 100 \text{ Hz}$	G_{V0}		90				dB
Output reverse current	I_{QR}			10		20	μA
Common-mode input voltage range	V_{IC}	$-V_S+2$		V_S-2	$-V_S+3$	V_S-3	V
Common-mode rejection	k_{CMR}	75	83		75		dB
Supply voltage rejection, $G_V = 100$	k_{SVR}		25	100		100	$\mu\text{V/V}$
Temperature coefficient of V_{IO} $R_G = 50 \Omega$	α_{VIO}		1	15		25	$\mu\text{V/K}$
Temperature coefficient of I_{IO} $R_G = 50 \Omega$	α_{IIO}		0.3				nA/K
Noise voltage (in acc. with DIN 45405, referred to input $R_S = 2.5 \Omega$)	V_n		3				μV
Output saturation voltage $I_O = 10 \text{ mA}$	V_{Qsat}			1			V
Slew rate for non-inverting operation ¹⁾	SR		0.5				V/ μs
Slew rate for inverting operation ¹⁾	SR		0.5				V/ μs

Characteristics (TAA 4765)
 $V_S = \pm 2 \text{ V}$, $R_L = 2 \text{ k}\Omega$

Input offset voltage, $R_G = 50 \Omega$	V_{IO}	-6		6	-7.5	7.5	mV
Input offset current	I_{IO}	-150		150	-200	200	nA
Input current	I_I		0.2	0.6		0.8	μA
Open-loop voltage gain; $f = 100 \text{ Hz}$	G_{V0}	75			75		dB

¹⁾ For the relationship between power bandwidth and slew rate refer to "Introduction to Operational Amplifiers"