

**QUAD 2-PORT REGISTER**

- FULLY POSITIVE EDGE-TRIGGERED OPERATION
- SELECT FROM TWO DATA SOURCES
- INPUT CLAMP DIODES LIMIT HIGH SPEED TERMINATION EFFECTS

**DESCRIPTION**

The T74LS399 is a Quad 2-Port Register. It is logical equivalent to a quad 2-input multiplexer followed by a 4-bit edge-triggered register. The selected data is transferred to the output register on the LOW-to-HIGH transition of the Clock input.

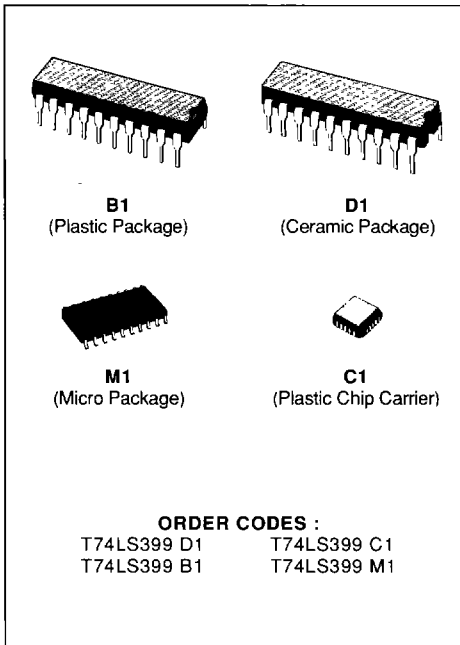

**PIN NAMES**

S	COMMON SELECT INPUT
CP	CLOCK (Active HIGH going edge) INPUT
I <sub>0a</sub> -I <sub>0d</sub>	DATA INPUT FROM SOURCE 0
I <sub>1a</sub> -I <sub>1d</sub>	DATA INPUT FROM SOURCE 1
Q <sub>a</sub> -Q <sub>d</sub>	REGISTER TRUE OUTPUTS
Q <sub>a</sub> -Q <sub>d</sub>	REGISTER COMPLEMENTARY OUTPUTS

**PIN CONNECTION (top view)**

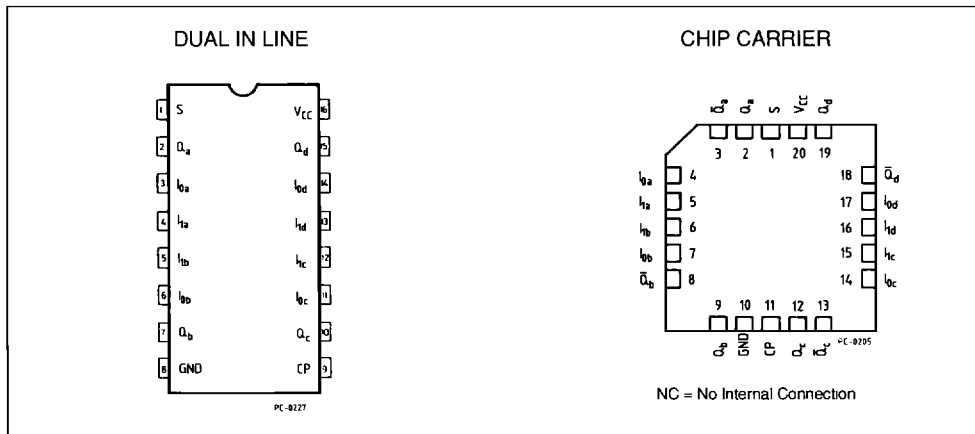

## T74LS399

### FUNCTIONAL DESCRIPTION

This high speed Quad 2-Port Register selects four bits of data from two sources (Port) under the control of a Common Select Input (S). The 4-bit Output Register where selected data are transferred is synchronous with the LOW-to-HIGH transition of the

Clock input (CP). The 4-bit RS type output register is fully edge-triggered. Predictable operation is assured if Data inputs (I) and select inputs (S) are kept stable only a set-up time prior to and hold time after the LOW-to-HIGH transition of the Clock input.

### TRUTH TABLE

Inputs			Outputs
S	I <sub>0</sub>	I <sub>1</sub>	Q
l	l	X	L
l	h	X	H
h	X	l	L
h	X	h	H

L = LOW Voltage Level  
 H = HIGH Voltage Level  
 X = Don't care  
 l = LOW Voltage Level one set-up Time Prior to the LOW-to-HIGH Clock Transition  
 h = High Voltage Level one set-up Time Prior to the LOW-to-HIGH Clock Transition

### ABSOLUTE MAXIMUM RATINGS

Symbol	Parameter	Value	Unit
V <sub>CC</sub>	Supply Voltage	- 0.5 to 7	V
V <sub>I</sub>	Input Voltage, Applied to Input	- 0.5 to 15	V
V <sub>O</sub>	Output Voltage, Applied to Output	0 to 10	V
I <sub>I</sub>	Input Current, Into Inputs	- 30 to 5	mA
I <sub>O</sub>	Output Current, Into Outputs	50	mA

Stresses in excess of those listed under "Absolute Maximum Ratings" may cause permanent damage to the device. This is a stress rating only and functional operation of the device at these or any other conditions in excess of those indicated in the operational sections of this specification is not implied. Exposure to absolute maximum rating conditions for extended periods may affect device reliability.

### GUARANTEED OPERATING RANGE

Part Numbers	Supply Voltage			Temperature
	Min.	Typ.	Max.	
T74LS399XX	4.75 V	5.0 V	5.25 V	0 °C to + 70 °C

XX = package type.

## DC CHARACTERISTICS OVER OPERATING TEMPERATURE RANGE

Symbol	Parameter	Limits			Test Condition (note 1)	Unit	
		Min.	Typ. (*)	Max.			
V <sub>IH</sub>	Input HIGH Voltage	2.0			Guaranteed Input HIGH Voltage for all Inputs	V	
V <sub>IL</sub>	Input LOW Voltage			0.8	Guaranteed Input LOW Voltage for all Inputs	V	
V <sub>CD</sub>	Input Clamp Diode Voltage		- 0.65	- 1.5	V <sub>CC</sub> = MIN, I <sub>IN</sub> = -18 mA	V	
V <sub>OH</sub>	Output HIGH Voltage	2.7	3.4		V <sub>CC</sub> = MIN, I <sub>OH</sub> = - 400 $\mu$ A V <sub>IN</sub> = V <sub>IH</sub> or V <sub>IL</sub> per Truth Table	V	
V <sub>OL</sub>	Output LOW Voltage		0.25	0.4	I <sub>OL</sub> = 4.0 mA	V <sub>CC</sub> = MIN V <sub>IN</sub> = V <sub>IH</sub> or V <sub>IL</sub> per Truth Table	V
			0.35	0.5	I <sub>OL</sub> = 8.0 mA		V
I <sub>IH</sub>	Input HIGH Current			20	V <sub>CC</sub> = MAX, V <sub>IN</sub> = 2.7 V	$\mu$ A	
				40	V <sub>CC</sub> = MAX, V <sub>IN</sub> = 7.0 V		
I <sub>IL</sub>	Input LOW Current			- 0.4	V <sub>CC</sub> = MAX, V <sub>IN</sub> = 0.4 V	mA	
I <sub>OS</sub>	Output Short Circuit Current (note 2)	- 20		- 100	V <sub>CC</sub> = MAX, V <sub>OUT</sub> = 0 V	mA	
I <sub>CC</sub>	Supply Current			13	V <sub>CC</sub> = MAX	mA	

Notes : 1. For conditions shown as MIN or MAX, use the appropriate value specified under guaranteed operating ranges.  
2. Not more than one output should be shorted at a time.  
(\*) Typical values are at V<sub>CC</sub> = 5.0 V, T<sub>A</sub> = 25 °C.

AC CHARACTERISTICS : T<sub>A</sub> = 25 °C

Symbol	Parameter	Limits			Test Conditions	Unit
		Min.	Typ.	Max.		
t <sub>PLH</sub> t <sub>PHL</sub>	Propagation Delay, Clock to Output Q		18 21	27 32	V <sub>CC</sub> = 5.0 V C <sub>L</sub> = 15 pF	ns

AC SET-UP REQUIREMENTS : T<sub>A</sub> = 25 °C

Symbol	Parameter	Limits			Test Conditions	Unit
		Min.	Typ.	Max.		
t <sub>W</sub>	Clock Pulse Width	20			V <sub>CC</sub> = 5.0 V	ns
t <sub>s</sub>	Data Set-up Time	25				ns
t <sub>s</sub>	Select Set-up Time	45				ns
t <sub>h</sub>	Hold Time, Any Input	0				ns

## DEFINITION OF TERMS

SET-UP TIME (t<sub>s</sub>) is defined as the minimum time required for the correct logic level to be present at the logic input prior to the clock transition from LOW to HIGH in order to be recognized and transferred to the outputs.

HOLD TIME (t<sub>h</sub>) is defined as the minimum time fol-

lowing the clock transition from LOW to HIGH that the logic level must be maintained at the input in order to ensure continued recognition. A negative HOLD TIME indicates that the correct logic level may be released prior to the clock transition from LOW to HIGH and still be recognized.

T74LS399

AC WAVEFORMS

Figure 1 .

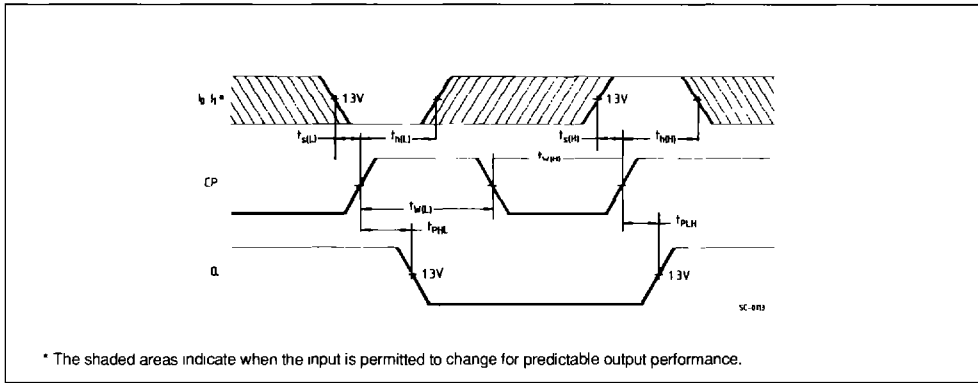

Figure 2 .

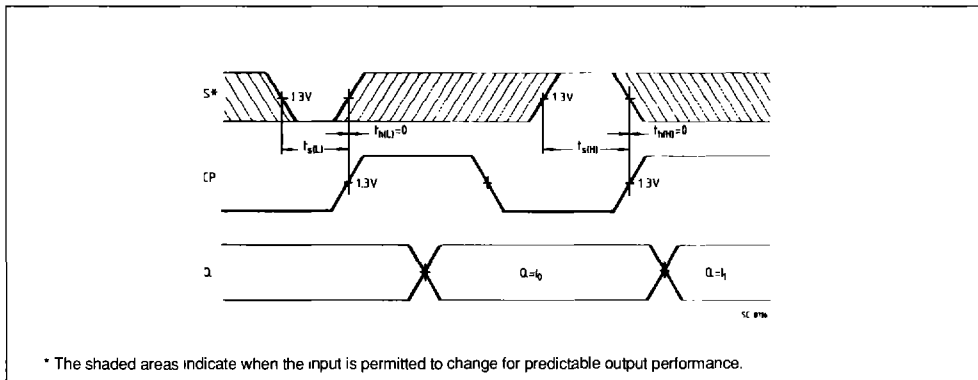

Figure 3 .

