



Features

- Single 3-V Supply Voltage
- High Power-added Efficient Power Amplifier (P_{out} Typically 23 dBm)
- Ramp-controlled Output Power
- Current-saving Standby Mode
- Few External Components
- HP-VFQFP-N16 Package

Electrostatic sensitive device.
Observe precautions for handling.



Description

The T7023 is a monolithic SiGe power amplifier. It is especially designed for operation in TDMA systems like Bluetooth and WDCT.

Due to the ramp-control feature and a very low quiescent current, an external switch transistor for V_S is not required.

Figure 1. Block Diagram

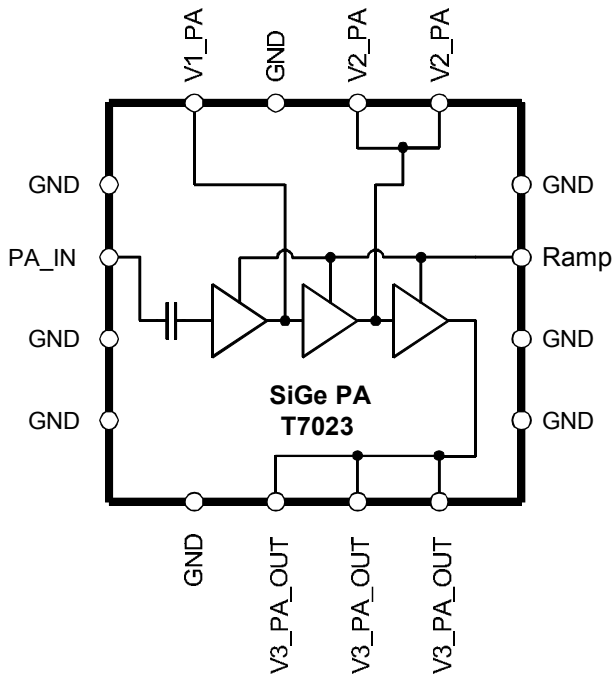

Bluetooth™ 2.4-GHz Power Amplifier

T7023



Pin Configuration

Figure 2. Pinning HP-VFQFP-N16

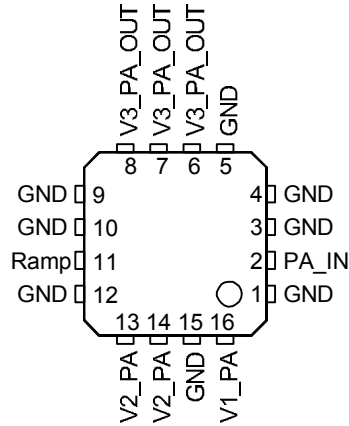

Pin Description

Pin	Symbol	Function
1	GND	Ground
2	PA_IN	Power amplifier input
3	GND	Ground
4	GND	Ground
5	GND	Ground
6	V3_PA_OUT	Inductor to power supply and matching network for power amplifier output
7	V3_PA_OUT	Inductor to power supply and matching network for power amplifier output
8	V3_PA_OUT	Inductor to power supply and matching network for power amplifier output
9	GND	Ground
10	GND	Ground
11	RAMP	Power ramping control input
12	GND	Ground
13	V2_PA	Inductor to power supply for power amplifier
14	V2_PA	Inductor to power supply for power amplifier
15	GND	Ground
16	V1_PA	Supply voltage for power amplifier
Slug	GND	Ground

Absolute Maximum Ratings

All voltages are referred to ground (Pins GND and slug), no RF

Parameters	Symbol	Value	Unit
Supply voltage Pins V1_PA, V2_PA and V3_PA_OUT	V_S	6	V
Junction temperature	T_j	150	°C
Storage temperature	T_{stg}	-40 to +125	°C
RF input power PA	P_{inPA}	10 dBm	dBm

Thermal Resistance

Parameters	Symbol	Value	Unit
Junction ambient HP-VFQFP-N16, Slug soldered on pcb	R_{thJA}	40	K/W

Operating Range

All voltages are referred to ground (Pins GND and slug). Power supply points are V1_PA, V2_PA, V3_PA_OUT. The following table represents the sum of all supply currents depending on the TX mode.

Parameters	Symbol	Min.	Typ.	Max.	Unit
Supply voltage Pins V1_PA, V2_PA and V3_PA_OUT	V_S	2.7	3.0	4.6	V
Supply current	I_S		165		mA
Standby current	$I_{S_standby}$		10		µA
Ambient temperature	T_{amb}	-25	+25	+70	°C

Electrical Characteristics

Test conditions (unless otherwise specified): $V_S = 3.0\text{ V}$, $T_{\text{amb}} = 25^\circ\text{C}$

Parameters	Test Conditions	Symbol	Min.	Typ.	Max.	Unit
Power Amplifier ⁽¹⁾						
Supply voltage	Pins V1_PA, V2_PA and V3_PA_OUT	V_S	2.7	3.0	4.6	V
Supply current	TX	I_{S_TX}		165		mA
	Standby	$I_{S_standby}$			10	μA
Frequency range	TX	f	2.4		2.5	GHz
Gain-control range	TX	ΔGp	60	42		dB
Power gain maximum	TX Pin PA_IN to V3_PA_OUT	Gp	28	30	33	dB
Power gain minimum	TX Pin PA_IN to V3_PA_OUT	Gp	-40		-17	dB
Ramping voltage maximum	TX, power gain (maximum) Pin RAMP	$V_{\text{RAMP max}}$	1.7	1.75	1.83	V
Ramping voltage minimum	TX, power gain (minimum) Pin RAMP	$V_{\text{RAMP min}}$		0.1		V
Ramping current maximum	$V = 1.75\text{ V}$				0.5	mA
Power-added efficiency	TX	PAE	35	42		%
Saturated output power	TX, input power = 0 dBm referred to Pins V3_PA_OUT	P_{sat}	22	23	24	dBm
Input matching ⁽²⁾	TX, Pin PA_IN	Load VSWR		<1.5:1		
Output matching ⁽²⁾	TX, Pin V3_PA_OUT	Load VSWR		<1.5:1		
Harmonics at $P_{\text{sat}} = 23\text{ dBm}$	TX, Pin V3_PA_OUT	$2 f_0$			-30	dBc
Harmonics at $P_{\text{sat}} = 23\text{ dBm}$	TX, Pin V3_PA_OUT	$3 f_0$			-30	dBc

- Notes: 1. Power amplifier shall be unconditionally stable, maximum duty cycle 100%, true CW operation, maximum load mismatch and duration: VSWR 10:1 (all phases) 10 s, $Z_G = 50\ \Omega$.
 2. With external matching network, load impedance $50\ \Omega$

Typical Operating Characteristics

Figure 3. Output Power and PAE versus Supply Voltage

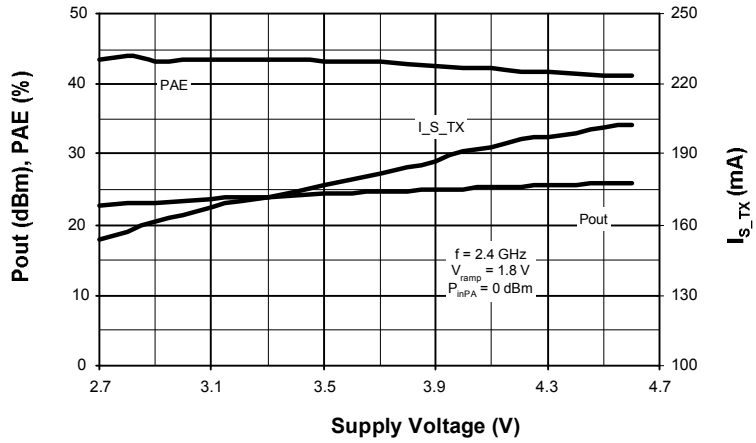

Figure 4. Output Power and PAE versus Frequency

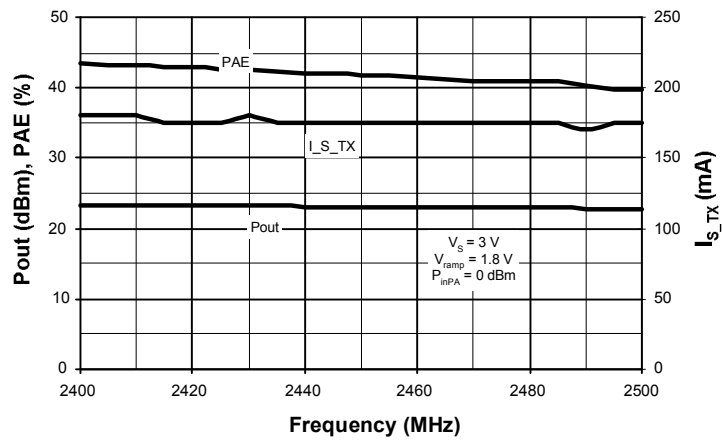

Figure 5. Output Power and PAE versus Ramp Voltage

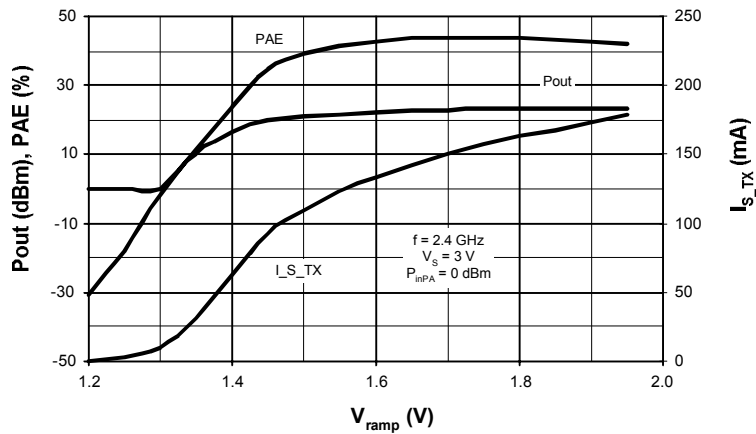

Figure 6. Output Power and PAE versus Input Power

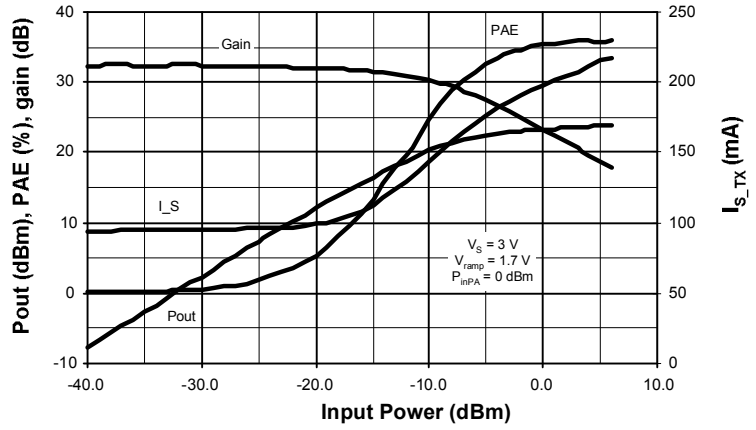

Figure 7. P_{out} versus V_{ramp} and Temperature

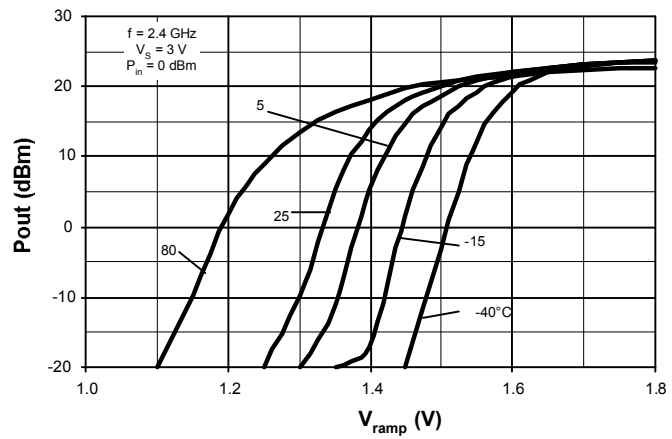

Figure 8. Output Power versus I_{Ramp} Current

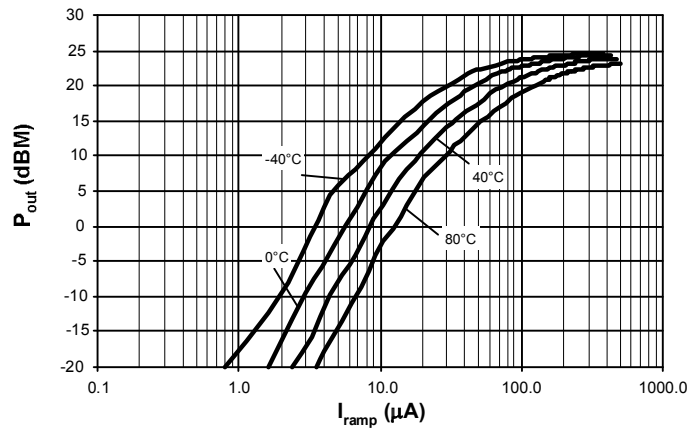
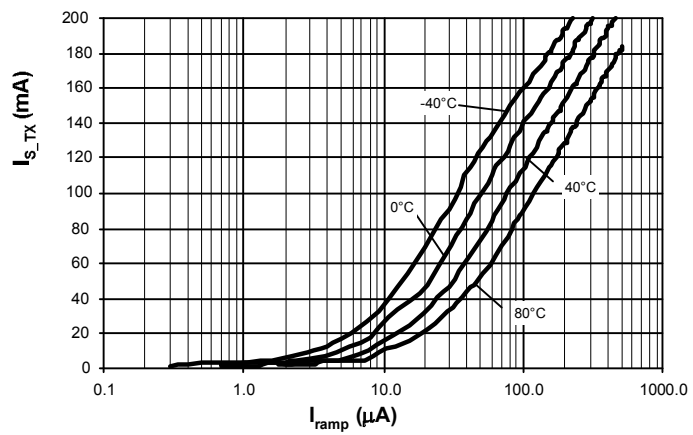

Figure 9. I_{S_TX} versus V_{Ramp} Current



Input/Output Circuits

Figure 10. Input Circuit PA_IN/V1_PA

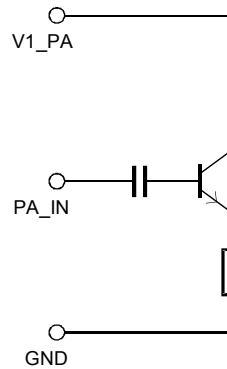

Figure 11. Input Circuit RAMP/V1_PA

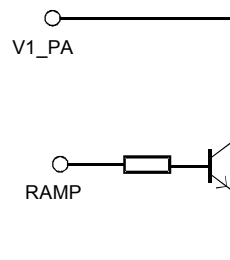

Figure 12. Input Circuit V2_PA

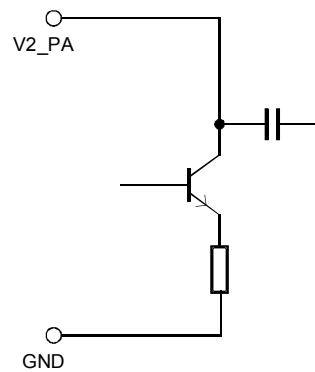

Figure 13. Input/Output Circuit V3_PA_OUT

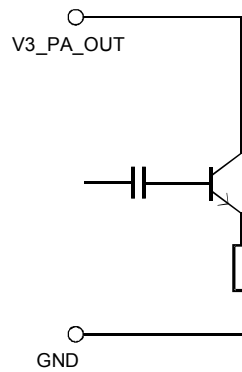
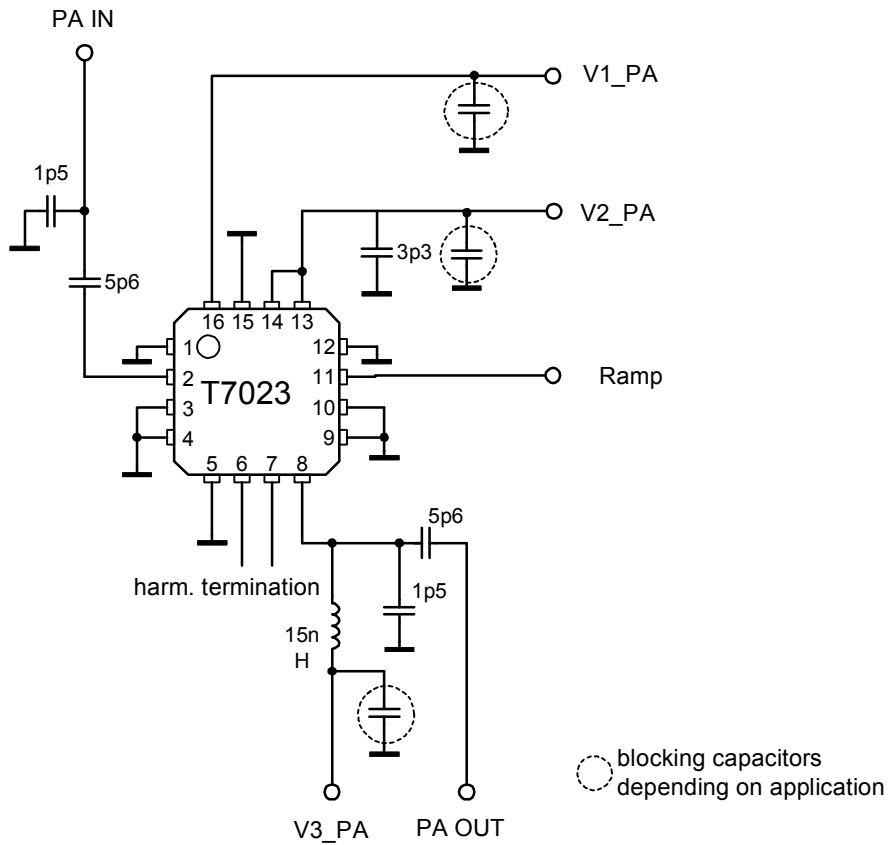

Figure 14. Application Board Schematic



Ordering Information

Extended Type Number	Package	Remarks
T7023-PES	HP-VFQFP-N16	Tube
T7023-PEQ	HP-VFQFP-N16	Taped and reeled

Package Information

Package: HP-VFQFP-N16

Exposed pad Var. A

(acc. JEDEC OUTLINE No. MO-220)

Dimensions in mm

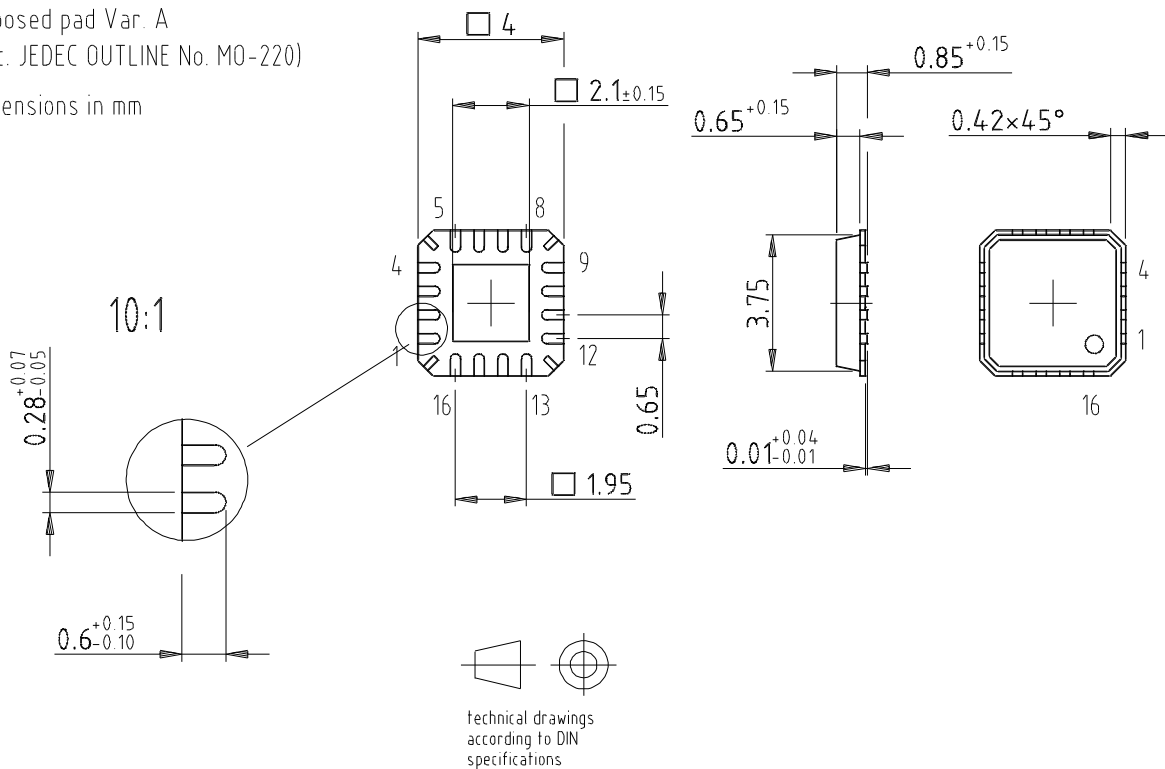



Atmel Headquarters

Corporate Headquarters
2325 Orchard Parkway
San Jose, CA 95131
TEL 1(408) 441-0311
FAX 1(408) 487-2600

Europe
Atmel Sarl
Route des Arsenaux 41
Case Postale 80
CH-1705 Fribourg
Switzerland
TEL (41) 26-426-5555
FAX (41) 26-426-5500

Asia
Room 1219
Chinachem Golden Plaza
77 Mody Road Tsimhatsui
East Kowloon
Hong Kong
TEL (852) 2721-9778
FAX (852) 2722-1369

Japan
9F, Tonetsu Shinkawa Bldg.
1-24-8 Shinkawa
Chuo-ku, Tokyo 104-0033
Japan
TEL (81) 3-3523-3551
FAX (81) 3-3523-7581

Atmel Operations

Memory
2325 Orchard Parkway
San Jose, CA 95131
TEL 1(408) 441-0311
FAX 1(408) 436-4314

Microcontrollers
2325 Orchard Parkway
San Jose, CA 95131
TEL 1(408) 441-0311
FAX 1(408) 436-4314

La Chantrerie
BP 70602
44306 Nantes Cedex 3, France
TEL (33) 2-40-18-18-18
FAX (33) 2-40-18-19-60

ASIC/ASSP/Smart Cards
Zone Industrielle
13106 Rousset Cedex, France
TEL (33) 4-42-53-60-00
FAX (33) 4-42-53-60-01

1150 East Cheyenne Mtn. Blvd.
Colorado Springs, CO 80906
TEL 1(719) 576-3300
FAX 1(719) 540-1759

Scottish Enterprise Technology Park
Maxwell Building
East Kilbride G75 0QR, Scotland
TEL (44) 1355-803-000
FAX (44) 1355-242-743

RF/Automotive
Theresienstrasse 2
Postfach 3535
74025 Heilbronn, Germany
TEL (49) 71-31-67-0
FAX (49) 71-31-67-2340

1150 East Cheyenne Mtn. Blvd.
Colorado Springs, CO 80906
TEL 1(719) 576-3300
FAX 1(719) 540-1759

**Biometrics/Imaging/Hi-Rel MPU/
High Speed Converters/RF Datacom**
Avenue de Rochepleine
BP 123
38521 Saint-Egreve Cedex, France
TEL (33) 4-76-58-30-00
FAX (33) 4-76-58-34-80

e-mail
literature@atmel.com

Web Site
<http://www.atmel.com>

© Atmel Corporation 2003.

Atmel Corporation makes no warranty for the use of its products, other than those expressly contained in the Company's standard warranty which is detailed in Atmel's Terms and Conditions located on the Company's web site. The Company assumes no responsibility for any errors which may appear in this document, reserves the right to change devices or specifications detailed herein at any time without notice, and does not make any commitment to update the information contained herein. No licenses to patents or other intellectual property of Atmel are granted by the Company in connection with the sale of Atmel products, expressly or by implication. Atmel's products are not authorized for use as critical components in life support devices or systems.

Atmel® is the registered trademark of Atmel.

The Bluetooth name and the Bluetooth trademarks are owned by Bluetooth SIG, Inc, and are used by Atmel Corporation under license.

Other terms and product names may be the trademarks of others.



Printed on recycled paper.