

SPECIFICATION

SPECIFICATIONS No.
Date: 2005.02.09
LAST SPECIFICATIONS No.
Date

Product Name **STK428-610-E**

Case Outline : 28pins -See attached outline drawing

Functions : 70W 2-channel Class D Audio Power Amplifier

Application : Audio Equipments

Features :

- Hybrid IC adopting Sanyo original technology IMST[®] -Insulated Metal Substrate Technology
- Pin-compatible series

Absolute Maximum Ratings at Ta=25°C (*1)

Parameter	Symbol	Conditions	Ratings	Unit
Maximum Power Supply Voltage	VD/VS max	Include spike voltage	+/-50	V
Driver Maximum Power Supply Voltage	VDR max		VS+15	
Analog Maximum Power Supply Voltage	VDD/VSS max		+/-7.5	V
Signal Input Voltage	IN1-,IN2+		+/-6	V
Thermal resistance	θ_{j-c}	Per power transistor	12.0	°C/W
Junction temperature	Tj max	Both the Tj max and Tc max conditions must be met.	150	°C
IC substrate operating temperature	Tc max		105	°C
Storage temperature	Tstg		-30 to +125	°C

Recommended Operating Conditions at Ta=25°C (*1)

Parameter	Symbol	Conditions	Ratings	Unit
Power Supply Voltage 1	VD/VS 1	RL=8Ω	+/-37 to +/-45	V
Power Supply Voltage 2	VD/VS 2	RL=4Ω	+/-28 to +/-34	V
Driver Supply Voltage	VDR		VS+9 to VS+11	
Analog Supply Voltage	VDD/VSS	Normal Operating	+/-4.5 to +/-5.5	V

Electrical Characteristics

at Ta=25°C, VDD/VSS=+5/-5V, VDR=VS+10V, RL=8Ω (noninductive load), Rg=600Ω, VG=24dB

Parameter	Symbol	Conditions					Ratings			Unit
		VD/VS [V] *2	f [Hz]	Po [W]	THD [%]		Min.	Typ.	Max.	
Output power*3, 4	Po 1	+41/-41	20 to 20k		0.8	RL=8Ω	70			W
	Po 2	+31/-31	1k		10	RL=4Ω		100		W
Power Stage Efficiency	η	+41/-41	1k	70		2ch drive	87			%
Frequency characteristics	fL, fH	+41/-41		1		+0/-3dB	20 to 20k			Hz
Input impedance	ri	+41/-41	1k	1				4.7		kΩ
Output noise voltage*3	VNO	+41/-41				Rg=0Ω A-weighted		1.0		mVrms
Quiescent current	IVDO	+41/-41				No load			50	mA
Neutral voltage	VN	+41/-41					-100	0	+100	mV

Specifications and information herein are subject to change without notice

[Note]

*1 The maximum rating cannot be exceeded at the moment, either. When the maximum rating is exceeded, H-IC may damage

*2 Use a constant-voltage supply for the power supply used during inspection.

*3 Use Audio Analyzer with Pre-LPF for removing switching element, and use 20kHz LPF.

High output power over the ratings may go to the protection mode.

*4 RC-Zobel is designed for music load. Long continuous high output at high frequency above 10kHz may go to the protection mode.

*5 Channel 1 is inverting and channel 2 is non-inverting.

*6 This product is based on ICE power[®] technologies developed by Bang & Olufsen ICE power.

RoHS DIRECTIVE PASS

(5-XXXX)

050209

SANYO Electric Co.,Ltd. Semiconductor Company

No.1

Interface and Protection

TC=25°C, VD/VS=+41/-41V, VDD/VSS=+5/-5V, VDR=VS+10V, RL=8 Ω (Non-inductive Load), f=1kHz, Rg=600 Ω, VG=24dB

Item	Symbol	I/O	Conditions					Ratings			Unit
			VD/VS (V)	f (Hz)	Po (W)	THD (%)		min	typ	max	
Over voltage detect VDCK	VD ck	I							1.82	2.22	V
Over voltage detect VSCK	VS ck	I						-2.22	-1.82		V
Enable Input High	ENA-I-H	I							2.7	3.5	V
Enable Input Low	ENA-I-L	I						1.4	2.0		V
Enable Output High	ENA-O-H	O					10kΩ pull-up		VDD		V
Enable Output Low	ENA-O-L	O					0.5mA			2.0	V
Over Current Protection level	OCP	O		1k		10		11			A
Over Current Monitor Output High	OCM-H	O					10kΩ pull-up		VDD		V
Over Current Monitor Output Low	OCM-L	O					0.5mA			2.0	V
Thermal monitor High → Low	OCM-L *1,2 (THM-L)	O						105	130		°C
Discharge Output High	DCG-H	O							1.0		V
Discharge Output Low	DCG-L	O								-4.5	V

*1 Thermal detection temperature indicates the value at unusual operation, therefore, does not indicate the guaranteed value at usual operation

*2 OCM(Over Current Monitor) is shared THM terminal by common collectors.

Equivalent Block Diagram

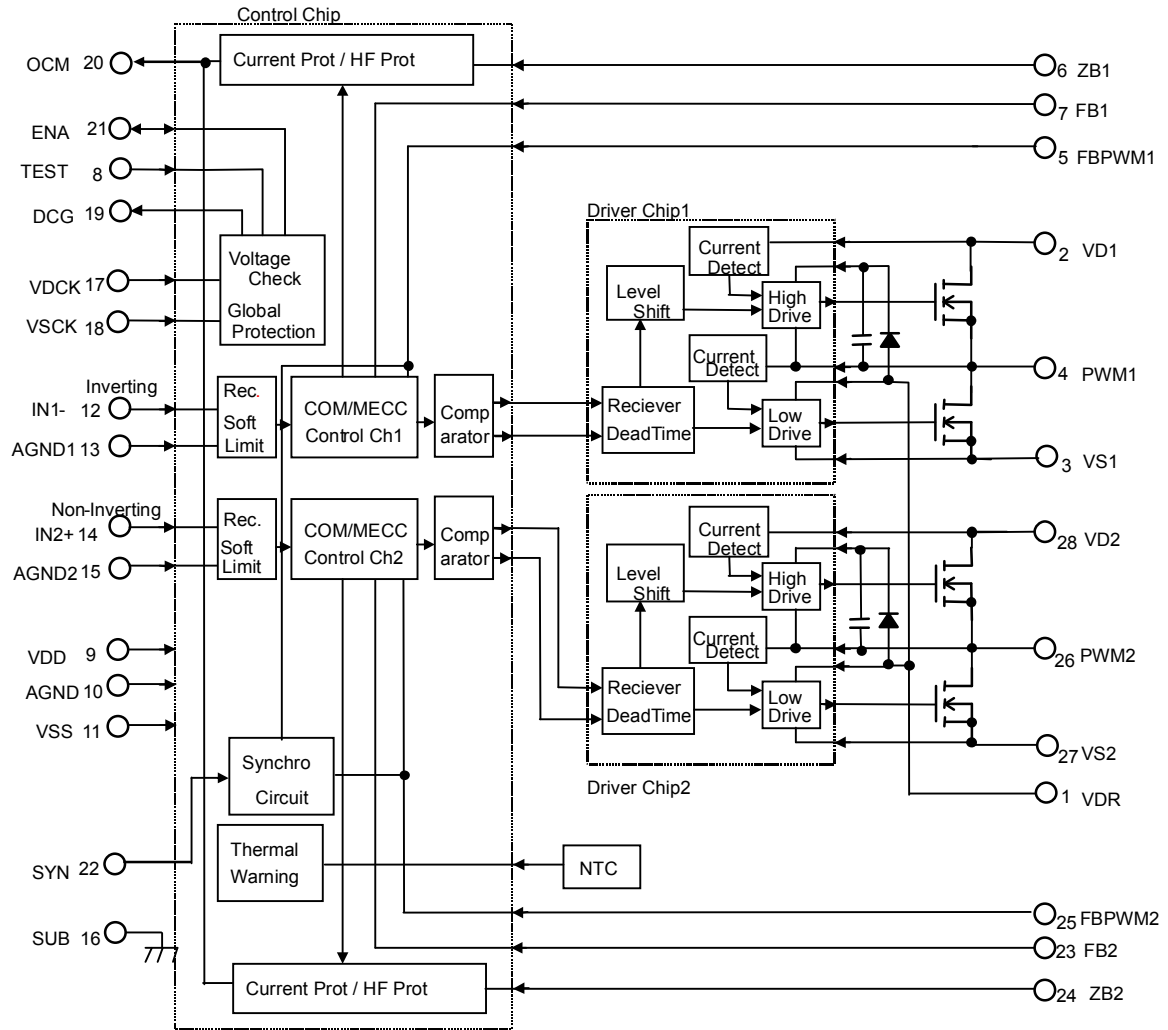

Test Circuit

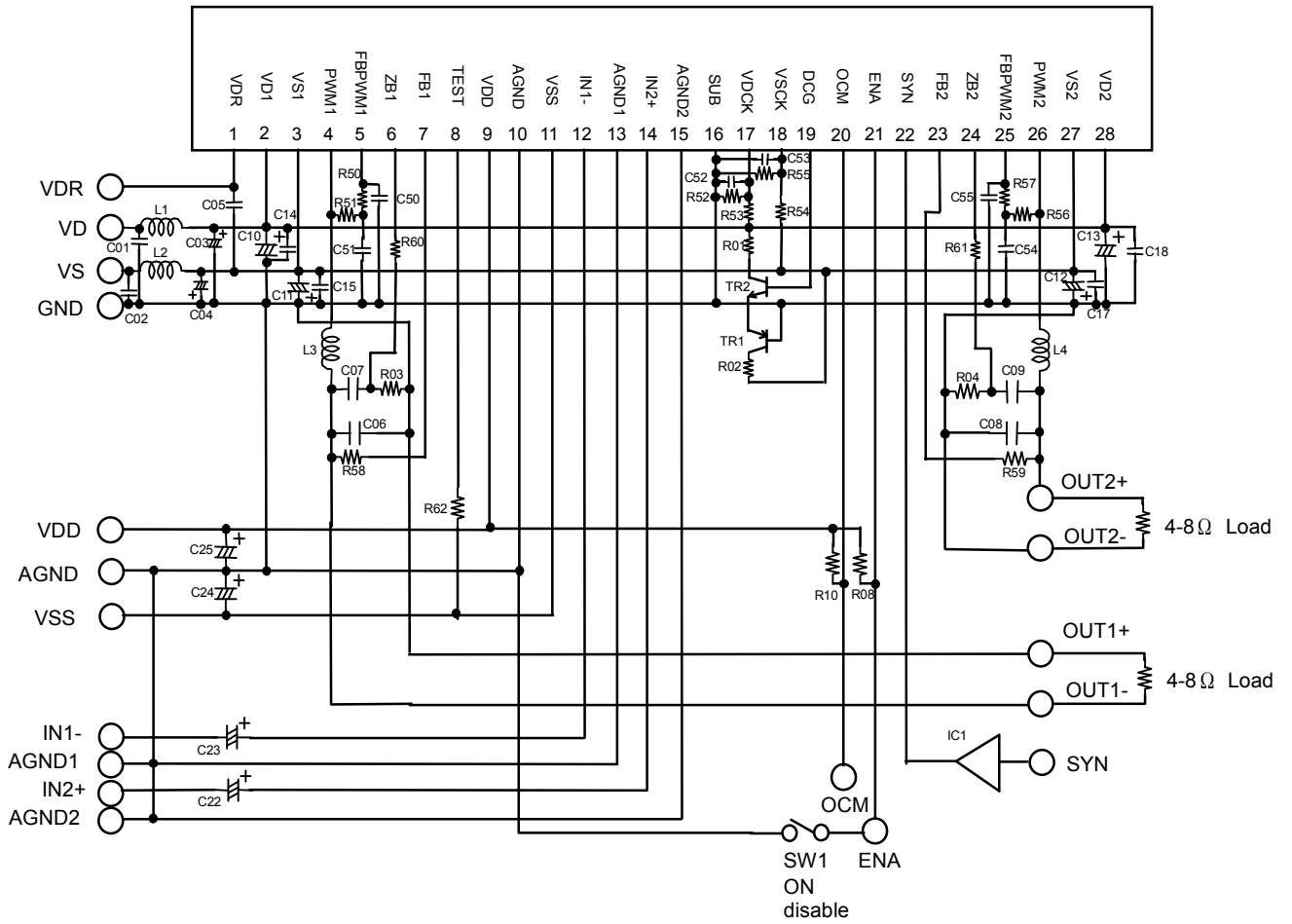

Notice1: Channel 1 is inverting and Channel 2 is non inverting.

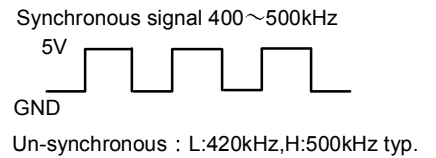
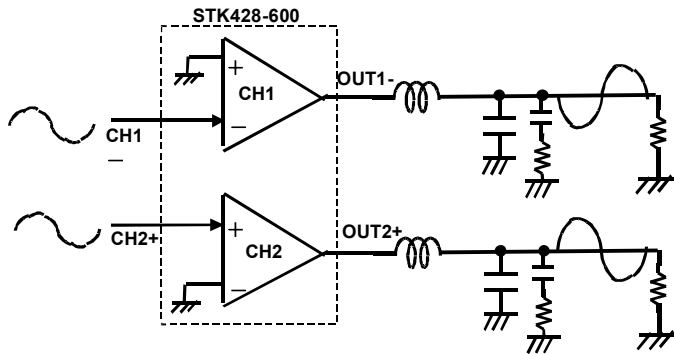

Sample Application Circuit

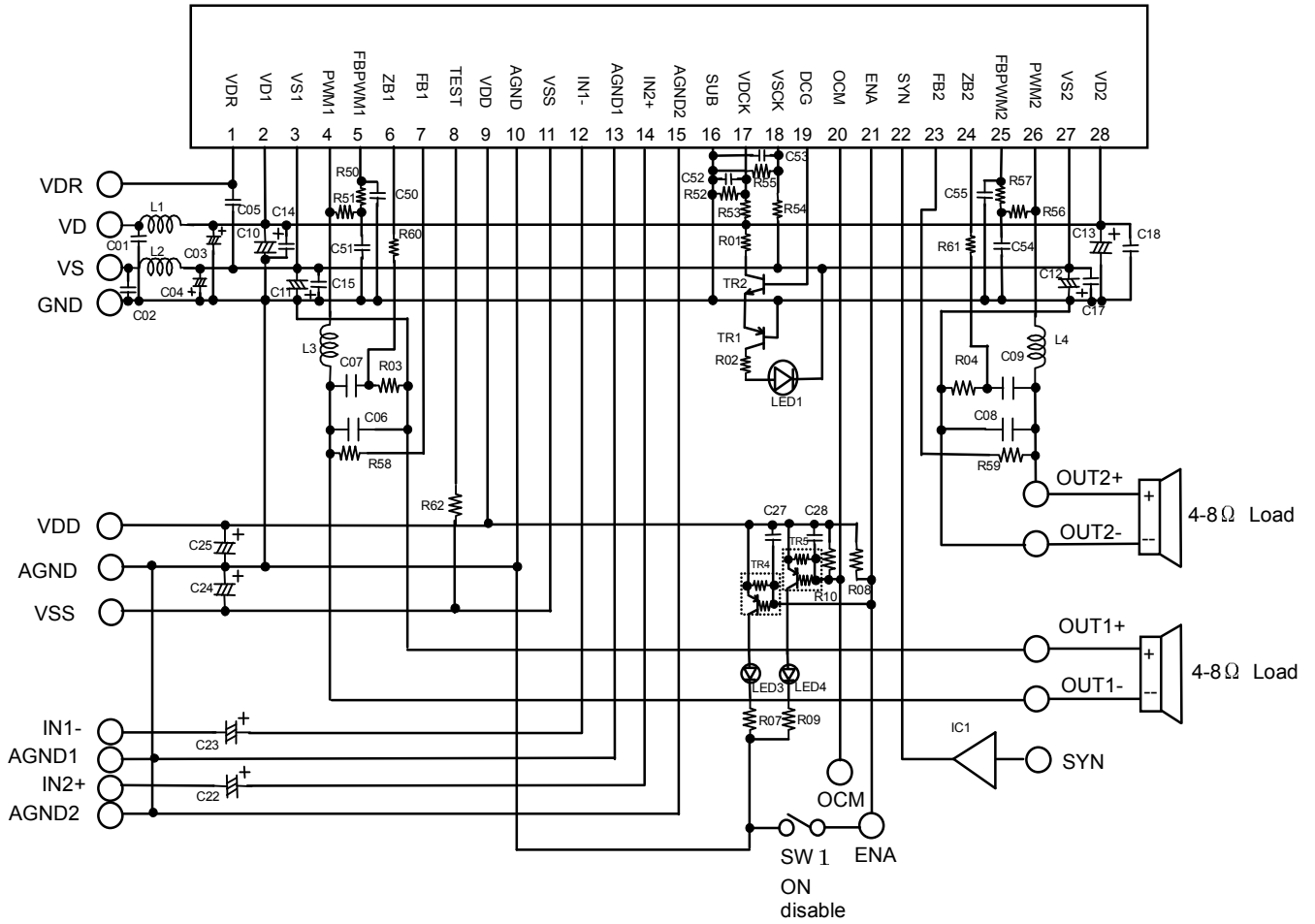

Notice1: Channel 1 is inverting and Channel 2 is non inverting.

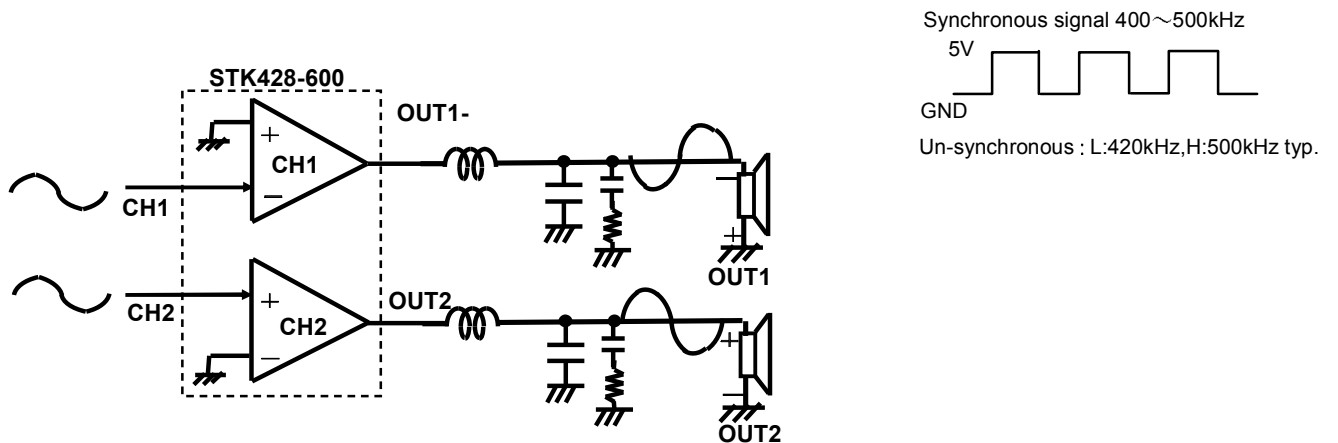

Application Circuit Parts List

Rocation	Name	Ratings
C01, C02, C05	Film Capacitor	0.1uF / 100V
C03, C04, C10, C11, C12, C13	Electrolytic condenser	1000uF / 63V
C06, C08	Film Capacitor	0.47uF / 100V
C07, C09	Film Capacitor	0.39uF / 100V
C14, C15, C17, C18	Ceramic Capacitor	0.1uF / 100V
C22, C23	Electrolytic condenser	22uF / 50V
C24, C25	Electrolytic condenser	47uF / 63V
C27, C28	Ceramic Capacitor	220pF / 100V
C50, C55	open	open
C51, C54	Ceramic Capacitor	330pF / 100V
C52, C53	Ceramic Capacitor	2200pF / 100V
R01, R02	Resistor	1.2k Ω / 2W
R03, R04	Resistor	4.7 Ω / 2 W
R07, R09	Resistor	10k Ω / 1/4W
R08, R10, R62	Resistor	10k Ω / 1/4W
R50, R57	Resistor	4.7k Ω / 1/4W
R51, R56	Resistor	12k Ω / 1/4W
R52, 55	Resistor	3.3k Ω / 1/6W
R53, R54	Resistor	62k Ω / 1/4W
R58, R59	Resistor	18k Ω / 1/4W
R60, R61	Resistor	15k Ω / 1/4W
L1, L2	Inductor	2.1uH
L3, L4	Troidal Coil	20uH
LED1,3,4	LED	5V
IC1	Buffer	74AC244
TR1	Transistor	2SA984
TR2	Transistor	2SC2274
TR3, TR4, TR5	Transistor	2SA1345
SW1	Switch	B-12AP
J1	Connector	2mm / 28pin
J3	Connector	5.08mm / 4pin

Pin configuration

PIN	SYMBOL	DESCRIPTION
1	VDR	Positive supply for driver chip with respect to VS1,2; (VS1,2+10V).
2	VD1	Positive supply for power stage of channel 1.
3	VS1	Negative supply for power stage of channel 1.
4	PWM1	PWM output of channel 1.
5	FBPWM1	Feedback for inner loop of channel 1.
6	ZB1	For estimating the power dissipation in the zobel resistor, this input is sensing the zobel voltage via a resistive network of channel 1.
7	FB1	Feedback for global loop of channel 1.
8	TEST	Test terminal connect to VSS.
9	VDD	Positive power supply for control chip (+5V).
10	AGND	Analog ground for control chip power supply.
11	VSS	Negative power supply for control chip (-5V).
12	IN1-	High impedance audio input for channel 1. This input is inverting.
13	AGND1	Input reference for channel 1. This is true non-inverting low impedance (2kohm) input for avoiding ground loop noise.
14	IN2+	High impedance audio input for channel 2. This input is non-inverting.
15	AGND2	Input reference for channel 2. This is true inverting low impedance (1kohm) input for avoiding ground loop noise.
16	SUB	Substrate of IMST.
17	VDCK	This high impedance input for monitoring positive power stage. This monitoring controls the soft clipping circuit and the over voltage shutdown.
18	VSCK	This high impedance input for monitoring negative power stage. This monitoring controls the soft clipping circuit and the over voltage shutdown.
19	DCG	This high impedance output generates a current in case of over voltage condition on the power stage voltage (VD/VS). This current is designed to turn-on a set of discharge transistors.
20	OCM	Error signal of open collector output "L" for three conditions. 1. Over current limitation. 2. For monitoring the state of control and average voltage across the zobel resistor in case of of-limit conditions. 3. Over temperature warning. By connecting to the ENA pin, thermal shutdown is set.
21	ENA	Bi-direction input/output. The input "H" enables to start switching and the input "L" disables. Input is including hysteresis for glitch free enable of the system. When the protection circuit detects the over voltage condition, the open collector output turns on.
22	SYN	The switching frequency can be synchronized with frequency of this pin signal to avoid the influence for AM radio tuner. Normal condition is "L".
23	FB2	Feedback for global loop of channel 2
24	ZB2	For estimating the power dissipation in the zobel resistor, this input is sensing the zobel voltage via a resistive network of channel 2.
25	FBPWM2	Feedback for inner loop of channel 2
26	PWM2	PWM output of channel 2
27	VS2	Negative supply for power stage of channel 2
28	VD2	Positive supply for power stage of channel 2

