

SATISFIES REQUIREMENTS OF EIA STANDARD RS-232-C

CIRCUIT TYPE SN75150
BULLETIN NO. DL-S-7111428, JANUARY 1971

- Withstands Sustained Output Short-Circuit to any Low-Impedance Voltage between -25 V and 25 V
- $2\ \mu\text{s}$ Max Transition Time through the $+3\text{ V}$ to -3 V Transition Region under Full 2500-pF Load
- Inputs Compatible with Most TTL and DTL Families
- Common Strobe Input
- Inverting Output
- Slew Rate can be Controlled with an External Capacitor at the Output
- Standard Supply Voltages . . . $\pm 12\text{ V}$

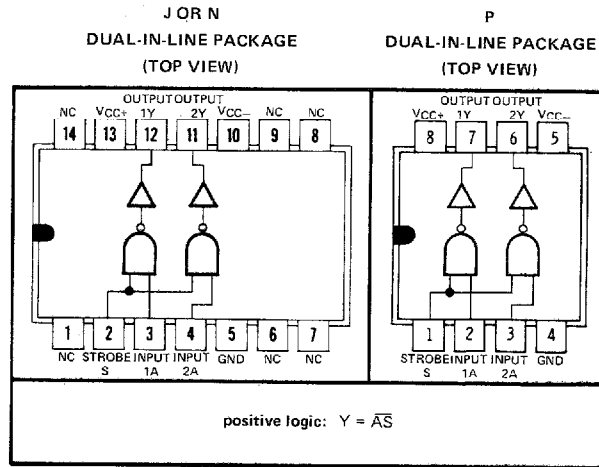

3

description

The SN75150 is a monolithic dual line driver designed to satisfy the requirements of the standard interface between data terminal equipment and data communication equipment as defined by EIA Standard RS-232-C. A rate of 20,000 bits per second can be transmitted with a full 2500-pF load. Other applications are in data-transmission systems using relatively short single lines, in level translators, and for driving MOS devices. The logic input is compatible with most TTL and DTL families. Operation is from $+12\text{-volt}$ and -12-volt power supplies. The SN75150 is characterized for operation from 0°C to 70°C .

schematic (each line driver)

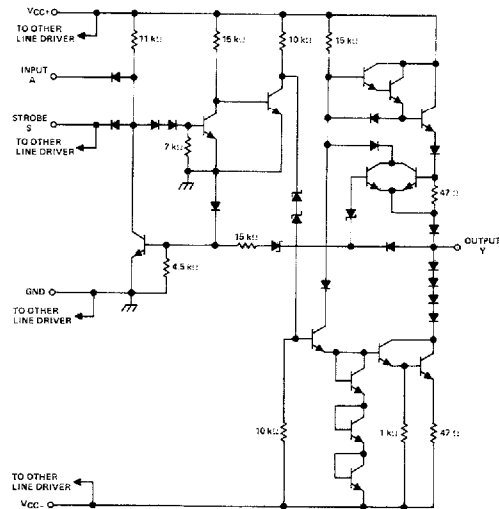

Component values shown are nominal.

absolute maximum ratings over operating free-air temperature range (unless otherwise noted)

Supply voltage V_{CC+} (see Note 1)	15 V
Supply voltage V_{CC-} (see Note 1)	-15 V
Input voltage (see Note 1)	15 V
Applied output voltage (see Note 1)	$\pm 25\text{ V}$
Operating free-air temperature range	0°C to 70°C
Storage temperature range	-65°C to 150°C

NOTE 1: Voltage values are with respect to network ground terminal.

CIRCUIT TYPE SN75150

DUAL LINE DRIVER

recommended operating conditions

	MIN	NOM	MAX	UNIT
Supply voltage V_{CC+}	10.8	12	13.2	V
Supply voltage V_{CC-}	-10.8	-12	-13.2	V
Input voltage, V_I	0		5.5	V
Applied output voltage, V_O			±15	V
Operating free-air temperature, T_A	0	25	70	°C

electrical characteristics over recommended operating free-air temperature range (unless otherwise noted)

PARAMETER	TEST FIGURE	TEST CONDITIONS	MIN	TYP [†]	MAX	UNIT
V_{IH} High-level input voltage	1		2			V
V_{IL} Low-level input voltage	2				0.8	V
V_{OH} High-level output voltage	2	$V_{CC+} = 10.8$ V, $V_{CC-} = -13.2$ V, $V_{IL} = 0.8$ V, $R_L = 3$ k Ω to 7 k Ω	5	8		V
V_{OL} Low-level output voltage	1	$V_{CC+} = 10.8$ V, $V_{CC-} = -10.8$ V, $V_{IH} = 2$ V, $R_L = 3$ k Ω to 7 k Ω	-8	-5		V
I_{IH} High-level input current	3	$V_{CC+} = 13.2$ V, $V_{CC-} = -13.2$ V, $V_I = 2.4$ V	Data input	1	10	μ A
			Strobe input	2	20	
I_{IL} Low-level input current	3	$V_{CC+} = 13.2$ V, $V_{CC-} = -13.2$ V, $V_I = 0.4$ V	Data input	-1	-1.6	mA
			Strobe input	-2	-3.2	
I_{OS} Short-circuit output current	4	$V_{CC+} = 13.2$ V, $V_{CC-} = -13.2$ V	$V_O = 25$ V	2		mA
			$V_O = -25$ V		-3	
			$V_O = 0$ V, $V_I = 3$ V		15	
			$V_O = 0$ V, $V_I = 0$ V		-15	
I_{CCH+} Supply current from V_{CC+} , high-level output	5	$V_{CC+} = 13.2$ V, $V_I = 0$ V, $T_A = 25^\circ$ C	$V_{CC-} = -13.2$ V, $R_L = 3$ k Ω ,	10	22	mA
				-1	-10	
I_{CCL+} Supply current from V_{CC+} , low-level output	5	$V_{CC+} = 13.2$ V, $V_I = 3$ V, $T_A = 25^\circ$ C	$V_{CC-} = -13.2$ V, $R_L = 3$ k Ω ,	8	17	mA
I_{CCL-} Supply current from V_{CC-} , low-level output					-9	

NOTE 2: The algebraic convention where the most positive (least-negative) limit is designated as maximum is used in this data sheet for logic levels only, e.g., when -5 V is the maximum, the typical value is a more-negative voltage.

[†] All typical values are at $V_{CC+} = 12$ V, $V_{CC-} = -12$ V, $T_A = 25^\circ$ C.

switching characteristics, $V_{CC+} = 12$ V, $V_{CC-} = -12$ V, $T_A = 25^\circ$ C

PARAMETER	TEST FIGURE	TEST CONDITIONS	MIN	TYP	MAX	UNIT
t_{TLH} Transition time, low-to-high-level output	6	$C_L = 2500$ pF, $R_L = 3$ k Ω to 7 k Ω	0.2	1.4	2	μ s
t_{THL} Transition time, high-to-low-level output			0.2	1.5	2	
t_{TLH} Transition time, low-to-high-level output	6	$C_L = 15$ pF, $R_L = 7$ k Ω		40		ns
t_{THL} Transition time, high-to-low-level output				20		
t_{PLH} Propagation delay time, low-to-high-level output	6	$C_L = 15$ pF, $R_L = 7$ k Ω		60		ns
t_{PHL} Propagation delay time, high-to-low-level output				45		

CIRCUIT TYPE SN75150 DUAL LINE DRIVER

PARAMETER MEASUREMENT INFORMATION

d-c test circuits[‡]

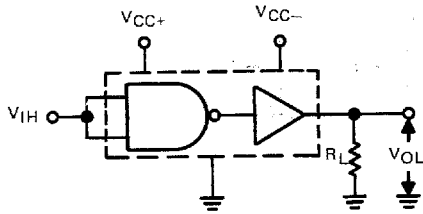
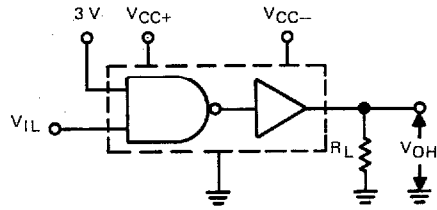

FIGURE 1— V_{IH} , V_{OL}



Each input is tested separately.

FIGURE 2— V_{IL} , V_{OH}

3

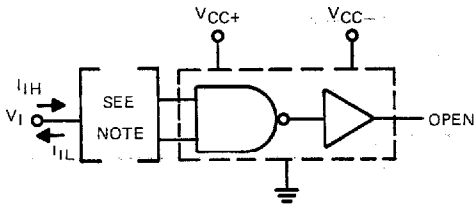

NOTE: When testing I_{IH} , the other input is at 3 V; when testing I_{IL} , the other input is open.

FIGURE 3— I_{IH} , I_{IL}

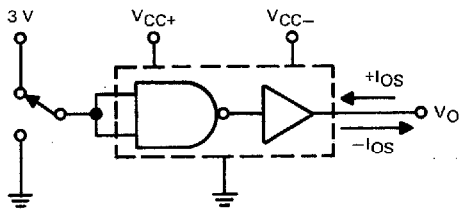

I_{OS} is tested for both input conditions at each of the specified output conditions.

FIGURE 4— I_{OS}

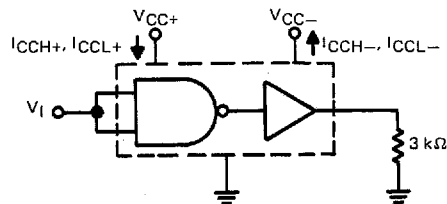

FIGURE 5— I_{CCH+} , I_{CCH-} , I_{CCL+} , I_{CCL-}

[‡]Arrows indicate actual direction of current flow. Current into a terminal is a positive value.

CIRCUIT TYPE SN75150

DUAL LINE DRIVER

PARAMETER MEASUREMENT INFORMATION

switching characteristics

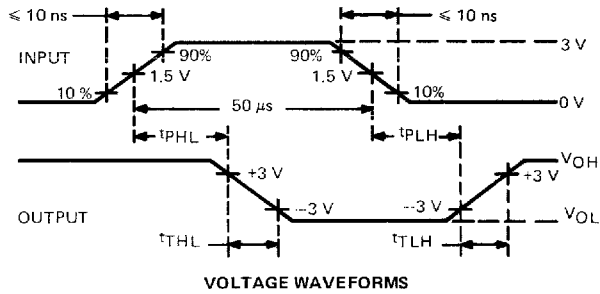
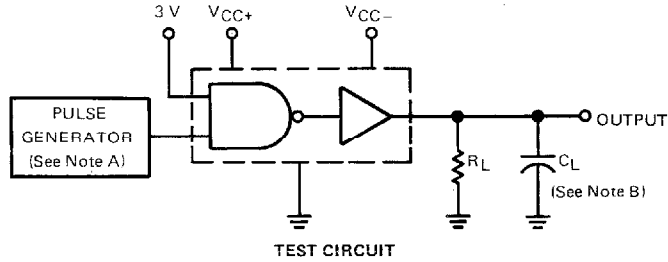

NOTES: A. The pulse generator has the following characteristics: duty cycle $\leq 50\%$, $Z_{out} \approx 50 \Omega$.
 B. C_L includes probe and jig capacitance.

FIGURE 6—SWITCHING CHARACTERISTICS

TYPICAL CHARACTERISTICS

