

SN54LS373, SN54LS374, SN54S373, SN54S374, SN74LS373, SN74LS374, SN74S373, SN74S374

OCTAL D-TYPE TRANSPARENT LATCHES AND EDGE-TRIGGERED FLIP-FLOPS

SDLS165 – OCTOBER 1975 – REVISED MARCH 1988

- Choice of 8 Latches or 8 D-Type Flip-Flops In a Single Package
- 3-State Bus-Driving Outputs
- Full Parallel-Access for Loading
- Buffered Control Inputs
- Clock/Enable Input Has Hysteresis to Improve Noise Rejection ('S373 and 'S374)
- P-N-P Inputs Reduce D-C Loading on Data Lines ('S373 and 'S374)

SN54LS373, SN54LS374, SN54S373,
SN54S374 . . . J OR W PACKAGE
SN74LS373, SN74LS374, SN74S373,
SN74S374 . . . DW OR N PACKAGE

(TOP VIEW)

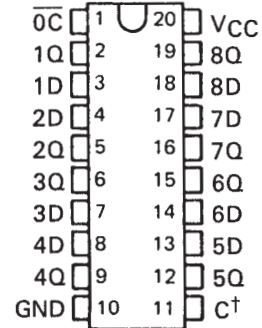

SN54LS373, SN54LS374, SN54S373,
SN54S374 . . . FK PACKAGE

(TOP VIEW)

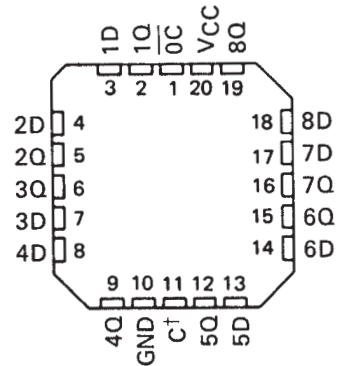

'LS373, 'S373
FUNCTION TABLE

OUTPUT ENABLE	ENABLE LATCH	D	OUTPUT
L	H	H	H
L	H	L	L
L	L	X	Q ₀
H	X	X	Z

'LS374, 'S374
FUNCTION TABLE

OUTPUT ENABLE	CLOCK	D	OUTPUT
L	↑	H	H
L	↑	L	L
L	L	X	Q ₀
H	X	X	Z

description

These 8-bit registers feature three-state outputs designed specifically for driving highly-capacitive or relatively low-impedance loads. The high-impedance third state and increased high-logic-level drive provide these registers with the capability of being connected directly to and driving the bus lines in a bus-organized system without need for interface or pull-up components. They are particularly attractive for implementing buffer registers, I/O ports, bidirectional bus drivers, and working registers.

The eight latches of the 'LS373 and 'S373 are transparent D-type latches meaning that while the enable (C) is high the Q outputs will follow the data (D) inputs. When the enable is taken low the output will be latched at the level of the data that was set up.

†C for 'LS373 and 'S373; CLK for 'LS374 and 'S374.

PRODUCTION DATA information is current as of publication date. Products conform to specifications per the terms of Texas Instruments standard warranty. Production processing does not necessarily include testing of all parameters.



SN54LS373, SN54LS374, SN54S373, SN54S374, SN74LS373, SN74LS374, SN74S373, SN74S374 OCTAL D-TYPE TRANSPARENT LATCHES AND EDGE-TRIGGERED FLIP-FLOPS

SDLS165 – OCTOBER 1975 – REVISED MARCH 1988

description (continued)

The eight flip-flops of the 'LS374 and 'S374 are edge-triggered D-type flip-flops. On the positive transition of the clock, the Q outputs will be set to the logic states that were setup at the D inputs.

Schmitt-trigger buffered inputs at the enable/clock lines of the 'S373 and 'S374 devices, simplify system design as ac and dc noise rejection is improved by typically 400 mV due to the input hysteresis. A buffered output control input can be used to place the eight outputs in either a normal logic state (high or low logic levels) or a high-impedance state. In the high-impedance state the outputs neither load nor drive the bus lines significantly.

The output control does not affect the internal operation of the latches or flip-flops. That is, the old data can be retained or new data can be entered even while the outputs are off.

logic diagrams (positive logic)

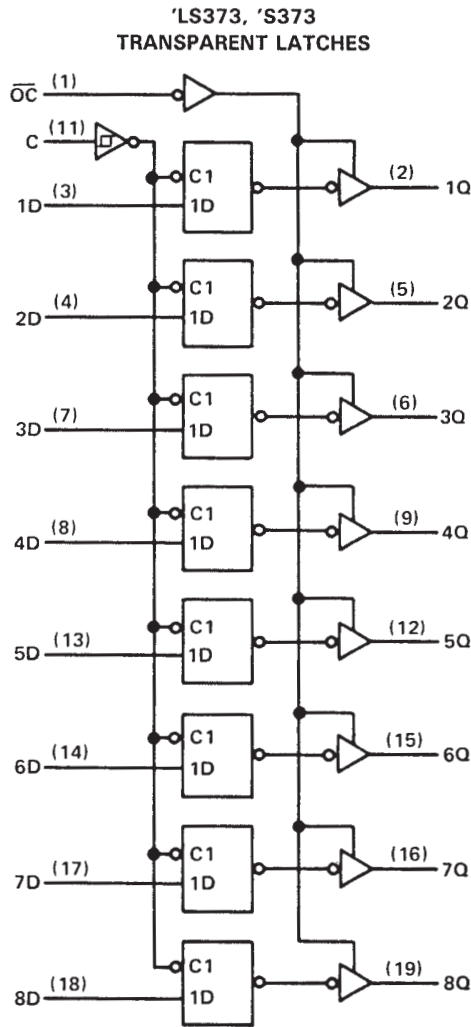

□ for 'S373 only

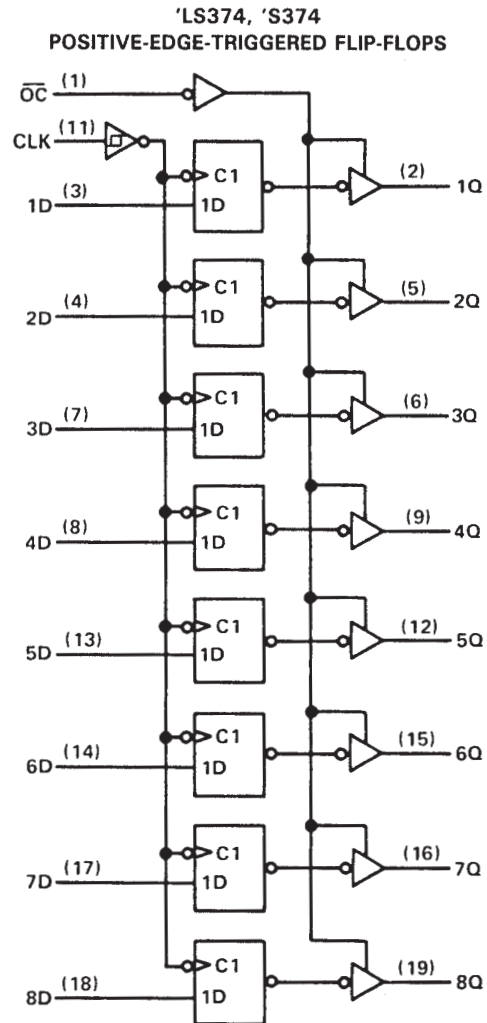

□ for 'S374 only

Pin numbers shown are for DW, J, N, and W packages.

SN54LS373, SN54LS374, SN54S373, SN54S374,
SN74LS373, SN74LS374, SN74S373, SN74S374
OCTAL D-TYPE TRANSPARENT LATCHES AND EDGE-TRIGGERED FLIP-FLOPS

SDLS165 - OCTOBER 1975 - REVISED MARCH 1988

schematic of inputs and outputs

'LS373

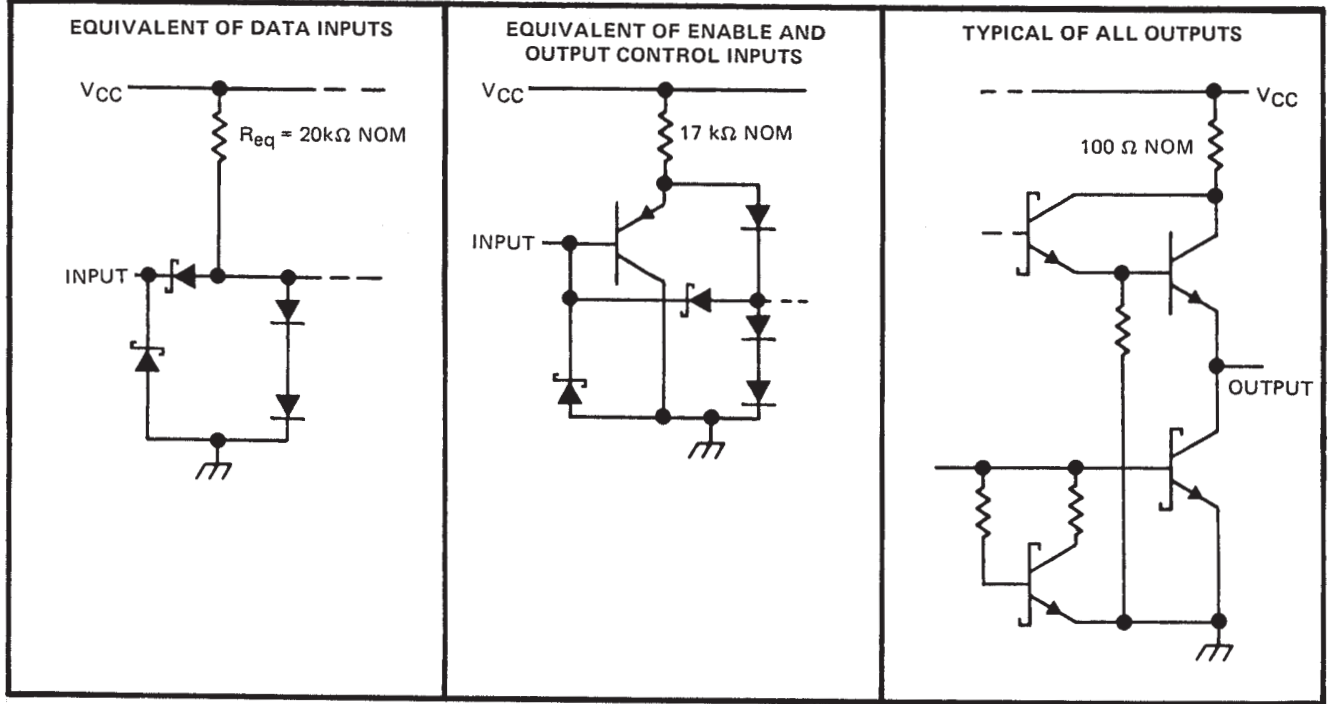

'LS374

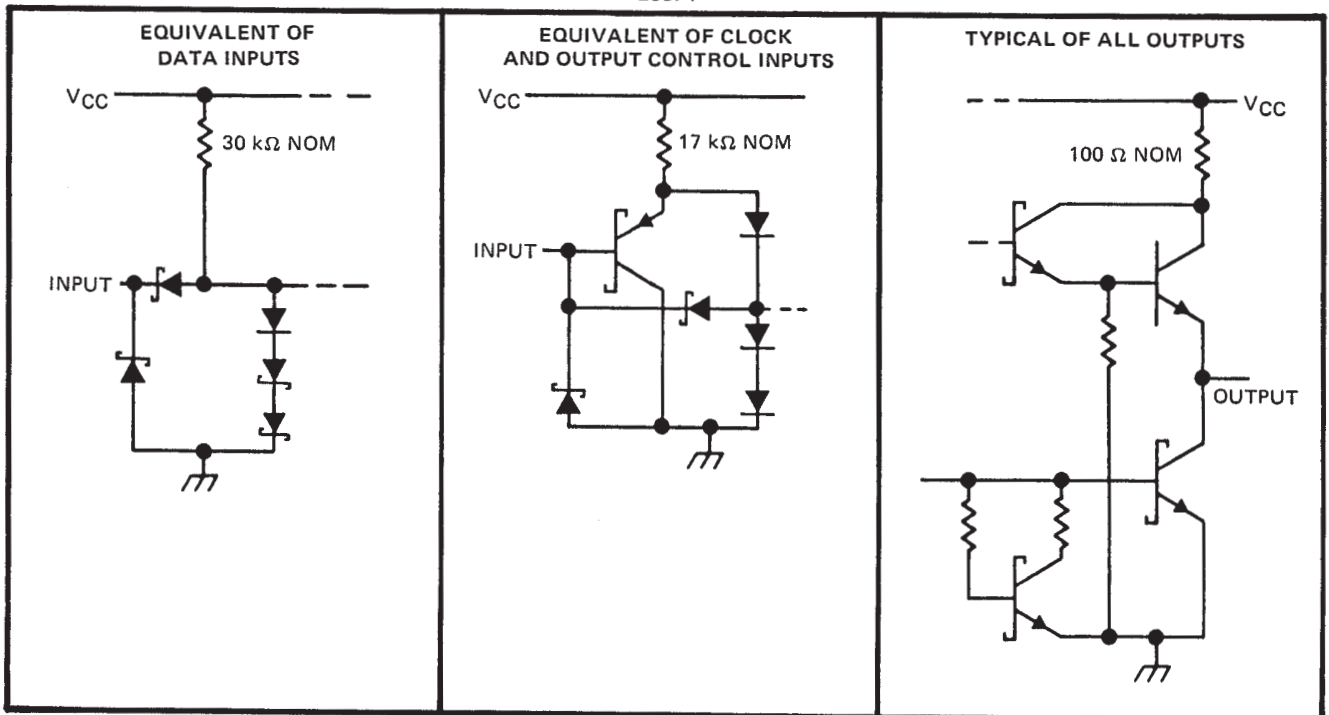

**SN54LS373, SN54LS374, SN54S373, SN54S374,
SN74LS373, SN74LS374, SN74S373, SN74S374
OCTAL D-TYPE TRANSPARENT LATCHES AND EDGE-TRIGGERED FLIP-FLOPS**

SDLS165 – OCTOBER 1975 – REVISED MARCH 1988

absolute maximum ratings over operating free-air temperature range (unless otherwise noted)

Supply voltage, V_{CC} (see Note 1)	7 V
Input voltage	7 V
Off-state output voltage	5.5 V
Operating free-air temperature range: SN54LS'	-55°C to 125°C
SN74LS'	0°C to 70°C
Storage temperature range	-65°C to 150°C

NOTE 1: Voltage values are with respect to network ground terminal.

recommended operating conditions

		SN54LS'			SN74LS'			UNIT
		MIN	NOM	MAX	MIN	NOM	MAX	
V_{CC}	Supply voltage	4.5	5	5.5	4.75	5	5.25	V
V_{OH}	High-level output voltage			5.5			5.5	V
I_{OH}	High-level output current			-1			-2.6	mA
I_{OL}	Low-level output current			12			24	mA
t_w	Pulse duration	CLK high		15			15	ns
		CLK low		15			15	
t_{su}	Data setup time	'LS373		5 ↓			5 ↓	ns
		'LS374		20 ↑			20 ↑	
t_h	Data hold time	'LS373		20 ↓			20 ↓	ns
		'LS374 †		5 ↑			0 ↑	
T_A	Operating free-air temperature	-55		125	0		70	°C

† The t_h specification applies only for data frequency below 10 MHz. Designs above 10 MHz should use a minimum of 5 ns. (Commercial only)

electrical characteristics over recommended operating free-air temperature range (unless otherwise noted)

PARAMETER	TEST CONDITIONS†	SN54LS'			SN74LS'			UNIT		
		MIN	TYP‡	MAX	MIN	TYP‡	MAX			
V_{IH}	High-level input voltage	2			2			V		
V_{IL}	Low-level input voltage			0.7			0.8	V		
V_{IK}	Input clamp voltage	$V_{CC} = \text{MIN}, I_I = -18 \text{ mA}$					-1.5	V		
V_{OH}	High-level output voltage	$V_{CC} = \text{MIN}, V_{IH} = 2 \text{ V}, V_{IL} = V_{IL\text{max}}, I_{OH} = \text{MAX}$			2.4	3.4	2.4	3.1	V	
V_{OL}	Low-level output voltage	$V_{CC} = \text{MIN}, V_{IH} = 2 \text{ V}, V_{IL} = V_{IL\text{max}}$			$I_{OL} = 12 \text{ mA}$	0.25	0.4	0.25	0.4	V
					$I_{OL} = 24 \text{ mA}$			0.35	0.5	
I_{OZH}	Off-state output current, high-level voltage applied	$V_{CC} = \text{MAX}, V_{IH} = 2 \text{ V}, V_O = 2.7 \text{ V}$					20	20	μA	
I_{OZL}	Off-state output current, low-level voltage applied	$V_{CC} = \text{MAX}, V_{IH} = 2 \text{ V}, V_O = 0.4 \text{ V}$					-20	-20	μA	
I_I	Input current at maximum input voltage	$V_{CC} = \text{MAX}, V_I = 7 \text{ V}$					0.1	0.1	mA	
I_{IH}	High-level input current	$V_{CC} = \text{MAX}, V_I = 2.7 \text{ V}$					20	20	μA	
I_{IL}	Low-level input current	$V_{CC} = \text{MAX}, V_I = 0.4 \text{ V}$					-0.4	-0.4	mA	
I_{OS}	Short-circuit output current§	$V_{CC} = \text{MAX}$			-30	-130	-30	-130	mA	
I_{CC}	Supply current	$V_{CC} = \text{MAX},$					24	40	mA	
		Output control at 4.5 V			'LS373		24	40		
				'LS374		27	40			

† For conditions shown as MIN or MAX, use the appropriate value specified under recommended operating conditions.

‡ All typical values are at $V_{CC} = 5 \text{ V}, T_A = 25^\circ\text{C}$.

§ Not more than one output should be shorted at a time and duration of the short circuit should not exceed one second.



SN54LS373, SN54LS374, SN54S373, SN54S374,
SN74LS373, SN74LS374, SN74S373, SN74S374
OCTAL D-TYPE TRANSPARENT LATCHES AND EDGE-TRIGGERED FLIP-FLOPS

SDLS165 – OCTOBER 1975 – REVISED MARCH 1988

switching characteristics, $V_{CC} = 5\text{ V}$, $T_A = 25^\circ\text{C}$

PARAMETER	FROM (INPUT)	TO (OUTPUT)	TEST CONDITIONS	'LS373			'LS374			UNIT
				MIN	TYP	MAX	MIN	TYP	MAX	
f_{max}			$C_L = 45\text{ pF}$, $R_L = 667\ \Omega$ See Notes 2 and 3				35	50		MHz
t_{PLH}	Data	Any Q		12	18					ns
t_{PHL}				12	18					
t_{PLH}	Clock or enable	Any Q		20	30		15	28		ns
t_{PHL}				18	30		19	28		
t_{PZH}	Output	Any Q		15	28		20	26		ns
t_{PZL}	Control		25	36		21	28			
t_{PHZ}	Output Control	Any Q	$C_L = 5\text{ pF}$, $R_L = 667\ \Omega$ See Note 3	15	25		15	28		ns
t_{PLZ}	Output Control			12	20		12	20		ns

NOTES: 2. Maximum clock frequency is tested with all outputs loaded.
3. Load circuits and voltage waveforms are shown in Section 1.

f_{max} = maximum clock frequency
 t_{PLH} = propagation delay time, low-to-high-level output
 t_{PHL} = propagation delay time, high-to-low-level output
 t_{PZH} = output enable time to high level
 t_{PZL} = output enable time to low level
 t_{PHZ} = output disable time from high level
 t_{PLZ} = output disable time from low level



**SN54LS373, SN54LS374, SN54S373, SN54S374,
SN74LS373, SN74LS374, SN74S373, SN74S374**
OCTAL D-TYPE TRANSPARENT LATCHES AND EDGE-TRIGGERED FLIP-FLOPS

SDLS165 – OCTOBER 1975 – REVISED MARCH 1988

schematic of inputs and outputs

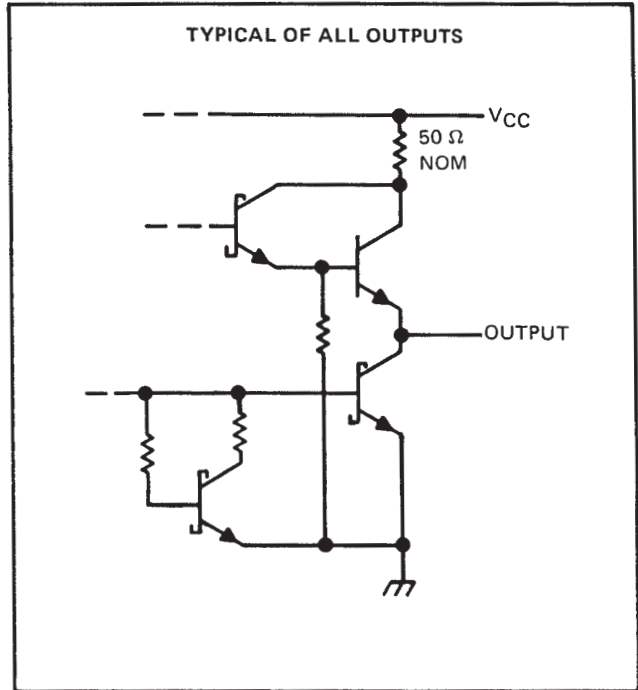
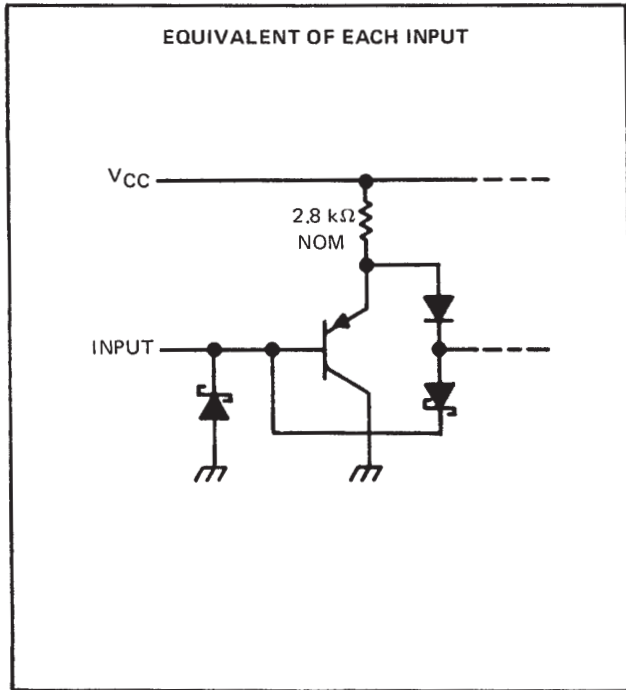

absolute maximum ratings over operating free-air temperature range (unless otherwise noted)

Supply voltage, V_{CC} (see Note 1)	7 V
Input voltage	5.5 V
Off-state output voltage	5.5 V
Operating free-air temperature range: SN54S'	-55°C to 125°C
SN74S'	0°C to 70°C
Storage temperature range	-65°C to 150°C

NOTE 1: Voltage values are with respect to network ground terminal.

recommended operating conditions

	SN54S'			SN74S'			UNIT		
	MIN	NOM	MAX	MIN	NOM	MAX			
Supply voltage, V_{CC}	4.5	5	5.5	4.75	5	5.25	V		
High-level output voltage, V_{OH}			5.5			5.5	V		
High-level output current, I_{OH}			-2			-6.5	mA		
Width of clock/enable pulse, t_w	High	6		6			ns		
	Low	7.3		7.3					
Data setup time, t_{su}	'S373	0↓		0↓			ns		
	'S374	5↑		5↑					
Data hold time, t_h	'S373	10↓		10↓			ns		
	'S374	2↑		2↑					
Operating free-air temperature, T_A			-55			125	0	70	°C



POST OFFICE BOX 655303 • DALLAS, TEXAS 75265

SN54LS373, SN54LS374, SN54S373, SN54S374,
SN74LS373, SN74LS374, SN74S373, SN74S374
OCTAL D-TYPE TRANSPARENT LATCHES AND EDGE-TRIGGERED FLIP-FLOPS

SDLS165 – OCTOBER 1975 – REVISED MARCH 1988

electrical characteristics over recommended operating free-air temperature range (unless otherwise noted)

PARAMETER	TEST CONDITIONS†			MIN	TYP‡	MAX	UNIT
V _{IH}				2			V
V _{IL}						0.8	V
V _{IK}	V _{CC} = MIN, I _I = -18 mA					-1.2	V
V _{OH}	SN54S'	V _{CC} = MIN, V _{IH} = 2 V, V _{IL} = 0.8 V, I _{OH} = MAX			2.4	3.4	V
	SN74S'				2.4	3.1	
V _{OL}	V _{CC} = MIN, V _{IH} = 2 V, V _{IL} = 0.8 V, I _{OL} = 20 mA					0.5	V
I _{OZH}	V _{CC} = MAX, V _{IH} = 2 V, V _O = 2.4 V					50	μA
I _{OZL}	V _{CC} = MAX, V _{IH} = 2 V, V _O = 0.5 V					-50	μA
I _I	V _{CC} = MAX, V _I = 5.5 V					1	mA
I _{IH}	V _{CC} = MAX, V _I = 2.7 V					50	μA
I _{IL}	V _{CC} = MAX, V _I = 0.5 V					-250	μA
I _{OS} §	V _{CC} = MAX			-40		-100	mA
I _{CC}	V _{CC} = MAX	'S373	outputs high			160	mA
			outputs low			160	
			outputs disabled			190	
		'S374	outputs high			110	
			outputs low			140	
			outputs disabled			160	
			CLK and OC at 4 V, D inputs at 0 V			180	

†For conditions shown as MIN or MAX, use the appropriate value specified under recommended operating conditions.

‡All typical values are at V_{CC} = 5 V, T_A = 25°C.

§Not more than one output should be shorted at a time and duration of the short-circuit should not exceed one second.

switching characteristics, V_{CC} = 5 V, T_A = 25°C

PARAMETER	FROM (INPUT)	TO (OUTPUT)	TEST CONDITIONS	'S373			'S374			UNIT
				MIN	TYP	MAX	MIN	TYP	MAX	
f _{max}			C _L = 15 pF, R _L = 280 Ω, See Notes 2 and 4				75	100		MHz
t _{PLH}	Data	Any Q		7	12					ns
t _{PHL}		Any Q		7	12					ns
t _{PLH}	Clock or enable	Any Q		7	14	8	15			ns
t _{PHL}		Any Q		12	18	11	17			ns
t _{PZH}	Output	Any Q		8	15	8	15			ns
t _{PZL}	Control		11	18	11	18			ns	
t _{PHZ}	Output	Any Q	C _L = 5 pF, R _L = 280 Ω, See Note 3	6	9	5	9		ns	
t _{PLZ}				Control	8	12	7	12		ns

NOTES: 2. Maximum clock frequency is tested with all outputs loaded.

4. Load circuits and voltage waveforms are shown in Section 1.

f_{max} = maximum clock frequency

t_{PLH} = propagation delay time, low-to-high-level output

t_{PHL} = propagation delay time, high-to-low-level output

t_{PZH} = output enable time to high level

t_{PZL} = output enable time to low level

t_{PHZ} = output disable time from high level

t_{PLZ} = output disable time from low level



**SN54LS373, SN54LS374, SN54S373, SN54S374,
SN74LS373, SN74LS374, SN74S373, SN74S374**
OCTAL D-TYPE TRANSPARENT LATCHES AND EDGE-TRIGGERED FLIP-FLOPS

SDLS165 – OCTOBER 1975 – REVISED MARCH 1988

TYPICAL APPLICATION DATA

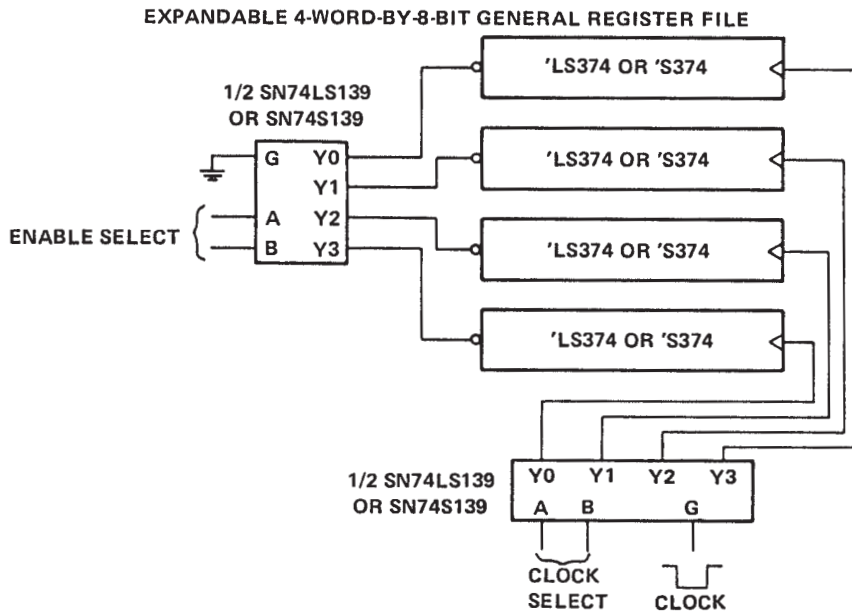
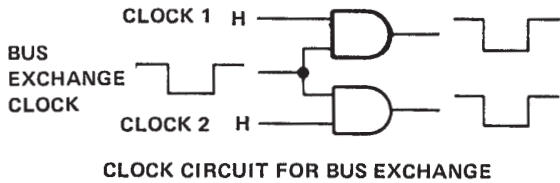
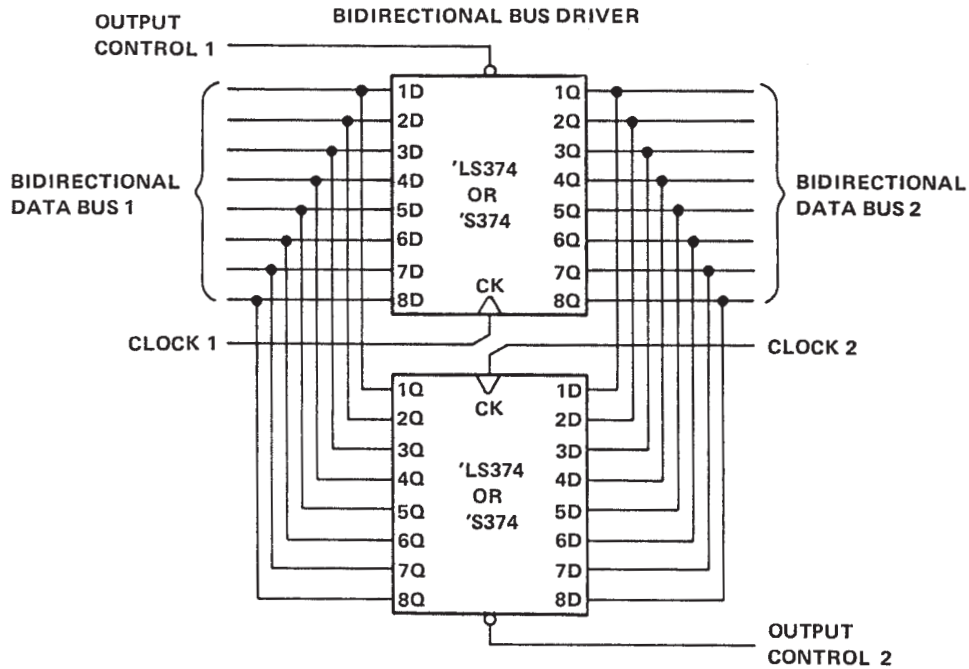

IMPORTANT NOTICE

Texas Instruments and its subsidiaries (TI) reserve the right to make changes to their products or to discontinue any product or service without notice, and advise customers to obtain the latest version of relevant information to verify, before placing orders, that information being relied on is current and complete. All products are sold subject to the terms and conditions of sale supplied at the time of order acknowledgement, including those pertaining to warranty, patent infringement, and limitation of liability.

TI warrants performance of its semiconductor products to the specifications applicable at the time of sale in accordance with TI's standard warranty. Testing and other quality control techniques are utilized to the extent TI deems necessary to support this warranty. Specific testing of all parameters of each device is not necessarily performed, except those mandated by government requirements.

CERTAIN APPLICATIONS USING SEMICONDUCTOR PRODUCTS MAY INVOLVE POTENTIAL RISKS OF DEATH, PERSONAL INJURY, OR SEVERE PROPERTY OR ENVIRONMENTAL DAMAGE ("CRITICAL APPLICATIONS"). TI SEMICONDUCTOR PRODUCTS ARE NOT DESIGNED, AUTHORIZED, OR WARRANTED TO BE SUITABLE FOR USE IN LIFE-SUPPORT DEVICES OR SYSTEMS OR OTHER CRITICAL APPLICATIONS. INCLUSION OF TI PRODUCTS IN SUCH APPLICATIONS IS UNDERSTOOD TO BE FULLY AT THE CUSTOMER'S RISK.

In order to minimize risks associated with the customer's applications, adequate design and operating safeguards must be provided by the customer to minimize inherent or procedural hazards.

TI assumes no liability for applications assistance or customer product design. TI does not warrant or represent that any license, either express or implied, is granted under any patent right, copyright, mask work right, or other intellectual property right of TI covering or relating to any combination, machine, or process in which such semiconductor products or services might be or are used. TI's publication of information regarding any third party's products or services does not constitute TI's approval, warranty or endorsement thereof.