

# SN54F621, SN74F621 OCTAL BUS TRANSCEIVERS WITH OPEN-COLLECTOR OUTPUTS

SDFS004B – D2932, MARCH 1987 – REVISED OCTOBER 1993

- Local Bus-Latch Capability
- Noninverting Logic
- Package Options Include Plastic Small-Outline Packages, Ceramic Chip Carriers, and Standard Plastic and Ceramic 300-mil DIPs

## description

These octal bus transceivers are designed for asynchronous communication between data buses. The control function implementation allows for maximum flexibility in timing.

These devices allow data transmission from the A bus to the B bus or from the B bus to the A bus depending upon the logic levels at the output enable (OEAB and  $\overline{\text{OEBA}}$ ) inputs.

The output-enable inputs can be used to disable the device so that the buses are effectively isolated. The dual-enable configuration gives the transceivers the capability of storing data by simultaneously enabling OEAB and  $\overline{\text{OEBA}}$ . Each output reinforces its input in this configuration. When both OEAB and  $\overline{\text{OEBA}}$  are enabled and all other data sources to the two sets of bus lines are at high impedance, both sets of bus lines (16 in all) will remain at their last states.

The SN54F621 is characterized for operation over the full military temperature range of  $-55^{\circ}\text{C}$  to  $125^{\circ}\text{C}$ . The SN74F621 is characterized for operation from  $0^{\circ}\text{C}$  to  $70^{\circ}\text{C}$ .

SN54F621 . . . J PACKAGE  
SN74F621 . . . DW OR N PACKAGE  
(TOP VIEW)

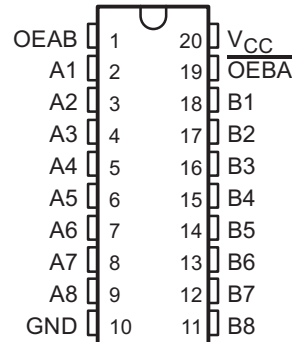

SN54F621 . . . FK PACKAGE  
(TOP VIEW)

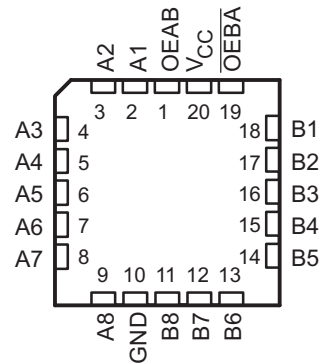

FUNCTION TABLE

INPUTS		OPERATION
$\overline{\text{OEBA}}$	OEAB	
L	L	B data to A bus
L	H	B data to A bus, A data to B bus
H	L	Isolation
H	H	A data to B bus

# SN54F621, SN74F621 OCTAL BUS TRANSCEIVERS WITH OPEN-COLLECTOR OUTPUTS

SDFS004B – D2932, MARCH 1987 – REVISED OCTOBER 1993

## logic symbol†

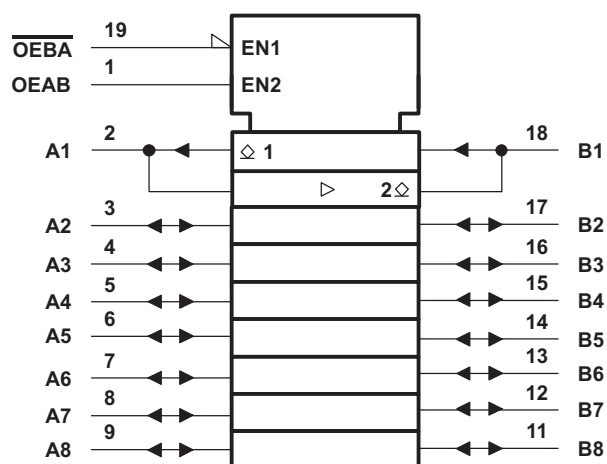

## logic diagram (positive logic)

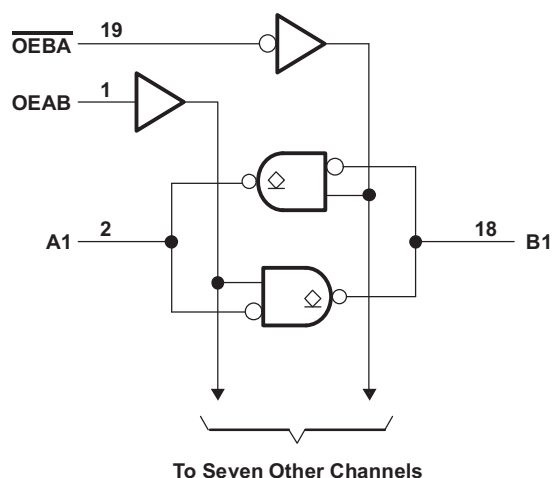

† This symbol is in accordance with ANSI/IEEE Std 91-1984 and IEC Publication 617-12.

## absolute maximum ratings over operating free-air temperature range (unless otherwise noted)‡

Supply voltage range, $V_{CC}$ .....	-0.5 V to 7 V
Input voltage range, $V_I$ (excluding I/O ports) (see Note 1) .....	-1.2 V to 7 V
Input current range, $I_{IK}$ .....	-30 mA to 5 mA
Voltage range applied to any output in the high state .....	-0.5 V to 5.5 V
Current into any output in the low state: SN54F621 (A1–A8) .....	40 mA
SN54F621 (B1–B8) .....	96 mA
SN74F621 (A1–A8) .....	48 mA
SN74F621 (B1–B8) .....	128 mA
Operating free-air temperature range: SN54F621 .....	-55°C to 125°C
SN74F621 .....	0°C to 70°C
Storage temperature range .....	-65°C to 150°C

‡ Stresses beyond those listed under "absolute maximum ratings" may cause permanent damage to the device. These are stress ratings only, and functional operation of the device at these or any other conditions beyond those indicated under "recommended operating conditions" is not implied. Exposure to absolute-maximum-rated conditions for extended periods may affect device reliability.

NOTE 1: The input-voltage ratings may be exceeded provided the input-current ratings are observed.

## recommended operating conditions

		SN54F621			SN74F621			UNIT
		MIN	NOM	MAX	MIN	NOM	MAX	
$V_{CC}$	Supply voltage	4.5	5	5.5	4.5	5	5.5	V
$V_{IH}$	High-level input voltage	2			2			V
$V_{OH}$	High-level output voltage			5.5			5.5	V
$V_{IL}$	Low-level input voltage			0.8			0.8	V
$I_{IK}$	Input clamp current			-18			-18	mA
$I_{OL}$	Low-level output current	A1–A8		20	B1–B8		24	mA
		B1–B8		48	A1–A8		64	
$T_A$	Operating free-air temperature	-55		125	0		70	°C



POST OFFICE BOX 655303 • DALLAS, TEXAS 75265

**SN54F621, SN74F621**  
**OCTAL BUS TRANSCEIVERS**  
**WITH OPEN-COLLECTOR OUTPUTS**  
 SDFS004B – D2932, MARCH 1987 – REVISED OCTOBER 1993

electrical characteristics over recommended operating free-air temperature range (unless otherwise noted)

PARAMETER		TEST CONDITIONS		SN54F621			SN74F621			UNIT
				MIN	TYP†	MAX	MIN	TYP†	MAX	
V <sub>IK</sub>		V <sub>CC</sub> = 4.5 V, I <sub>I</sub> = – 18 mA		– 1.2			– 1.2			V
I <sub>OH</sub>		V <sub>CC</sub> = 4.5 V, V <sub>OH</sub> = 5.5 V		250			250			μA
V <sub>OL</sub>	A1–A8	V <sub>CC</sub> = 4.5 V	I <sub>OL</sub> = 20 mA	0.3 0.5					V	
	B1–B8		I <sub>OL</sub> = 24 mA			0.35 0.5				
			I <sub>OL</sub> = 48 mA	0.38 0.55						
			I <sub>OL</sub> = 64 mA			0.42 0.55				
I <sub>I</sub>	A and B ports	V <sub>CC</sub> = 5.5 V	V <sub>I</sub> = 5.5 V	1		1			mA	
	OEAB or OEBA		V <sub>I</sub> = 7 V	0.1		0.1				
I <sub>IH</sub> ‡	A and B ports	V <sub>CC</sub> = 5.5 V,	V <sub>I</sub> = 2.7 V	70		70			μA	
	OEAB or OEBA			20		20				
I <sub>IL</sub> ‡	A and B ports	V <sub>CC</sub> = 5.5 V,	V <sub>I</sub> = 0.5 V	– 0.65		– 0.65			mA	
	OEAB or OEBA			– 0.6		– 0.6				
I <sub>CCH</sub>		V <sub>CC</sub> = 5.5 V		105 140		105 140		mA		
I <sub>CCL</sub>		V <sub>CC</sub> = 5.5 V		105 140		105 140		mA		

† All typical values are at V<sub>CC</sub> = 5 V, T<sub>A</sub> = 25°C.

‡ For I/O ports, the parameters I<sub>IH</sub> and I<sub>IL</sub> include the off-state output current.

**switching characteristics (see Note 2)**

PARAMETER	FROM (INPUT)	TO (OUTPUT)	V <sub>CC</sub> = 5 V, C <sub>L</sub> = 50 pF, R <sub>L</sub> = 500 Ω, T <sub>A</sub> = 25°C			V <sub>CC</sub> = 4.5 V to 5.5 V, C <sub>L</sub> = 50 pF, R <sub>L</sub> = 500 Ω, T <sub>A</sub> = MIN to MAX§				UNIT
			'F621			SN54F621		SN74F621		
			MIN	TYP	MAX	MIN	MAX	MIN	MAX	
t <sub>PLH</sub>	A	B	6	9.5	12	5.5	13	5.5	13	ns
t <sub>PHL</sub>			2.5	3.8	8	2	8.5	2	8.5	
t <sub>PLH</sub>	B	A	6	9	12	5.5	12.5	5.5	12.5	ns
t <sub>PHL</sub>			2.5	4	7.5	2	8	2	8	
t <sub>PLH</sub>	OEBA	A	6	10	13.5	5.5	14	5.5	14	ns
t <sub>PHL</sub>			3.5	6.5	10.5	2.5	11	2.5	11	
t <sub>PLH</sub>	OEAB	B	7	12	15	6	17	6	17	ns
t <sub>PHL</sub>			3.5	6.5	9.5	3	10	3	10	

§ For conditions shown as MIN or MAX, use the appropriate value specified under recommended operating conditions.

NOTE 2: Load circuits and waveforms are shown in Section 1.





**PACKAGING INFORMATION**

Orderable Device	Status <sup>(1)</sup>	Package Type	Package Drawing	Pins	Package Qty	Eco Plan <sup>(2)</sup>	Lead/Ball Finish	MSL Peak Temp <sup>(3)</sup>
SN54F621J	OBSOLETE	CDIP	J	20		TBD	Call TI	Call TI
SN74F621DW	OBSOLETE	SOIC	DW	20		TBD	Call TI	Call TI
SN74F621DWR	OBSOLETE	SOIC	DW	20		TBD	Call TI	Call TI
SN74F621N	OBSOLETE	PDIP	N	20		TBD	Call TI	Call TI
SNJ54F621FK	OBSOLETE	LCCC	FK	20		TBD	Call TI	Call TI
SNJ54F621J	OBSOLETE	CDIP	J	20		TBD	Call TI	Call TI
SNJ54F621W	OBSOLETE	CFP	W	20		TBD	Call TI	Call TI

<sup>(1)</sup> The marketing status values are defined as follows:

**ACTIVE:** Product device recommended for new designs.

**LIFEBUY:** TI has announced that the device will be discontinued, and a lifetime-buy period is in effect.

**NRND:** Not recommended for new designs. Device is in production to support existing customers, but TI does not recommend using this part in a new design.

**PREVIEW:** Device has been announced but is not in production. Samples may or may not be available.

**OBSOLETE:** TI has discontinued the production of the device.

<sup>(2)</sup> Eco Plan - The planned eco-friendly classification: Pb-Free (RoHS), Pb-Free (RoHS Exempt), or Green (RoHS & no Sb/Br) - please check <http://www.ti.com/productcontent> for the latest availability information and additional product content details.

**TBD:** The Pb-Free/Green conversion plan has not been defined.

**Pb-Free (RoHS):** TI's terms "Lead-Free" or "Pb-Free" mean semiconductor products that are compatible with the current RoHS requirements for all 6 substances, including the requirement that lead not exceed 0.1% by weight in homogeneous materials. Where designed to be soldered at high temperatures, TI Pb-Free products are suitable for use in specified lead-free processes.

**Pb-Free (RoHS Exempt):** This component has a RoHS exemption for either 1) lead-based flip-chip solder bumps used between the die and package, or 2) lead-based die adhesive used between the die and leadframe. The component is otherwise considered Pb-Free (RoHS compatible) as defined above.

**Green (RoHS & no Sb/Br):** TI defines "Green" to mean Pb-Free (RoHS compatible), and free of Bromine (Br) and Antimony (Sb) based flame retardants (Br or Sb do not exceed 0.1% by weight in homogeneous material)

<sup>(3)</sup> MSL, Peak Temp. -- The Moisture Sensitivity Level rating according to the JEDEC industry standard classifications, and peak solder temperature.

**Important Information and Disclaimer:**The information provided on this page represents TI's knowledge and belief as of the date that it is provided. TI bases its knowledge and belief on information provided by third parties, and makes no representation or warranty as to the accuracy of such information. Efforts are underway to better integrate information from third parties. TI has taken and continues to take reasonable steps to provide representative and accurate information but may not have conducted destructive testing or chemical analysis on incoming materials and chemicals. TI and TI suppliers consider certain information to be proprietary, and thus CAS numbers and other limited information may not be available for release.

In no event shall TI's liability arising out of such information exceed the total purchase price of the TI part(s) at issue in this document sold by TI to Customer on an annual basis.

J (R-GDIP-T\*\*)

14 LEADS SHOWN

CERAMIC DUAL IN-LINE PACKAGE

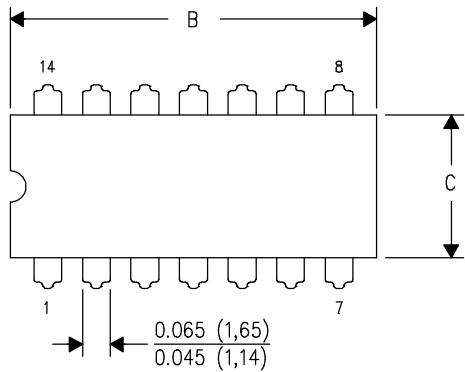

DIM \ PINS **	14	16	18	20
A	0.300 (7,62) BSC	0.300 (7,62) BSC	0.300 (7,62) BSC	0.300 (7,62) BSC
B MAX	0.785 (19,94)	.840 (21,34)	0.960 (24,38)	1.060 (26,92)
B MIN	—	—	—	—
C MAX	0.300 (7,62)	0.300 (7,62)	0.310 (7,87)	0.300 (7,62)
C MIN	0.245 (6,22)	0.245 (6,22)	0.220 (5,59)	0.245 (6,22)

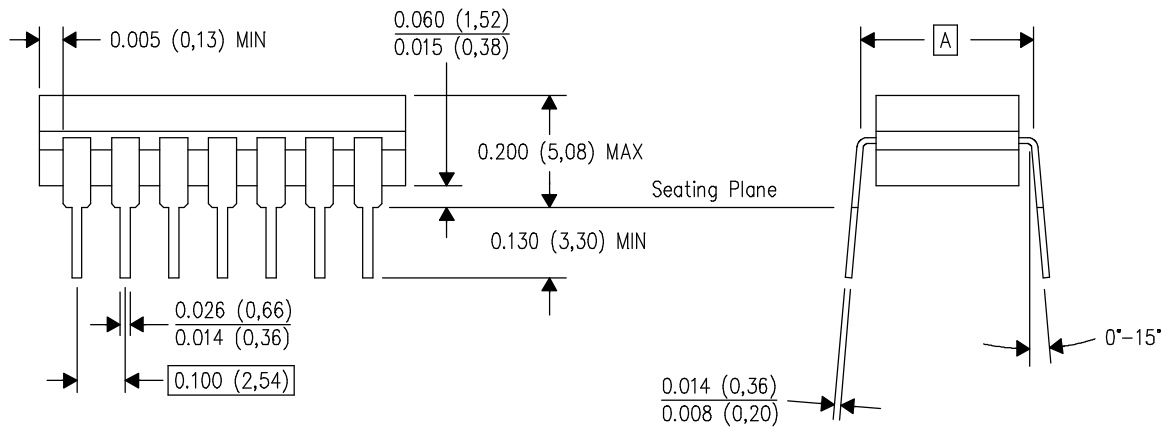

4040083/F 03/03

- NOTES:
- A. All linear dimensions are in inches (millimeters).
  - B. This drawing is subject to change without notice.
  - C. This package is hermetically sealed with a ceramic lid using glass frit.
  - D. Index point is provided on cap for terminal identification only on press ceramic glass frit seal only.
  - E. Falls within MIL STD 1835 GDIP1-T14, GDIP1-T16, GDIP1-T18 and GDIP1-T20.

MECHANICAL DATA

W (R-GDFP-F20)

CERAMIC DUAL FLATPACK

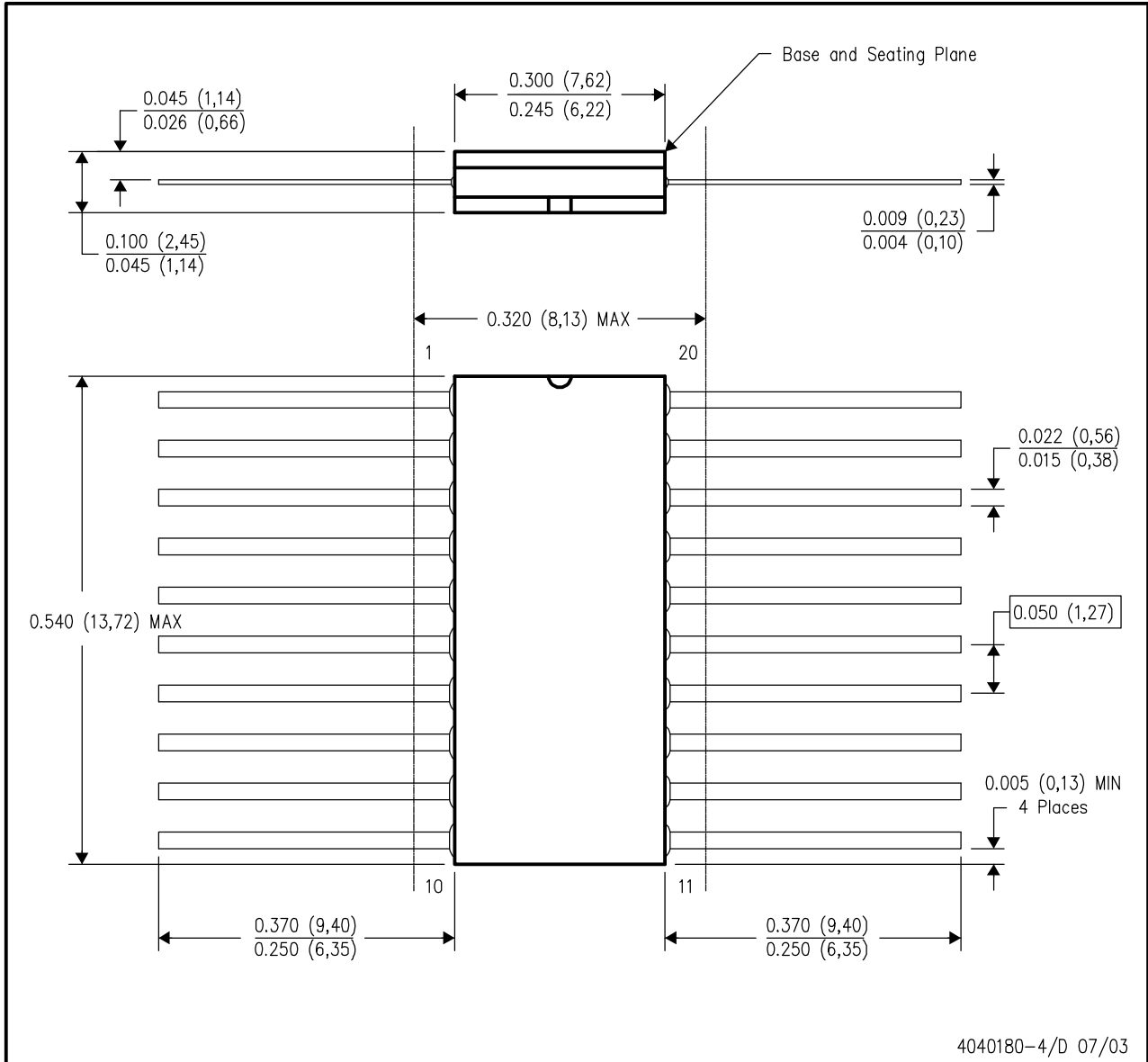

- NOTES:
- A. All linear dimensions are in inches (millimeters).
  - B. This drawing is subject to change without notice.
  - C. This package can be hermetically sealed with a ceramic lid using glass frit.
  - D. Index point is provided on cap for terminal identification only.
  - E. Falls within Mil-Std 1835 GDFP2-F20

# MECHANICAL DATA

FK (S-CQCC-N\*\*)

LEADLESS CERAMIC CHIP CARRIER

28 TERMINAL SHOWN

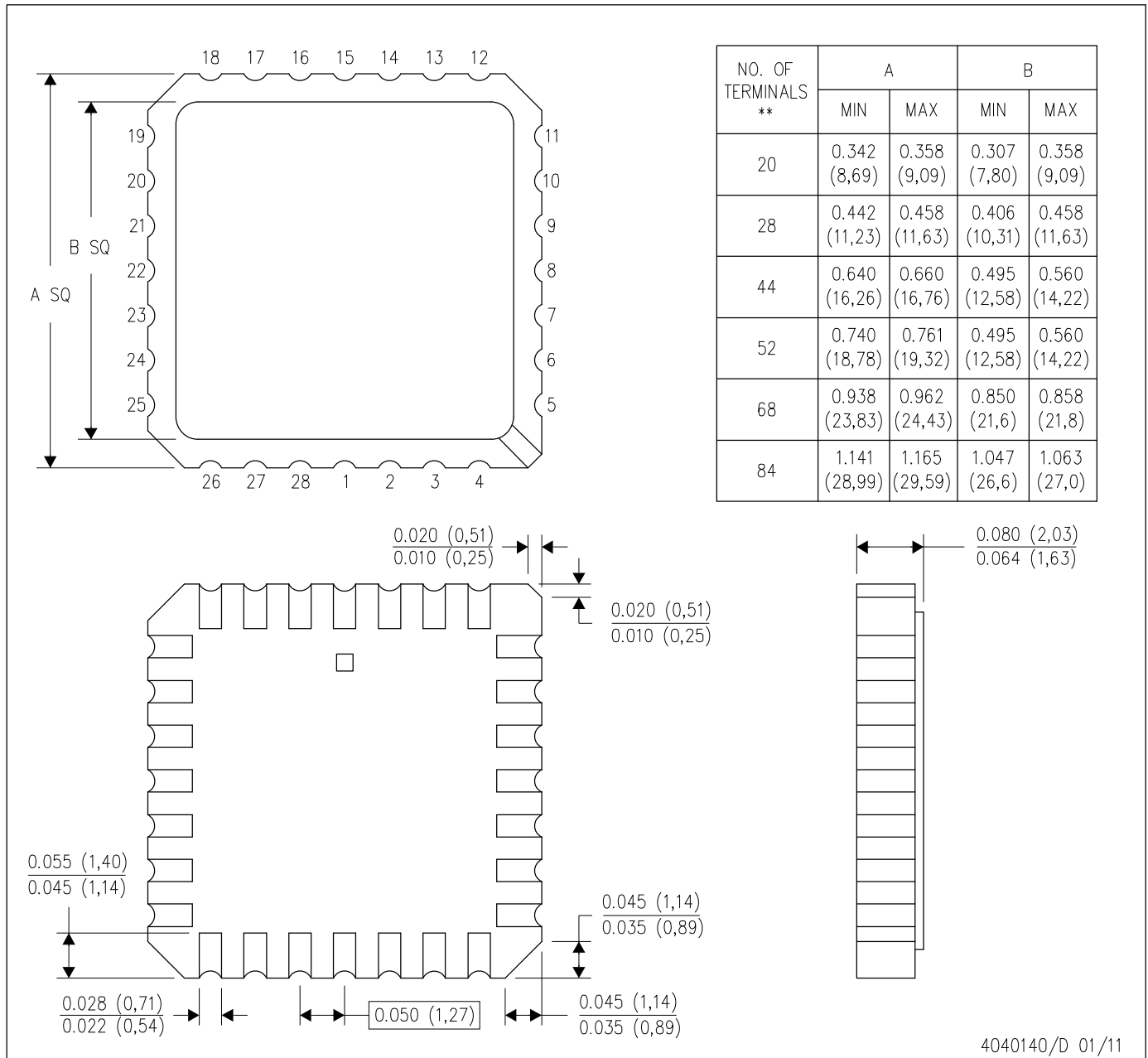

- NOTES:
- All linear dimensions are in inches (millimeters).
  - This drawing is subject to change without notice.
  - This package can be hermetically sealed with a metal lid.
  - Falls within JEDEC MS-004

# MECHANICAL DATA

## N (R-PDIP-T\*\*)

16 PINS SHOWN

## PLASTIC DUAL-IN-LINE PACKAGE

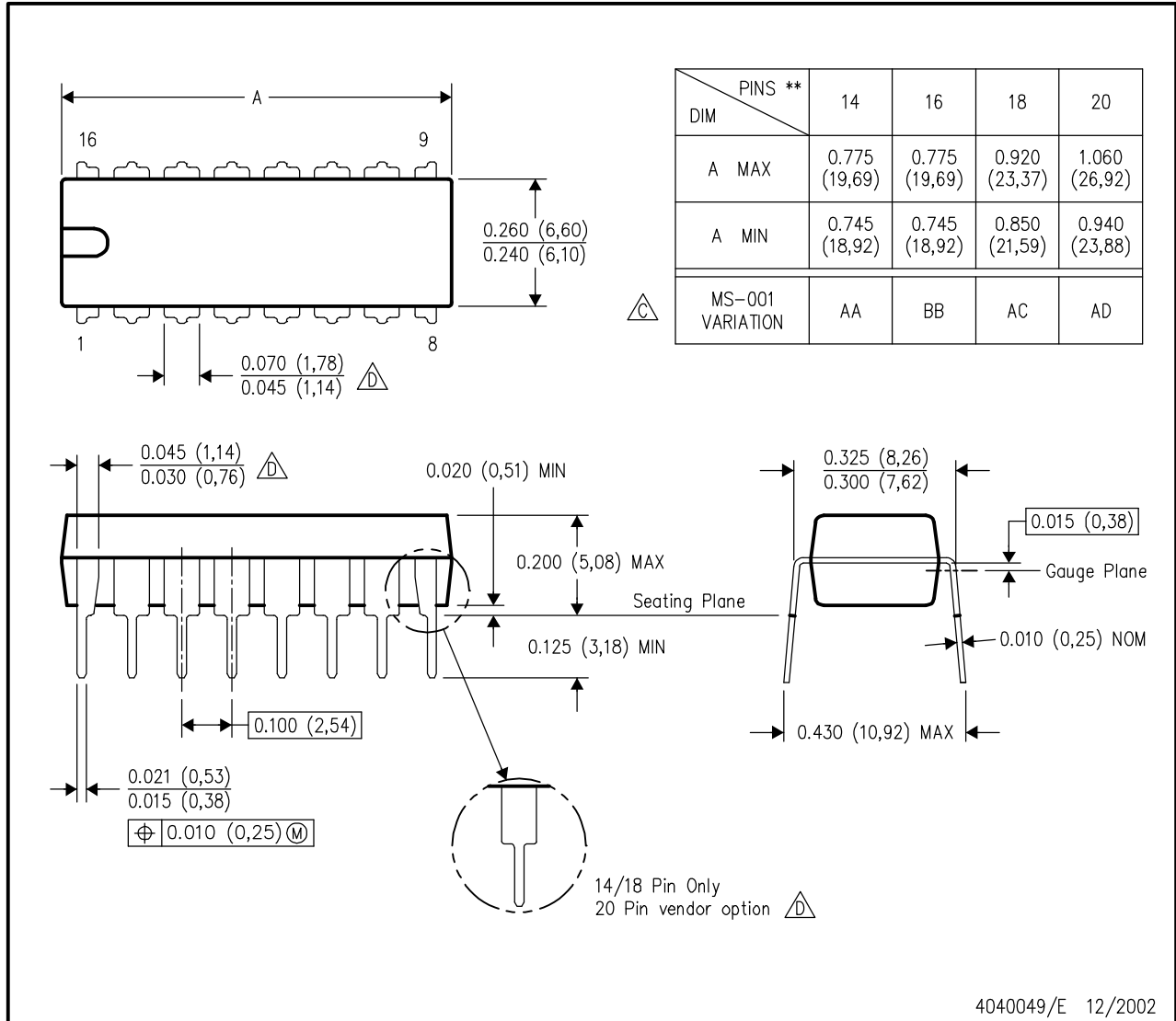

- NOTES:
- A. All linear dimensions are in inches (millimeters).
  - B. This drawing is subject to change without notice.
  - Falls within JEDEC MS-001, except 18 and 20 pin minimum body length (Dim A).
  - The 20 pin end lead shoulder width is a vendor option, either half or full width.

# MECHANICAL DATA

DW (R-PDSO-G20)

PLASTIC SMALL OUTLINE

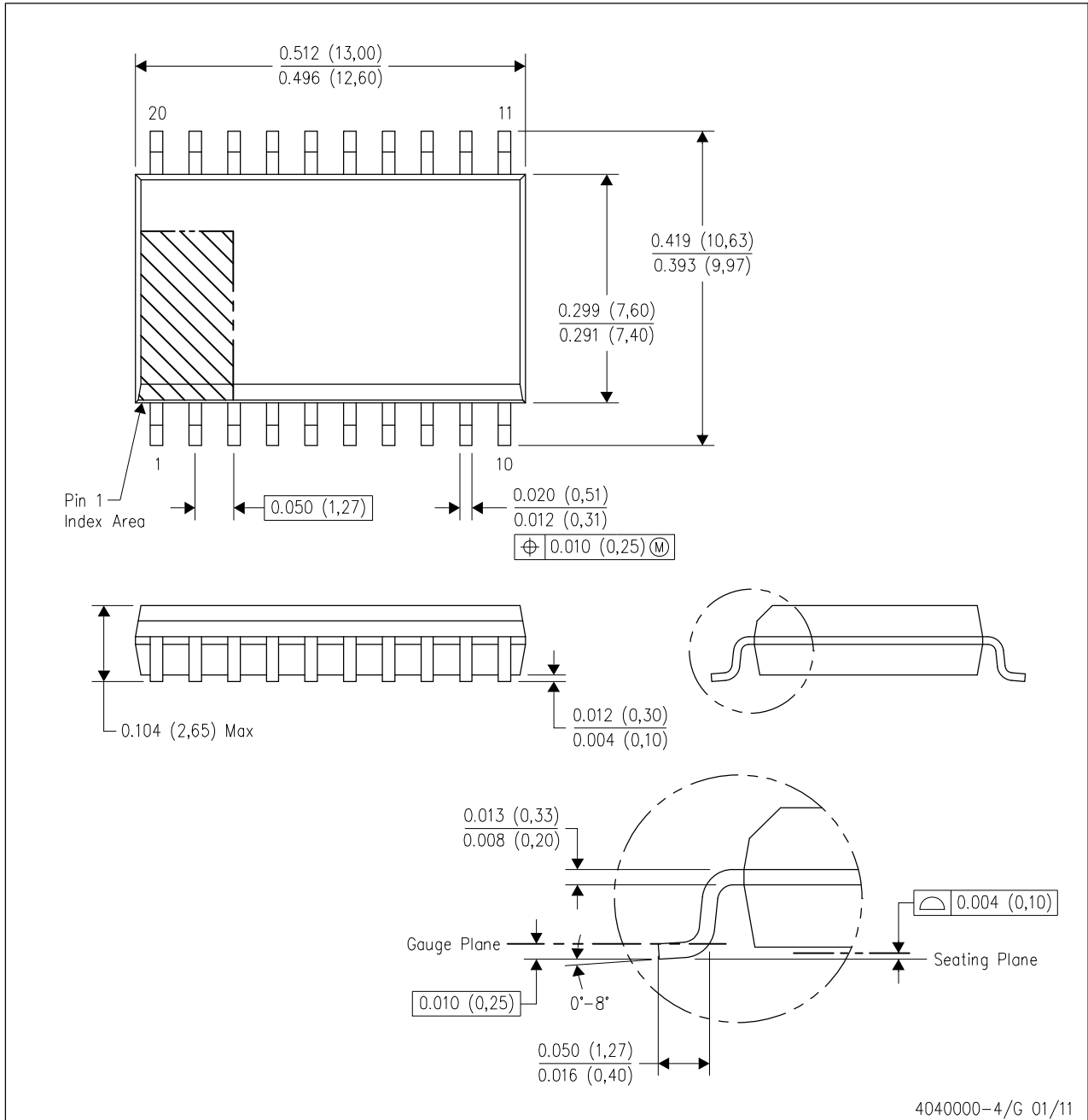

- NOTES:
- All linear dimensions are in inches (millimeters). Dimensioning and tolerancing per ASME Y14.5M-1994.
  - This drawing is subject to change without notice.
  - Body dimensions do not include mold flash or protrusion not to exceed 0.006 (0,15).
  - Falls within JEDEC MS-013 variation AC.

## IMPORTANT NOTICE

Texas Instruments Incorporated and its subsidiaries (TI) reserve the right to make corrections, modifications, enhancements, improvements, and other changes to its products and services at any time and to discontinue any product or service without notice. Customers should obtain the latest relevant information before placing orders and should verify that such information is current and complete. All products are sold subject to TI's terms and conditions of sale supplied at the time of order acknowledgment.

TI warrants performance of its hardware products to the specifications applicable at the time of sale in accordance with TI's standard warranty. Testing and other quality control techniques are used to the extent TI deems necessary to support this warranty. Except where mandated by government requirements, testing of all parameters of each product is not necessarily performed.

TI assumes no liability for applications assistance or customer product design. Customers are responsible for their products and applications using TI components. To minimize the risks associated with customer products and applications, customers should provide adequate design and operating safeguards.

TI does not warrant or represent that any license, either express or implied, is granted under any TI patent right, copyright, mask work right, or other TI intellectual property right relating to any combination, machine, or process in which TI products or services are used. Information published by TI regarding third-party products or services does not constitute a license from TI to use such products or services or a warranty or endorsement thereof. Use of such information may require a license from a third party under the patents or other intellectual property of the third party, or a license from TI under the patents or other intellectual property of TI.

Reproduction of TI information in TI data books or data sheets is permissible only if reproduction is without alteration and is accompanied by all associated warranties, conditions, limitations, and notices. Reproduction of this information with alteration is an unfair and deceptive business practice. TI is not responsible or liable for such altered documentation. Information of third parties may be subject to additional restrictions.

Resale of TI products or services with statements different from or beyond the parameters stated by TI for that product or service voids all express and any implied warranties for the associated TI product or service and is an unfair and deceptive business practice. TI is not responsible or liable for any such statements.

TI products are not authorized for use in safety-critical applications (such as life support) where a failure of the TI product would reasonably be expected to cause severe personal injury or death, unless officers of the parties have executed an agreement specifically governing such use. Buyers represent that they have all necessary expertise in the safety and regulatory ramifications of their applications, and acknowledge and agree that they are solely responsible for all legal, regulatory and safety-related requirements concerning their products and any use of TI products in such safety-critical applications, notwithstanding any applications-related information or support that may be provided by TI. Further, Buyers must fully indemnify TI and its representatives against any damages arising out of the use of TI products in such safety-critical applications.

TI products are neither designed nor intended for use in military/aerospace applications or environments unless the TI products are specifically designated by TI as military-grade or "enhanced plastic." Only products designated by TI as military-grade meet military specifications. Buyers acknowledge and agree that any such use of TI products which TI has not designated as military-grade is solely at the Buyer's risk, and that they are solely responsible for compliance with all legal and regulatory requirements in connection with such use.

TI products are neither designed nor intended for use in automotive applications or environments unless the specific TI products are designated by TI as compliant with ISO/TS 16949 requirements. Buyers acknowledge and agree that, if they use any non-designated products in automotive applications, TI will not be responsible for any failure to meet such requirements.

Following are URLs where you can obtain information on other Texas Instruments products and application solutions:

<b>Products</b>		<b>Applications</b>	
Audio	<a href="http://www.ti.com/audio">www.ti.com/audio</a>	Communications and Telecom	<a href="http://www.ti.com/communications">www.ti.com/communications</a>
Amplifiers	<a href="http://amplifier.ti.com">amplifier.ti.com</a>	Computers and Peripherals	<a href="http://www.ti.com/computers">www.ti.com/computers</a>
Data Converters	<a href="http://dataconverter.ti.com">dataconverter.ti.com</a>	Consumer Electronics	<a href="http://www.ti.com/consumer-apps">www.ti.com/consumer-apps</a>
DLP® Products	<a href="http://www.dlp.com">www.dlp.com</a>	Energy and Lighting	<a href="http://www.ti.com/energy">www.ti.com/energy</a>
DSP	<a href="http://dsp.ti.com">dsp.ti.com</a>	Industrial	<a href="http://www.ti.com/industrial">www.ti.com/industrial</a>
Clocks and Timers	<a href="http://www.ti.com/clocks">www.ti.com/clocks</a>	Medical	<a href="http://www.ti.com/medical">www.ti.com/medical</a>
Interface	<a href="http://interface.ti.com">interface.ti.com</a>	Security	<a href="http://www.ti.com/security">www.ti.com/security</a>
Logic	<a href="http://logic.ti.com">logic.ti.com</a>	Space, Avionics and Defense	<a href="http://www.ti.com/space-avionics-defense">www.ti.com/space-avionics-defense</a>
Power Mgmt	<a href="http://power.ti.com">power.ti.com</a>	Transportation and Automotive	<a href="http://www.ti.com/automotive">www.ti.com/automotive</a>
Microcontrollers	<a href="http://microcontroller.ti.com">microcontroller.ti.com</a>	Video and Imaging	<a href="http://www.ti.com/video">www.ti.com/video</a>
RFID	<a href="http://www.ti-rfid.com">www.ti-rfid.com</a>	Wireless	<a href="http://www.ti.com/wireless-apps">www.ti.com/wireless-apps</a>
RF/IF and ZigBee® Solutions	<a href="http://www.ti.com/lprf">www.ti.com/lprf</a>		
	<b>TI E2E Community Home Page</b>		<a href="http://e2e.ti.com">e2e.ti.com</a>

Mailing Address: Texas Instruments, Post Office Box 655303, Dallas, Texas 75265  
Copyright © 2011, Texas Instruments Incorporated