

SN54F253, SN74F253 DUAL 1-OF-4 DATA SELECTORS/MULTIPLEXERS WITH 3-STATE OUTPUTS

SDFS064A – D2032, MARCH 1987 – REVISED OCTOBER 1993

- 3-State Versions of SN54F153 and SN74F153
- Permits Multiplexing From N Lines to One Line
- Performs Parallel-to-Serial Conversion
- Package Options Include Plastic Small-Outline Packages, Ceramic Chip Carriers, and Standard Plastic and Ceramic 300-mil DIPs

description

These data selectors/multiplexers contain inverters and drivers to supply full binary decoding data selection to the AND-OR gates. Separate output-control inputs are provided for each of the two 4-line sections.

The 3-state outputs can interface with and drive data lines of bus-organized systems. With all but one of the common outputs disabled (at a high-impedance state), the low impedance of the single enabled output will drive the bus line to a high or low logic level. Each output has its own strobe (\overline{G}) inputs. The output is disabled when its strobe is high.

The SN54F253 is characterized for operation over the full military temperature range of -55°C to 125°C . The SN74F253 is characterized for operation from 0°C to 70°C .

SN54F253 . . . J PACKAGE
SN74F253 . . . D OR N PACKAGE
(TOP VIEW)

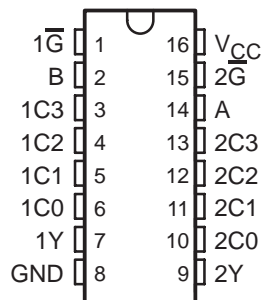

SN54F253 . . . FK PACKAGE
(TOP VIEW)

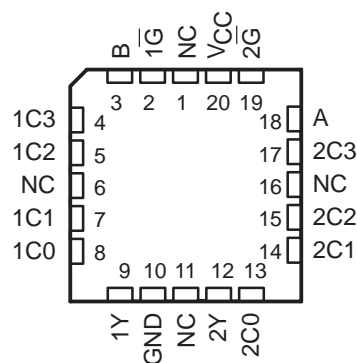

NC – No internal connection

FUNCTION TABLE

INPUTS						STROBE \overline{G}	OUTPUT Y
SELECT		DATA					
B	A	C0	C1	C2	C3		
X	X	X	X	X	X	H	Z
L	L	L	X	X	X	L	L
L	L	H	X	X	X	L	H
L	H	X	L	X	X	L	L
L	H	X	H	X	X	L	H
H	L	X	X	L	X	L	L
H	L	X	X	H	X	L	H
H	H	X	X	X	L	L	L
H	H	X	X	X	H	L	H

Select inputs A and B are common to both sections.

SN54F253, SN74F253 DUAL 1-OF-4 DATA SELECTORS/MULTIPLEXERS WITH 3-STATE OUTPUTS

SDFS064A – D2032, MARCH 1987 – REVISED OCTOBER 1993

logic symbol†

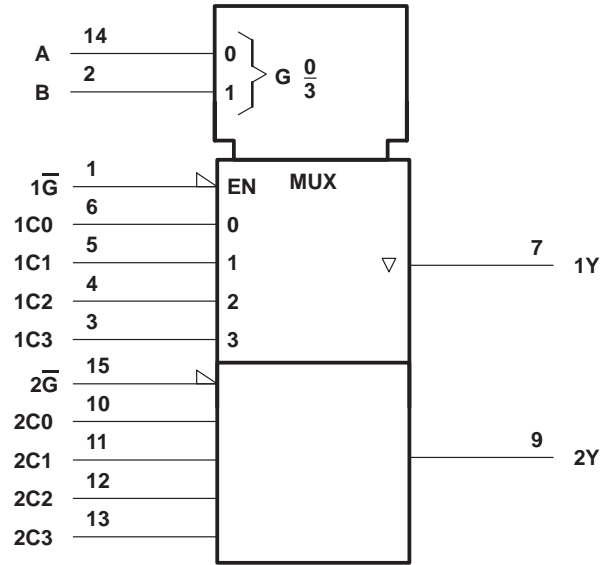

† This symbol is in accordance with ANSI/IEEE Std 91-1984 and IEC Publication 617-12.
Pin numbers shown are for the D, J, and N packages.

SN54F253, SN74F253 DUAL 1-OF-4 DATA SELECTORS/MULTIPLEXERS WITH 3-STATE OUTPUTS

SDFS064A – D2032, MARCH 1987 – REVISED OCTOBER 1993

logic diagram (positive logic)

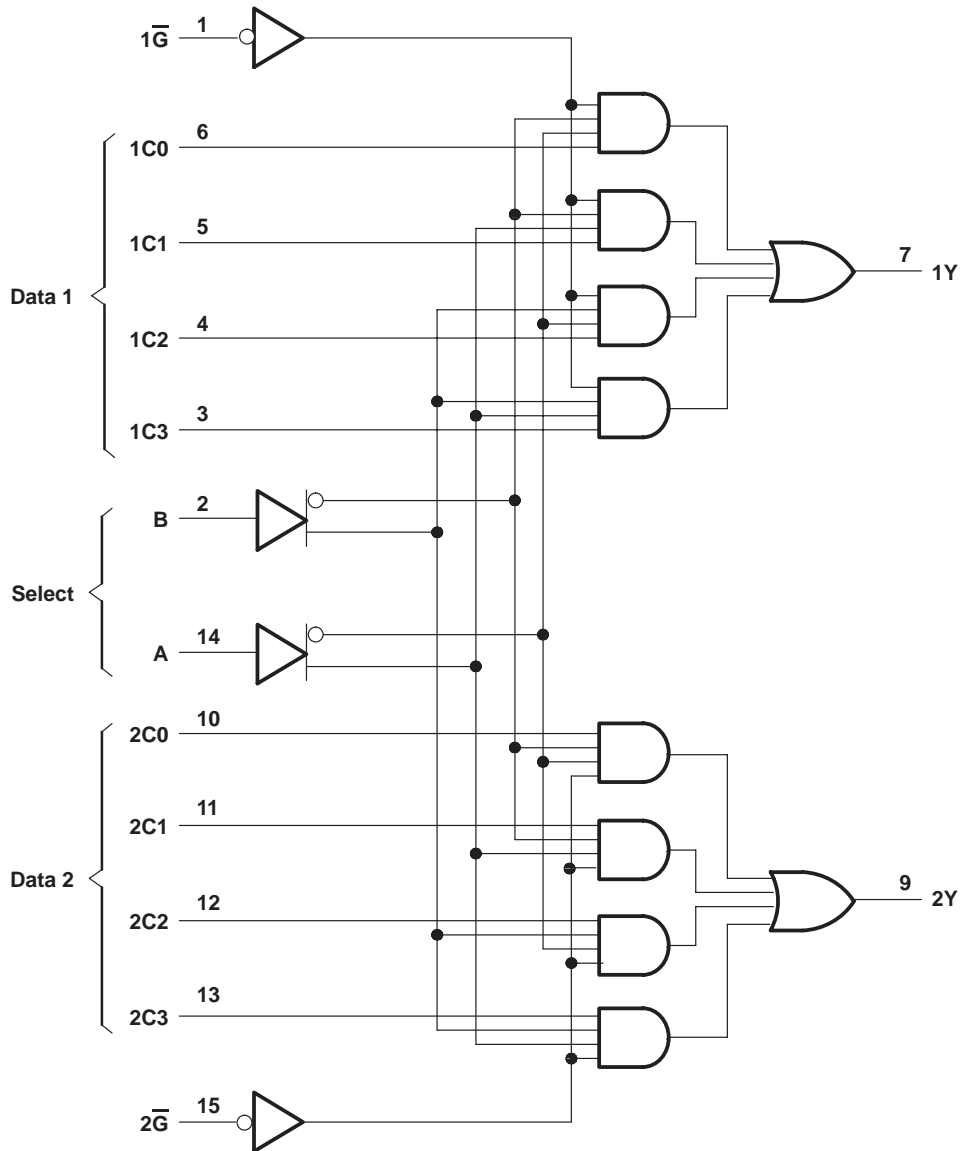

Pin numbers shown are for the D, J, and N packages.



SN54F253, SN74F253 DUAL 1-OF-4 DATA SELECTORS/MULTIPLEXERS WITH 3-STATE OUTPUTS

SDFS064A – D2032, MARCH 1987 – REVISED OCTOBER 1993

absolute maximum ratings over operating free-air temperature range (unless otherwise noted)†

Supply voltage range, V_{CC}	–0.5 V to 7 V
Input voltage range (see Note 1)	–1.2 V to 7 V
Input current range	–30 mA to 5 mA
Voltage range applied to any output in the disabled or power-off state	–0.5 V to 5.5 V
Voltage range applied to any output in the high state	–0.5 V to V_{CC}
Current into any output in the low state: SN54F253	40 mA
SN74F253	48 mA
Operating free-air temperature range: SN54F253	–55°C to 125°C
SN74F253	0°C to 70°C
Storage temperature range	–65°C to 150°C

† Stresses beyond those listed under “absolute maximum ratings” may cause permanent damage to the device. These are stress ratings only and functional operation of the device at these or any other conditions beyond those indicated under “recommended operating conditions” is not implied. Exposure to absolute-maximum-rated conditions for extended periods may affect device reliability.

NOTE 1: The input voltage ratings may be exceeded provided the input current ratings are observed.

recommended operating conditions

	SN54F253			SN74F253			UNIT
	MIN	NOM	MAX	MIN	NOM	MAX	
V_{CC} Supply voltage	4.5	5	5.5	4.5	5	5.5	V
V_{IH} High-level input voltage	2			2			V
V_{IL} Low-level input voltage			0.8			0.8	V
I_{IK} Input clamp current			–18			–18	mA
I_{OH} High-level output current			–3			–3	mA
I_{OL} Low-level output current			20			24	mA
T_A Operating free-air temperature	–55		125	0		70	°C

SN54F253, SN74F253 DUAL 1-OF-4 DATA SELECTORS/MULTIPLEXERS WITH 3-STATE OUTPUTS

SDFS064A – D2032, MARCH 1987 – REVISED OCTOBER 1993

electrical characteristics over recommended operating free-air temperature range (unless otherwise noted)

PARAMETER	TEST CONDITIONS		SN54F253			SN74F253			UNIT
			MIN	TYP†	MAX	MIN	TYP†	MAX	
V_{IK}	$V_{CC} = 4.5 V$,	$I_I = -18 mA$			-1.2			-1.2	V
V_{OH}	$V_{CC} = 4.5 V$	$I_{OH} = -1 mA$	2.5	3.4		2.5	3.4		V
		$I_{OH} = -3 mA$	2.4	3.3		2.4	3.3		
V_{OL}	$V_{CC} = 4.75 V$,	$I_{OH} = -1 mA$ to $-3 mA$				2.7			V
		$V_{CC} = 4.5 V$			0.3	0.5			
I_{OZH}	$V_{CC} = 5.5 V$,	$V_O = 2.7 V$			50			50	μA
					-50			-50	
I_{OZL}	$V_{CC} = 5.5 V$,	$V_O = 0.5 V$			-50			-50	μA
I_I	$V_{CC} = 5.5 V$,	$V_I = 7 V$			0.1			0.1	mA
I_{IH}	$V_{CC} = 5.5 V$,	$V_I = 2.7 V$			20			20	μA
I_{IL}	$V_{CC} = 5.5 V$,	$V_I = 0.5 V$			-0.6			-0.6	mA
I_{OS}^\ddagger	$V_{CC} = 5.5 V$,	$V_O = 0$	-60		-150	-60		-150	mA
I_{CCH}	$V_{CC} = 5.5 V$, See Note 2	Condition A		11.5	16		11.5	16	mA
I_{CCL}		Condition B		16	23		16	23	
I_{CCZ}		Condition C		16	23		16	23	

† All typical values are at $V_{CC} = 5 V$, $T_A = 25^\circ C$.

‡ Not more than one output should be shorted at a time, and the duration of the short circuit should not exceed one second.

NOTE 2: I_{CC} is measured with the outputs open under the following conditions:

- A. Inputs A, B, 1C3, and 2C3 at 4.5 V, other inputs grounded
- B. All inputs grounded
- C. Inputs 1 \bar{G} and 2 \bar{G} at 4.5 V, other inputs grounded

switching characteristics (see Note 3)

PARAMETER	FROM (INPUT)	TO (OUTPUT)	$V_{CC} = 5 V$, $C_L = 50 pF$, $R_1 = 500 \Omega$, $R_2 = 500 \Omega$, $T_A = 25^\circ C$			$V_{CC} = 4.5 V$ to $5.5 V$, $C_L = 50 pF$, $R_1 = 500 \Omega$, $R_2 = 500 \Omega$, $T_A = MIN$ to MAX^\S			UNIT	
			'F253			SN54F253		SN74F253		
			MIN	TYP	MAX	MIN	MAX	MIN		MAX
t_{PLH}	A or B	Any Y	3.7	8.1	11.5	2.7	15	3.7	13	ns
t_{PHL}			2.2	6.1	9	1.7	11	2.2	10	
t_{PLH}	Any C	Any Y	2.2	5.1	7	1.7	9	2.2	8	ns
t_{PHL}			1.7	4.1	6	1.7	8	1.7	7	
t_{PZH}	\bar{G}	Any Y	2.2	5.6	8	1.7	10	2.2	9	ns
t_{PZL}			2.2	5.6	8	1.7	10	2.2	9	
t_{PHZ}	\bar{G}	Any Y	1.2	3.3	5	1.2	6.5	1.2	6	ns
t_{PLZ}			1.2	4	6	1.2	8	1.2	7	

§ For conditions shown as MIN or MAX, use the appropriate value specified under recommended operating conditions.

NOTE 3: Load circuit and waveforms are shown in Section 1.



TAPE AND REEL INFORMATION

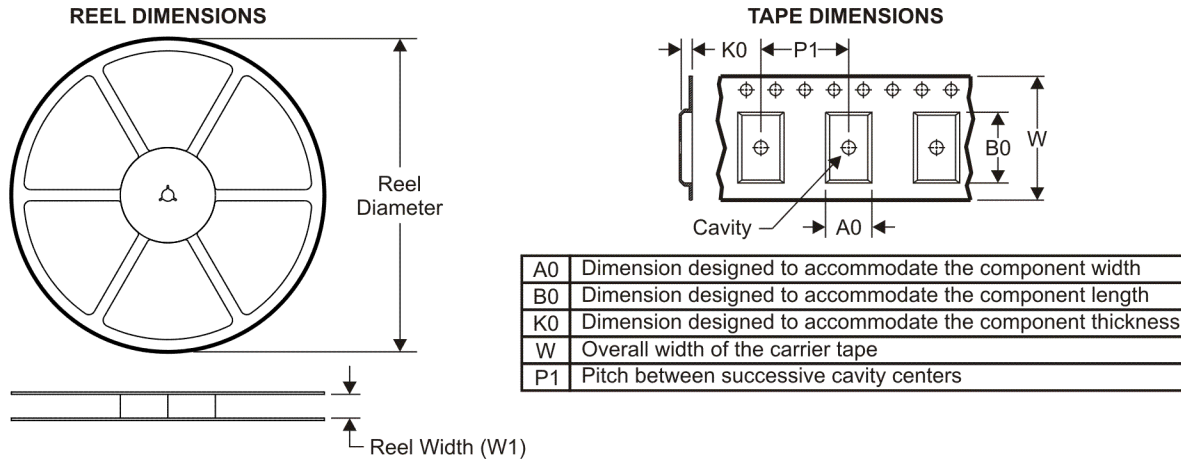

QUADRANT ASSIGNMENTS FOR PIN 1 ORIENTATION IN TAPE

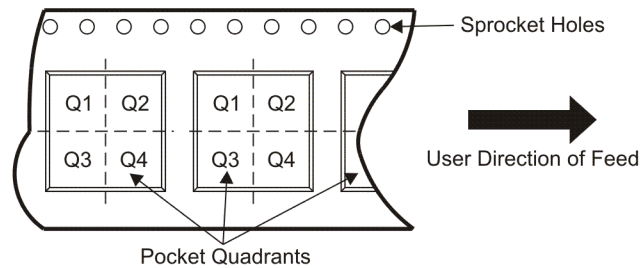

*All dimensions are nominal

Device	Package Type	Package Drawing	Pins	SPQ	Reel Diameter (mm)	Reel Width W1 (mm)	A0 (mm)	B0 (mm)	K0 (mm)	P1 (mm)	W (mm)	Pin1 Quadrant
SN74F253DR	SOIC	D	16	2500	330.0	16.4	6.5	10.3	2.1	8.0	16.0	Q1

TAPE AND REEL BOX DIMENSIONS

*All dimensions are nominal

Device	Package Type	Package Drawing	Pins	SPQ	Length (mm)	Width (mm)	Height (mm)
SN74F253DR	SOIC	D	16	2500	333.2	345.9	28.6

IMPORTANT NOTICE

Texas Instruments Incorporated and its subsidiaries (TI) reserve the right to make corrections, modifications, enhancements, improvements, and other changes to its products and services at any time and to discontinue any product or service without notice. Customers should obtain the latest relevant information before placing orders and should verify that such information is current and complete. All products are sold subject to TI's terms and conditions of sale supplied at the time of order acknowledgment.

TI warrants performance of its hardware products to the specifications applicable at the time of sale in accordance with TI's standard warranty. Testing and other quality control techniques are used to the extent TI deems necessary to support this warranty. Except where mandated by government requirements, testing of all parameters of each product is not necessarily performed.

TI assumes no liability for applications assistance or customer product design. Customers are responsible for their products and applications using TI components. To minimize the risks associated with customer products and applications, customers should provide adequate design and operating safeguards.

TI does not warrant or represent that any license, either express or implied, is granted under any TI patent right, copyright, mask work right, or other TI intellectual property right relating to any combination, machine, or process in which TI products or services are used. Information published by TI regarding third-party products or services does not constitute a license from TI to use such products or services or a warranty or endorsement thereof. Use of such information may require a license from a third party under the patents or other intellectual property of the third party, or a license from TI under the patents or other intellectual property of TI.

Reproduction of TI information in TI data books or data sheets is permissible only if reproduction is without alteration and is accompanied by all associated warranties, conditions, limitations, and notices. Reproduction of this information with alteration is an unfair and deceptive business practice. TI is not responsible or liable for such altered documentation. Information of third parties may be subject to additional restrictions.

Resale of TI products or services with statements different from or beyond the parameters stated by TI for that product or service voids all express and any implied warranties for the associated TI product or service and is an unfair and deceptive business practice. TI is not responsible or liable for any such statements.

TI products are not authorized for use in safety-critical applications (such as life support) where a failure of the TI product would reasonably be expected to cause severe personal injury or death, unless officers of the parties have executed an agreement specifically governing such use. Buyers represent that they have all necessary expertise in the safety and regulatory ramifications of their applications, and acknowledge and agree that they are solely responsible for all legal, regulatory and safety-related requirements concerning their products and any use of TI products in such safety-critical applications, notwithstanding any applications-related information or support that may be provided by TI. Further, Buyers must fully indemnify TI and its representatives against any damages arising out of the use of TI products in such safety-critical applications.

TI products are neither designed nor intended for use in military/aerospace applications or environments unless the TI products are specifically designated by TI as military-grade or "enhanced plastic." Only products designated by TI as military-grade meet military specifications. Buyers acknowledge and agree that any such use of TI products which TI has not designated as military-grade is solely at the Buyer's risk, and that they are solely responsible for compliance with all legal and regulatory requirements in connection with such use.

TI products are neither designed nor intended for use in automotive applications or environments unless the specific TI products are designated by TI as compliant with ISO/TS 16949 requirements. Buyers acknowledge and agree that, if they use any non-designated products in automotive applications, TI will not be responsible for any failure to meet such requirements.

Following are URLs where you can obtain information on other Texas Instruments products and application solutions:

Products		Applications	
Amplifiers	amplifier.ti.com	Audio	www.ti.com/audio
Data Converters	dataconverter.ti.com	Automotive	www.ti.com/automotive
DLP® Products	www.dlp.com	Communications and Telecom	www.ti.com/communications
DSP	dsp.ti.com	Computers and Peripherals	www.ti.com/computers
Clocks and Timers	www.ti.com/clocks	Consumer Electronics	www.ti.com/consumer-apps
Interface	interface.ti.com	Energy	www.ti.com/energy
Logic	logic.ti.com	Industrial	www.ti.com/industrial
Power Mgmt	power.ti.com	Medical	www.ti.com/medical
Microcontrollers	microcontroller.ti.com	Security	www.ti.com/security
RFID	www.ti-rfid.com	Space, Avionics & Defense	www.ti.com/space-avionics-defense
RF/IF and ZigBee® Solutions	www.ti.com/lprf	Video and Imaging	www.ti.com/video
		Wireless	www.ti.com/wireless-apps

Mailing Address: Texas Instruments, Post Office Box 655303, Dallas, Texas 75265
Copyright © 2010, Texas Instruments Incorporated