

SN74BCT2414

MEMORY DECODER

WITH ON-CHIP SUPPLY VOLTAGE MONITOR

SCBS059B – MARCH 1989 – REVISED NOVEMBER 1993

logic symbol†

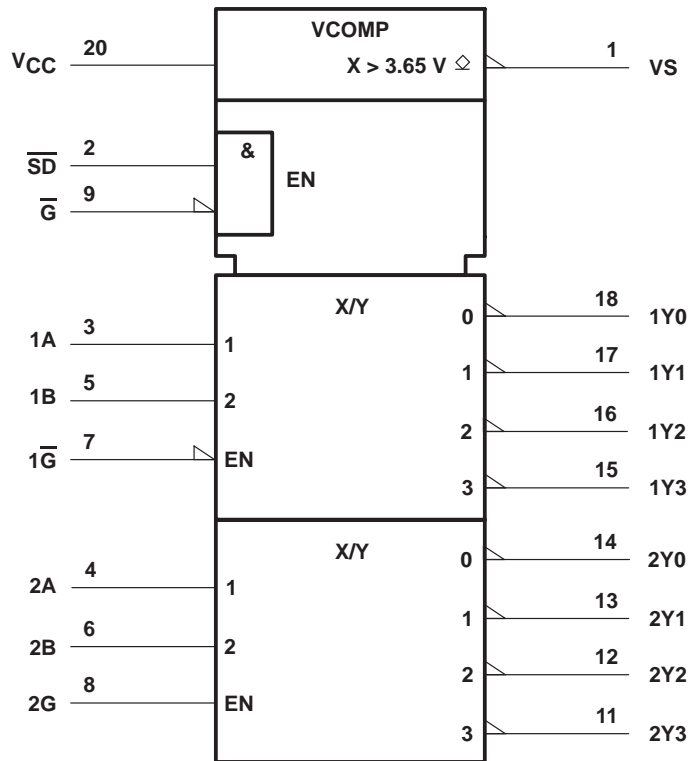

† This symbol is in accordance with ANSI/IEEE Std 91-1984 and IEC Publication 617-12.

logic diagram (positive logic)

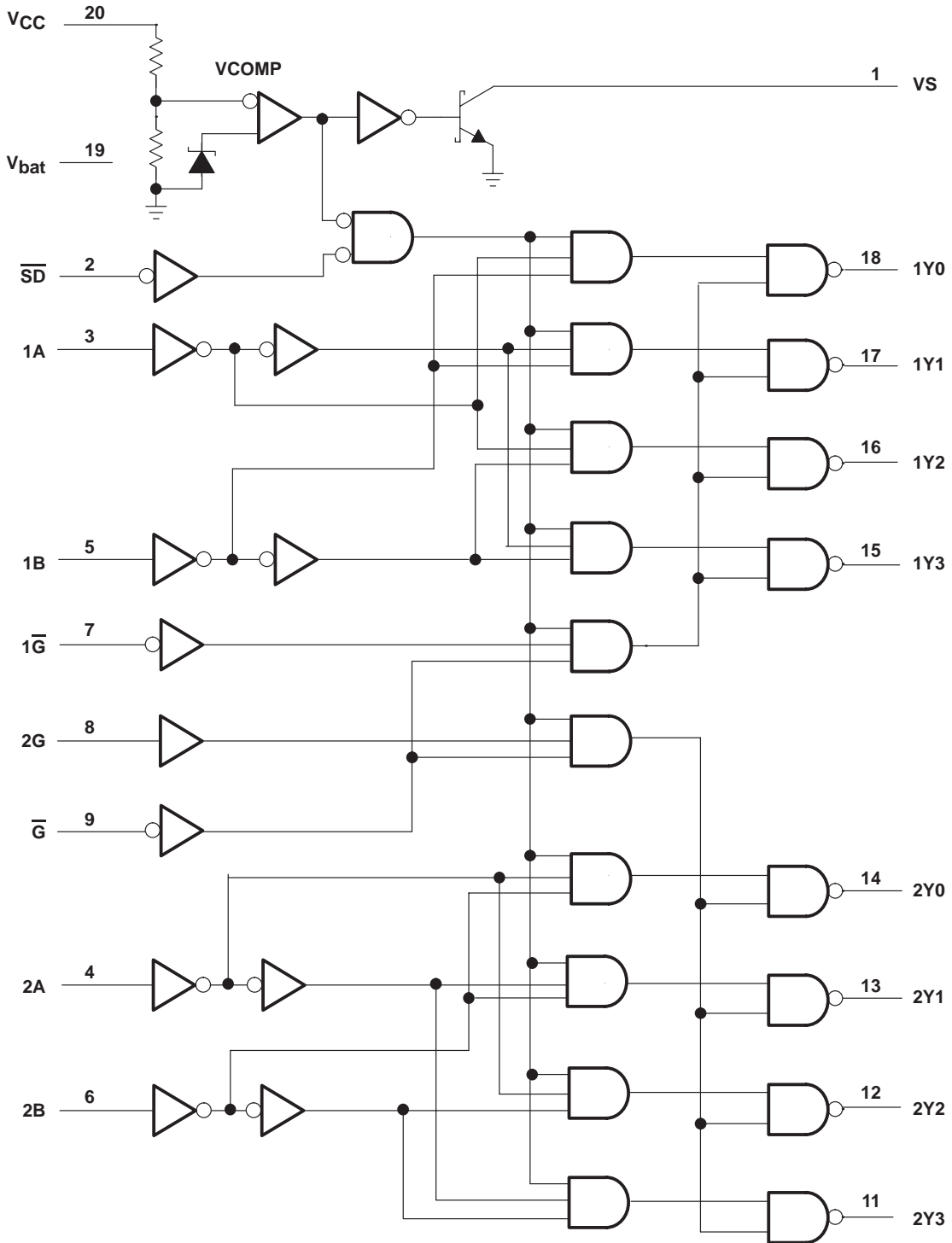

SN74BCT2414
MEMORY DECODER
WITH ON-CHIP SUPPLY VOLTAGE MONITOR

SCBS059B – MARCH 1989 – REVISED NOVEMBER 1993

FUNCTION TABLES

INPUTS					OUTPUTS			
CONTROL			SELECT					
\overline{G}	$1\overline{G}$	\overline{SD}	1B	1A	1Y0	1Y1	1Y2	1Y3
H	X	X	X	X	H	H	H	H
X	H	X	X	X	H	H	H	H
X	X	L	X	X	H	H	H	H
L	L	H	L	L	L	H	H	H
L	L	H	L	H	H	L	H	H
L	L	H	H	L	H	H	L	H
L	L	H	H	H	H	H	H	L

INPUTS					OUTPUTS			
CONTROL			SELECT					
\overline{G}	2G	\overline{SD}	2B	2A	2Y0	2Y1	2Y2	2Y3
H	X	X	X	X	H	H	H	H
X	H	X	X	X	H	H	H	H
X	X	L	X	X	H	H	H	H
L	H	H	L	L	L	H	H	H
L	H	H	L	H	H	L	H	H
L	H	H	H	L	H	H	L	H
L	H	H	H	H	H	H	H	L

NOTE: For a 3-line to 8-line decoder, the following pins must be shorted: $1\overline{G}$ to 2G, 1A to 2A and 1B to 2B.

absolute maximum ratings over operating free-air temperature range (unless otherwise noted)†

Supply voltage range, V_{bat}	-0.5 V to 7 V
Supply voltage range, V_{CC}	-0.5 V to 7 V
Supply voltage V_{CC} with respect to V_{bat}	-1.5 V
Input voltage range, V_I	-0.5 V to $V_{CC} + 0.5$ V
Off-state output voltage range at V_S	-0.5 V to 7 V
Voltage range applied to any Y output in the power-off state	-0.5 V to 7 V
Voltage applied to any Y output in the power-off state with respect to V_{bat}	0.5 V
Operating free-air temperature range	0°C to 70°C
Storage temperature range	-65°C to 150°C

† Stresses beyond those listed under "absolute maximum ratings" may cause permanent damage to the device. These are stress ratings only, and functional operation of the device at these or any other conditions beyond those indicated under "recommended operating conditions" is not implied. Exposure to absolute-maximum-rated conditions for extended periods may affect device reliability

SN74BCT2414
MEMORY DECODER
WITH ON-CHIP SUPPLY VOLTAGE MONITOR

SCBS059B – MARCH 1989 – REVISED NOVEMBER 1993

recommended operating conditions

		MIN	NOM	MAX	UNIT
V_{CC}	Supply voltage	4.5	5	5.5	V
V_{bat}	Supply voltage	4.5	5	5.5	V
V_{IH}	High-level input voltage	2			V
V_{IL}	Low-level input voltage			0.8	V
I_{IK}	Input clamp current			-18	mA
I_{OH}	High-level output current			-400	μ A
I_{OL}	Low-level output current	Y outputs		8	mA
		VS outputs		20	
t_t	Input transition time	0		10	ns/V
T_A	Operating free-air temperature	0		70	$^{\circ}$ C

electrical characteristics over recommended operating free-air temperature range (unless otherwise noted)

PARAMETER		TEST CONDITIONS		MIN	TYP†	MAX	UNIT	
V_{IK}		$V_{CC} = 4.5$ V,	$I_I = -18$ mA			-1.2	V	
V_{OH}		$V_{bat} = V_{CC} = 4.5$ V	$I_{OH} = -20$ μ A	4.4			V	
			$I_{OH} = -400$ μ A	3.5				
		$V_{bat} = 2$ V, $V_{CC} = 0$,	$I_{OH} = -50$ μ A	1.8				
V_{OL}	All except VS	$V_{bat} = V_{CC} = 4.5$ V	$I_{OL} = 4$ mA			0.4	V	
			$I_{OL} = 8$ mA			0.5		
	VS	$V_{bat} = V_{CC} = 4.5$ V,	$I_{OL} = 20$ mA			1		
V_T^{\ddagger}					3.65		V	
I_I		$V_{bat} = V_{CC} = 5.5$ V,	$V_I = 5.5$ V			100	μ A	
I_{IH}		$V_{bat} = V_{CC} = 5.5$ V,	$V_I = 2.7$ V			± 20	μ A	
I_{IL}		$V_{bat} = V_{CC} = 5.5$ V,	$V_I = 0.5$ V			± 20	μ A	
I_{OH}	VS	$V_{bat} = 4.5$ V,	$V_{CC} = 0$			1	μ A	
I_O^{\S}		$V_{bat} = V_{CC} = 5.5$ V,	$V_O = 2.25$ V	-30		-200	mA	
I_{CC}		$V_{bat} = V_{CC} = 5.5$ V	Outputs high			3	mA	
			Outputs low			3		
I_{bat}		$V_{bat} = 2.5$ V,	$V_{CC} = 0$		1	10	μ A	
				Outputs high			20	
	$V_{bat} = V_{CC} = 5.5$ V	Outputs high					3	mA
		Outputs low						
C_i		$V_{bat} = V_{CC} = 5$ V,	$V_I = 0$ or 3 V			4	pF	
C_o	Any Y	$V_{bat} = V_{CC} = 0$				6.5	pF	
	VS					5		

† All typical values are at $V_{CC} = 5$ V, $T_A = 25^{\circ}$ C.

‡ This value represents the V_{CC} monitor threshold voltage. Typical range is from 3.5 V to 3.8 V.

§ This output condition has been chosen to produce a current that closely approximates one half of the short-circuit output current, I_{OS} . Not more than one output should be tested at a time, and the duration of the test should not exceed one second.



SN74BCT2414
MEMORY DECODER
WITH ON-CHIP SUPPLY VOLTAGE MONITOR

SCBS059B – MARCH 1989 – REVISED NOVEMBER 1993

switching characteristics (see Note 1)

PARAMETER	FROM (INPUT)	TO (OUTPUT)	V _{CC} = 5 V, C _L = 50 pF, R1 = 500 Ω, R2 = 500 Ω, T _A = 25°C			V _{CC} = 4.5 V to 5.5 V, C _L = 50 pF, R1 = 500 Ω, R2 = 500 Ω, T _A = MIN to MAX†		UNIT
			MIN	TYP	MAX	MIN	MAX	
t _{PLH}	A or B	Any Y	1	5	10	1	12	ns
t _{PHL}			2	5.8	10	2	12	
t _{PLH}	Any \overline{G}	Any Y	1	4.5	9	1	10	ns
t _{PHL}			2	5.5	9	2	11	
t _{PLH}	\overline{SD}	Any Y	2	6.5	11	2	12	ns
t _{PHL}			2	6.5	11	2	12	

switching characteristics (see Note 1)

PARAMETER	FROM (INPUT)	TO (OUTPUT)	V _{CC} = 5 V, C _L = 50 pF, R1 = 500 Ω, R2 = 500 Ω, T _A = 25°C			V _{CC} = 4.5 V to 5.5 V, C _L = 50 pF, R1 = 500 Ω, R2 = 500 Ω, T _A = MIN to MAX†		UNIT
			MIN	TYP	MAX	MIN	MAX	
t _{PLH}	V _{CC}	Any Y	10	25	50	10	250	ns
t _{PHL}			15	45	100	15	250	
t _{PLH}	V _{CC}	VS	10	28	50	10	250	ns
t _{PHL}			20	50	100	20	250	

† For conditions shown as MIN or MAX, use the appropriate value specified under recommended operating conditions.

NOTE 1: Load circuits and voltage waveforms are shown in Section 1.



APPLICATION INFORMATION

A typical application circuit for a battery-buffered memory in a microcomputer system is shown in Figure 1 which uses the SN74BCT2414. When power fails, the supply-voltage supervisor (TL7705) resets the microcomputer and disables the memory by switching the shutdown input \overline{SD} of the memory decoder to a logic zero. All memory decoder outputs are forced to a logic one. Abnormal write commands from the microprocessor, which may be issued during further voltage breakdown, no longer affect the contents of the memory. When the system supply voltage becomes lower than approximately 3.65 V, the voltage monitor inside the SN74BCT2414 memory decoder disconnects the input buffers of this circuit from the decoding logic internally and keeps all outputs at a logic one. The VS output is also switched off, disconnecting the system supply voltage from the memory circuits. During this low-voltage condition, the memory decoder and the memory circuits are supplied by the battery.

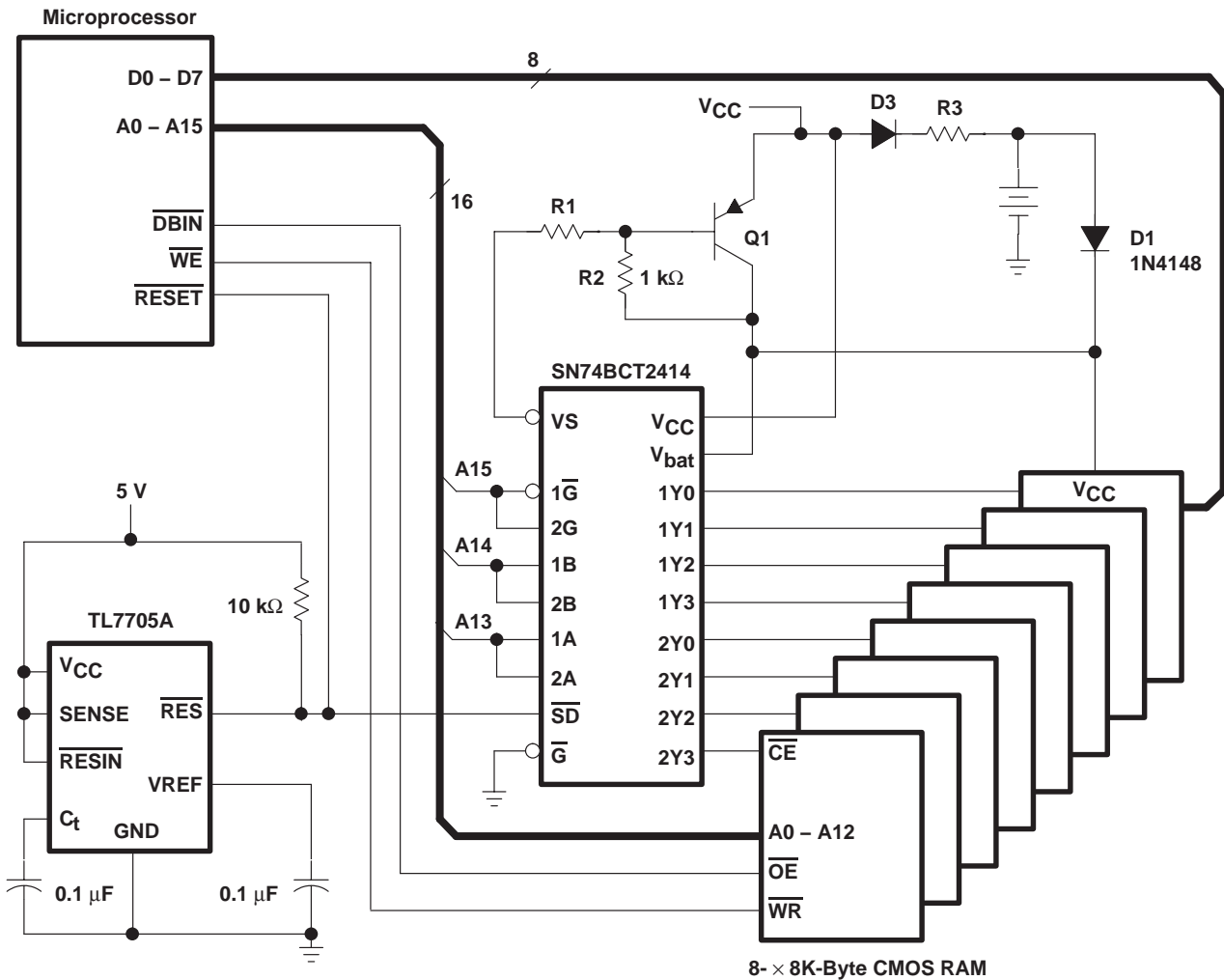

For further information on this device, please contact factory.

Figure 1. Memory System With Battery Backup

PACKAGING INFORMATION

Orderable Device	Status ⁽¹⁾	Package Type	Package Drawing	Pins	Package Qty	Eco Plan ⁽²⁾	Lead/Ball Finish	MSL Peak Temp ⁽³⁾
SN74BCT2414DW	ACTIVE	SOIC	DW	20	25	Green (RoHS & no Sb/Br)	CU NIPDAU	Level-1-260C-UNLIM
SN74BCT2414DWG4	ACTIVE	SOIC	DW	20	25	Green (RoHS & no Sb/Br)	CU NIPDAU	Level-1-260C-UNLIM
SN74BCT2414DWR	ACTIVE	SOIC	DW	20	2000	Green (RoHS & no Sb/Br)	CU NIPDAU	Level-1-260C-UNLIM
SN74BCT2414DWRE4	ACTIVE	SOIC	DW	20	2000	Green (RoHS & no Sb/Br)	CU NIPDAU	Level-1-260C-UNLIM
SN74BCT2414DWRG4	ACTIVE	SOIC	DW	20	2000	Green (RoHS & no Sb/Br)	CU NIPDAU	Level-1-260C-UNLIM
SN74BCT2414N	ACTIVE	PDIP	N	20	20	Pb-Free (RoHS)	CU NIPDAU	N / A for Pkg Type
SN74BCT2414NE4	ACTIVE	PDIP	N	20	20	Pb-Free (RoHS)	CU NIPDAU	N / A for Pkg Type

⁽¹⁾ The marketing status values are defined as follows:

ACTIVE: Product device recommended for new designs.

LIFEBUY: TI has announced that the device will be discontinued, and a lifetime-buy period is in effect.

NRND: Not recommended for new designs. Device is in production to support existing customers, but TI does not recommend using this part in a new design.

PREVIEW: Device has been announced but is not in production. Samples may or may not be available.

OBSELETE: TI has discontinued the production of the device.

⁽²⁾ Eco Plan - The planned eco-friendly classification: Pb-Free (RoHS), Pb-Free (RoHS Exempt), or Green (RoHS & no Sb/Br) - please check <http://www.ti.com/productcontent> for the latest availability information and additional product content details.

TBD: The Pb-Free/Green conversion plan has not been defined.

Pb-Free (RoHS): TI's terms "Lead-Free" or "Pb-Free" mean semiconductor products that are compatible with the current RoHS requirements for all 6 substances, including the requirement that lead not exceed 0.1% by weight in homogeneous materials. Where designed to be soldered at high temperatures, TI Pb-Free products are suitable for use in specified lead-free processes.

Pb-Free (RoHS Exempt): This component has a RoHS exemption for either 1) lead-based flip-chip solder bumps used between the die and package, or 2) lead-based die adhesive used between the die and leadframe. The component is otherwise considered Pb-Free (RoHS compatible) as defined above.

Green (RoHS & no Sb/Br): TI defines "Green" to mean Pb-Free (RoHS compatible), and free of Bromine (Br) and Antimony (Sb) based flame retardants (Br or Sb do not exceed 0.1% by weight in homogeneous material)

⁽³⁾ MSL, Peak Temp. -- The Moisture Sensitivity Level rating according to the JEDEC industry standard classifications, and peak solder temperature.

Important Information and Disclaimer:The information provided on this page represents TI's knowledge and belief as of the date that it is provided. TI bases its knowledge and belief on information provided by third parties, and makes no representation or warranty as to the accuracy of such information. Efforts are underway to better integrate information from third parties. TI has taken and continues to take reasonable steps to provide representative and accurate information but may not have conducted destructive testing or chemical analysis on incoming materials and chemicals. TI and TI suppliers consider certain information to be proprietary, and thus CAS numbers and other limited information may not be available for release.

In no event shall TI's liability arising out of such information exceed the total purchase price of the TI part(s) at issue in this document sold by TI to Customer on an annual basis.

TAPE AND REEL INFORMATION

REEL DIMENSIONS

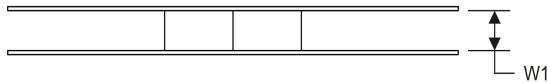
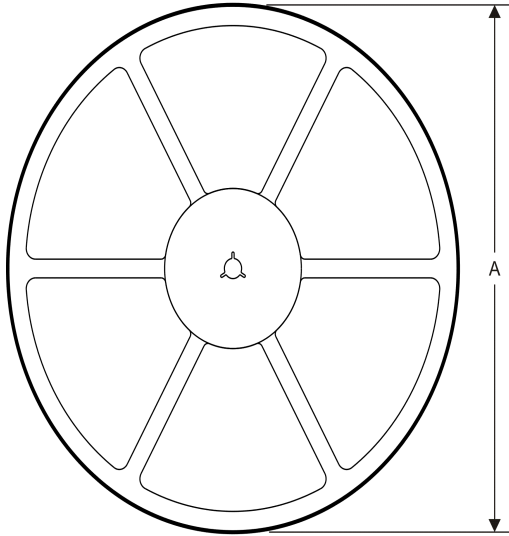

TAPE DIMENSIONS

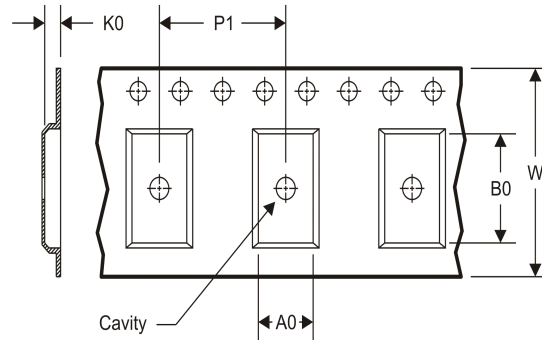

A0	Dimension designed to accommodate the component width
B0	Dimension designed to accommodate the component length
K0	Dimension designed to accommodate the component thickness
W	Overall width of the carrier tape
P1	Pitch between successive cavity centers

TAPE AND REEL INFORMATION

*All dimensions are nominal

Device	Package Type	Package Drawing	Pins	SPQ	Reel Diameter (mm)	Reel Width W1 (mm)	A0 (mm)	B0 (mm)	K0 (mm)	P1 (mm)	W (mm)	Pin1 Quadrant
SN74BCT2414DWR	SOIC	DW	20	2000	330.0	24.4	10.8	13.0	2.7	12.0	24.0	Q1

TAPE AND REEL BOX DIMENSIONS



*All dimensions are nominal

Device	Package Type	Package Drawing	Pins	SPQ	Length (mm)	Width (mm)	Height (mm)
SN74BCT2414DWR	SOIC	DW	20	2000	367.0	367.0	45.0

N (R-PDIP-T**)

PLASTIC DUAL-IN-LINE PACKAGE

16 PINS SHOWN

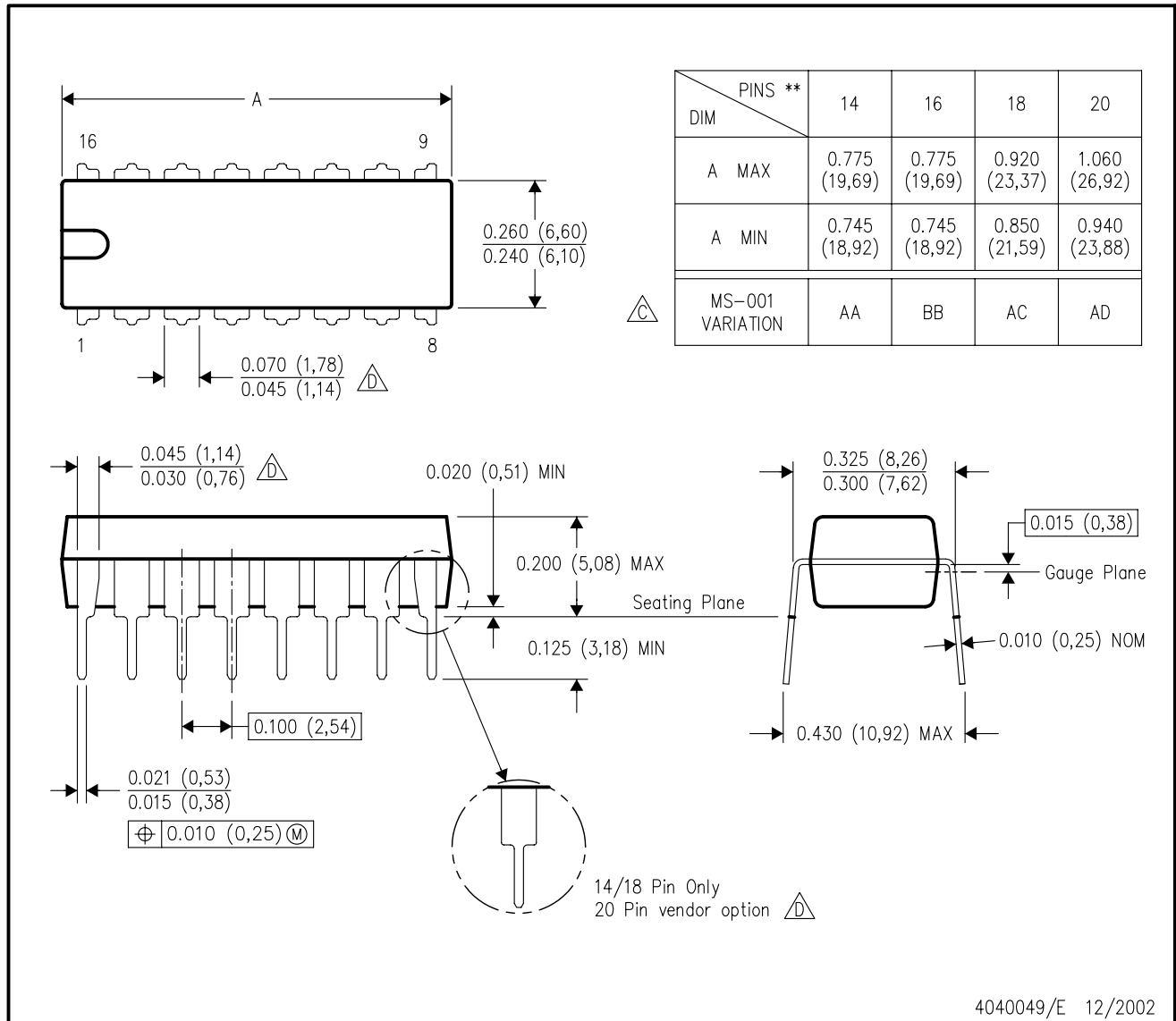

- NOTES:
- A. All linear dimensions are in inches (millimeters).
 - B. This drawing is subject to change without notice.
 - Falls within JEDEC MS-001, except 18 and 20 pin minimum body length (Dim A).
 - The 20 pin end lead shoulder width is a vendor option, either half or full width.

DW (R-PDSO-G20)

PLASTIC SMALL OUTLINE

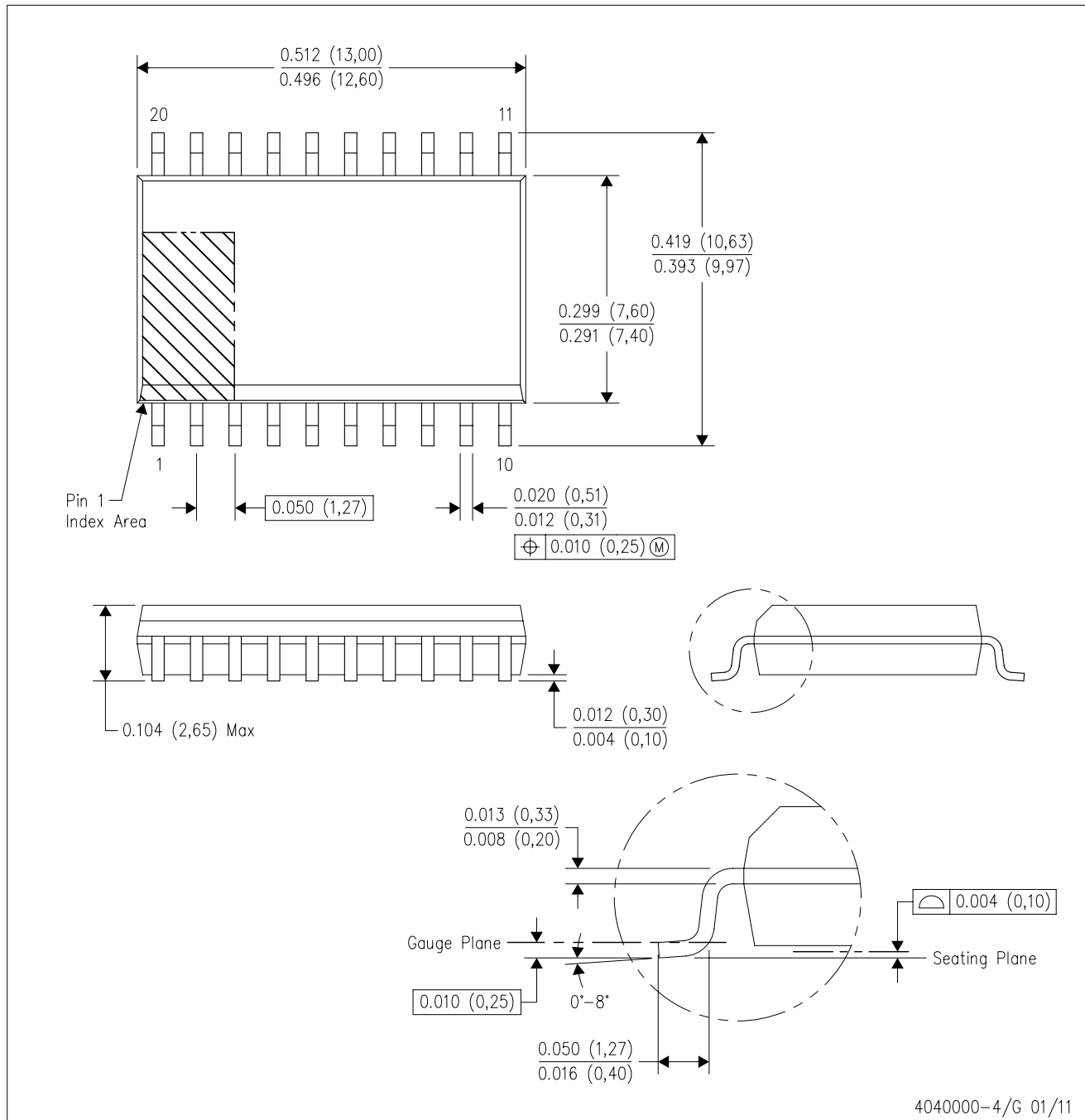

- NOTES:
- All linear dimensions are in inches (millimeters). Dimensioning and tolerancing per ASME Y14.5M-1994.
 - This drawing is subject to change without notice.
 - Body dimensions do not include mold flash or protrusion not to exceed 0.006 (0,15).
 - Falls within JEDEC MS-013 variation AC.

DW (R-PDSO-G20)

PLASTIC SMALL OUTLINE

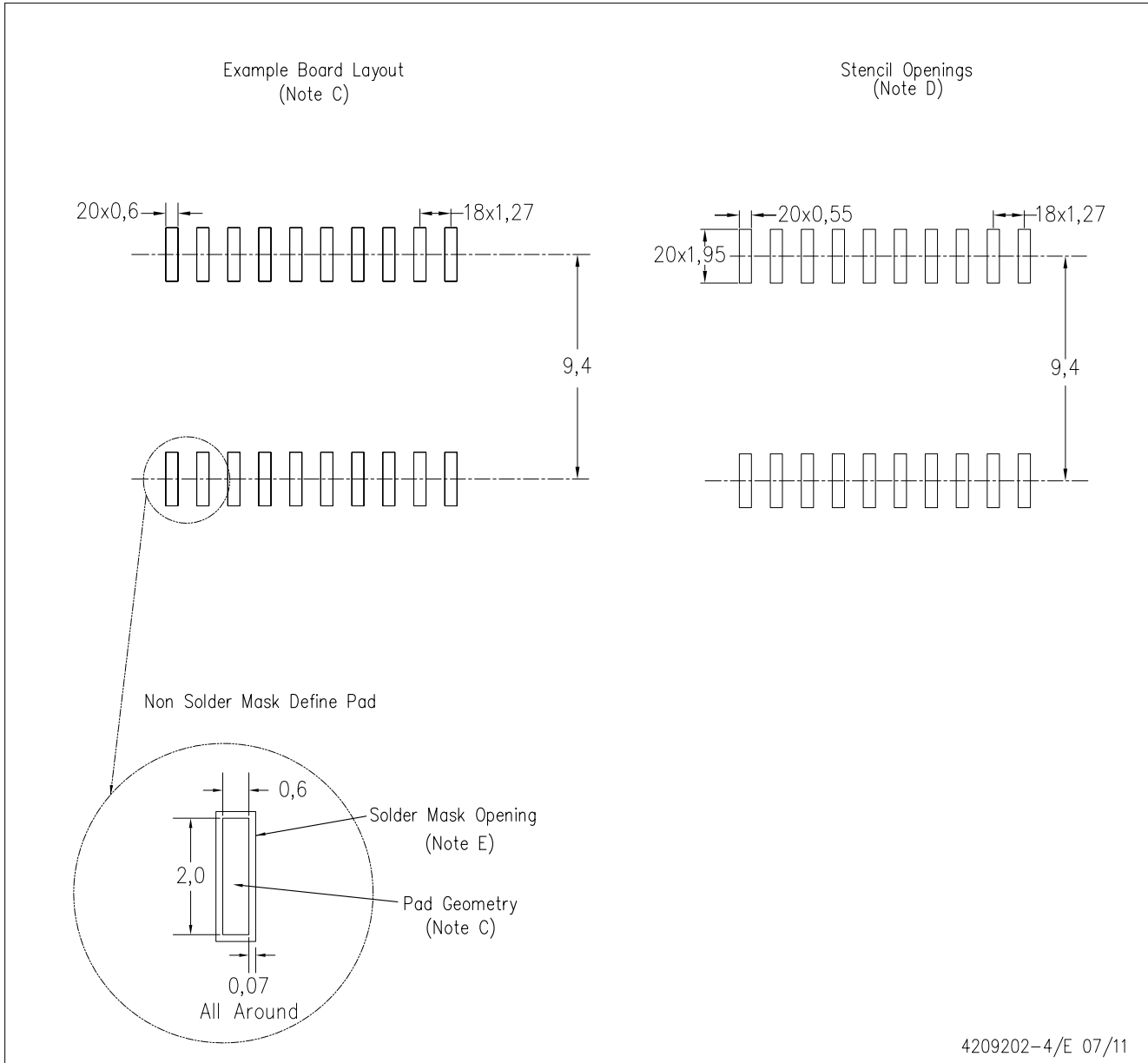

- NOTES:
- A. All linear dimensions are in millimeters.
 - B. This drawing is subject to change without notice.
 - C. Refer to IPC7351 for alternate board design.
 - D. Laser cutting apertures with trapezoidal walls and also rounding corners will offer better paste release. Customers should contact their board assembly site for stencil design recommendations. Refer to IPC-7525
 - E. Customers should contact their board fabrication site for solder mask tolerances between and around signal pads.

IMPORTANT NOTICE

Texas Instruments Incorporated and its subsidiaries (TI) reserve the right to make corrections, enhancements, improvements and other changes to its semiconductor products and services per JESD46C and to discontinue any product or service per JESD48B. Buyers should obtain the latest relevant information before placing orders and should verify that such information is current and complete. All semiconductor products (also referred to herein as "components") are sold subject to TI's terms and conditions of sale supplied at the time of order acknowledgment.

TI warrants performance of its components to the specifications applicable at the time of sale, in accordance with the warranty in TI's terms and conditions of sale of semiconductor products. Testing and other quality control techniques are used to the extent TI deems necessary to support this warranty. Except where mandated by applicable law, testing of all parameters of each component is not necessarily performed.

TI assumes no liability for applications assistance or the design of Buyers' products. Buyers are responsible for their products and applications using TI components. To minimize the risks associated with Buyers' products and applications, Buyers should provide adequate design and operating safeguards.

TI does not warrant or represent that any license, either express or implied, is granted under any patent right, copyright, mask work right, or other intellectual property right relating to any combination, machine, or process in which TI components or services are used. Information published by TI regarding third-party products or services does not constitute a license to use such products or services or a warranty or endorsement thereof. Use of such information may require a license from a third party under the patents or other intellectual property of the third party, or a license from TI under the patents or other intellectual property of TI.

Reproduction of significant portions of TI information in TI data books or data sheets is permissible only if reproduction is without alteration and is accompanied by all associated warranties, conditions, limitations, and notices. TI is not responsible or liable for such altered documentation. Information of third parties may be subject to additional restrictions.

Resale of TI components or services with statements different from or beyond the parameters stated by TI for that component or service voids all express and any implied warranties for the associated TI component or service and is an unfair and deceptive business practice. TI is not responsible or liable for any such statements.

Buyer acknowledges and agrees that it is solely responsible for compliance with all legal, regulatory and safety-related requirements concerning its products, and any use of TI components in its applications, notwithstanding any applications-related information or support that may be provided by TI. Buyer represents and agrees that it has all the necessary expertise to create and implement safeguards which anticipate dangerous consequences of failures, monitor failures and their consequences, lessen the likelihood of failures that might cause harm and take appropriate remedial actions. Buyer will fully indemnify TI and its representatives against any damages arising out of the use of any TI components in safety-critical applications.

In some cases, TI components may be promoted specifically to facilitate safety-related applications. With such components, TI's goal is to help enable customers to design and create their own end-product solutions that meet applicable functional safety standards and requirements. Nonetheless, such components are subject to these terms.

No TI components are authorized for use in FDA Class III (or similar life-critical medical equipment) unless authorized officers of the parties have executed a special agreement specifically governing such use.

Only those TI components which TI has specifically designated as military grade or "enhanced plastic" are designed and intended for use in military/aerospace applications or environments. Buyer acknowledges and agrees that any military or aerospace use of TI components which have **not** been so designated is solely at the Buyer's risk, and that Buyer is solely responsible for compliance with all legal and regulatory requirements in connection with such use.

TI has specifically designated certain components which meet ISO/TS16949 requirements, mainly for automotive use. Components which have not been so designated are neither designed nor intended for automotive use; and TI will not be responsible for any failure of such components to meet such requirements.

Products

Audio	www.ti.com/audio
Amplifiers	amplifier.ti.com
Data Converters	dataconverter.ti.com
DLP® Products	www.dlp.com
DSP	dsp.ti.com
Clocks and Timers	www.ti.com/clocks
Interface	interface.ti.com
Logic	logic.ti.com
Power Mgmt	power.ti.com
Microcontrollers	microcontroller.ti.com
RFID	www.ti-rfid.com
OMAP Mobile Processors	www.ti.com/omap
Wireless Connectivity	www.ti.com/wirelessconnectivity

Applications

Automotive and Transportation	www.ti.com/automotive
Communications and Telecom	www.ti.com/communications
Computers and Peripherals	www.ti.com/computers
Consumer Electronics	www.ti.com/consumer-apps
Energy and Lighting	www.ti.com/energy
Industrial	www.ti.com/industrial
Medical	www.ti.com/medical
Security	www.ti.com/security
Space, Avionics and Defense	www.ti.com/space-avionics-defense
Video and Imaging	www.ti.com/video

TI E2E Community e2e.ti.com