

SN54ALS114A, SN74ALS114A DUAL J-K NEGATIVE-EDGE-TRIGGERED FLIP-FLOPS WITH PRESET, COMMON CLEAR, AND COMMON CLOCK

SDAS201 - D2661, DECEMBER 1982 - REVISED MAY 1986

- Fully Buffered to Offer Maximum isolation from External Disturbance
- Package Options include Plastic Small Outline Packages, Ceramic Chip Carriers, and Standard Plastic and Ceramic 300-mil DIPs
- Typical Maximum Clock Frequency 30 MHz
- Typical Power Dissipation per Flip-Flop 6 mW
- Dependable Texas Instruments Quality and Reliability

description

These devices contain two independent J-K negative-edge-triggered flip-flops. A low level at the Preset or Clear inputs sets or resets the outputs regardless of the levels of the other inputs. When Preset and Clear are inactive (high), data at the J and K inputs meeting the setup time requirements are transferred to the outputs on the negative-going edge of the clock pulse. Clock triggering occurs at a voltage level and is not directly related to the fall time of the clock pulse. Following the hold time interval, data at the J and K inputs may be changed without affecting the levels at the outputs. These versatile flip-flops can perform as toggle flip-flops by tying J and K high.

The SN54ALS114A is characterized for operation over the full military temperature range of -55°C to 125°C . The SN74ALS114A is characterized for operation from 0°C to 70°C .

FUNCTION TABLE

INPUTS			OUTPUTS			
PRE	CLR	CLK	J	K	Q	\bar{Q}
L	H	X	X	X	H	L
H	L	X	X	X	L	H
L	L	X	X	X	H \dagger	H \dagger
H	H	\downarrow	L	L	Q_0	\bar{Q}_0
H	H	\downarrow	H	L	H	L
H	H	\downarrow	L	H	L	H
H	H	\downarrow	H	H	TOGGLE	
H	H	H	X	X	Q_0	\bar{Q}_0

\dagger The output levels in this configuration are not guaranteed to meet the minimum levels for V_{OH} if the lows at Preset and Clear are near V_{IL} maximum. Furthermore, this configuration is nonstable; that is, it will not persist when either Preset or Clear returns to its inactive (high) level.

SN54ALS114A . . . J PACKAGE
SN74ALS114A . . . D OR N PACKAGE
(TOP VIEW)

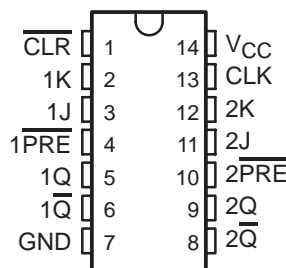

SN54ALS114A . . . FK PACKAGE
(TOP VIEW)

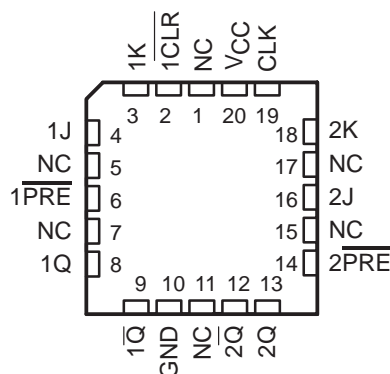

NC—No internal connection

logic symbol \ddagger

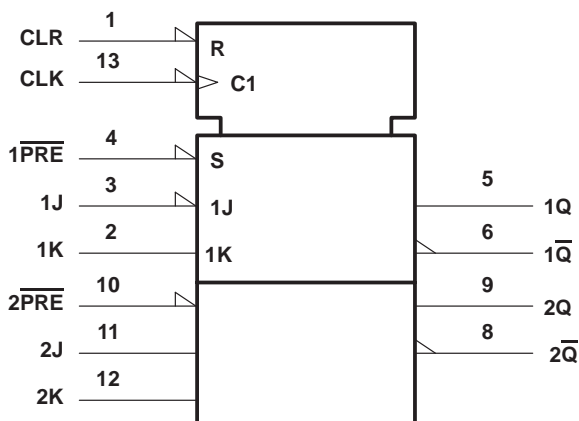

\ddagger This symbol is in accordance with ANSI/IEEE Std 911-1984 and IEC Publication 617-12.

Pin numbers are for D, J, and N packages.

PRODUCTION DATA information is current as of publication date. Products conform to specifications per the terms of Texas Instruments standard warranty. Production processing does not necessarily include testing of all parameters.

TEXAS
INSTRUMENTS

POST OFFICE BOX 655303 • DALLAS, TEXAS 75265
POST OFFICE BOX 1443 • HOUSTON, TEXAS 77001

Copyright © 1986, Texas Instruments Incorporated
5BASIC

SN54ALS114A, SN74ALS114A DUAL J-K NEGATIVE-EDGE-TRIGGERED FLIP-FLOPS WITH PRESET, COMMON CLEAR, AND COMMON CLOCK

SDAS201 - D2661, DECEMBER 1982 - REVISED MAY 1986

logic diagram (positive logic)

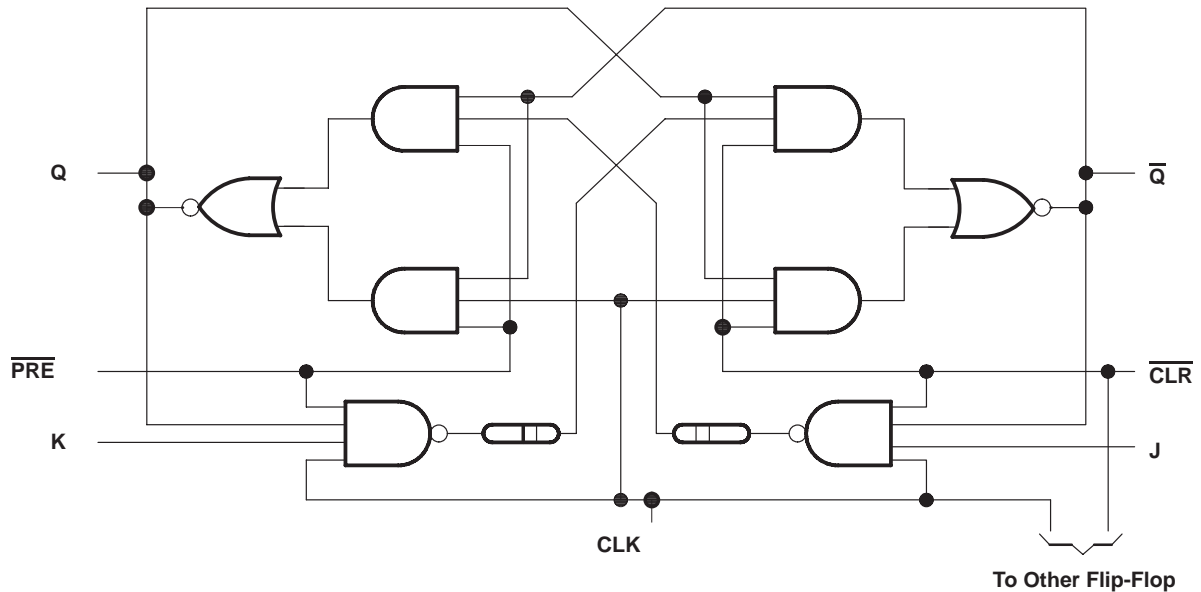

absolute maximum ratings over operating free-air temperature range (unless otherwise noted)

Supply voltage, V_{CC}	7 V
Input voltage	7 V
Operating free-air temperature range: SN54ALS114A	-55°C to 125°C
SN74ALS114A	0°C to 70°C
Storage temperature range	-65°C to 150°C

recommended operating conditions

	SN54ALS114A			SN74ALS114A			UNIT
	MIN	NOM	MAX	MIN	NOM	MAX	
V_{CC} Supply voltage	4.5	5	5.5	4.5	5	5.5	V
V_{IH} High-level input voltage	2			2			V
V_{IL} Low-level input voltage			0.7			0.8	V
I_{OH} High-level output current			-0.4			-0.4	mA
I_{OL} Low-level output current			4			8	mA
f_{clock} Clock frequency	0		25	0		30	mHz
t_w Pulse duration	PRE or CLR low		20	10		ns	
	CLK high		20	16.5			
	CLK low		20	16.5			
t_{su} Setup time before CLK↓	Data		25	22		ns	
	PRE or CLR inactive		25	20			
t_h Hold time, data after CLK↓	0			0		ns	
T_A Operating free-air temperature	-55		125	0		70	°C

SN54ALS114A, SN74ALS114A DUAL J-K NEGATIVE-EDGE-TRIGGERED FLIP-FLOPS WITH PRESET, COMMON CLEAR, AND COMMON CLOCK

SDAS201 – D2661, DECEMBER 1982 – REVISED MAY 1986

electrical characteristics over recommended operating free-air temperature range (unless otherwise noted)

PARAMETER	TEST CONDITIONS	SN54ALS114A		SN74ALS114A		UNIT	
		MIN	TYP†	MAX	MIN		TYP†
V _{IK}	V _{CC} = 4.5 V, I _I = -18 mA			-1.5		-1.5	V
V _{OH}	V _{CC} = 4.5 V to 5.5 V, I _{OH} = -0.4 mA	V _{CC} -2		V _{CC} -2			V
V _{OL}	V _{CC} = 4.5 V, I _{OL} = 4 mA	0.25 0.4					V
	V _{CC} = 4.5 V, I _{OL} = 8 mA			0.35 0.5			
I _I	J, K, or CLK PRE or CLR	V _{CC} = 5.5 V, V _I = 7 V	0.1		0.1		mA
			0.2		0.2		
I _{IH}	J, K, or CLK PRE or CLR	V _{CC} = 5.5 V, V _I = 2.7 V	20		20		μA
			40		40		
I _{IL}	J, K, or CLK PRE or CLR	V _{CC} = 5.5 V, V _I = 0.4 V	-0.2		-0.2		mA
			-0.4		-0.4		
I _O ‡	V _{CC} = 5.5 V, V _O = 2.25 V	-30	-112	-30	-112		mA
I _{CC}	V _{CC} = 5.5 V, See Note 1	2.5 4.5		2.5 4.5			mA

† All typical values are at V_{CC} = 5 V, T_A = 25°C.

‡ The output conditions have been chosen to produce a current that closely approximates one half of the true short-circuit output current, I_{OS}.

NOTE 1: I_{CC} is measured with J, K, CLK, and PRE grounded, then with J, K, CLK, and CLR grounded.

switching characteristics (see Note 2)

PARAMETER	FROM (INPUT)	TO (OUTPUT)	V _{CC} = 4.5 V to 5.5 V, C _L = 50 pF, R _L = 500 Ω, T _A = MIN to MAX				UNIT
			SN54ALS114A		SN74ALS114A		
			MIN	MAX	MIN	MAX	
f _{max}			25		30		MHz
t _{PLH}	PRE or CLR	Q or Q̄	3	29	3	15	ns
t _{PHL}			4	30	4	18	
t _{PLH}	CLK	Q or Q̄	3	28	3	15	ns
t _{PHL}			5	31	5	19	

NOTE 2: Load circuit and Voltage waveforms are shown in Section 1.



IMPORTANT NOTICE

Texas Instruments Incorporated and its subsidiaries (TI) reserve the right to make corrections, modifications, enhancements, improvements, and other changes to its products and services at any time and to discontinue any product or service without notice. Customers should obtain the latest relevant information before placing orders and should verify that such information is current and complete. All products are sold subject to TI's terms and conditions of sale supplied at the time of order acknowledgment.

TI warrants performance of its hardware products to the specifications applicable at the time of sale in accordance with TI's standard warranty. Testing and other quality control techniques are used to the extent TI deems necessary to support this warranty. Except where mandated by government requirements, testing of all parameters of each product is not necessarily performed.

TI assumes no liability for applications assistance or customer product design. Customers are responsible for their products and applications using TI components. To minimize the risks associated with customer products and applications, customers should provide adequate design and operating safeguards.

TI does not warrant or represent that any license, either express or implied, is granted under any TI patent right, copyright, mask work right, or other TI intellectual property right relating to any combination, machine, or process in which TI products or services are used. Information published by TI regarding third-party products or services does not constitute a license from TI to use such products or services or a warranty or endorsement thereof. Use of such information may require a license from a third party under the patents or other intellectual property of the third party, or a license from TI under the patents or other intellectual property of TI.

Reproduction of TI information in TI data books or data sheets is permissible only if reproduction is without alteration and is accompanied by all associated warranties, conditions, limitations, and notices. Reproduction of this information with alteration is an unfair and deceptive business practice. TI is not responsible or liable for such altered documentation. Information of third parties may be subject to additional restrictions.

Resale of TI products or services with statements different from or beyond the parameters stated by TI for that product or service voids all express and any implied warranties for the associated TI product or service and is an unfair and deceptive business practice. TI is not responsible or liable for any such statements.

TI products are not authorized for use in safety-critical applications (such as life support) where a failure of the TI product would reasonably be expected to cause severe personal injury or death, unless officers of the parties have executed an agreement specifically governing such use. Buyers represent that they have all necessary expertise in the safety and regulatory ramifications of their applications, and acknowledge and agree that they are solely responsible for all legal, regulatory and safety-related requirements concerning their products and any use of TI products in such safety-critical applications, notwithstanding any applications-related information or support that may be provided by TI. Further, Buyers must fully indemnify TI and its representatives against any damages arising out of the use of TI products in such safety-critical applications.

TI products are neither designed nor intended for use in military/aerospace applications or environments unless the TI products are specifically designated by TI as military-grade or "enhanced plastic." Only products designated by TI as military-grade meet military specifications. Buyers acknowledge and agree that any such use of TI products which TI has not designated as military-grade is solely at the Buyer's risk, and that they are solely responsible for compliance with all legal and regulatory requirements in connection with such use.

TI products are neither designed nor intended for use in automotive applications or environments unless the specific TI products are designated by TI as compliant with ISO/TS 16949 requirements. Buyers acknowledge and agree that, if they use any non-designated products in automotive applications, TI will not be responsible for any failure to meet such requirements.

Following are URLs where you can obtain information on other Texas Instruments products and application solutions:

Products

Amplifiers	amplifier.ti.com
Data Converters	dataconverter.ti.com
DSP	dsp.ti.com
Clocks and Timers	www.ti.com/clocks
Interface	interface.ti.com
Logic	logic.ti.com
Power Mgmt	power.ti.com
Microcontrollers	microcontroller.ti.com
RFID	www.ti-rfid.com
RF/IF and ZigBee® Solutions	www.ti.com/lprf

Applications

Audio	www.ti.com/audio
Automotive	www.ti.com/automotive
Broadband	www.ti.com/broadband
Digital Control	www.ti.com/digitalcontrol
Medical	www.ti.com/medical
Military	www.ti.com/military
Optical Networking	www.ti.com/opticalnetwork
Security	www.ti.com/security
Telephony	www.ti.com/telephony
Video & Imaging	www.ti.com/video
Wireless	www.ti.com/wireless

Mailing Address: Texas Instruments, Post Office Box 655303, Dallas, Texas 75265
Copyright © 2008, Texas Instruments Incorporated