

SN54283, SN54LS283, SN54S283, SN74283, SN74LS283, SN74S283 4-BIT BINARY FULL ADDERS WITH FAST CARRY

SDLS095A - OCTOBER 1976 - REVISED MARCH 1988

logic symbol†

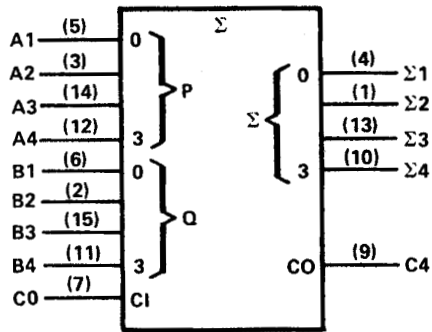

†This symbol is in accordance with ANSI/IEEE Std. 91-1984 and IEC Publication 617-12.

Pin numbers shown are for D, J, N, and W packages.

logic diagram (positive logic)

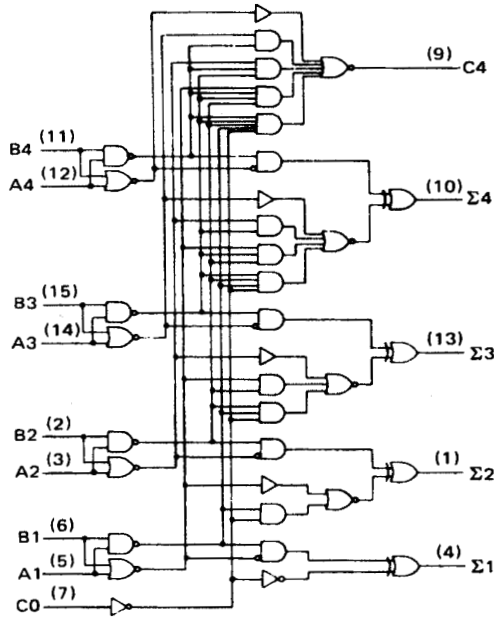

Pin numbers shown are for D, J, N, and W packages.

schematics of inputs and outputs '283

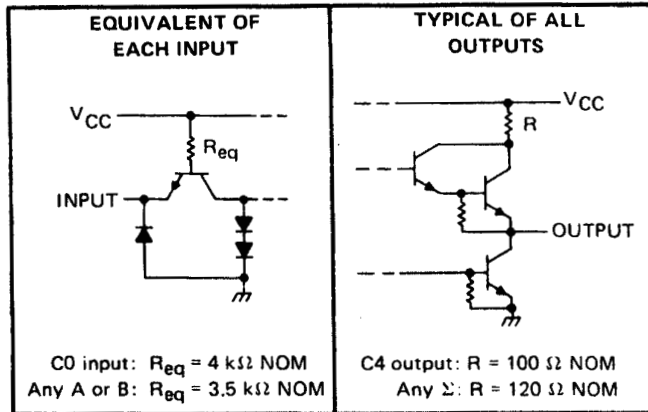

'LS283

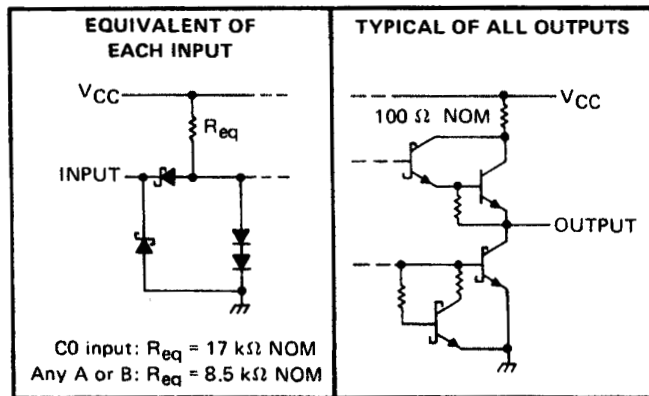

'S283

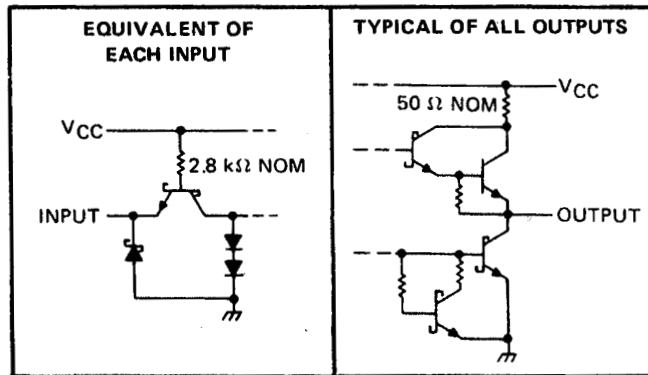

absolute maximum ratings over operating free-air temperature (unless otherwise noted)

Supply voltage, V_{CC} (see Note 1)	7V
Input voltage: '283, 'S283	5.5V
'LS283	7V
Interemitter voltage (see Note 2)	5.5V
Operating free-air temperature range: SN54283, SN54LS283, SN54S283	-55°C to 125°C
SN74283, SN74LS283, SN74S283	0°C to 70°C
Storage temperature range	-65°C to 150°C

NOTES: 1. Voltage values, except interemitter voltage, are with respect to network ground terminal.

2. This is the voltage between two emitters of a multiple-emitter transistor. This rating applies for the '283 and 'S283 only between the following pairs: A1 and B1, A2 and B2, A3 and B3, A4 and B4.

SN54283, SN74283

4-BIT BINARY FULL ADDERS WITH FAST CARRY

SDLS095A - OCTOBER 1976 - REVISED MARCH 1988

recommended operating conditions

		SN54283			SN74283			UNIT
		MIN	NOM	MAX	MIN	NOM	MAX	
Supply Voltage, V_{CC}		4.5	5	5.5	4.75	5	5.25	V
High-level output current, I_{OH}	Any output except C4	-800			-800			μ A
	Output C4	-400			-400			
Low-level output current, I_{OL}	Any output except C4	16			16			mA
	Output C4	8			8			
Operating free-air temperature, T_A		-55	125		0	70		$^{\circ}$ C

electrical characteristics over recommended operating free-air temperature range (unless otherwise noted)

PARAMETER		TEST CONDITIONS [†]	SN54283			SN74283			UNIT	
			MIN	TYP [‡]	MAX	MIN	TYP [‡]	MAX		
V_{IH}	High-level input voltage		2			2			V	
V_{IL}	Low-level input voltage		0.8			0.8			V	
V_{IK}	Input clamp voltage	$V_{CC} = \text{MIN}, I_I = -12 \text{ mA}$	-1.5			-1.5			V	
V_{OH}	High-level output voltage	$V_{CC} = \text{MIN}, V_{IH} = 2 \text{ V}, V_{IL} = 0.8 \text{ V}, I_{OH} = \text{MAX}$	2.4	3.6		2.4	3.6		V	
V_{OL}	Low-level output voltage	$V_{CC} = \text{MIN}, V_{IH} = 2 \text{ V}, V_{IL} = 0.8 \text{ V}, I_{OL} = \text{MAX}$		0.2	0.4		0.2	0.4	V	
I_I	Input current at maximum input voltage	$V_{CC} = \text{MAX}, V_I = 5.5 \text{ V}$	1			1			mA	
I_{IH}	High-level input current	$V_{CC} = \text{MAX}, V_I = 2.4 \text{ V}$	40			40			μ A	
I_{IL}	Low-level input current	$V_{CC} = \text{MAX}, V_I = 0.4 \text{ V}$	-1.6			-1.6			mA	
I_{OS}	Short-circuit output current \S	Any output except C4	$V_{CC} = \text{MAX}$			-20	-55	-18	-55	mA
		Output C4	$V_{CC} = \text{MAX}$			-20	-70	-18	-70	
I_{CC}	Supply current	$V_{CC} = \text{MAX},$ Outputs open	All B low, other inputs at 4.5 V		56		56		mA	
			All inputs at 4.5 V		66	99	66	110		

[†] For conditions shown as MIN or MAX, use the appropriate value specified under recommended operating conditions.

[‡] All typical values are at $V_{CC} = 5 \text{ V}, T_A = 25^{\circ}\text{C}$.

\S Only one output should be shorted at a time.

switching characteristics, $V_{CC} = 5 \text{ V}, T_A = 25^{\circ}\text{C}$

PARAMETER [¶]	FROM (INPUT)	TO (OUTPUT)	TEST CONDITIONS	MIN	TYP	MAX	UNIT
t_{PLH}	C0	Any Σ	$C_L = 15 \text{ pF}, R_L = 400 \Omega,$ See Note 3	14	21	ns	
t_{PHL}				12	21		
t_{PLH}	A_i or B_i	Σ_i		16	24	ns	
t_{PHL}				16	24		
t_{PLH}	C0	C4	$C_L = 15 \text{ pF}, R_L = 780 \Omega,$ See Note 3	9	14	ns	
t_{PHL}				11	16		
t_{PLH}	A_i or B_i	C4		9	14	ns	
t_{PHL}				11	16		

[¶] t_{PLH} = propagation delay time, low-to-high-level output

t_{PHL} = propagation delay time, high-to-low-level output

NOTE 3: Load circuits and voltage waveforms are shown in Section 1.



SN54LS283, SN74LS283

4-BIT BINARY FULL ADDERS WITH FAST CARRY

SDLS095A - OCTOBER 1976 - REVISED MARCH 1988

recommended operating conditions

	SN54LS283			SN74LS283			UNIT
	MIN	NOM	MAX	MIN	NOM	MAX	
Supply voltage, V_{CC}	4.5	5	5.5	4.75	5	5.25	V
High-level output current, I_{OH}			-400			-400	μ A
Low-level output current, I_{OL}			4			8	mA
Operating free-air temperature, T_A	-55		125	0		70	$^{\circ}$ C

electrical characteristics over recommended operating free-air temperature range (unless otherwise noted)

PARAMETER		TEST CONDITIONS [†]	SN54LS283			SN74LS283			UNIT		
			MIN	TYP [‡]	MAX	MIN	TYP [‡]	MAX			
V_{IH}	High-level input voltage		2			2			V		
V_{IL}	Low-level input voltage				0.7			0.8	V		
V_{IK}	Input clamp voltage	$V_{CC} = \text{MIN}, I_I = -18 \text{ mA}$			-1.5			-1.5	V		
V_{OH}	High-level output voltage	$V_{CC} = \text{MIN}, V_{IH} = 2 \text{ V}, V_{IL} = V_{IL \text{ max}}, I_{OH} = -400 \mu\text{A}$	2.5	3.4		2.7	3.4		V		
V_{OL}	Low-level output voltage	$V_{CC} = \text{MIN}, V_{IH} = 2 \text{ V}, V_{IL} = V_{IL \text{ max}}$	$I_{OL} = 4 \text{ mA}$		0.25	0.4	$I_{OL} = 4 \text{ mA}$		0.25	0.4	V
			$I_{OL} = 8 \text{ mA}$				$I_{OL} = 8 \text{ mA}$		0.35	0.5	
I_I	Input current at maximum input voltage	Any A or B	$V_{CC} = \text{MAX}, V_I = 7 \text{ V}$		0.2		0.2		mA		
		C0									
I_{IH}	High-level input current	Any A or B	$V_{CC} = \text{MAX}, V_I = 2.7 \text{ V}$		40		40		μ A		
		C0									
I_{IL}	Low-level input current	Any A or B	$V_{CC} = \text{MAX}, V_I = 0.4 \text{ V}$		-0.8		-0.8		mA		
		C0									
I_{OS}	Short-circuit output current [§]	$V_{CC} = \text{MAX}$	-20	-100	-20	-100			mA		
I_{CC}	Supply current	$V_{CC} = \text{MAX},$ Outputs open	All inputs grounded		22	39	22		39		mA
			All B low, other inputs at 4.5 V		19	34	19		34		
			All inputs at 4.5 V		19	34	19		34		

[†]For conditions shown as MIN or MAX, use the appropriate value specified under recommended operating conditions.

[‡]All typical values are at $V_{CC} = 5 \text{ V}, T_A = 25^{\circ} \text{C}$.

[§]Only one output should be shorted at a time and duration of the short-circuit should not exceed one second.

switching characteristics, $V_{CC} = 5 \text{ V}, T_A = 25^{\circ} \text{C}$

PARAMETER [¶]	FROM (INPUT)	TO (OUTPUT)	TEST CONDITIONS		MIN	TYP	MAX	UNIT
t_{PLH}	C0	Any Σ	$C_L = 15 \text{ pF},$ See Note 3	$R_L = 2 \text{ k}\Omega,$	16	24	ns	
t_{PHL}					15	24		
t_{PLH}	A_i or B_i	Σ_j			15	24	ns	
t_{PHL}					15	24		
t_{PLH}	C0	C4			11	17	ns	
t_{PHL}					11	22		
t_{PLH}	A_i or B_i	C4			11	17	ns	
t_{PHL}					12	17		

[¶] t_{PLH} = propagation delay time, low-to-high-level output

t_{PHL} = propagation delay time, high-to-low-level output

NOTE 3: Load circuits and voltage waveforms are shown in Section 1.



SN54S283, SN74S283 4-BIT BINARY FULL ADDERS WITH FAST CARRY

SDLS095A - OCTOBER 1976 - REVISED MARCH 1988

recommended operating conditions

		SN54S283			SN74S283			UNIT	
		MIN	NOM	MAX	MIN	NOM	MAX		
Supply voltage, V_{CC}		4.5	5	5.5	4.75	5	5.25	V	
High-level output current, I_{OH}	Any output except C4	-1			-1			mA	
	Output C4	-500			-500			μ A	
Low-level output current, I_{OL}	Any output except C4	20			20			mA	
	Output C4	10			10				
Operating free-air temperature, T_A		-55			0			70	$^{\circ}$ C

electrical characteristics over recommended operating free-air temperature range (unless otherwise noted)

PARAMETER		TEST CONDITIONS [†]	MIN	TYP [‡]	MAX	UNIT	
V_{IH}	High-level input voltage		2			V	
V_{IL}	Low-level input voltage				0.8	V	
V_{IK}	Input clamp voltage	$V_{CC} = \text{MIN}$, $I_I = -18 \text{ mA}$			-1.2	V	
V_{OH}	High-level output voltage	SN54S283 $V_{CC} = \text{MIN}$, $V_{IH} = 2 \text{ V}$,	2.5	3.4		V	
		SN74S283 $V_{IL} = 0.8 \text{ V}$, $I_{OH} = \text{MAX}$	2.7	3.4			
V_{OL}	Low-level output voltage	$V_{CC} = \text{MIN}$, $V_{IH} = 2 \text{ V}$, $V_{IL} = 0.8 \text{ V}$, $I_{OL} = \text{MAX}$			0.5	V	
I_I	Input current at maximum input voltage	$V_{CC} = \text{MAX}$, $V_I = 5.5 \text{ V}$			1	mA	
I_{IH}	High-level input current	$V_{CC} = \text{MAX}$, $V_I = 2.7 \text{ V}$			50	μ A	
I_{IL}	Low-level input current	$V_{CC} = \text{MAX}$, $V_I = 0.5 \text{ V}$			-2	mA	
I_{OS}	Short-circuit output current [§]	Any output except C4 Output C4	$V_{CC} = \text{MAX}$		-40	-100	mA
					-20	-100	
I_{CC}	Supply current	$V_{CC} = \text{MAX}$, Outputs open	All B low, other inputs at 4.5 V	80		mA	
			All inputs at 4.5 V	95	160		

[†]For conditions shown as MIN or MAX, use the appropriate value specified under recommended operating conditions for the applicable device type.

[‡]All typical values are at $V_{CC} = 5 \text{ V}$, $T_A = 25^{\circ}\text{C}$.

[§]Only one output should be shorted at a time, and duration of the short-circuit should not exceed one second.

switching characteristics, $V_{CC} = 5 \text{ V}$, $T_A = 25^{\circ}\text{C}$

PARAMETER [†]	FROM (INPUT)	TO (OUTPUT)	TEST CONDITIONS	MIN	TYP	MAX	UNIT
t_{PLH}	C0	Any Σ	$C_L = 15 \text{ pF}$, $R_L = 280 \Omega$, See Note 3		11	18	ns
t_{PHL}					12	18	
t_{PLH}	A_i or B_i	Σ_i			12	18	ns
t_{PHL}					11.5	18	
t_{PLH}	C0	C4	$C_L = 15 \text{ pF}$, $R_L = 560 \Omega$, See Note 3		6	11	ns
t_{PHL}					7.5	11	
t_{PLH}	A_i or B_i	C4			7.5	12	ns
t_{PHL}					8.5	12	

[†] t_{PLH} = propagation delay time, low-to-high-level output

t_{PHL} = propagation delay time, high-to-low-level output

NOTE 3: Load circuits and voltage waveforms are shown in Section 1.



PACKAGING INFORMATION

Orderable Device	Status ⁽¹⁾	Package Type	Package Drawing	Pins	Package Qty	Eco Plan ⁽²⁾	Lead/ Ball Finish	MSL Peak Temp ⁽³⁾	Samples (Requires Login)
5962-7604301VEA	ACTIVE	CDIP	J	16	25	TBD	A42	N / A for Pkg Type	
76043012A	ACTIVE	LCCC	FK	20	1	TBD	Call TI	Call TI	
7604301EA	ACTIVE	CDIP	J	16	1	TBD	Call TI	Call TI	
7604301FA	ACTIVE	CFP	W	16	1	TBD	Call TI	Call TI	
JM38510/31202B2A	ACTIVE	LCCC	FK	20	1	TBD	POST-PLATE	N / A for Pkg Type	
JM38510/31202BEA	ACTIVE	CDIP	J	16	1	TBD	A42	N / A for Pkg Type	
JM38510/31202BFA	ACTIVE	CFP	W	16	1	TBD	A42	N / A for Pkg Type	
M38510/31202B2A	ACTIVE	LCCC	FK	20	1	TBD	POST-PLATE	N / A for Pkg Type	
M38510/31202BEA	ACTIVE	CDIP	J	16	1	TBD	A42	N / A for Pkg Type	
M38510/31202BFA	ACTIVE	CFP	W	16	1	TBD	A42	N / A for Pkg Type	
SN54LS283J	ACTIVE	CDIP	J	16	1	TBD	A42	N / A for Pkg Type	
SN54S283J	ACTIVE	CDIP	J	16	1	TBD	A42	N / A for Pkg Type	
SN74283N	OBSOLETE	PDIP	N	16		TBD	Call TI	Call TI	
SN74LS283D	ACTIVE	SOIC	D	16	40	Green (RoHS & no Sb/Br)	CU NIPDAU	Level-1-260C-UNLIM	
SN74LS283DE4	ACTIVE	SOIC	D	16	40	Green (RoHS & no Sb/Br)	CU NIPDAU	Level-1-260C-UNLIM	
SN74LS283DG4	ACTIVE	SOIC	D	16	40	Green (RoHS & no Sb/Br)	CU NIPDAU	Level-1-260C-UNLIM	
SN74LS283N	ACTIVE	PDIP	N	16	25	Pb-Free (RoHS)	CU NIPDAU	N / A for Pkg Type	
SN74LS283N3	OBSOLETE	PDIP	N	16		TBD	Call TI	Call TI	
SN74LS283NE4	ACTIVE	PDIP	N	16	25	Pb-Free (RoHS)	CU NIPDAU	N / A for Pkg Type	
SN74LS283NSR	ACTIVE	SO	NS	16	2000	Green (RoHS & no Sb/Br)	CU NIPDAU	Level-1-260C-UNLIM	
SN74LS283NSRE4	ACTIVE	SO	NS	16	2000	Green (RoHS & no Sb/Br)	CU NIPDAU	Level-1-260C-UNLIM	
SN74LS283NSRG4	ACTIVE	SO	NS	16	2000	Green (RoHS & no Sb/Br)	CU NIPDAU	Level-1-260C-UNLIM	
SN74S283D	OBSOLETE	SOIC	D	16		TBD	Call TI	Call TI	
SN74S283N	ACTIVE	PDIP	N	16	25	Pb-Free (RoHS)	CU NIPDAU	N / A for Pkg Type	
SN74S283N3	OBSOLETE	PDIP	N	16		TBD	Call TI	Call TI	

Orderable Device	Status ⁽¹⁾	Package Type	Package Drawing	Pins	Package Qty	Eco Plan ⁽²⁾	Lead/ Ball Finish	MSL Peak Temp ⁽³⁾	Samples (Requires Login)
SN74S283NE4	ACTIVE	PDIP	N	16	25	Pb-Free (RoHS)	CU NIPDAU	N / A for Pkg Type	
SNJ54LS283FK	ACTIVE	LCCC	FK	20	1	TBD	POST-PLATE	N / A for Pkg Type	
SNJ54LS283J	ACTIVE	CDIP	J	16	1	TBD	A42	N / A for Pkg Type	
SNJ54LS283W	ACTIVE	CFP	W	16	1	TBD	A42	N / A for Pkg Type	
SNJ54S283FK	ACTIVE	LCCC	FK	20	1	TBD	POST-PLATE	N / A for Pkg Type	
SNJ54S283J	ACTIVE	CDIP	J	16	1	TBD	A42	N / A for Pkg Type	
SNJ54S283W	ACTIVE	CFP	W	16	1	TBD	A42	N / A for Pkg Type	

⁽¹⁾ The marketing status values are defined as follows:

ACTIVE: Product device recommended for new designs.

LIFEBUY: TI has announced that the device will be discontinued, and a lifetime-buy period is in effect.

NRND: Not recommended for new designs. Device is in production to support existing customers, but TI does not recommend using this part in a new design.

PREVIEW: Device has been announced but is not in production. Samples may or may not be available.

OBSELETE: TI has discontinued the production of the device.

⁽²⁾ Eco Plan - The planned eco-friendly classification: Pb-Free (RoHS), Pb-Free (RoHS Exempt), or Green (RoHS & no Sb/Br) - please check <http://www.ti.com/productcontent> for the latest availability information and additional product content details.

TBD: The Pb-Free/Green conversion plan has not been defined.

Pb-Free (RoHS): TI's terms "Lead-Free" or "Pb-Free" mean semiconductor products that are compatible with the current RoHS requirements for all 6 substances, including the requirement that lead not exceed 0.1% by weight in homogeneous materials. Where designed to be soldered at high temperatures, TI Pb-Free products are suitable for use in specified lead-free processes.

Pb-Free (RoHS Exempt): This component has a RoHS exemption for either 1) lead-based flip-chip solder bumps used between the die and package, or 2) lead-based die adhesive used between the die and leadframe. The component is otherwise considered Pb-Free (RoHS compatible) as defined above.

Green (RoHS & no Sb/Br): TI defines "Green" to mean Pb-Free (RoHS compatible), and free of Bromine (Br) and Antimony (Sb) based flame retardants (Br or Sb do not exceed 0.1% by weight in homogeneous material)

⁽³⁾ MSL, Peak Temp. -- The Moisture Sensitivity Level rating according to the JEDEC industry standard classifications, and peak solder temperature.

Important Information and Disclaimer: The information provided on this page represents TI's knowledge and belief as of the date that it is provided. TI bases its knowledge and belief on information provided by third parties, and makes no representation or warranty as to the accuracy of such information. Efforts are underway to better integrate information from third parties. TI has taken and continues to take reasonable steps to provide representative and accurate information but may not have conducted destructive testing or chemical analysis on incoming materials and chemicals. TI and TI suppliers consider certain information to be proprietary, and thus CAS numbers and other limited information may not be available for release.

In no event shall TI's liability arising out of such information exceed the total purchase price of the TI part(s) at issue in this document sold by TI to Customer on an annual basis.

OTHER QUALIFIED VERSIONS OF SN54283, SN54LS283, SN54LS283-SP, SN54S283, SN74283, SN74LS283, SN74S283 :

● Catalog: [SN74283](#), [SN74LS283](#), [SN54LS283](#), [SN74S283](#)

- Military: [SN54283](#), [SN54LS283](#), [SN54S283](#)

- Space: [SN54LS283-SP](#)

NOTE: Qualified Version Definitions:

- Catalog - TI's standard catalog product
- Military - QML certified for Military and Defense Applications
- Space - Radiation tolerant, ceramic packaging and qualified for use in Space-based application

TAPE AND REEL INFORMATION

REEL DIMENSIONS

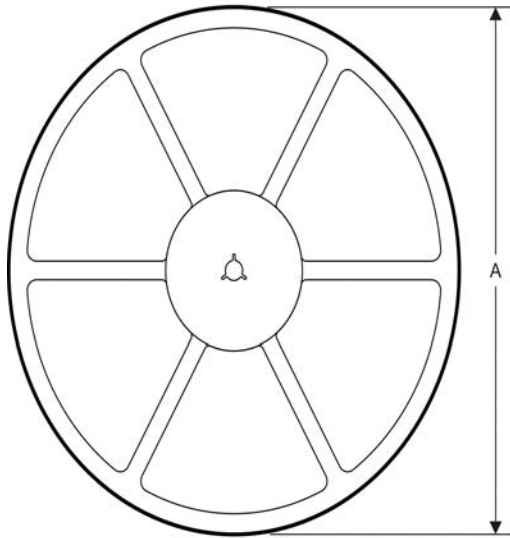

TAPE DIMENSIONS

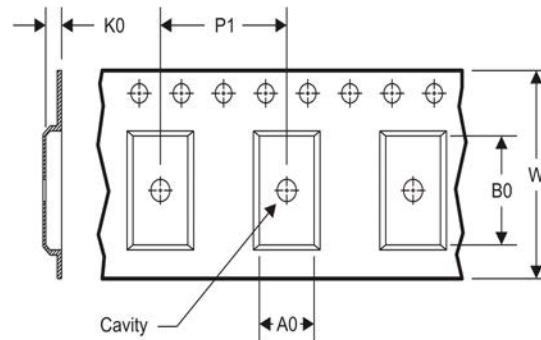

A0	Dimension designed to accommodate the component width
B0	Dimension designed to accommodate the component length
K0	Dimension designed to accommodate the component thickness
W	Overall width of the carrier tape
P1	Pitch between successive cavity centers

TAPE AND REEL INFORMATION

*All dimensions are nominal

Device	Package Type	Package Drawing	Pins	SPQ	Reel Diameter (mm)	Reel Width W1 (mm)	A0 (mm)	B0 (mm)	K0 (mm)	P1 (mm)	W (mm)	Pin1 Quadrant
SN74LS283NSR	SO	NS	16	2000	330.0	16.4	8.2	10.5	2.5	12.0	16.0	Q1

TAPE AND REEL BOX DIMENSIONS

*All dimensions are nominal

Device	Package Type	Package Drawing	Pins	SPQ	Length (mm)	Width (mm)	Height (mm)
SN74LS283NSR	SO	NS	16	2000	367.0	367.0	38.0

IMPORTANT NOTICE

Texas Instruments Incorporated and its subsidiaries (TI) reserve the right to make corrections, enhancements, improvements and other changes to its semiconductor products and services per JESD46C and to discontinue any product or service per JESD48B. Buyers should obtain the latest relevant information before placing orders and should verify that such information is current and complete. All semiconductor products (also referred to herein as "components") are sold subject to TI's terms and conditions of sale supplied at the time of order acknowledgment.

TI warrants performance of its components to the specifications applicable at the time of sale, in accordance with the warranty in TI's terms and conditions of sale of semiconductor products. Testing and other quality control techniques are used to the extent TI deems necessary to support this warranty. Except where mandated by applicable law, testing of all parameters of each component is not necessarily performed.

TI assumes no liability for applications assistance or the design of Buyers' products. Buyers are responsible for their products and applications using TI components. To minimize the risks associated with Buyers' products and applications, Buyers should provide adequate design and operating safeguards.

TI does not warrant or represent that any license, either express or implied, is granted under any patent right, copyright, mask work right, or other intellectual property right relating to any combination, machine, or process in which TI components or services are used. Information published by TI regarding third-party products or services does not constitute a license to use such products or services or a warranty or endorsement thereof. Use of such information may require a license from a third party under the patents or other intellectual property of the third party, or a license from TI under the patents or other intellectual property of TI.

Reproduction of significant portions of TI information in TI data books or data sheets is permissible only if reproduction is without alteration and is accompanied by all associated warranties, conditions, limitations, and notices. TI is not responsible or liable for such altered documentation. Information of third parties may be subject to additional restrictions.

Resale of TI components or services with statements different from or beyond the parameters stated by TI for that component or service voids all express and any implied warranties for the associated TI component or service and is an unfair and deceptive business practice. TI is not responsible or liable for any such statements.

Buyer acknowledges and agrees that it is solely responsible for compliance with all legal, regulatory and safety-related requirements concerning its products, and any use of TI components in its applications, notwithstanding any applications-related information or support that may be provided by TI. Buyer represents and agrees that it has all the necessary expertise to create and implement safeguards which anticipate dangerous consequences of failures, monitor failures and their consequences, lessen the likelihood of failures that might cause harm and take appropriate remedial actions. Buyer will fully indemnify TI and its representatives against any damages arising out of the use of any TI components in safety-critical applications.

In some cases, TI components may be promoted specifically to facilitate safety-related applications. With such components, TI's goal is to help enable customers to design and create their own end-product solutions that meet applicable functional safety standards and requirements. Nonetheless, such components are subject to these terms.

No TI components are authorized for use in FDA Class III (or similar life-critical medical equipment) unless authorized officers of the parties have executed a special agreement specifically governing such use.

Only those TI components which TI has specifically designated as military grade or "enhanced plastic" are designed and intended for use in military/aerospace applications or environments. Buyer acknowledges and agrees that any military or aerospace use of TI components which have **not** been so designated is solely at the Buyer's risk, and that Buyer is solely responsible for compliance with all legal and regulatory requirements in connection with such use.

TI has specifically designated certain components which meet ISO/TS16949 requirements, mainly for automotive use. Components which have not been so designated are neither designed nor intended for automotive use; and TI will not be responsible for any failure of such components to meet such requirements.

Products

Audio	www.ti.com/audio
Amplifiers	amplifier.ti.com
Data Converters	dataconverter.ti.com
DLP® Products	www.dlp.com
DSP	dsp.ti.com
Clocks and Timers	www.ti.com/clocks
Interface	interface.ti.com
Logic	logic.ti.com
Power Mgmt	power.ti.com
Microcontrollers	microcontroller.ti.com
RFID	www.ti-rfid.com
OMAP Mobile Processors	www.ti.com/omap
Wireless Connectivity	www.ti.com/wirelessconnectivity

Applications

Automotive and Transportation	www.ti.com/automotive
Communications and Telecom	www.ti.com/communications
Computers and Peripherals	www.ti.com/computers
Consumer Electronics	www.ti.com/consumer-apps
Energy and Lighting	www.ti.com/energy
Industrial	www.ti.com/industrial
Medical	www.ti.com/medical
Security	www.ti.com/security
Space, Avionics and Defense	www.ti.com/space-avionics-defense
Video and Imaging	www.ti.com/video

TI E2E Community e2e.ti.com