

SC87C51 CMOS Single-Chip 8-Bit EPROM Microcontroller

Product Specification

Microprocessor Division

DESCRIPTION

The Signetics SC87C51 is a high-performance microcontroller fabricated with Signetics high-density CMOS technology. The CMOS SC87C51 is functionally compatible with the NMOS SCN8031/SCN8051 and SC80C51 microcontrollers. The Signetics CMOS technology combines the high speed and density characteristics of HMOS with the low power attributes of CMOS. Signetics' epitaxial substrate minimizes latch-up sensitivity.

The SC87C51 contains a 4K x 8 EPROM, a 128 x 8 RAM, 32 I/O lines, two 16-bit counter/timers, a five-source, two priority level nested interrupt structure, a serial I/O port for either multi-processor communications, I/O expansion or full duplex UART, and on-chip oscillator and clock circuits.

In addition, the SC87C51 has two software selectable modes of power reduction - idle mode and power-down mode. The idle mode freezes the CPU while allowing the RAM, timers, serial port, and interrupt system to continue functioning. The power-down mode saves the RAM contents but freezes the oscillator, causing all other chip functions to be inoperative.

FEATURES

- **SCN8031/SCN8051/SC80C51 compatible**
 - 4K x 8 EPROM
 - 128 x 8 RAM
 - Two 16-bit counter/timers
 - Full duplex serial channel
 - Boolean processor
- **Memory addressing capability**
 - 64K ROM and 64K RAM
- **Power control modes:**
 - Idle mode
 - Power-down mode
- **CMOS and TTL compatible**
- **Three speed ranges at Vcc = 5V ±10%**
 - 3.5 to 12MHz
 - 3.5 to 16MHz
 - 0.5 to 12MHz
- **Four package styles**
- **Extended temperature ranges**
- **OTP package available**

LOGIC SYMBOL

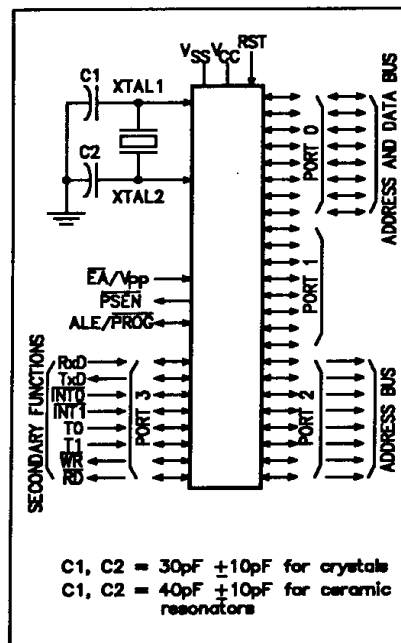

PIN CONFIGURATION

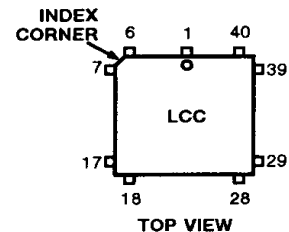
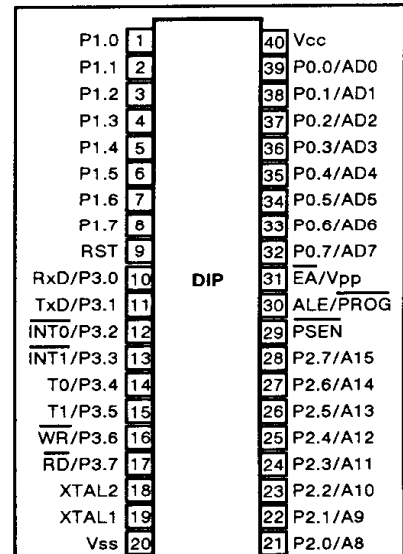

Pin	Function	Pin	Function
1	NC	23	NC
2	P1.0	24	P2.0/A8
3	P1.1	25	P2.1/A9
4	P1.2	26	P2.2/A10
5	P1.3	27	P2.3/A11
6	P1.4	28	P2.4/A12
7	P1.5	29	P2.5/A13
8	P1.6	30	P2.6/A14
9	P1.7	31	P2.7/A15
10	RST	32	PSEN
11	RxD/P3.0	33	ALE/PROG
12	NC	34	NC
13	TxD/P3.1	35	EA/Vpp
14	INT0/P3.2	36	P0.7/AD7
15	INT1/P3.3	37	P0.6/AD6
16	T0/P3.4	38	P0.5/AD5
17	T1/P3.5	39	P0.4/AD4
18	WR/P3.6	40	P0.3/AD3
19	RD/P3.7	41	P0.2/AD2
20	XTAL2	42	P0.1/AD1
21	XTAL1	43	P0.0/AD0
22	Vss	44	Vcc

CMOS Single-Chip 8-Bit EPROM Microcontroller

SC87C51

ORDERING INFORMATION

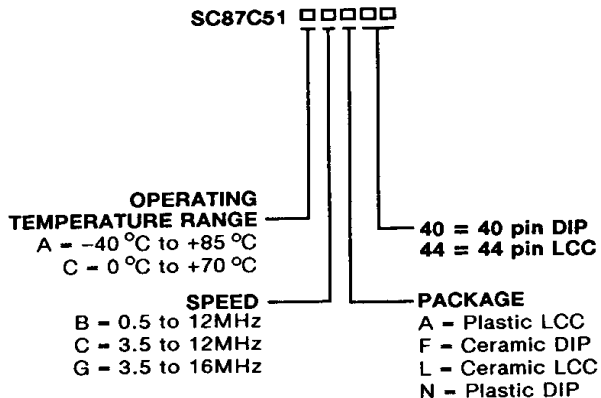

PART NUMBER SELECTION		
Part Number	Speed	Temperature and Package
SC87C51CCF40	3.5 to 12MHz	0 to +70°C, ceramic DIP
SC87C51CGF40	3.5 to 16MHz	0 to +70°C, ceramic DIP
SC87C51CBF40	0.5 to 12MHz	0 to +70°C, ceramic DIP*
SC87C51CCL44	3.5 to 12MHz	0 to +70°C, ceramic LCC
SC87C51CGL44	3.5 to 16MHz	0 to +70°C, ceramic LCC
SC87C51CBL44	0.5 to 12MHz	0 to +70°C, ceramic LCC*
SC87C51CCN40	3.5 to 12MHz	0 to +70°C, plastic DIP
SC87C51CGN40	3.5 to 16MHz	0 to +70°C, plastic DIP
SC87C51CBN40	0.5 to 12MHz	0 to +70°C, plastic DIP*
SC87C51CCA44	3.5 to 12MHz	0 to +70°C, plastic LCC
SC87C51CGA44	3.5 to 16MHz	0 to +70°C, plastic LCC
SC87C51CBA44	0.5 to 12MHz	0 to +70°C, plastic LCC*
SC87C51ACN40	3.5 to 12MHz	-40 to +85°C, plastic DIP
SC87C51AGN40	3.5 to 16MHz	-40 to +85°C, plastic DIP
SC87C51ACA44	3.5 to 12MHz	-40 to +85°C, plastic LCC
SC87C51AGA44	3.5 to 16MHz	-40 to +85°C, plastic LCC
SC87C51ABN40	0.5 to 12MHz	-40 to +85°C, plastic DIP*
SC87C51ABA44	0.5 to 12MHz	-40 to +85°C, plastic LCC*
SC87C51ACF40	3.5 to 12MHz	-40 to +85°C, ceramic DIP
SC87C51ACL44	3.5 to 12MHz	-40 to +85°C, ceramic LCC
SC87C51ABL44	0.5 to 12MHz	-40 to +85°C, ceramic LCC*
SC87C51AGL44	3.5 to 16MHz	-40 to +85°C, ceramic LCC
SC87C51AGF40	3.5 to 16MHz	-40 to +85°C, ceramic DIP
SC87C51ABF40	0.5 to 12MHz	-40 to +85°C, ceramic DIP*

*Contact Factory

BLOCK DIAGRAM

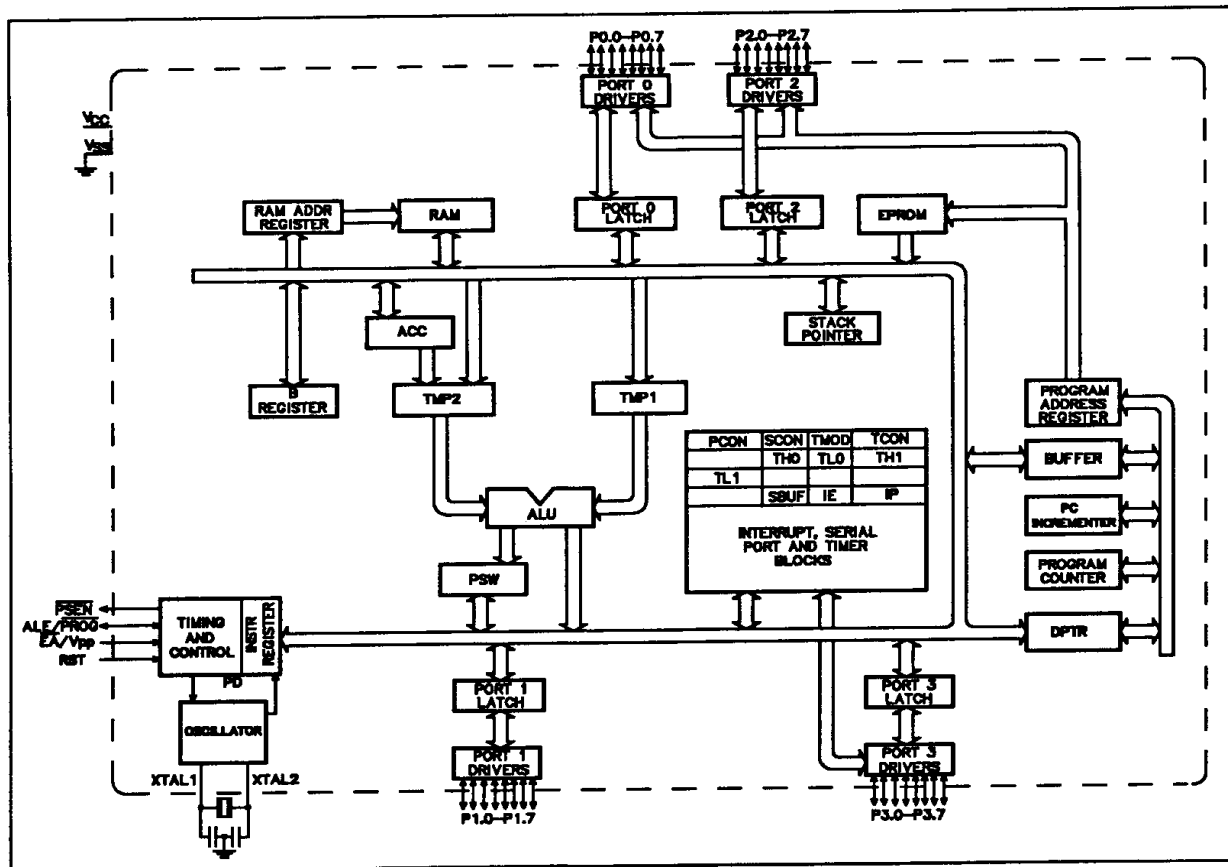

CMOS Single-Chip 8-Bit EPROM Microcontroller

SC87C51

PIN DESCRIPTION

MNEMONIC	PIN NO.		TYPE	NAME AND FUNCTION
	DIP	LCC		
V _{SS}	20	22	I	Ground: 0V reference.
V _{CC}	40	44	I	Power Supply: This is the power supply voltage for normal, idle, and power-down operation.
P0.0–P0.7	39–32	43–36	I/O	Port 0: Port 0 is an open-drain, bidirectional I/O port. Port 0 pins that have 1s written to them float and can be used as high-impedance inputs. Port 0 is also the multiplexed low-order address and data bus during accesses to external program and data memory. In this application, it uses strong internal pullups when emitting 1s. Port 0 also outputs the code bytes during program verification in the SC87C51. External pull-ups are required during program verification.
P1.0–P1.7	1–8	2–9	I/O	Port 1: Port 1 is an 8-bit bidirectional I/O port with internal pull-ups. Port 1 pins that have 1s written to them are pulled high by the internal pullups and can be used as inputs. As inputs, port 1 pins that are externally pulled low will source current because of the internal pull-ups. (See DC Electrical Characteristics: I _{IL}). Port 1 also receives the low-order address byte during program memory verification.
P2.0–P2.7	21–28	24–31	I/O	Port 2: Port 2 is an 8-bit bidirectional I/O port with internal pull-ups. Port 2 pins that have 1s written to them are pulled high by the internal pullups and can be used as inputs. As inputs, port 2 pins that are externally being pulled low will source current because of the internal pullups. (See DC Electrical Characteristics: I _{IL}). Port 2 emits the high-order address byte during fetches from external program memory and during accesses to external data memory that use 16-bit addresses (MOVX @DPTR). In this application, it uses strong internal pull-ups when emitting 1s. During accesses to external data memory that use 8-bit addresses (MOVX @Ri), port 2 emits the contents of the P2 special function register.
P3.0–P3.7	10–17	11, 13–19	I/O	Port 3: Port 3 is an 8-bit bidirectional I/O port with internal pullups. Port 3 pins that have 1s written to them are pulled high by the internal pullups and can be used as inputs. As inputs, port 3 pins that are externally being pulled low will source current because of the pull-ups. (See DC Electrical Characteristics: I _{IL}). Port 3 also serves the special features of the SC80C51 family, as listed below:
	10	11	I	RxD (P3.0): Serial input port
	11	13	O	TxD (P3.1): Serial output port
	12	14	I	INT0 (P3.2): External interrupt
	13	15	I	INT1 (P3.3): External interrupt
	14	16	I	T0 (P3.4): Timer 0 external input
	15	17	I	T1 (P3.5): Timer 1 external input
	16	18	O	WR (P3.6): External data memory write strobe
	17	19	O	RD (P3.7): External data memory read strobe
RST	9	10	I	Reset: A high on this pin for two machine cycles while the oscillator is running, resets the device. An internal diffused resistor to V _{SS} permits a power-on reset using only an external capacitor to V _{CC} .
ALE/ <u>PROG</u>	30	33	I/O	Address Latch Enable/Program Pulse: Output pulse for latching the low byte of the address during an access to external memory. In normal operation, ALE is emitted at a constant rate of 1/6 the oscillator frequency, and can be used for external timing or clocking. Note that one ALE pulse is skipped during each access to external data memory. This pin is also the program pulse input (PROG) during EPROM programming.
<u>PSEN</u>	29	32	O	Program Store Enable: The read strobe to external program memory. When the SC87C51 is executing code from external program memory, <u>PSEN</u> is activated twice each machine cycle, except that two <u>PSEN</u> activations are skipped during each access to external data memory. <u>PSEN</u> is not activated during fetches from internal program memory.
<u>EA</u> /V _{PP}	31	35	I	External Access Enable/Programming Supply Voltage: <u>EA</u> must be externally held low to enable the device to fetch code from external program memory locations 0000H through 0FFFH. If EA is held high, the device executes from internal program memory unless the program counter contains an address greater than 0FFFH. This pin also receives the 12.75V programming supply voltage (V _{PP}) during EPROM programming.
XTAL1	19	21	I	Crystal 1: Input to the inverting oscillator amplifier and input to the internal clock generator circuits.
XTAL2	18	20	O	Crystal 2: Output from the inverting oscillator amplifier.

CMOS Single-Chip 8-Bit EPROM Microcontroller

SC87C51

OSCILLATOR CHARACTERISTICS

XTAL1 and XTAL2 are the input and output, respectively, of an inverting amplifier. The pins can be configured for use as an on-chip oscillator, as shown in the logic symbol, page 1.

To drive the device from an external clock source, XTAL1 should be driven while XTAL2 is left unconnected. There are no requirements on the duty cycle of the external clock signal, because the input to the internal clock circuitry is through a divide-by-two flip-flop. However, minimum and maximum high and low times specified in the data sheet must be observed.

IDLE MODE

In the idle mode, the CPU puts itself to sleep while all of the on-chip peripherals stay active. The instruction to invoke the idle mode is the last instruction executed

in the normal operating mode before the idle mode is activated. The CPU contents, the on-chip RAM, and all of the special function registers remain intact during this mode. The idle mode can be terminated either by any enabled interrupt (at which time the process is picked up at the interrupt service routine and continued), or by a hardware reset which starts the processor in the same manner as a power-on reset.

POWER-DOWN MODE

In the power-down mode, the oscillator is stopped and the instruction to invoke power-down is the last instruction executed. Only the contents of the on-chip RAM are preserved. A hardware reset is the only way to terminate the power-down mode. The control bits for the reduced power modes are in the special function register PCON.

DESIGN CONSIDERATIONS

At power-on, the voltage on V_{CC} and RST must come up at the same time for a proper start-up.

When the idle mode is terminated by a hardware reset, the device normally resumes program execution, from where it left off, up to two machine cycles before the internal reset algorithm takes control. On-chip hardware inhibits access to internal RAM in this event, but access to the port pins is not inhibited. To eliminate the possibility of an unexpected write when idle is terminated by reset, the instruction following the one that invokes idle should not be one that writes to a port pin or to external memory.

Table 1 shows the state of I/O ports during low current operating modes.

Table 1. External Pin Status During Idle and Power-Down Modes

Mode	Program Memory	ALE	$\overline{\text{PSEN}}$	Port 0	Port 1	Port 2	Port 3
Idle	Internal	1	1	Data	Data	Data	Data
Idle	External	1	1	Float	Data	Address	Data
Power-down	Internal	0	0	Data	Data	Data	Data
Power-down	External	0	0	Float	Data	Data	Data

Electrical Deviations from Commercial Specifications for Extended Temperature Range

D.C. and A.C. parameters not included here are the same as in the commercial temperature range table.

DC ELECTRICAL CHARACTERISTICS T_A = -40°C to +85°C, V_{CC} = 5V ±10%, V_{SS} = 0V

Symbol	Parameter	Test Conditions	Limits		Unit
			Min	Max	
V _{IL}	Input low voltage (except $\overline{\text{EA}}$)		-0.5	0.2V _{CC} -0.15	V
V _{IL1}	$\overline{\text{EA}}$		0	0.2V _{CC} -0.35	V
V _{IH}	Input high voltage (except XTAL1, RST)		0.2V _{CC} +1	V _{CC} +0.5	V
V _{IH1}	Input high voltage to XTAL1, RST		0.7V _{CC} +0.1	V _{CC} +0.5	V
I _{IL}	Logical 0 input current (port 1, 2, 3)	V _{IN} = 0.45V		-75	μA
I _{TL}	Logical 1 to 0 transition current (ports 1, 2, 3)	V _{IN} = 2.0V		-750	μA
I _{CC}	Power supply current Active mode Idle mode Power down mode	V _{CC} = 4.5-5.5V, Frequency range = 3.5 to 12MHz		35 6 50	mA mA μA

CMOS Single-Chip 8-Bit EPROM Microcontroller

SC87C51

ABSOLUTE MAXIMUM RATINGS^{1, 2, 3}

PARAMETER	RATING	UNIT
Operating temperature under bias	0 to +70 or -40 to +85	°C
Storage temperature range	-65 to +150	°C
Voltage on EA/V _{PP} pin to V _{SS}	0 to +13.0	V
Voltage on any other pin to V _{SS}	-0.5 to +6.5	V
Power dissipation (based on package heat transfer limitations, not device power consumption)	1.5	W

NOTES:

- Stresses above those listed under Absolute Maximum Ratings may cause permanent damage to the device. This is a stress rating only and functional operation of the device at these or any conditions other than those described in the AC and DC Electrical Characteristics section of this specification is not implied.
- This product includes circuitry specifically designed for the protection of its internal devices from the damaging effects of excessive static charge. Nonetheless, it is suggested that conventional precautions be taken to avoid applying voltages greater than the rated maxima.
- Parameters are valid over operating temperature range unless otherwise specified. All voltages are with respect to V_{SS} unless otherwise noted.

DC ELECTRICAL CHARACTERISTICS T_A = 0°C to +70°C or -40°C to +85°C, V_{CC} = 5V ±10%, V_{SS} = 0V

Symbol	Parameter	Test Conditions	Limits			Unit
			Min	Typical	Max	
V _{IL}	Input low voltage, except EA ⁷		-0.5		0.2V _{CC} -0.1	V
V _{IL1}	Input low voltage to EA ⁷		0		0.2V _{CC} -0.3	V
V _{IH}	Input high voltage, except XTAL1, RST ⁷		0.2V _{CC} +0.9		V _{CC} +0.5	V
V _{IH1}	Input high voltage, XTAL1, RST ⁷		0.7V _{CC}		V _{CC} +0.5	V
V _{OL}	Output low voltage, ports 1, 2, 3	I _{OL} = 1.6mA ²			0.45	V
V _{OL1}	Output low voltage, port 0, ALE, PSEN	I _{OL} = 3.2mA ²			0.45	V
V _{OH}	Output high voltage, ports 1, 2, 3, ALE, PSEN ³	I _{OH} = -60μA I _{OH} = -25μA I _{OH} = -10μA	2.4 0.75V _{CC} 0.9V _{CC}			V V V
V _{OH1}	Output high voltage (port 0 in external bus mode)	I _{OH} = -800μA I _{OH} = -300μA I _{OH} = -80μA	2.4 0.75V _{CC} 0.9V _{CC}			V V V
I _{IL}	Logical 0 input current, ports 1, 2, 3 ⁷	V _{IN} = 0.45V			-50	μA
I _{TL}	Logical 1-to-0 transition current, ports 1, 2, 3 ⁷	See note 4			-650	μA
I _{LI}	Input leakage current, port 0	V _{IN} = V _{IL} or V _{IH}			±10	μA
I _{CC}	Power supply current: ⁷ Active mode @ 12MHz ⁵ Idle mode @ 12MHz ⁵ Power down mode	See note 6		11.5 1.3 3	25 4 50	mA mA μA
R _{RST}	Internal reset pulldown resistor		50		300	kΩ
C _{IO}	Pin capacitance				10	pF

NOTES:

- Typical ratings are not guaranteed. The values listed are at room temperature, 5V.
- Capacitive loading on ports 0 and 2 may cause spurious noise to be superimposed on the V_{OL}s of ALE and ports 1 and 3. The noise is due to external bus capacitance discharging into the port 0 and port 2 pins when these pins make 1-to-0 transitions during bus operations. In the worst cases (capacitive loading > 100pF), the noise pulse on the ALE pin may exceed 0.8V. In such cases, it may be desirable to qualify ALE with a Schmitt Trigger, or use an address latch with a Schmitt Trigger STROBE input.
- Capacitive loading on ports 0 and 2 may cause the V_{OH} on ALE and PSEN to momentarily fall below the 0.9V_{CC} specification when the address bits are stabilizing.
- Pins of ports 1, 2, and 3 source a transition current when they are being externally driven from 1 to 0. The transition current reaches its maximum value when V_{IN} is approximately 2V.
- I_{CCMAX} at other frequencies is given by:
Active mode: I_{CCMAX} = 0.94 X FREQ + 13.71
Idle mode: I_{CCMAX} = 0.14 X FREQ + 2.31
where FREQ is the external oscillator frequency in MHz. I_{CCMAX} is given in mA. See Figure 8.
- See Figures 9 through 12 for I_{CC} test conditions.
- These values apply only to T_A = 0°C to +70°C. For T_A = -40°C to +85°C, see table on page 4.

CMOS Single-Chip 8-Bit EPROM Microcontroller

SC87C51

AC ELECTRICAL CHARACTERISTICS $T_A = 0^\circ\text{C}$ to $+70^\circ\text{C}$ or -40°C to $+85^\circ\text{C}$, $V_{CC} = 5V \pm 10\%$, $V_{SS} = 0V^{1, 2}$

SYMBOL	FIGURE	PARAMETER	12MHz CLOCK		VARIABLE CLOCK		UNIT
			Min	Max	Min	Max	
Program Memory							
$1/t_{CLCL}$	1	Oscillator frequency: Speed Versions SC87C51 B SC87C51 C SC87C51 G			0.5 3.5 3.5	12 12 16	MHz MHz MHz
t_{LHLL}	1	ALE pulse width	127		$2t_{CLCL}-40$		ns
t_{AVLL}	1	Address valid to ALE low	28		$t_{CLCL}-55$		ns
t_{LLAX}	1	Address hold after ALE low	48		$t_{CLCL}-35$		ns
t_{LLIV}	1	ALE low to valid instruction in		234		$4t_{CLCL}-100$	ns
t_{LLPL}	1	ALE low to PSEN low	43		$t_{CLCL}-40$		ns
t_{PLPH}	1	PSEN pulse width	205		$3t_{CLCL}-45$		ns
t_{PLIV}	1	PSEN low to valid instruction in		145		$3t_{CLCL}-105$	ns
t_{PXIX}	1	Input instruction hold after PSEN	0		0		ns
t_{PXIZ}	1	Input instruction float after PSEN		59		$t_{CLCL}-25$	ns
t_{AVIV}	1	Address to valid instruction in		312		$5t_{CLCL}-105$	ns
t_{PLAZ}	1	PSEN low to address float		10		10	ns
Data Memory							
t_{RLRH}	2, 3	RD pulse width	400		$6t_{CLCL}-100$		ns
t_{WLWH}	2, 3	WR pulse width	400		$6t_{CLCL}-100$		ns
t_{RLDV}	2, 3	RD low to valid data in		252		$5t_{CLCL}-165$	ns
t_{RHDX}	2, 3	Data hold after RD	0		0		ns
t_{RHDZ}	2, 3	Data float after RD		97		$2t_{CLCL}-70$	ns
t_{LLDV}	2, 3	ALE low to valid data in		517		$8t_{CLCL}-150$	ns
t_{AVDV}	2, 3	Address to valid data in		585		$9t_{CLCL}-165$	ns
t_{LLWL}	2, 3	ALE low to RD or WR low	200	300	$3t_{CLCL}-50$	$3t_{CLCL}+50$	ns
t_{AVWL}	2, 3	Address valid to WR low or RD low	203		$4t_{CLCL}-130$		ns
t_{QVWX}	2, 3	Data valid to WR transition	23		$t_{CLCL}-60$		ns
t_{WHQX}	2, 3	Data hold after WR	33		$t_{CLCL}-50$		ns
t_{RLAZ}	2, 3	RD low to address float		0		0	ns
t_{WHLH}	2, 3	RD or WR high to ALE high	43	123	$t_{CLCL}-40$	$t_{CLCL}+40$	ns
External Clock							
t_{CHCX}	5	High time	20		20		ns
t_{CLCX}	5	Low time	20		20		ns
t_{CLCH}	5	Rise time		20		20	ns
t_{CHCL}	5	Fall time		20		20	ns
Shift Register							
t_{XLXL}	4	Serial port clock cycle time	1.0		$12t_{CLCL}$		μs
t_{QVXH}	4	Output data setup to clock rising edge	700		$10t_{CLCL}-133$		ns
t_{XHQX}	4	Output data hold after clock rising edge	50		$2t_{CLCL}-117$		ns
t_{XHDX}	4	Input data hold after clock rising edge	0		0		ns
t_{XHDV}	4	Clock rising edge to input data valid		700		$10t_{CLCL}-133$	ns

NOTES:

- Parameters are valid over operating temperature range unless otherwise specified.
- Load capacitance for port 0, ALE, and PSEN = 100pF, load capacitance for all other outputs = 80pF.

EXPLANATION OF THE AC SYMBOLS

Each timing symbol has five characters. The first character is always 't' (= time). The other characters, depending on their positions, indicate the name of a signal or the logical status of that signal. The designations are:

- A - Address
- C - Clock
- D - Input data
- H - Logic level high
- I - Instruction (program memory contents)
- L - Logic level low, or ALE

- P - PSEN
- Q - Output data
- R - RD signal
- t - Time
- V - Valid
- W - WR signal
- X - No longer a valid logic level
- Z - Float

Examples: t_{AVLL} - Time for address valid to ALE low.
 t_{LLPL} - Time for ALE low to PSEN low.

CMOS Single-Chip 8-Bit EPROM Microcontroller

SC87C51

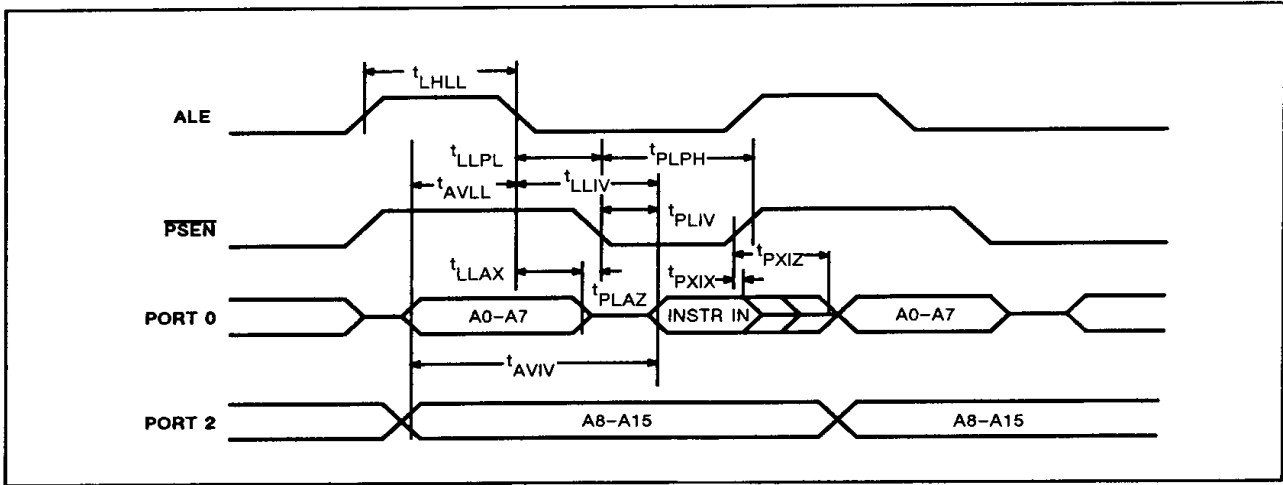

Figure 1. External Program Memory Read Cycle

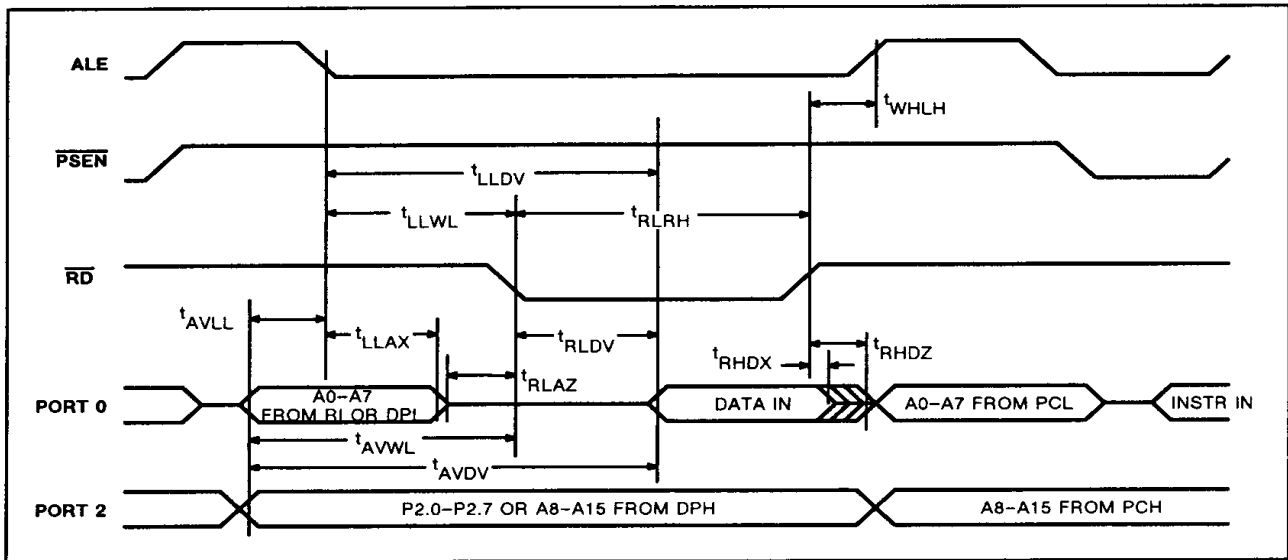

Figure 2. External Data Memory Read Cycle

CMOS Single-Chip 8-Bit EPROM Microcontroller

SC87C51

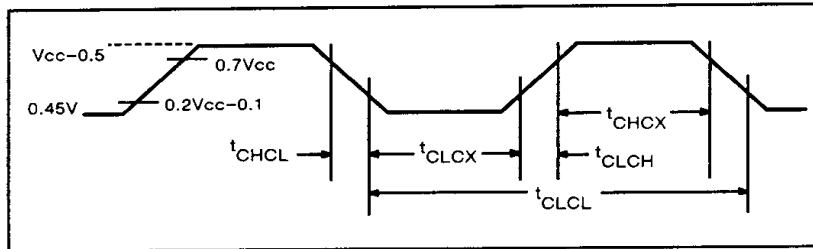

Figure 5. External Clock Drive

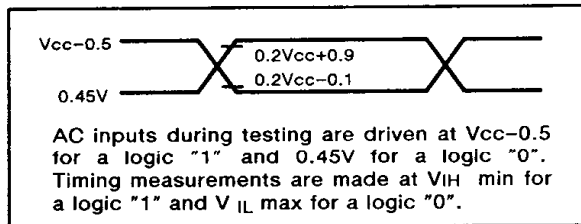

Figure 6. AC Testing Input/Output

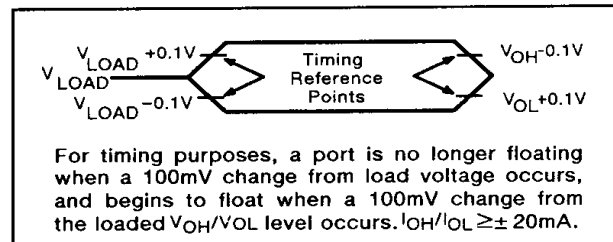

Figure 7. Float Waveform

EPROM CHARACTERISTICS

The SC87C51 is programmed by using a modified Quick-Pulse Programming™ algorithm. It differs from older methods in the value used for V_{PP} (programming supply voltage) and in the width and number of the ALE/PROG pulses.

The SC87C51 contains two signature bytes that can be read and used by an EPROM programming system to identify the device. The signature bytes identify the device as an SC87C51 manufactured by Signetics Corporation.

Table 2 shows the logic levels for reading the signature byte, and for programming the program memory, the encryption table, and the lock bits. The circuit configuration and waveforms for quick-pulse programming are shown in Figures 13 and 14. Figure 15 shows the circuit configuration for normal program memory verification.

QUICK-PULSE PROGRAMMING

The setup for microcontroller quick-pulse programming is shown in Figure 13. Note that the SC87C51 is running with a 4 to 6MHz oscillator. The reason the oscillator needs to be running is that the device is executing internal address and program data transfers.

The address of the EPROM location to be programmed is applied to ports 1 and 2, as shown in Figure 13. The code byte to be programmed into that location is

applied to port 0. RST, \overline{PSEN} and pins of ports 2 and 3 specified in Table 2 are held at the "Program Code Data" levels indicated in Table 2. The ALE/PROG is pulsed low 25 times as shown in Figure 14.

To program the encryption table, repeat the 25 pulse programming sequence for addresses 0 through 1FH, using the "Pgm Encryption Table" levels. Do not forget that after the encryption table is programmed, verification cycles will produce only encrypted data.

To program the lock bits, repeat the 25 pulse programming sequence using the "Pgm Lock Bit" levels. After one lock bit is programmed, further programming of the code memory and encryption table is disabled. However, the other lock bit can still be programmed.

Note that the \overline{EA}/V_{PP} pin must not be allowed to go above the maximum specified V_{PP} level for any amount of time. Even a narrow glitch above that voltage can cause permanent damage to the device. The V_{PP} source should be well regulated and free of glitches and overshoot.

Program Verification

If lock bit 2 has not been programmed, the on-chip program memory can be read out for program verification. The address of the program memory locations to be read is applied to ports 1 and 2 as

shown in Figure 15. The other pins are held at the "Verify Code Data" levels indicated in Table 2. The contents of the address location will be emitted on port 0. External pull-ups are required on port 0 for this operation.

If the encryption table has been programmed, the data presented at port 0 will be the exclusive NOR of the gram byte with one of the encryption bytes. The user will have to know the encryption table contents in order to correctly decode the verification data. The encryption table itself cannot be read out.

Reading the Signature Bytes

The signature bytes are read by the same procedure as a normal verification of locations 030H and 031H, except that P3.6 and P3.7 need to be pulled to a logic low. The values are:

- (030H) - 15H indicates manufactured by Signetics
- (031H) - 92H indicates SC87C51

Program/Verify Algorithms

Any algorithm in agreement with the conditions listed in Table 2, and which satisfies the timing specifications, is suitable.

™Trademark phrase of Intel Corp.

CMOS Single-Chip 8-Bit EPROM Microcontroller

SC87C51

Erasure Characteristics

Erasure of the EPROM begins to occur when the chip is exposed to light with wavelengths shorter than approximately 4,000 angstroms. Since sunlight and fluorescent lighting have wavelengths in this range, exposure to these light sources over an extended time (about 1 week in sunlight, or 3 years in room level fluorescent lighting) could cause inadvertent erasure. **For this and secondary effects, it is recommended that an opaque label be placed over the window.** For elevated temperature or solvent environments, use Kapton tape Fluorglas part number 2345-5 or equivalent.

The recommended erasure procedure is exposure to ultraviolet light (at 2537 angstroms) to an integrated dose of at least 15W-sec/cm². Exposing the EPROM to an ultraviolet lamp of 12,000μW/cm² rating for 20 to 39 minutes, at a distance of about 1 inch, should be sufficient.

Erasure leaves the array in an all 1s state.

Table 2. EPROM Programming Modes

MODE	RST	PSEN	ALE/PROG	EA/V _{PP}	P2.7	P2.6	P3.7	P3.6
Read signature	1	0	1	1	0	0	0	0
Program code data	1	0	0*	V _{PP}	1	0	1	1
Verify code data	1	0	1	1	0	0	1	1
Pgm encryption table	1	0	0*	V _{PP}	1	0	1	0
Pgm lock bit 1	1	0	0*	V _{PP}	1	1	1	1
Pgm lock bit 2	1	0	0*	V _{PP}	1	1	0	0

NOTES:

1. "0" = valid low for that pin, "1" = valid high for that pin.

2. V_{PP} = 12.75V ±0.25V.

3. V_{CC} = 5V ±10% during programming and verification.

*ALE/PROG receives 25 programming pulses while V_{PP} is held at 12.75V. Each programming pulse is low for 100μs (±10μs) and high for a minimum of 10μs.

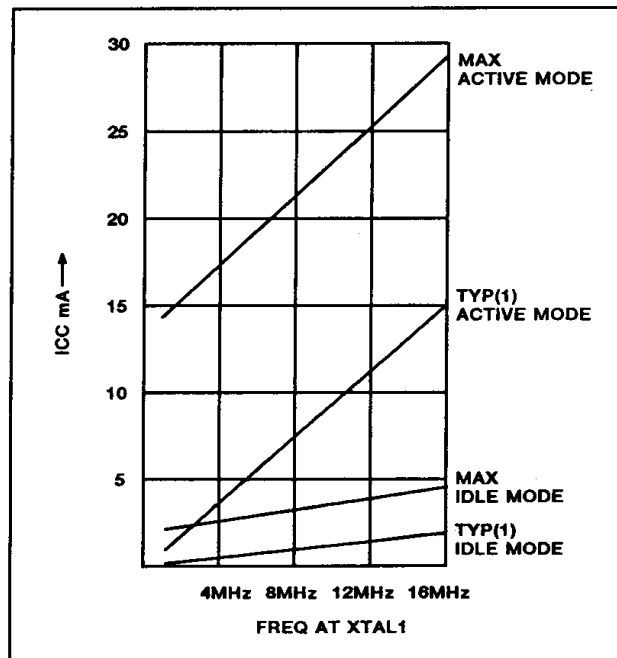

Figure 8. I_{CC} vs. FREQ
Valid only within frequency specifications of the device under test

CMOS Single-Chip 8-Bit EPROM Microcontroller

SC87C51

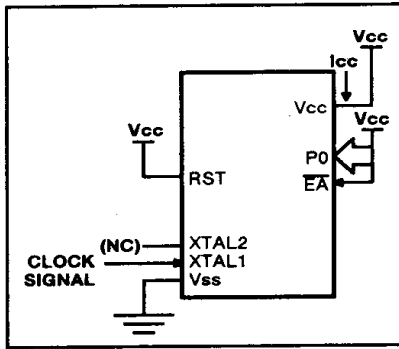

Figure 9. I_{CC} Test Condition, Active Mode
All other pins are disconnected

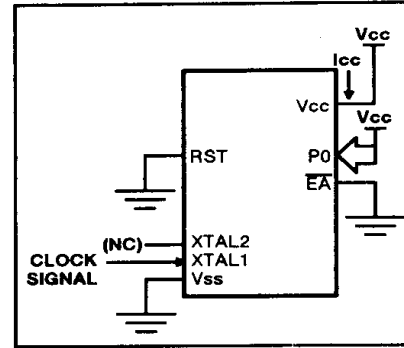

Figure 10. I_{CC} Test Condition, Idle Mode
All other pins are disconnected

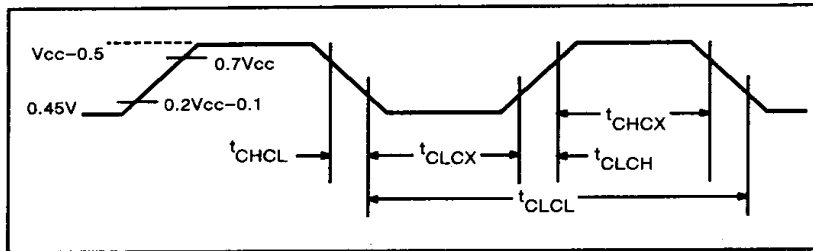

Figure 11. Clock Signal Waveform for I_{CC} Tests in Active and Idle Modes
 $t_{CLCH} = t_{CHCL} = 5ns$

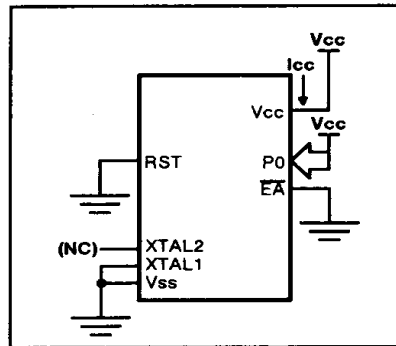

Figure 12. I_{CC} Test Conditions, Power Down Mode
All other pins are disconnected. $V_{CC} = 2V$ to $5.5V$

CMOS Single-Chip 8-Bit EPROM Microcontroller

SC87C51

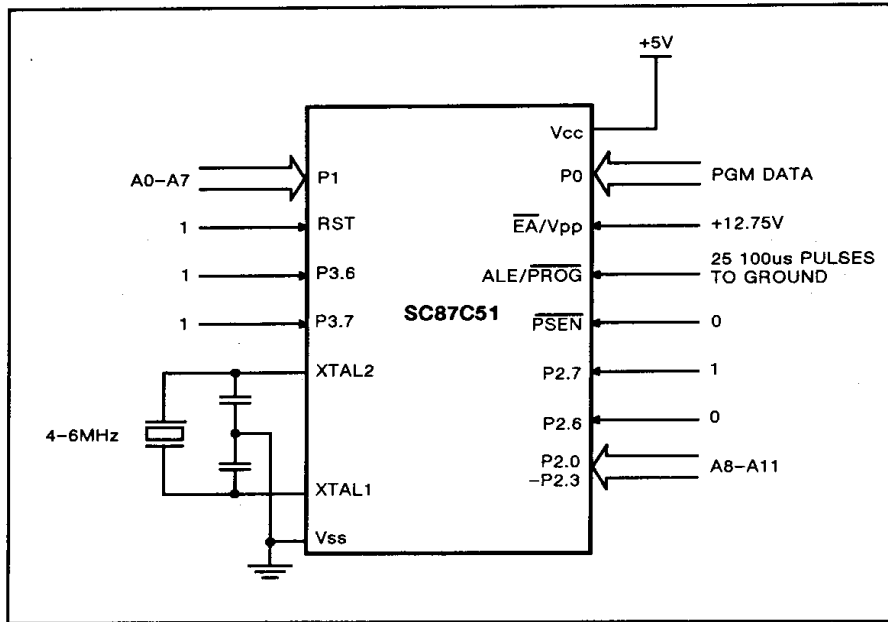

Figure 13. Programming Configuration

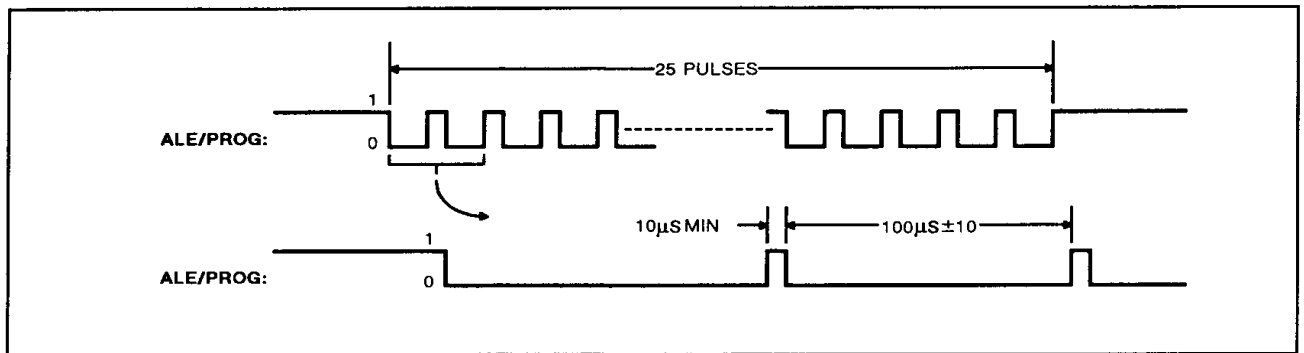

Figure 14. PROG Waveform

CMOS Single-Chip 8-Bit EPROM Microcontroller

SC87C51

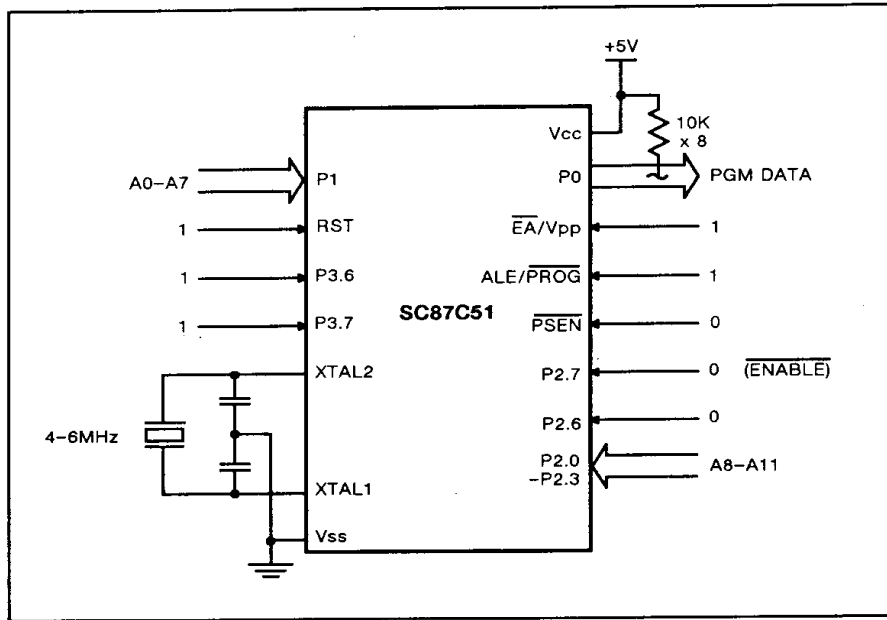

Figure 15. Program Verification

EPROM PROGRAMMING AND VERIFICATION CHARACTERISTICS $T_A = -21^{\circ}\text{C}$ to $+27^{\circ}\text{C}$, $V_{CC} = 5\text{V} \pm 10\%$, $V_{SS} = 0\text{V}$ (see Figure 16)

SYMBOL	PARAMETER	MIN	MAX	UNIT
V_{PP}	Programming supply voltage	12.5	13.0	V
I_{PP}	Programming supply current		50	mA
$1/t_{CLCL}$	Oscillator frequency	4	6	MHz
t_{AVGL}	Address setup to $\overline{\text{PROG}}$ low	$48t_{CLCL}$		
t_{GHAX}	Address hold after $\overline{\text{PROG}}$	$48t_{CLCL}$		
t_{DVGL}	Data setup to $\overline{\text{PROG}}$ low	$48t_{CLCL}$		
t_{GHDX}	Data hold after $\overline{\text{PROG}}$	$48t_{CLCL}$		
t_{EHS}	P2.7 (ENABLE) high to V_{pp}	$48t_{CLCL}$		
t_{SHGL}	V_{pp} setup to $\overline{\text{PROG}}$ low	10		μs
t_{GHSL}	V_{pp} hold after $\overline{\text{PROG}}$	10		μs
t_{GLGH}	$\overline{\text{PROG}}$ width	90	110	μs
t_{AVQV}	Address to data valid		$48t_{CLCL}$	
t_{ELQV}	ENABLE low to data valid		$48t_{CLCL}$	
t_{EHQZ}	Data float after ENABLE	0	$48t_{CLCL}$	
t_{GHGL}	$\overline{\text{PROG}}$ high to $\overline{\text{PROG}}$ low	10		μs

CMOS Single-Chip 8-Bit EPROM Microcontroller

SC87C51

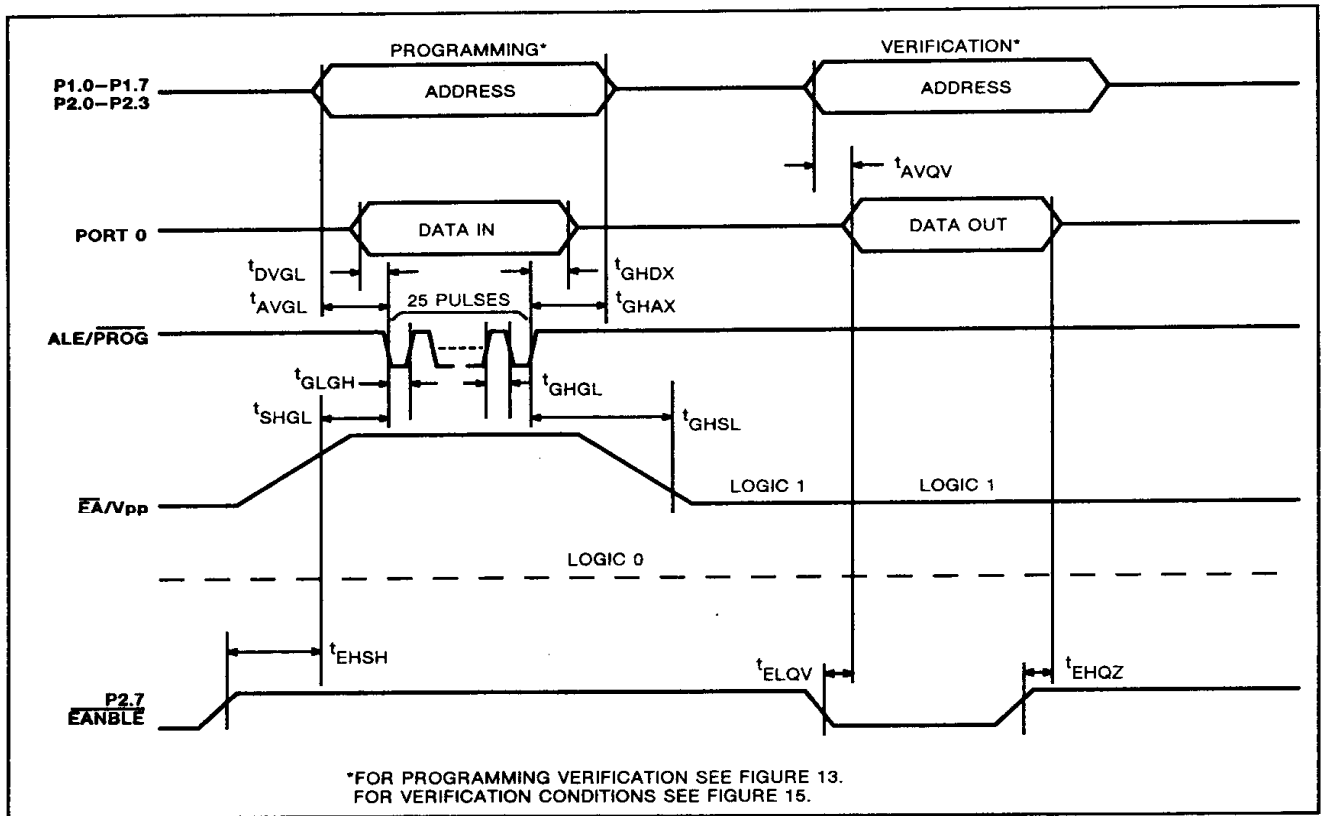

Figure 16. EPROM Programming and Verification