

16-BIT MCU WITH 32K BYTE ROM

- HIGH PERFORMANCE CPU
 - 16-BIT CPU WITH 4-STAGE PIPELINE
 - 80ns INSTRUCTION CYCLE TIME @ 25MHz CLK
 - 400ns 16 X 16-BIT MULTIPLICATION
 - 800ns 32/ 16-BIT DIVISION
 - ENHANCED BOOLEAN BIT MANIPULATION FACILITIES
 - ADDITIONAL INSTRUCTIONS TO SUPPORT HLL AND OPERATING SYSTEMS
 - SINGLE-CYCLE CONTEXT SWITCHING SUPPORT
- MEMORY ORGANIZATION
 - 32K BYTE ON-CHIP ROM MEMORY
 - UP TO 16M BYTE LINEAR ADDRESS SPACE FOR CODE AND DATA (5M BYTE WITH CAN)
 - 2K BYTE ON-CHIP INTERNAL RAM (IRAM)
 - 2K BYTE ON-CHIP EXTENSION RAM (XRAM)
- FAST AND FLEXIBLE BUS
 - PROGRAMMABLE EXTERNAL BUS CHARACTERISTICS FOR DIFFERENT ADDRESS RANGES
 - 8-BIT OR 16-BIT EXTERNAL DATA BUS
 - MULTIPLEXED OR DEMULTIPLEXED EXTERNAL ADDRESS/DATA BUSES
 - FIVE PROGRAMMABLE CHIP-SELECT SIGNALS
 - HOLD-ACKNOWLEDGE BUS ARBITRATION SUPPORT
- INTERRUPT
 - 8-CHANNEL PERIPHERAL EVENT CONTROLLER FOR SINGLE CYCLE, INTERRUPT DRIVEN DATA TRANSFER
 - 16-PRIORITY-LEVEL INTERRUPT SYSTEM WITH 56 SOURCES, SAMPLE-RATE DOWN TO 40ns
- TIMERS
 - TWO MULTI-FUNCTIONAL GENERAL PURPOSE TIMER UNITS WITH 5 TIMERS
 - TWO 16-CHANNEL CAPTURE/COMPARE UNITS
- A/D CONVERTER
 - 16-CHANNEL 10-BIT
 - 7.76µs CONVERSION TIME
- FAIL-SAFE PROTECTION
 - PROGRAMMABLE WATCHDOG TIMER
 - OSCILLATOR WATCHDOG
- ON-CHIP CAN 2.0B INTERFACE
- ON-CHIP BOOTSTRAP LOADER
- CLOCK GENERATION
 - ON-CHIP PLL
 - DIRECT OR PRESCALED CLOCK INPUT

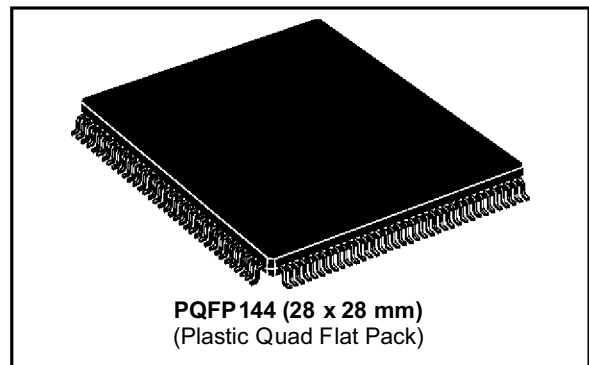

- UP TO 111 GENERAL PURPOSE I/O LINES
 - INDIVIDUALLY PROGRAMMABLE AS INPUT, OUTPUT OR SPECIAL FUNCTION
 - PROGRAMMABLE DRIVE STRENGTH
 - PROGRAMMABLE THRESHOLD (HYSTERESIS)
- IDLE AND POWER DOWN MODES
 - IDLE CURRENT <95mA
 - POWER-DOWN SUPPLY CURRENT <400µA
- 4-CHANNEL PWM UNIT
- SERIAL CHANNELS
 - SYNCHRONOUS/ASYNCSERIAL CHANNEL
 - HIGH-SPEED SYNCHRONOUS CHANNEL
- DEVELOPMENT SUPPORT
 - C-COMPILERS, MACRO-ASSEMBLER PACKAGES, EMULATORS, EVAL BOARDS, HLL-DEBUGGERS, SIMULATORS, LOGIC ANALYZER DISASSEMBLERS, PROGRAMMING BOARDS
- 144-PIN PQFP PACKAGE

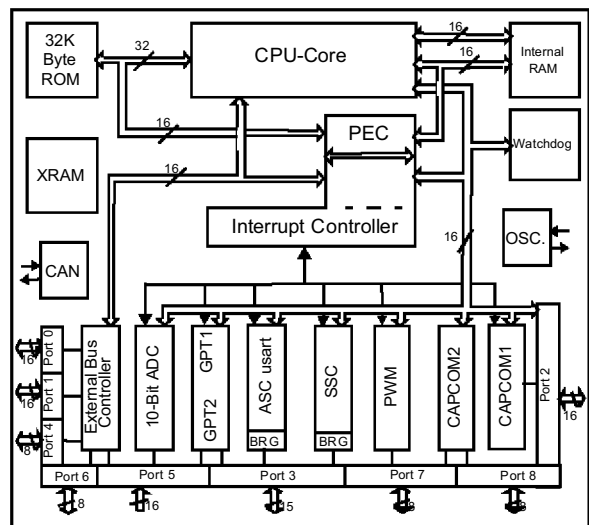

TABLE OF CONTENTS		Page
I	INTRODUCTION.....	4
II	PIN DATA	5
III	FUNCTIONAL DESCRIPTION.....	10
IV	MEMORY ORGANIZATION.....	11
V	CENTRAL PROCESSING UNIT (CPU).....	12
VI	EXTERNAL BUS CONTROLLER.....	13
VII	INTERRUPT SYSTEM	14
VIII	CAPTURE/COMPARE (CAPCOM) UNIT	17
IX	GENERAL PURPOSE TIMER UNIT.....	18
IX.1	GPT1	18
IX.2	GPT2	19
X	PWM MODULE	21
XI	PARALLEL PORTS	22
XII	A/D CONVERTER.....	23
XIII	SERIAL CHANNELS	24
XIV	CAN MODULE	26
XV	WATCHDOG TIMER.....	26
XVI	INSTRUCTION SET SUMMARY	27
XVII	SYSTEM RESET.....	29
XVIII	POWER REDUCTION MODES	30
XIX	SPECIAL FUNCTION REGISTER OVERVIEW.....	31
XIX.1	IDENTIFICATION REGISTERS	37
XX	ELECTRICAL CHARACTERISTICS	38
XX.1	ABSOLUTE MAXIMUM RATINGS	38
XX.2	PARAMETER INTERPRETATION	38
XX.3	DC CHARACTERISTICS	39
XX.3.1	A/D converter characteristics	40
XX.4	AC CHARACTERISTICS	41
XX.4.1	Definition of internal timing	42
XX.4.2	Clock generation modes	42

TABLE OF CONTENTS (continued)		Page
XX.4.3	Prescaler operation	43
XX.4.4	Direct drive	43
XX.4.5	Oscillator watchdog (OWD)	43
XX.4.6	Phase locked loop	43
XX.4.7	Memory cycle variables	44
XX.4.8	External clock drive XTAL1	45
XX.4.9	Multiplexed bus	45
XX.4.10	Demultiplexed bus	52
XX.4.11	CLKOUT and $\overline{\text{READY}}$	58
XX.4.12	External bus arbitration	60
XX.4.13	Highspeed synchronous serial interface (SSC) timing	61
XXI	PACKAGE MECHANICAL DATA	64
XXII	ORDERING INFORMATION	64

I - INTRODUCTION

The ST10C167 is a derivative of the STMicroelectronics ST10 family of 16-bit single-chip CMOS microcontrollers. It combines high CPU performance (up to 12.5 million

instructions per second) with high peripheral functionality and enhanced I/O capabilities.

It also provides on-chip high-speed RAM and clock generation via PLL.

Figure 1 : Logic Symbol

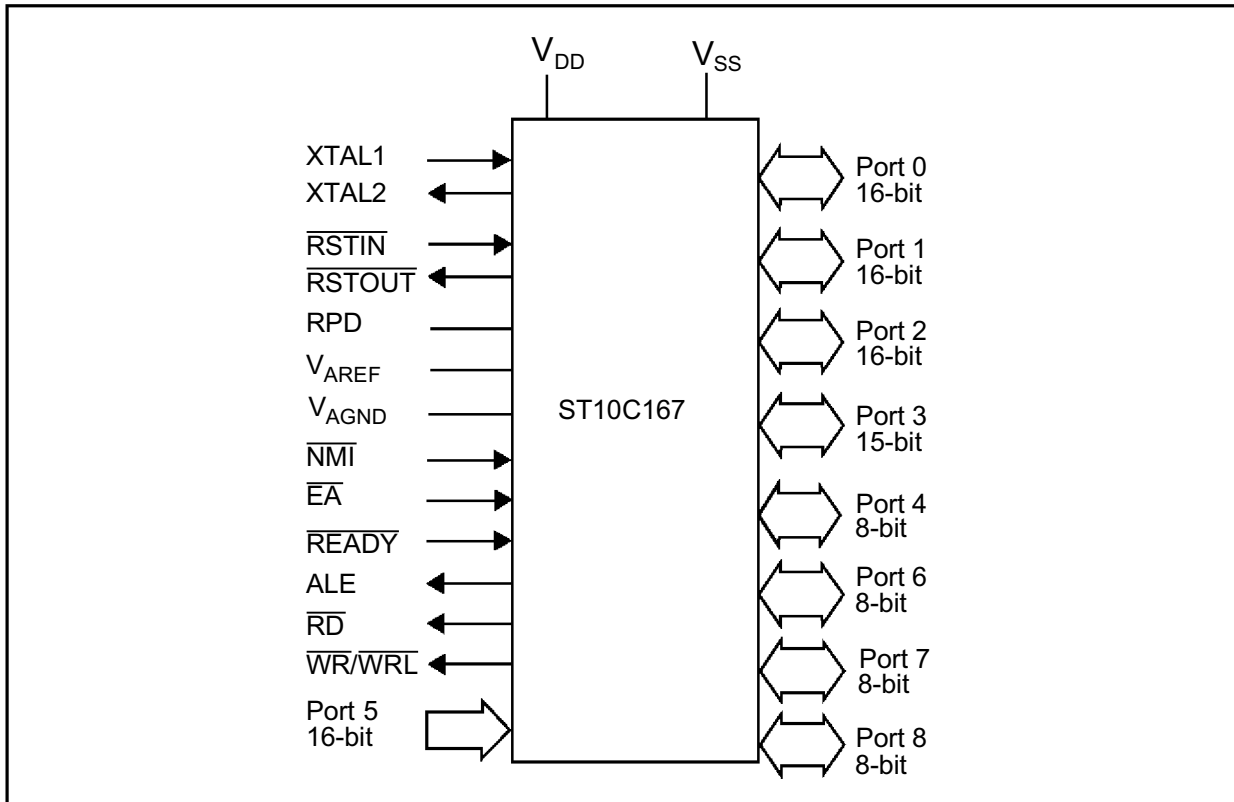

II - PIN DATA

Figure 2 : Pin Configuration (top view)

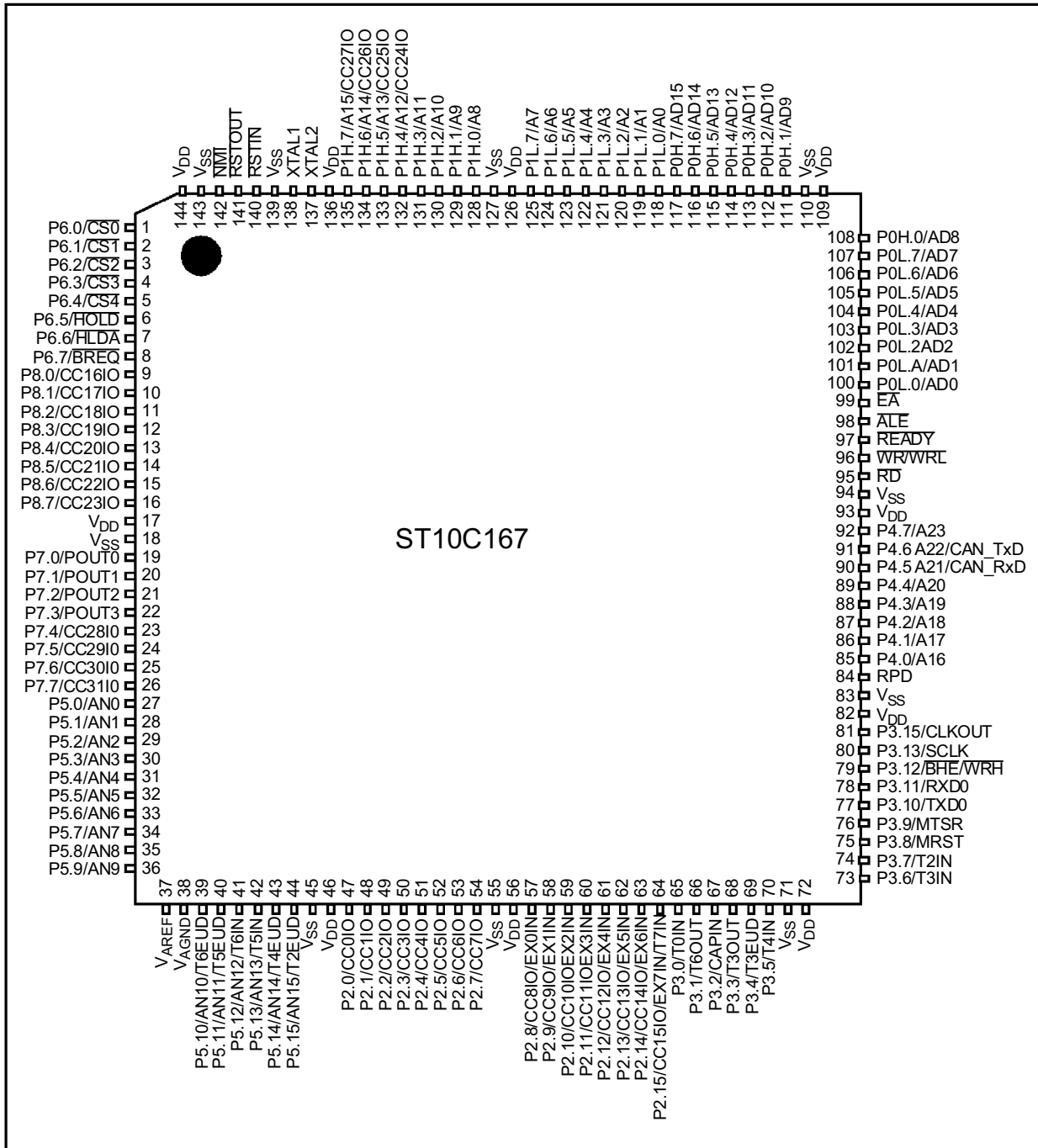

II - PIN DATA (continued)

Table 1 : Pin list

Symbol	Pin	Type	Function
P6.0 - P6.7	1 - 8	I/O	8-bit bidirectional I/O port, bit-wise programmable for input or output via direction bits. Programming an I/O pin as input forces the corresponding output driver to high impedance state. Port 6 outputs can be configured as push/pull or open drain drivers. The following Port 6 pins have alternate functions:
	1	O	P6.0 $\overline{CS0}$ Chip Select 0 Output

	5	O	P6.4 $\overline{CS4}$ Chip Select 4 Output
	6	I	P6.5 \overline{HOLD} External Master Hold Request Input
	7	O	P6.6 \overline{HLDA} Hold Acknowledge Output
	8	O	P6.7 \overline{BREQ} Bus Request Output
P8.0 - P8.7	9 - 16	I/O	8-bit bidirectional I/O port, bit-wise programmable for input or output via direction bits. Programming an I/O pin as input forces the corresponding output driver to high impedance state. Port 8 outputs can be configured as push/pull or open drain drivers. The input threshold of Port 8 is selectable (TTL or special). The following Port 8 pins have alternate functions:
	9	I/O	P8.0 CC16IO CAPCOM2: CC16 Capture Input/Compare Output

	16	I/O	P8.7 CC23IO CAPCOM2: CC23 Capture Input/Compare Output
P7.0 - P7.7	19 - 26	I/O	8-bit bidirectional I/O port, bit-wise programmable for input or output via direction bits. Programming an I/O pin as input forces the corresponding output driver to high impedance state. Port 7 outputs can be configured as push/pull or open drain drivers. The input threshold of Port 7 is selectable (TTL or special). The following Port 7 pins have alternate functions:
	19	O	P7.0 POUT0 PWM Channel 0 Output

	22	O	P7.3 POUT3 PWM Channel 3 Output
	23	I/O	P7.4 CC28IO CAPCOM2: CC28 Capture Input/Compare Output

26	I/O	P7.7 CC31IO CAPCOM2: CC31 Capture Input/Compare Output	
P5.0 - P5.9 P5.10 - P5.15	27 - 36 39 - 44	I I	Port 5 is a 16-bit input-only port with Schmitt-Trigger characteristics. The pins of Port 5 also serve as the (up to 16) analog input channels for the A/D converter, where P5.x equals ANx (Analog input channel x), or they serve as timer inputs:
	39	I	P5.10 T6EUD GPT2 Timer T6 External Up/Down Control Input
	40	I	P5.11 T5EUD GPT2 Timer T5 External Up/Down Control Input
	41	I	P5.12 T6IN GPT2 Timer T6 Count Input
	42	I	P5.13 T5IN GPT2 Timer T5 Count Input
	43	I	P5.14 T4EUD GPT1 Timer T4 External Up/Down Control Input
	44	I	P5.15 T2EUD GPT1 Timer T2 External Up/Down Control Input

II - PIN DATA (continued)

Table 1 : Pin list (continued)

Symbol	Pin	Type	Function
P2.0 - P2.7 P2.8 - P2.15	47 - 54 57 - 64	I/O	16-bit bidirectional I/O port, bit-wise programmable for input or output via direction bits. Programming an I/O pin as input forces the corresponding output driver to high impedance state. Port 2 outputs can be configured as push/pull or open drain drivers. The input threshold of Port 2 is selectable (TTL or special). The following Port 2 pins have alternate functions:
	47	I/O	P2.0 CC0IO CAPCOM: CC0 Capture Input/Compare Output

	54	I/O	P2.7 CC7IO CAPCOM: CC7 Capture Input/Compare Output
	57	I/O	P2.8 CC8IO CAPCOM: CC8 Capture Input/Compare Output
			EX0IN Fast External Interrupt 0 Input

	64	I/O	P2.15 CC15IO CAPCOM: CC15 Capture Input/Compare Output
			EX7IN Fast External Interrupt 7 Input
			T7IN CAPCOM2 Timer T7 Count Input
P3.0 - P3.5 P3.6 - P3.13 P3.15	65 - 70 73 - 80 81	I/O I/O I/O	15-bit (P3.14 is missing) bidirectional I/O port, bit-wise programmable for input or output via direction bits. Programming an I/O pin as input forces the corresponding output driver to high impedance state. Port 3 outputs can be configured as push/pull or open drain drivers. The input threshold of Port 3 is selectable (TTL or special). The following Port 3 pins have alternate functions:
	65	I	P3.0 T0IN CAPCOM Timer T0 Count Input
	66	O	P3.1 T6OUT GPT2 Timer T6 Toggle Latch Output
	67	I	P3.2 CAPIN GPT2 Register CAPREL Capture Input
	68	O	P3.3 T3OUT GPT1 Timer T3 Toggle Latch Output
	69	I	P3.4 T3EUD GPT1 Timer T3 External Up/Down Control Input
	70	I	P3.5 T4IN GPT1 Timer T4 Input for Count/Gate/Reload/Capture
	73	I	P3.6 T3IN GPT1 Timer T3 Count/Gate Input
	74	I	P3.7 T2IN GPT1 Timer T2 Input for Count/Gate/Reload/Capture
	75	I/O	P3.8 MRST SSC Master-Receive/Slave-Transmit I/O
	76	I/O	P3.9 MTSR SSC Master-Transmit/Slave-Receive O/I
	77	I/O	P3.10 TxD0 ASC0 Clock/Data Output (Asynchronous/Synchronous)
	78	O	P3.11 RxD0 ASC0 Data Input (Asyn.) or I/O (Synchronous)
	79	O	P3.12 $\overline{\text{BHE}}$ External Memory High Byte Enable Signal, $\overline{\text{WRH}}$ External Memory High Byte Write Strobe
	80	I/O	P3.13 SCLK SSC Master Clock Output/Slave Clock Input
	81	O	P3.15 CLKOUT System Clock Output (=CPU Clock)
P4.0 - P4.7	85 - 92	I/O	8-bit bidirectional I/O port, bit-wise programmable for input or output via direction bits. Programming an I/O pin as input forces the corresponding output driver to high impedance state. For external bus configuration, Port 4 can be used to output the segment address lines:
	85 - 89	O	P4.0 - P4.4 A16 - A20 Least Significant Segment Address Line
	90	O	P4.5 A21 Segment Address Line
			CAN_RxD CAN Receive Data Input
	91	O	P4.6 A22 Segment Address Line,
			CAN_TxD CAN Transmit Data Output
	92	O	P4.7 A23 Most Significant Segment Address Line
$\overline{\text{RD}}$	95	O	External Memory Read Strobe. $\overline{\text{RD}}$ is activated for every external instruction or data read access.

II - PIN DATA (continued)

Table 1 : Pin list (continued)

Symbol	Pin	Type	Function
$\overline{WR}/\overline{WRL}$	96	O	External Memory Write Strobe. In \overline{WR} -mode this pin is activated for every external data write access. In \overline{WRL} -mode this pin is activated for low byte data write accesses on a 16-bit bus, and for every data write access on an 8-bit bus. See WRCFG in register SYSCON for mode selection.
READY/ \overline{READY}	97	I	Ready Input. The active level is programmable. When the Ready function is enabled, the selected inactive level at this pin during an external memory access will force the insertion of memory cycle time waitstates until the pin returns to the selected active level.
ALE	98	O	Address Latch Enable Output. Can be used for latching the address into external memory or an address latch in the multiplexed bus modes.
\overline{EA}	99	I	External Access Enable pin. A low level at this pin during and after Reset forces the ST10C167 to begin instruction execution out of external memory. A high level forces execution out of the internal Flash Memory.
P0L.0 - P0L.7 P0H.0 P0H.1 - P0H.7	100 - 107 108 111 - 117	I/O	Port 0 consists of the two 8-bit bidirectional I/O ports P0L and P0H. It is bit-wise programmable for input or output via direction bits. For a pin configured as input, the output driver is put into high-impedance state. In case of an external bus configuration, Port 0 serves as the address (A) and address/data (AD) bus in multiplexed bus modes and as the data (D) bus in demultiplexed bus modes. Demultiplexed bus modes: Data Path Width : 8-bit 16-bit P0L.0 – P0L.7 : D0 – D7 D0 - D7 P0H.0 – P0H.7 : I/O D8 - D15 Multiplexed bus modes: Data Path Width : 8-bit 16-bit P0L.0 – P0L.7 : AD0 – AD7 AD0 - AD7 P0H.0 – P0H.7 : A8 - A15 AD8 - AD15
P1L.0 - P1L.7 P1H.0 - P1H.7	118 - 125 128 - 135	I/O	Port 1 consists of the two 8-bit bidirectional I/O ports P1L and P1H. It is bit-wise programmable for input or output via direction bits. For a pin configured as input, the output driver is put into high-impedance state. Port 1 is used as the 16-bit address bus (A) in demultiplexed bus modes and also after switching from a demultiplexed bus mode to a multiplexed bus mode. The following PORT1 pins also serve for alternate functions:
	132	I	P1H.4 CC24IO CAPCOM2: CC24 Capture Input
	133	I	P1H.5 CC25IO CAPCOM2: CC25 Capture Input
	134	I	P1H.6 CC26IO CAPCOM2: CC26 Capture Input
	135	I	P1H.7 CC27IO CAPCOM2: CC27 Capture Input
XTAL1	138	I	Input to the oscillator amplifier and input to the internal clock generator
XTAL2	137	O	Output of the oscillator amplifier circuit. To clock the device from an external source, drive XTAL1, while leaving XTAL2 unconnected. Minimum and maximum high/low and rise/fall times specified in the AC Characteristics must be observed.
\overline{RSTIN}	140	I	Reset Input with Schmitt-Trigger characteristics. A low level at this pin for a specified duration while the oscillator is running resets the ST10C167. An internal pullup resistor permits power-on reset using only a capacitor connected to V_{SS} . In bidirectional reset mode (enabled by setting bit BDRSTEN in SYSCON register), the \overline{RSTIN} line is pulled low for the duration of the internal reset sequence.

II - PIN DATA (continued)

Table 1 : Pin list (continued)

Symbol	Pin	Type	Function
$\overline{\text{RSTOUT}}$	141	O	Internal Reset Indication Output. This pin is set to a low level when the part is executing either a hardware-, a software- or a watchdog-timer reset. $\overline{\text{RSTOUT}}$ remains low until the EINIT (end of initialization) instruction is executed.
$\overline{\text{NMI}}$	142	I	Non-Maskable Interrupt Input. A high to low transition at this pin causes the CPU to vector to the NMI trap routine. If bit PWDCFG = '0' in SYSCON register, when the PWRDN (power down) instruction is executed, the $\overline{\text{NMI}}$ pin must be low in order to force the ST10C167 to go into power down mode. If $\overline{\text{NMI}}$ is high and PWDCFG = '0', when PWRDN is executed, the part will continue to run in normal mode. If not used, pin $\overline{\text{NMI}}$ should be pulled high externally.
V_{AREF}	37	-	Reference voltage for the A/D converter.
V_{AGND}	38	-	Reference ground for the A/D converter.
RPD	84	-	This pin is used as the timing pin for the return from powerdown circuit and power-up asynchronous reset.
V_{DD}	17, 46, 56, 72, 82, 93, 109, 126, 136, 144	-	Digital Supply Voltage: = + 5V during normal operation and idle mode. ≥ + 2.5V during power down mode
V_{SS}	18, 45, 55, 71, 83, 94, 110, 127, 139, 143	-	Digital Ground.

III - FUNCTIONAL DESCRIPTION

The architecture of the ST10C167 combines advantages of both RISC and CISC processors and an advanced peripheral subsystem. The

block diagram gives an overview of the different on-chip components and the high bandwidth internal bus structure of the ST10C167.

Figure 3 : Block diagram

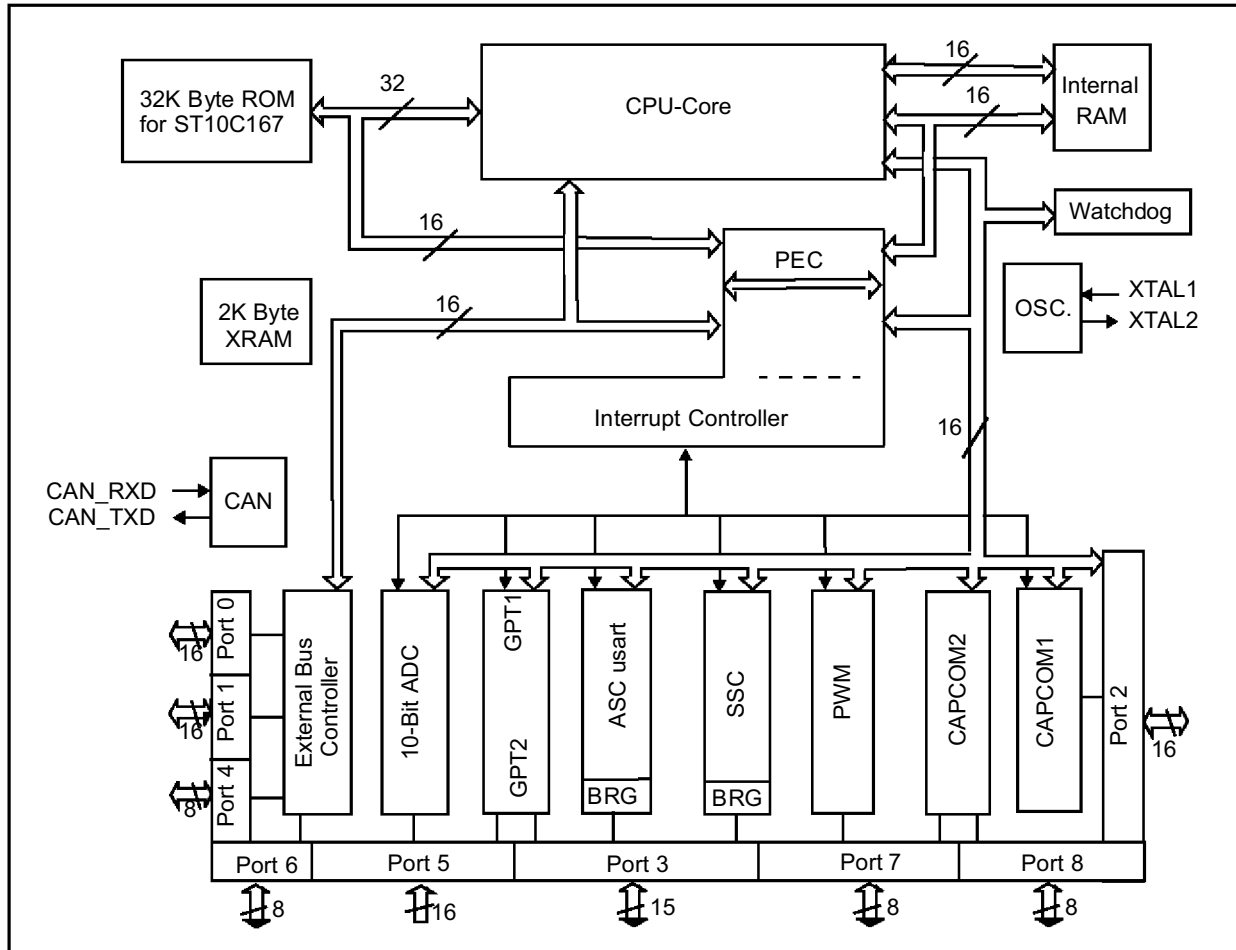

IV - MEMORY ORGANIZATION

The memory space of the ST10C167 is configured in a Von-Neumann architecture. Code memory, data memory, registers and I/O ports are organized within the same linear address space of 16M Byte.

The entire memory space can be accessed Byte-wise or Wordwise. Particular portions of the on-chip memory have additionally been made directly bit addressable.

ROM : 32K Byte of on-chip ROM.

RAM : 2K Byte of on-chip internal RAM (dual-port) is provided as a storage for data, system stack, general purpose register banks and code. The register bank can consist of up to 16 wordwide (R0 to R15) and/or Byte-wide (RL0, RH0, ..., RL7, RH7) general purpose registers.

XRAM : 2K Byte of on-chip extension RAM (single port XRAM) is provided as a storage for data, user stack and code.

The XRAM is connected to the internal XBUS and is accessed like an external memory in 16-bit demultiplexed bus-mode without waitstate or read/write delay (80ns access at 25MHz CPU clock). Byte and Word access is allowed.

The XRAM address range is 00'E000h - 00'E7FFh if the XRAM is enabled (XPEN bit 2 of SYSCON register). As the XRAM appears like external memory, it cannot be used for the ST10C167's system stack or register banks. The

XRAM is not provided for single bit storage and therefore is not bit addressable. If bit XRAMEN is cleared, then any access in the address range 00'E000h - 00'E7FFh will be directed to external memory interface, using the BUSCONx register corresponding to address matching ADDRSELx register.

SFR/ESFR : 1024 Byte (2 * 512 Byte) of address space is reserved for the special function register areas. SFRs are wordwide registers which are used for controlling and monitoring functions of the different on-chip units.

CAN : Address range 00'EF00h - 00'EFFh is reserved for the CAN Module access. The CAN is enabled by setting XPEN bit 2 of the SYSCON register. Accesses to the CAN Module use demultiplexed addresses and a 16-bit data bus (Byte accesses are possible). Two wait states give an access time of 160ns at 25MHz CPU clock. No tristate waitstate is used.

Note If the CAN module is used, Port 4 can not be programmed to output all 8 segment address lines. Thus, only 4 segment address lines can be used, reducing the external memory space to 5M Byte (1M Byte per CS line).

In order to meet the needs of designs where more memory is required than is provided on chip, up to 16M Byte of external RAM and/or ROM can be connected to the microcontroller.

V - CENTRAL PROCESSING UNIT (CPU)

The CPU includes a 4-stage instruction pipeline, a 16-bit arithmetic and logic unit (ALU) and dedicated SFRs. Additional hardware has been added for a separate multiply and divide unit, a bit-mask generator and a barrel shifter.

Most of the ST10C167's instructions can be executed in one instruction cycle which requires 80ns at 25MHz CPU clock. For example, shift and rotate instructions are processed in one instruction cycle independent of the number of bits to be shifted. Multiple-cycle instructions have been optimized: branches are carried out in 2 cycles, 16 x 16 bit multiplication in 5 cycles and a 32/16 bit division in 10 cycles. The jump cache reduces the execution time of repeatedly performed jumps in a loop, from 2 cycles to 1 cycle.

The CPU uses an actual register context consisting of up to 16 Word wide GPRs physically allocated within the on-chip RAM area. A Context Pointer (CP) register determines the base address of the active register bank to be accessed by the CPU. The number of register banks is only restricted by the available internal RAM space. For easy parameter passing, a register bank may overlap others.

A system stack of up to 1024 Byte is provided as a storage for temporary data. The system stack is allocated in the on-chip RAM area, and it is accessed by the CPU via the stack pointer (SP) register. Two separate SFRs, STKOV and STKUN, are implicitly compared against the stack pointer value upon each stack access for the detection of a stack overflow or underflow.

Figure 4 : CPU Block Diagram

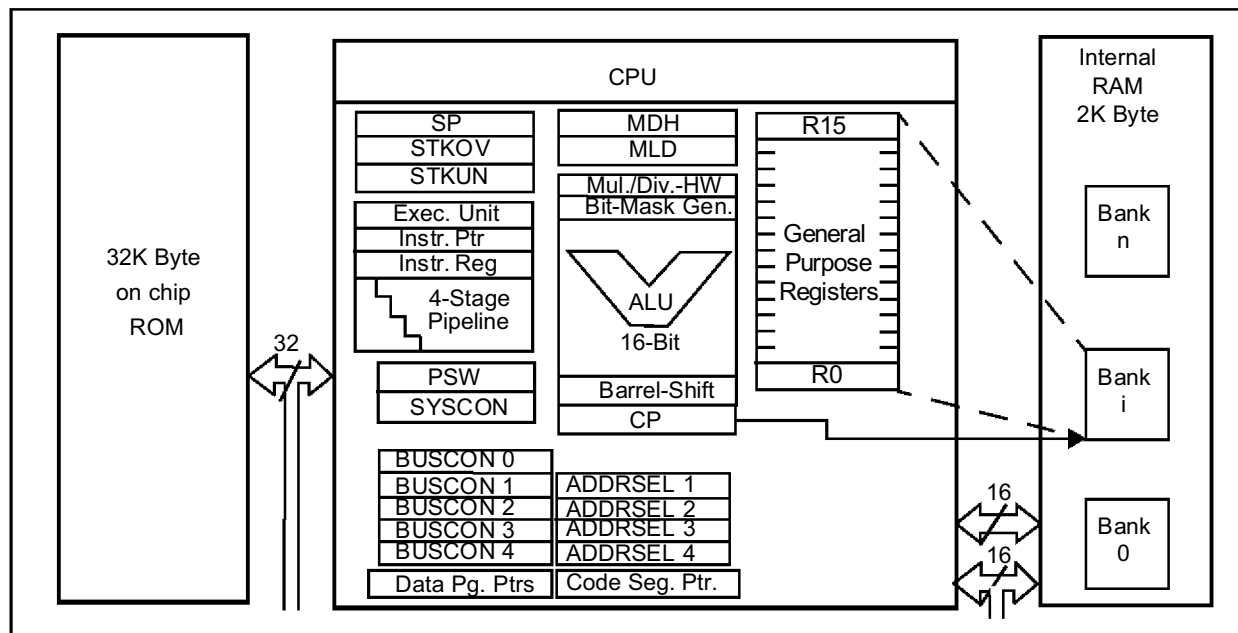

VI - EXTERNAL BUS CONTROLLER

All of the external memory accesses are performed by the on-chip external bus controller. The EBC can be programmed to single chip mode when no external memory is required, or to one of four different external memory access modes:

- 16-/18-/20-/24-bit addresses and 16-bit data, demultiplexed.
- 16-/18-/20-/24-bit addresses and 16-bit data, multiplexed.
- 16-/18-/20-/24-bit addresses and 8-bit data, multiplexed.
- 16-/18-/20-/24-bit addresses and 8-bit data, demultiplexed.

In demultiplexed bus modes addresses are output on Port1 and data is input/output on Port0 or POL, respectively. In the multiplexed bus modes both addresses and data use Port0 for input/output.

Timing characteristics of the external bus interface (memory cycle time, memory tri-state time, length of ALE and read/write delay) are programmable giving the choice of a wide range of memories and external peripherals. Up to 4 independent address windows may be defined (using register pairs ADDRSELx / BUSCONx) to access different resources and bus characteristics. These address windows are arranged hierarchically where BUSCON4 overrides BUSCON3 and BUSCON2 overrides BUSCON1. All accesses to locations not covered by these 4 address windows are controlled by BUSCON0. Up to 5 external \overline{CS} signals (4 windows plus default) can be generated in order to save external glue logic. Access to very slow memories is supported by a 'Ready' function.

A $\overline{HOLD}/\overline{HLDA}$ protocol is available for bus arbitration which shares external resources with other bus masters. The bus arbitration is enabled by setting bit HLDEN in register SYSCON. After setting HLDEN once, pins P6.7...P6.5 (\overline{BREQ} , \overline{HLDA} , \overline{HOLD}) are automatically controlled by the EBC. In master mode (default after reset) the \overline{HLDA} pin is an output. By setting bit DP6.7 to '1' the slave mode is selected where pin \overline{HLDA} is switched to input. This directly connects the slave controller to another master controller without glue logic.

For applications which require less external memory space, the address space can be restricted to 1M Byte, 256K Byte or to 64K Byte. Port 4 outputs all 8 address lines if an address space of 16M Byte is used, otherwise four, two or no address lines.

Chip select timing can be made programmable. By default (after reset), the CSx lines change half a CPU clock cycle after the rising edge of ALE. With the CSCFG bit set in the SYSCON register the CSx lines change with the rising edge of ALE.

The active level of the READY pin can be set by bit RDYPOL in the BUSCONx registers. When the READY function is enabled for a specific address window, each bus cycle within the window must be terminated with the active level defined by bit RDYPOL in the associated BUSCON register.

VII - INTERRUPT SYSTEM

The interrupt response time for internal program execution is from 200ns to 480ns.

The ST10C167 architecture supports several mechanisms for fast and flexible response to service requests that can be generated from various sources internal or external to the microcontroller. Any of these interrupt requests can be serviced by the Interrupt Controller or by the Peripheral Event Controller (PEC).

In contrast to a standard interrupt service where the current program execution is suspended and a branch to the interrupt vector table is performed, just one cycle is 'stolen' from the current CPU activity to perform a PEC service. A PEC service implies a single Byte or Word data transfer between any two memory locations with an additional increment of either the PEC source or the destination pointer. An individual PEC transfer counter is implicitly decremented for each PEC service except when performing in the continuous transfer mode. When this counter reaches zero, a standard interrupt is performed to the corresponding source related vector location. PEC services are very well suited, for example, for supporting the transmission or reception of blocks of data. The ST10C167 has 8 PEC channels each of

which offers such fast interrupt-driven data transfer capabilities.

A interrupt control register which contains an interrupt request flag, an interrupt enable flag and an interrupt priority bitfield is dedicated to each existing interrupt source. Thanks to its related register, each source can be programmed to one of sixteen interrupt priority levels. Once starting to be processed by the CPU, an interrupt service can only be interrupted by a higher prioritized service request. For the standard interrupt processing, each of the possible interrupt sources has a dedicated vector location.

Fast external interrupt inputs are provided to service external interrupts with high precision requirements. These fast interrupt inputs feature programmable edge detection (rising edge, falling edge or both edges).

Software interrupts are supported by means of the 'TRAP' instruction in combination with an individual trap (interrupt) number.

Table 2 shows all the available ST10C167 interrupt sources and the corresponding hardware-related interrupt flags, vectors, vector locations and trap (interrupt) numbers :

Table 2 : Interrupt sources

Source of Interrupt or PEC Service Request	Request Flag	Enable Flag	Interrupt Vector	Vector Location	Trap Number
CAPCOM Register 0	CC0IR	CC0IE	CC0INT	00'0040h	10h
CAPCOM Register 1	CC1IR	CC1IE	CC1INT	00'0044h	11h
CAPCOM Register 2	CC2IR	CC2IE	CC2INT	00'0048h	12h
CAPCOM Register 3	CC3IR	CC3IE	CC3INT	00'004Ch	13h
CAPCOM Register 4	CC4IR	CC4IE	CC4INT	00'0050h	14h
CAPCOM Register 5	CC5IR	CC5IE	CC5INT	00'0054h	15h
CAPCOM Register 6	CC6IR	CC6IE	CC6INT	00'0058h	16h
CAPCOM Register 7	CC7IR	CC7IE	CC7INT	00'005Ch	17h
CAPCOM Register 8	CC8IR	CC8IE	CC8INT	00'0060h	18h
CAPCOM Register 9	CC9IR	CC9IE	CC9INT	00'0064h	19h
CAPCOM Register 10	CC10IR	CC10IE	CC10INT	00'0068h	1Ah
CAPCOM Register 11	CC11IR	CC11IE	CC11INT	00'006Ch	1Bh
CAPCOM Register 12	CC12IR	CC12IE	CC12INT	00'0070h	1Ch
CAPCOM Register 13	CC13IR	CC13IE	CC13INT	00'0074h	1Dh
CAPCOM Register 14	CC14IR	CC14IE	CC14INT	00'0078h	1Eh
CAPCOM Register 15	CC15IR	CC15IE	CC15INT	00'007Ch	1Fh
CAPCOM Register 16	CC16IR	CC16IE	CC16INT	00'00C0h	30h
CAPCOM Register 17	CC17IR	CC17IE	CC17INT	00'00C4h	31h

VII - INTERRUPT SYSTEM (continued)

Table 2 : Interrupt sources (continued)

Source of Interrupt or PEC Service Request	Request Flag	Enable Flag	Interrupt Vector	Vector Location	Trap Number
CAPCOM Register 18	CC18IR	CC18IE	CC18INT	00'00C8h	32h
CAPCOM Register 19	CC19IR	CC19IE	CC19INT	00'00CCh	33h
CAPCOM Register 20	CC20IR	CC20IE	CC20INT	00'00D0h	34h
CAPCOM Register 21	CC21IR	CC21IE	CC21INT	00'00D4h	35h
CAPCOM Register 22	CC22IR	CC22IE	CC22INT	00'00D8h	36h
CAPCOM Register 23	CC23IR	CC23IE	CC23INT	00'00DCh	37h
CAPCOM Register 24	CC24IR	CC24IE	CC24INT	00'00E0h	38h
CAPCOM Register 25	CC25IR	CC25IE	CC25INT	00'00E4h	39h
CAPCOM Register 26	CC26IR	CC26IE	CC26INT	00'00E8h	3Ah
CAPCOM Register 27	CC27IR	CC27IE	CC27INT	00'00ECh	3Bh
CAPCOM Register 28	CC28IR	CC28IE	CC28INT	00'00E0h	3Ch
CAPCOM Register 29	CC29IR	CC29IE	CC29INT	00'0110h	44h
CAPCOM Register 30	CC30IR	CC30IE	CC30INT	00'0114h	45h
CAPCOM Register 31	CC31IR	CC31IE	CC31INT	00'0118h	46h
CAPCOM Timer 0	T0IR	T0IE	T0INT	00'0080h	20h
CAPCOM Timer 1	T1IR	T1IE	T1INT	00'0084h	21h
CAPCOM Timer 7	T7IR	T7IE	T7INT	00'00F4h	3Dh
CAPCOM Timer 8	T8IR	T8IE	T8INT	00'00F8h	3Eh
GPT1 Timer 2	T2IR	T2IE	T2INT	00'0088h	22h
GPT1 Timer 3	T3IR	T3IE	T3INT	00'008Ch	23h
GPT1 Timer 4	T4IR	T4IE	T4INT	00'0090h	24h
GPT2 Timer 5	T5IR	T5IE	T5INT	00'0094h	25h
GPT2 Timer 6	T6IR	T6IE	T6INT	00'0098h	26h
GPT2 CAPREL Register	CRIR	CRIE	CRINT	00'009Ch	27h
A/D Conversion Complete	ADCIR	ADCIE	ADCINT	00'00A0h	28h
A/D Overrun Error	ADEIR	ADEIE	ADEINT	00'00A4h	29h
ASC0 Transmit	S0TIR	S0TIE	S0TINT	00'00A8h	2Ah
ASC0 Transmit Buffer	S0TBIR	S0TBIE	S0TBINT	00'011Ch	47h
ASC0 Receive	S0RIR	S0RIE	S0RINT	00'00ACh	2Bh
ASC0 Error	S0EIR	S0EIE	S0EINT	00'00B0h	2Ch
SSC Transmit	SCTIR	SCTIE	SCTINT	00'00B4h	2Dh
SSC Receive	SCRIR	SCRIE	SCRINT	00'00B8h	2Eh
SSC Error	SCEIR	SCEIE	SCEINT	00'00BCh	2Fh
PWM Channel 0...3	PWMIR	PWMIE	PWMINT	00'00FCh	3Fh
CAN Interface	XP0IR	XP0IE	XP0INT	00'0100h	40h
X-Peripheral Node	XP1IR	XP1IE	XP1INT	00'0104h	41h
X-Peripheral Node	XP2IR	XP2IE	XP2INT	00'0108h	42h
PLL Unlock	XP3IR	XP3IE	XP3INT	00'010Ch	43h

VII - INTERRUPT SYSTEM (continued)

Hardware traps are exceptions or error conditions that arise during run-time. They cause immediate non-maskable system reaction similar to a standard interrupt service (branching to a dedicated vector table location).

The occurrence of a hardware trap is additionally signified by an individual bit in the trap flag regis-

ter (TFR). Except when another higher prioritized trap service is in progress, a hardware trap will interrupt any actual program execution. In turn, hardware trap services can normally not be interrupted by standard or PEC interrupts.

Table 3 shows all of the possible exceptions or error conditions that can arise during run-time:

Table 3 : Exceptions or error conditions that can arise during run time

Exception Condition	Trap Flag	Trap Vector	Vector Location	Trap Number	Trap Priority
Reset Functions:					
Hardware Reset		RESET	00'0000h	00h	III
Software Reset		RESET	00'0000h	00h	III
Watchdog Timer Overflow		RESET	00'0000h	00h	III
Class A Hardware Traps:					
Non-Maskable Interrupt	NMI	NMITRAP	00'0008h	02h	II
Stack Overflow	STKOF	STOTRAP	00'0010h	04h	II
Stack Underflow	STKUF	STUTRAP	00'0018h	06h	II
Class B Hardware Traps:					
Undefined Opcode	UNDOPC	BTRAP	00'0028h	0Ah	I
Protected Instruction Fault	PRTFLT	BTRAP	00'0028h	0Ah	I
Illegal Word Operand	ILLOPA	BTRAP	00'0028h	0Ah	I
Access	ILLINA	BTRAP	00'0028h	0Ah	I
Illegal Instruction Access	ILLBUS	BTRAP	00'0028h	0Ah	I
Illegal External Bus Access					
Reserved			[2Ch – 3Ch]	[0Bh – 0Fh]	
Software Traps					
TRAP Instruction			Any [00'0000h– 00'01FCh] in steps of 4h	Any [00h – 7Fh]	Current CPU Priority

VIII - CAPTURE/COMPARE (CAPCOM) UNIT

The ST10C167 has two 16 channel CAPCOM units. They support generation and control of timing sequences on up to 32 channels with a maximum resolution of 320ns at 25MHz CPU clock. The CAPCOM units are typically used to handle high speed I/O tasks such as pulse and waveform generation, pulse width modulation (PWM), Digital to Analog (D/A) conversion, software timing, or time recording relative to external events.

Four 16-bit timers (T0/T1, T7/T8) with reload registers provide two independent time bases for the capture/compare register array.

The input clock for the timers is programmable to several prescaled values of the internal system clock, or may be derived from an overflow/underflow of timer T6 in module GPT2. This provides a wide range of variation for the timer period and resolution and allows precise adjustments to application specific requirements. In addition, external count inputs for CAPCOM timers T0 and T7 allow event scheduling for the capture/compare registers relative to external events.

Each of the two capture/compare register arrays contain 16 dual purpose capture/compare registers, each of which may be individually allocated to either CAPCOM timer T0 or T1 (T7 or T8, respectively), and programmed for capture or compare functions. Each register has one associated port pin which serves as an input pin

for triggering the capture function, or as an output pin (except for CC24...CC27) to indicate the occurrence of a compare event.

When a capture/compare register has been selected for capture mode, the current contents of the allocated timer will be latched (captured) into the capture/compare register in response to an external event at the port pin which is associated with this register. In addition, a specific interrupt request for this capture/compare register is generated. Either a positive, a negative, or both a positive and a negative external signal transition at the pin can be selected as the triggering event. The contents of all registers which have been selected for one of the five compare modes are continuously compared with the contents of the allocated timers. When a match occurs between the timer value and the value in a capture/compare register, specific actions will be taken based on the selected compare mode (see Table 4).

The input frequencies f_{Tx} for Tx are determined as a function of the CPU clocks. The formulas are detailed in the user manual. The timer input frequencies, resolution and periods which result from the selected pre-scaler option in TxI when using a 25MHz CPU clock are listed in the table below. The numbers for the timer periods are based on a reload value of 0000_H. Note that some numbers may be rounded to 3 significant figures (see Table 5).

Table 4 : Compare modes

Compare Modes	Function
Mode 0	Interrupt-only compare mode ; several compare interrupts per timer period are possible
Mode 1	Pin toggles on each compare match ; several compare events per timer period are possible
Mode 2	Interrupt-only compare mode ; only one compare interrupt per timer period is generated
Mode 3	Pin set '1' on match; pin reset '0' on compare time overflow ; only one compare event per timer period is generated
Double Register Mode	Two registers operate on one pin; pin toggles on each compare match ; several compare events per timer period are possible.

Table 5 : CAPCOM timer input frequencies, resolution and periods

$f_{CPU} = 25MHz$	Timer Input Selection TxI							
	000 _B	001 _B	010 _B	011 _B	100 _B	101 _B	110 _B	111 _B
Pre-scaler for f_{CPU}	8	16	32	64	128	256	512	1024
Input Frequency	3.125MHz	1.56MHz	781KHz	391KHz	195KHz	97.7KHz	48.8KHz	24.4KHz
Resolution	320ns	640ns	1.28 μ s	2.56 μ s	5.12 μ s	10.24 μ s	20.48 μ s	40.96 μ s
Period	21.0ms	41.9ms	83.9ms	167ms	336ms	671ms	1.34s	2.68s

IX - GENERAL PURPOSE TIMER UNIT

The GPT unit is a flexible multifunctional timer/counter structure which is used for time related tasks such as event timing and counting, pulse width and duty cycle measurements, pulse generation, or pulse multiplication. The GPT unit contains five 16-bit timers organized into two separate modules GPT1 and GPT2. Each timer in each module may operate independently in several different modes, or may be concatenated with another timer of the same module.

IX.1 - GPT1

Each of the three timers T2, T3, T4 of the GPT1 module can be configured individually for one of four basic modes of operation: **timer**, **gated timer**, **counter mode** and **incremental interface mode**. In timer mode, the input clock for a timer is derived from the CPU clock, divided by a programmable prescaler. In counter mode, the timer is clocked in reference to external events. Pulse width or duty cycle measurement is supported in gated timer mode where the operation of a timer is controlled by the 'gate' level on an external input pin. For these purposes, each timer has one associated port pin (TxIN) which is the gate or the clock input.

The table below lists the timer input frequencies, resolution and periods for each pre-scaler option at 25MHz CPU clock. This also applies to the Gated Timer Mode of T3 and to the auxiliary timers T2 and T4 in Timer and Gated Timer Mode (see Table 6).

The count direction (up/down) for each timer is programmable by software or may additionally be

altered dynamically by an external signal on a port pin (TxEUD).

In Incremental Interface Mode, the GPT1 timers (T2, T3, T4) can be directly connected to the incremental position sensor signals A and B by their respective inputs TxIN and TxEUD. Direction and count signals are internally derived from these two input signals so that the contents of the respective timer Tx corresponds to the sensor position. The third position sensor signal TOP0 can be connected to an interrupt input.

Timer T3 has output toggle latches (TxOTL) which changes state on each timer over-flow/underflow. The state of this latch may be output on port pins (TxOUT) e. g. for time out monitoring of external hardware components, or may be used internally to clock timers T2 and T4 for high resolution measurement of long time periods.

In addition to their basic operating modes, timers T2 and T4 may be configured as reload or capture registers for timer T3. When used as capture or reload registers, timers T2 and T4 are stopped. The contents of timer T3 is captured into T2 or T4 in response to a signal at their associated input pins (TxIN). Timer T3 is reloaded with the contents of T2 or T4 triggered either by an external signal or by a selectable state transition of its toggle latch T3OTL. When both T2 and T4 are configured to alternately reload T3 on opposite state transitions of T3OTL with the low and high times of a PWM signal, this signal can be constantly generated without software intervention.

Table 6 : GPT1 timer input frequencies, resolution and periods

$f_{CPU} = 25\text{MHz}$	Timer Input Selection T2I / T3I / T4I							
	000 _B	001 _B	010 _B	011 _B	100 _B	101 _B	110 _B	111 _B
Pre-scaler factor	8	16	32	64	128	256	512	1024
Input Frequency	3.125MHz	1.563MHz	781.3KHz	390.6KHz	195.3KHz	97.66KHz	48.83KHz	24.41KHz
Resolution	320ns	640ns	1.28 μ s	2.56 μ s	5.12 μ s	10.24 μ s	20.48 μ s	40.96 μ s
Period	21.0ms	41.9ms	83.9ms	167ms	336ms	671ms	1.34s	2.68s

IX - GENERAL PURPOSE TIMER UNIT (continued)

Figure 5 : Block diagram of GPT1

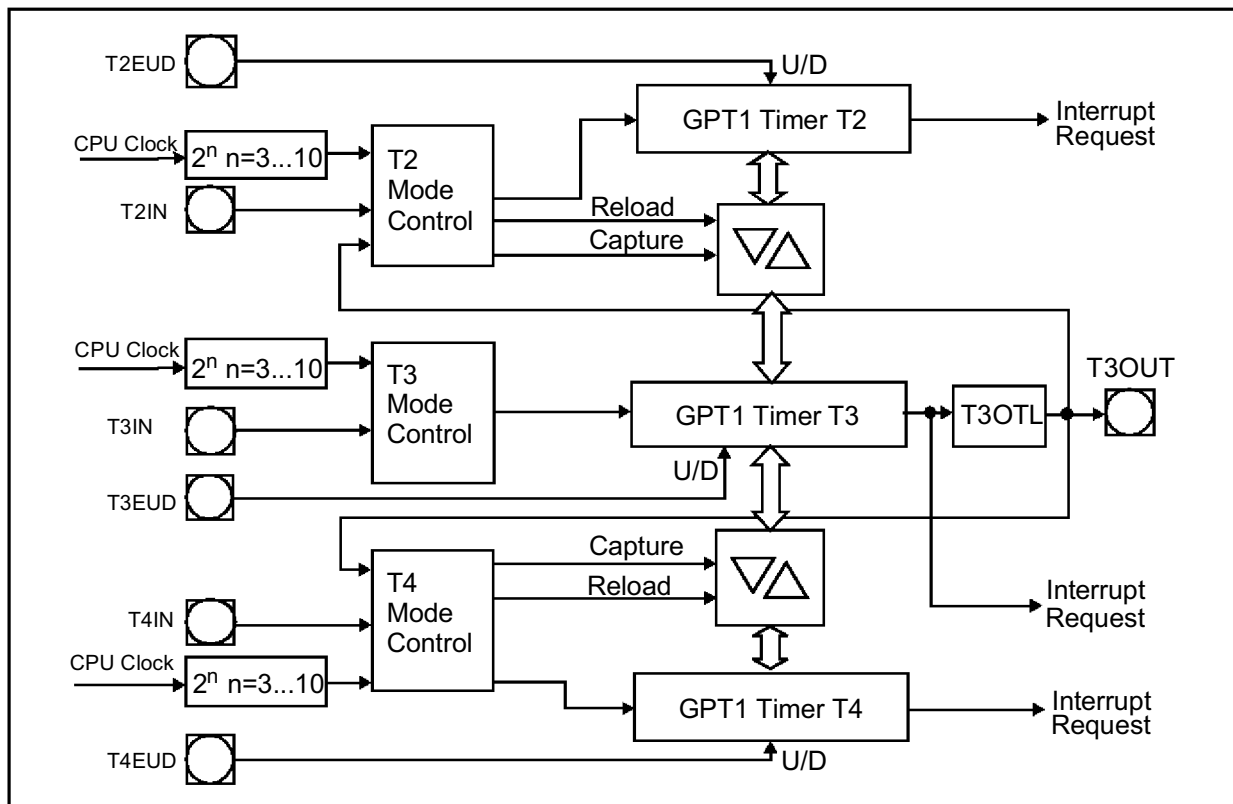

IX.2 - GPT2

The GPT2 module provides precise event control and time measurement. It includes two timers (T5, T6) and a capture/reload register (CAPREL). Both timers can be clocked with an input clock which is derived from the CPU clock via a programmable prescaler or with external signals. The count direction (up/down) for each timer is programmable by software or may additionally be altered dynamically by an external signal on a port pin (TxEUD). Concatenation of the timers is supported via the output toggle latch (T6OTL) of timer T6 which changes its state on each timer overflow/underflow.

The state of this latch may be used to clock timer T5, or it may be output on a port pin (T6OUT). The overflows/underflows of timer T6 can additionally be used to clock the CAPCOM timers T0 or T1, and to cause a reload from the CAPREL register.

The CAPREL register may capture the contents of timer T5 based on an external signal transition on the corresponding port pin (CAPIN), and timer T5 may optionally be cleared after the capture procedure. This allows absolute time differences to be measured or pulse multiplication to be performed without software overhead.

The capture trigger (timer T5 to CAPREL) may also be generated upon transitions of GPT1 timer T3 inputs T3IN and/or T3EUD. This is advantageous when T3 operates in Incremental Interface Mode.

Table 7 lists the timer input frequencies, resolution and periods for each pre-scaler option at 25MHz CPU clock.

This also applies to the Gated Timer Mode of T6 and to the auxiliary timer T5 in Timer and Gated Timer Mode.

IX - GENERAL PURPOSE TIMER UNIT (continued)

Table 7 : GPT2 timer input frequencies, resolution and periods

f _{CPU} = 25MHz	Timer Input Selection T5I / T6I							
	000B	001B	010B	011B	100B	101B	110B	111B
Pre-scaler factor	4	8	16	32	64	128	256	512
Input Frequency	6.25MHz	3.125MHz	1.563MHz	781.3KHz	390.6KHz	195.3KHz	97.66KHz	48.83KHz
Resolution	160ns	320ns	640ns	1.28µs	2.56µs	5.12µs	10.24µs	20.48µs
Period	10.49ms	21.0ms	41.9ms	83.9ms	167ms	336ms	671ms	1.34s

Figure 6 : Block diagram of GPT2

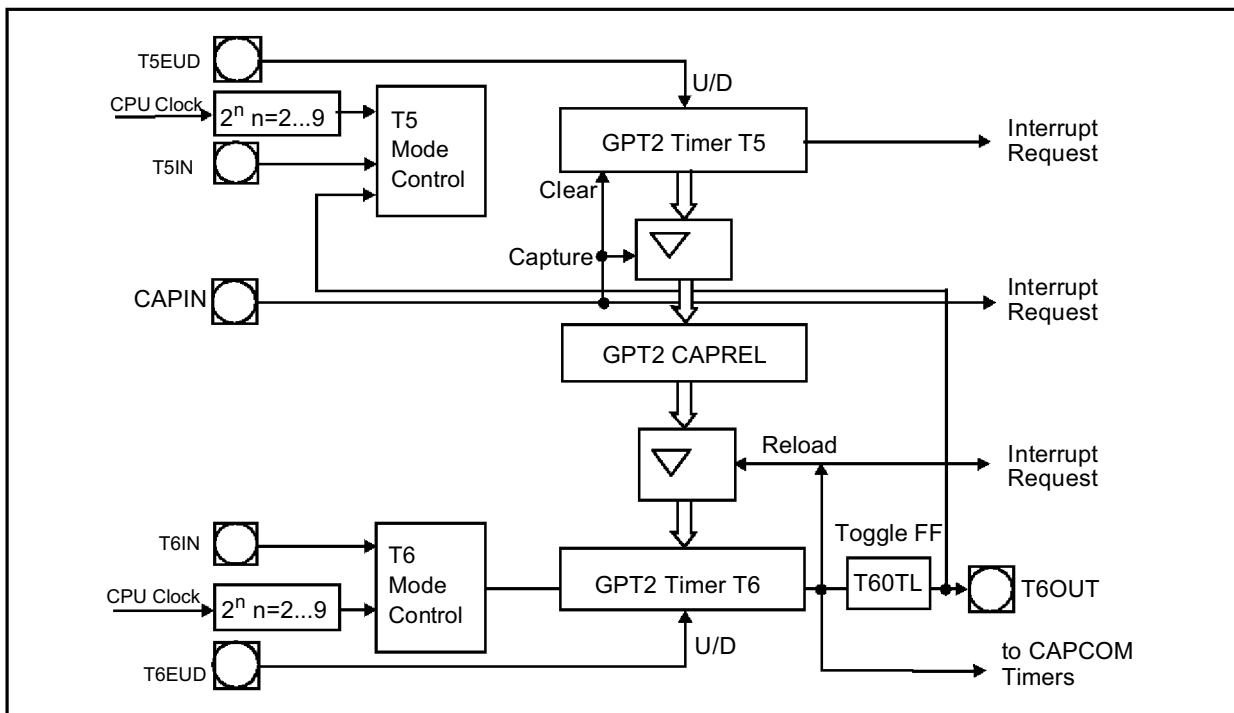

X - PWM MODULE

The pulse width modulation module can generate up to four PWM output signals using edge-aligned or centre-aligned PWM. In addition, the PWM module can generate PWM burst signals and sin-

gle shot outputs. Table 8 shows the PWM frequencies for different resolutions. The level of the output signals is selectable and the PWM module can generate interrupt requests.

Table 8 : PWM unit frequencies and resolution at 25MHz clock

Mode 0	Resolution	8-bit	10-bit	12-bit	14-bit	16-bit
CPU Clock/1	40ns	97.66KHz	24.41KHz	6.104KHz	1.526KHz	0.381KHz
CPU Clock/64	2.56ns	1.526KHz	381.5Hz	95.37Hz	23.84Hz	5.96Hz
Mode 1	Resolution	8-bit	10-bit	12-bit	14-bit	16-bit
CPU Clock/1	40ns	48.82KHz	12.20KHz	3.05KHz	762.9Hz	190.7Hz
CPU Clock/64	2.56ns	762.9Hz	190.7 Hz	47.68Hz	11.92Hz	2.98Hz

Figure 7 : Block diagram of PWM module

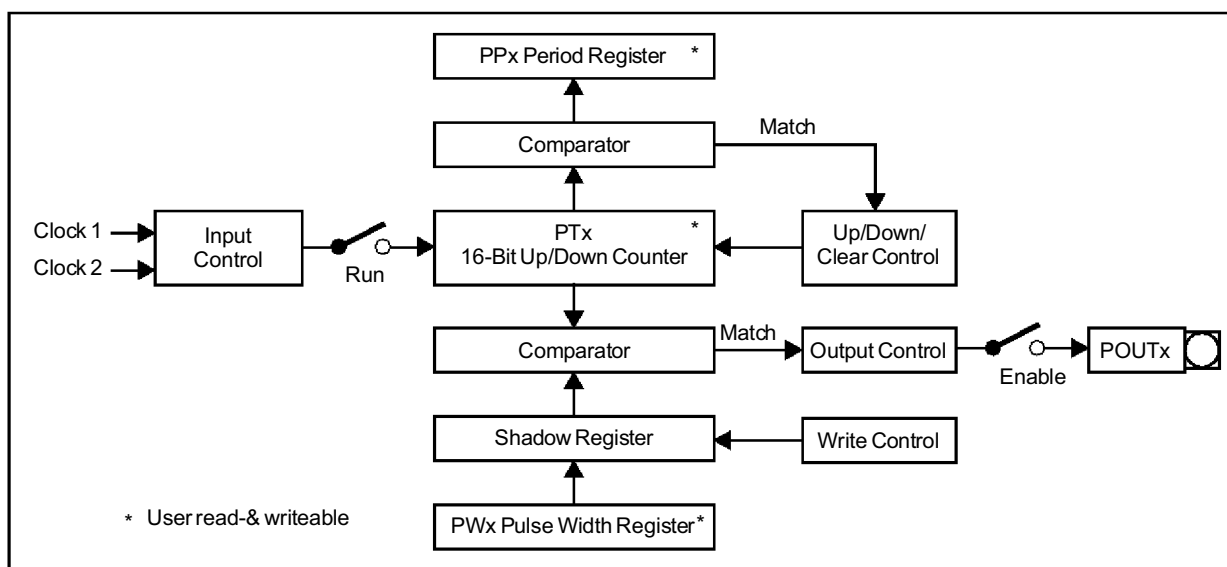

XI - PARALLEL PORTS

The ST10C167 provides up to 111 I/O lines organized into eight input/output ports and one input port.

All port lines are bit-addressable, and all input/output lines are individually (bit-wise) programmable as input or output via direction registers. The I/O ports are true bidirectional ports which are switched to high impedance state when configured as inputs.

The output drivers of five I/O ports can be configured (pin by pin) for push/pull operation or open-drain operation via control registers. During the internal reset, all port pins are configured as inputs.

The input threshold of Port 2, Port 3, Port 7 and Port 8 is selectable (TTL-or CMOS-like), where the special CMOS-like input threshold reduces noise sensitivity due to the input hysteresis.

The input thresholds are selected with bit of PICON register dedicated to blocks of 8 input pins (2-bit for port2, 2-bit for port3, 1-bit for port7, 1-bit for port8).

All pins of I/O ports also support an alternate programmable function:

- Port0 and Port1 may be used as address and data lines when accessing external memory.
- Port 2, Port 7 and Port 8 are associated with the capture inputs or with the compare outputs of the CAPCOM units and/or with the outputs of the PWM module.
- Port 3 includes the alternate functions of timers, serial interfaces, the optional bus control signal \overline{BHE} and the system clock output (CLKOUT).
- Port 4 outputs the additional segment address bits A16 to A23 in systems where segmentation is enabled to access more than 64K Byte of memory.
- Port 5 is used as analog input channels of the A/D converter or as timer control signals.
- Port 6 provides optional bus arbitration signals (\overline{BREQ} , \overline{HLDA} , \overline{HOLD}) and chip select signals.

All port lines that are not used for alternate functions may be used as general purpose I/O lines.

XII - A/D CONVERTER

A 10-bit A/D converter with 16 multiplexed input channels and a sample and hold circuit is integrated on-chip. The sample time (for loading the capacitors) and the conversion time is programmable and can be adjusted to the external circuitry. Overrun error detection/protection is controlled by the ADDAT register. Either an interrupt request is generated when the result of a previous conversion has not been read from the result register at the time the next conversion is complete, or the next conversion is suspended until the previous result has been read. For applications which require less than 16 analog input channels, the remaining channel inputs can be used as digital input port pins. The AD converter of the ST10F168 supports different conversion modes :

- **Single channel single conversion** : the analog level of the selected channel is sampled once and converted. The result of the conversion is stored in the ADDAT register.
- **Single channel continuous conversion** : the analog level of the selected channel is repeatedly sampled and converted. The result of the conversion is stored in the ADDAT register.
- **Auto scan single conversion** : the analog level of the selected channels are sampled once and converted. After each conversion the result is stored in the ADDAT register. The data can be transferred to the RAM by interrupt software management or using the powerful Peripheral Event Controller data transfert.
- **Auto scan continuous conversion** : the analog level of the selected channels are repeatedly sampled and converted. The result of the conversion is stored in the ADDAT register. The data can be transferred to the RAM by interrupt software management or using the powerful Peripheral Event Controller data transfert.
- **Wait for ADDAT read mode** : when using continuous modes, in order to avoid to overwrite the result of the current conversion by the next one, the ADWR bit of ADCON control register

must be activated. Then, until the ADDAT register is read, the new result is stored in a temporary buffer and the conversion is on hold.

- **Channel injection mode** : when using continuous modes, a selected channel can be converted in between without changing the current operating mode. The 10 bit data of the conversion are stored in ADRES field of ADDAT2. The current continuous mode remains active after the single conversion is completed.

The Table : 9 ADC sample clock and conversion time shows the ADC unit conversion clock, sample clock.

A complete conversion will take $14t_{CC} + 2 t_{SC} + 4 TCL$. This time includes the conversion it-self, the sampling time and the time required to transfer the digital value to the result register. For example, at 25MHz of CPU clock, minimum complete conversion time is 7.76 μ s.

The A/D converter provides automatic offset and linearity self calibration. The calibration operation is performed in two ways:

- A full calibration sequence is performed after a reset and lasts 1.6ms minimum (at 25MHz CPU clock). During this time, the ADBSY flag is set to indicate the operation. Normal conversion can be performed during this time. The duration of the calibration sequence is then extended by the time consumed by the conversions.

Note : After a power-on reset, the total unadjusted error (TUE) of the ADC might be worse than $\pm 2LSB$ (max. $\pm 4LSB$). During the full calibration sequence, the TUE is constantly improved until at the end of the cycle, TUE is within the specified limits of $\pm 2LSB$.

- One calibration cycle is performed after each conversion : each calibration cycle takes 4 ADC clock cycles. These operation cycles ensure constant updating of the ADC accuracy, compensating changing operating conditions.

Table 9 : ADC sample clock and conversion time

ADCTC	Conversion Clock t_{CC}		ADSTC	Sample Clock t_{SC}	
	TCL ¹ = $1/2 \times f_{XTAL}$	At $f_{CPU} = 25MHz$		-	At $f_{CPU} = 25MHz$
00	TCL x 24	0.48 μ s	00	t_{CC}	0.48 μ s ²
01	Reserved, do not use	-	01	$t_{CC} \times 2$	0.96 μ s ²
10	TCL x 96	1.92 μ s	10	$t_{CC} \times 4$	1.92 μ s ²
11	TCL x 48	0.96 μ s	11	$t_{CC} \times 8$	3.84 μ s ²

Note 1. See chapter XX.
2. $t_{CC} = TCL \times 24$.

XIII - SERIAL CHANNELS

Serial communication with other microcontrollers, processors, terminals or external peripheral components is provided by two serial interfaces: the asynchronous/synchronous serial channel (ASC0) and the high-speed synchronous serial channel (SSC).

Two dedicated Baud rate generators set up all standard Baud rates without the requirement of oscillator tuning.

For transmission, reception and erroneous reception, 3 separate interrupt vectors are provided for each serial channel.

ASCO

ASCO supports full-duplex asynchronous communication up to 781.25K Baud and half-duplex synchronous communication up to 5M Baud at 25MHz system clock. For asynchronous operation, the Baud rate generator provides a clock with 16 times the rate of the established Baud rate.

The table below lists various commonly used Baud rates together with the required reload values and the deviation errors compared to the intended Baud rate (see Table 10).

For synchronous operation, the Baud rate generator provides a clock with 4 times the rate of the established Baud rate.

Table 10 : Commonly used Baud rates by reload value and deviation errors

S0BRS = '0', f _{CPU} = 25MHz			S0BRS = '1', f _{CPU} = 25MHz		
Baud Rate (Baud)	Deviation Error	Reload Value	Baud Rate (Baud)	Deviation Error	Reload Value
781250	±0.0%	0000 _H	520833	±0.0%	0000 _H
56000	+7.3% / -0.4%	000C _H / 000D _H	56000	+3.3% / -7.0%	0008 _H / 0009 _H
38400	+1.7% / -3.1%	0013 _H / 0014 _H	38400	+4.3% / -3.1%	000C _H / 000D _H
19200	+1.7% / -0.8%	0027 _H / 0028 _H	19200	+0.5% / -3.1%	001A _H / 001B _H
9600	+0.5% / -0.8%	0050 _H / 0051 _H	9600	+0.5% / -1.4%	0035 _H / 0036 _H
4800	+0.5% / -0.1%	00A1 _H / 00A2 _H	4800	+0.5% / -0.5%	006B _H / 006C _H
2400	+0.2% / -0.1%	0144 _H / 0145 _H	2400	+0.0% / -0.5%	00D8 _H / 00D9 _H
1200	+0.0% / -0.1%	028A _H / 028B _H	1200	+0.0% / -0.2%	01B1 _H / 01B2 _H
600	+0.0% / -0.1%	0515 _H / 0516 _H	600	+0.0% / -0.1%	0363 _H / 0364 _H
95	+0.4% / 0.4%	1FFF _H / 1FFF _H	75	+0.0% / 0.0%	1B1F _H / 1B20 _H
			63	+0.9% / 0.9%	1FFF _H / 1FFF _H

Note The deviation errors given in the table above are rounded. Using a Baud rate crystal will provide correct Baud rates without deviation errors.

XIII - SERIAL CHANNELS (continued)**High Speed Synchronous Serial Channel (SSC)**

The High-Speed Synchronous Serial Interface SSC provides flexible high-speed serial communication between the ST10C167 and other microcontrollers, microprocessors or external peripherals.

The SSC supports full-duplex and half-duplex synchronous communication; The serial clock signal can be generated by the SSC itself (master mode) or be received from an external master (slave mode). Data width, shift direction, clock polarity and phase are programmable. This allows

communication with SPI-compatible devices. Transmission and reception of data is double-buffered. A 16-bit Baud rate generator provides the SSC with a separate serial clock signal. The serial channel SSC has its own dedicated 16-bit Baud rate generator with 16-bit reload capability, allowing Baud rate generation independent from the timers.

SSCBR is the dual-function Baud Rate Generator/Reload register. Table 11 lists some possible Baud rates against the required reload values and the resulting bit times for a 25MHz CPU clock.

Table 11 : Synchronous Baud rate and reload values

Baud Rate	Bit Time	Reload Value
Reserved use a reload value > 0.	---	0000 _H
5M Baud	200ns	0001 _H
3.3M Baud	303ns	0002 _H
2.5M Baud	400ns	0004 _H
2M Baud	500ns	0005 _H
1M Baud	1μs	000B _H
100K Baud	10μs	007C _H
10K Baud	100μs	04E1 _H
1K Baud	1ms	30D3 _H
190.7 Baud	5.2ms	FFFF _H

XIV - CAN MODULE

The integrated CAN module handles the completely autonomous transmission and reception of CAN frames in accordance with the CAN specification V2.0 part B (active) i.e. the on-chip CAN module can receive and transmit standard frames with 11-bit identifiers as well as extended frames with 29-bit identifiers.

The CAN module provides full CAN functionality on up to 15 message objects. Message object 15 can be configured for basic CAN functionality.

Both modes provide separate masks for acceptance filtering, allowing a number of identifiers in full CAN mode to be accepted and disregarding a number of identifiers in basic CAN mode.

All message objects can be updated independent from other objects and are equipped for the maximum message length of 8 Byte.

The bit timing is derived from the XCLK and is programmable up to a data rate of 1M Baud. The CAN module uses two pins to interface to a bus transceiver.

XV - WATCHDOG TIMER

The Watchdog Timer is a fail-safe mechanism which prevents the microcontroller from malfunctioning for long periods of time. The Watchdog Timer is always enabled after a reset of the chip and can only be disabled in the time interval until the EINIT (end of initialization) instruction has been executed. Therefore, the chip start-up procedure is always monitored. The software must be designed to service the watchdog timer before it overflows. If, due to hardware or software related failures, the software fails to do so, the watchdog timer overflows and generates an internal hardware reset. It pulls the RSTOUT pin low in order to allow external hardware components to be reset.

The Watchdog Timer is 16-bit, clocked with the system clock divided by 2 or 128. The high Byte of the watchdog timer register can be set to a pre-specified reload value (stored in WDTREL). Each time it is serviced by the application software, the high Byte of the watchdog timer is reloaded. *For security, rewrite WDTCON each time before the watchdog timer is serviced*

Table 12 : Watchdog time range for 25MHz CPU clock

Reload value in WDTREL	Prescaler for f_{CPU}	
	2 (WDTIN = '0')	128 (WDTIN = '1')
FF _H	20.48 μ s	1.31ms
00 _H	5.24ms	336ms

XVI - INSTRUCTION SET SUMMARY

The table below lists the instructions of the ST10C167. The various addressing modes, instruction operation, parameters for conditional

execution of instructions, opcodes and a detailed description of each instruction can be found in the "ST10 Family Programming Manual".

Table 13 : Instruction set summary

Mnemonic	Description	Bytes
ADD(B)	Add Word (Byte) operands	2 / 4
ADDC(B)	Add Word (Byte) operands with Carry	2 / 4
SUB(B)	Subtract Word (Byte) operands	2 / 4
SUBC(B)	Subtract Word (Byte) operands with Carry	2 / 4
MUL(U)	(Un)Signed multiply direct GPR by direct GPR (16-16-bit)	2
DIV(U)	(Un)Signed divide register MDL by direct GPR (16-/16-bit)	2
DIVL(U)	(Un)Signed long divide register MD by direct GPR (32-/16-bit)	2
CPL(B)	Complement direct Word (Byte) GPR	2
NEG(B)	Negate direct Word (Byte) GPR	2
AND(B)	Bitwise AND, (Word/Byte operands)	2 / 4
OR(B)	Bitwise OR, (Word/Byte operands)	2 / 4
XOR(B)	Bitwise XOR, (Word/Byte operands)	2 / 4
BCLR	Clear direct bit	2
BSET	Set direct bit	2
BMOV(N)	Move (negated) direct bit to direct bit	4
BAND, BOR, BXOR	AND/OR/XOR direct bit with direct bit	4
BCMP	Compare direct bit to direct bit	4
BFLDH/L	Bitwise modify masked high/low byte of bit-addressable direct Word memory with immediate data	4
CMP(B)	Compare Word (Byte) operands	2 / 4
CMPD1/2	Compare Word data to GPR and decrement GPR by 1/2	2 / 4
CMPI1/2	Compare Word data to GPR and increment GPR by 1/2	2 / 4
PRIOR	Determine number of shift cycles to normalize direct Word GPR and store result in direct Word GPR	2
SHL / SHR	Shift left/right direct Word GPR	2
ROL / ROR	Rotate left/right direct Word GPR	2
ASHR	Arithmetic (sign bit) shift right direct Word GPR	2
MOV(B)	Move Word (Byte) data	2 / 4
MOVBS	Move Byte operand to Word operand with sign extension	2 / 4
MOVBSZ	Move Byte operand to Word operand. with zero extension	2 / 4
JMPA, JMPI, JMPR	Jump absolute/indirect/relative if condition is met	4
JMPS	Jump absolute to a code segment	4
J(N)B	Jump relative if direct bit is (not) set	4
JBC	Jump relative and clear bit if direct bit is set	4

XVI - INSTRUCTION SET SUMMARY (continued)

Table 13 : Instruction set summary (continued)

Mnemonic	Description	Bytes
JNBS	Jump relative and set bit if direct bit is not set	4
CALLA, CALLI, CALLR	Call absolute/indirect/relative subroutine if condition is met	4
CALLS	Call absolute subroutine in any code segment	4
PCALL	Push direct Word register onto system stack & call absolute subroutine	4
TRAP	Call interrupt service routine via immediate trap number	2
PUSH, POP	Push/pop direct Word register onto/from system stack	2
SCXT	Push direct Word register onto system stack and update register with Word operand	4
RET	Return from intra-segment subroutine	2
RETS	Return from inter-segment subroutine	2
RETP	Return from intra-segment subroutine and pop direct Word register from system stack	2
RETI	Return from interrupt service subroutine	2
SRST	Software Reset	4
IDLE	Enter Idle Mode	4
PWRDN	Enter Power Down Mode (assumes $\overline{\text{NMI}}$ -pin low)	4
SRVWDT	Service Watchdog Timer	4
DISWDT	Disable Watchdog Timer	4
EINIT	Signify End-of-Initialization on RSTOUT-pin	4
ATOMIC	Begin ATOMIC sequence	2
EXTR	Begin EXTended Register sequence	2
EXTP(R)	Begin EXTended Page (and Register) sequence	2 / 4
EXTS(R)	Begin EXTended Segment (and Register) sequence	2 / 4
NOP	Null operation	2

XVII - SYSTEM RESET

The internal system reset function is invoked either by asserting a hardware reset signal on pin $\overline{\text{RSTIN}}$ (Hardware Reset Input), by the execution of the SRST instruction (Software Reset) or by an overflow of the watchdog timer. Whenever one of these conditions occurs, the microcontroller is reset into its predefined default state. The following type of reset are implemented on the ST10C167:

Asynchronous hardware reset

Asynchronous reset does not require a stabilized clock signal on XTAL1, as it is not internally resynchronized. It immediately resets the microcontroller into its default reset state.

This asynchronous reset is required upon power-up of the chip and may be used during catastrophic situations. The rising edge of the RSTIN pin is internally resynchronized before exiting the reset condition. Therefore, only the entry of this hardware reset is asynchronous.

Synchronous hardware reset (warm reset)

A warm synchronous hardware reset is triggered when the reset input signal $\overline{\text{RSTIN}}$ is latched low and RPD (Pin 84) is high. The I/Os are immediately (asynchronously) set in high impedance, $\overline{\text{RSTOUT}}$ is driven low. After negation of $\overline{\text{RSTIN}}$ is detected, a short transition period elapses, during which pending internal hold states are cancelled and any current internal access cycles are completed, external bus cycles are aborted.

Then, the internal reset sequence starts for 1024 TCL (512 CPU clock cycles). During this reset sequence, if bit BDRSTEN was previously set by software (bit 5 in SYSCON register), $\overline{\text{RSTIN}}$ pin is driven low and internal reset signal is asserted to reset the microcontroller in its default state. Note that after all reset sequences, bit BDRSTEN is cleared.

After the reset sequence has been completed, the $\overline{\text{RSTIN}}$ input is sampled. If the reset input signal is

active at that time the internal reset condition is prolonged until $\overline{\text{RSTIN}}$ becomes inactive.

Software reset

The reset sequence can be triggered at any time by the protected instruction SRST (software reset). This instruction can be executed deliberately within a program, e.g. to leave bootstrap loader mode, or on a hardware trap that reveals a system failure. As for a synchronous hardware reset, the reset sequence lasts 1024 TCL (512 CPU clock cycles), and drives the $\overline{\text{RSTIN}}$ pin low.

Watchdog timer reset

When the watchdog timer is not disabled during the initialization or serviced regularly during program execution it will overflow and trigger the reset sequence.

Unlike hardware and software resets, the watchdog reset completes a running external bus cycle if this bus cycle either does not use $\overline{\text{READY}}$, or if $\overline{\text{READY}}$ is sampled active (low) after the programmed waitstates.

When $\overline{\text{READY}}$ is sampled inactive (high) after the programmed waitstates the running external bus cycle is aborted. The internal reset sequence is then started. The watchdog reset cannot occur while the ST10C167 is in bootstrap loader mode.

Bidirectional reset

This feature is enabled by bit 3 of the SYSCON register. The bidirectional reset makes the watchdog timer reset and software reset externally visible. It is active for the duration of an internal reset sequences caused by a watchdog timer reset and software reset.

This means that the bidirectional reset transforms an internal watchdog timer reset or software reset into an external hardware reset with a minimum duration of 1024 TCL. The consequence is that during a watchdog timer reset or software reset, the behavior of the ST10C167 is equal to an external hardware reset.

XVIII - POWER REDUCTION MODES

Two different power reduction modes with different levels of power reduction can be entered under software control.

In **Idle mode** the CPU is stopped, while the peripherals continue their operation. Idle mode can be terminated by any reset or interrupt request.

In **Power Down mode** both the CPU and the peripherals are stopped. Power Down mode can be configured by software in order to be terminated only by a hardware reset or by an external interrupt source on fast external interrupt pins. There are two different operating Power Down modes:

- **Protected power down mode:** selected by setting bit PWDCFG in the SYSCON register to '0'. This mode can be used in conjunction with an external power failure signal which pulls the $\overline{\text{NMI}}$ pin low when a power failure is imminent. The microcontroller enters the $\overline{\text{NMI}}$ trap routine and saves the internal state into RAM. The trap routine then sets a flag or writes a bit pattern into specific RAM locations, and executes the PWRDN instruction. If the $\overline{\text{NMI}}$ pin is still low at this time, Power Down mode will be entered, if not program execution continues. During power

down the voltage at the V_{CC} pins can be lowered to 2.5 V and the contents of the internal RAM will still be preserved.

- **Interruptible power down mode:** this mode is selected by setting bit PWDCFG in the SYSCON register. The CPU and peripheral clocks are frozen, and the oscillator and PLL are stopped. To exit power down mode with an external interrupt, an EXxIN ($x = 7...0$) pin has to be asserted for at least 40ns. This signal enables the internal oscillator and PLL circuitry, and turns on the weak pull-down. If the Interrupt was enabled before entering power down mode, the device executes the interrupt service routine, and then resumes execution after the PWRDN instruction. If the interrupt was disabled, the device executes the instruction following PWRDN instruction, and the Interrupt Request Flag remains set until it is cleared by software.

All external bus actions are completed before Idle or Power Down mode is entered. However, Idle or Power Down mode is not entered if READY is enabled, but has not been activated during the last bus access.

XIX - SPECIAL FUNCTION REGISTER OVERVIEW

Table 14 lists all SFRs which are implemented in the ST10C167 in alphabetical order.

Bit-addressable SFRs are marked with the letter "b" in column "Name". SFRs within the Extended SFR-Space (ESFRs) are marked with the letter "E" in column "Physical Address".

An SFR can be specified by its individual mnemonic name. Depending on the selected addressing mode, an SFR can be accessed via its physical address (using the Data Page Pointers), or via its short 8-bit address (without using the Data Page Pointers).

Table 14 : Special function registers listed by name

Name	Physical address	8-bit address	Description	Reset value
ADCIC b	FF98h	CCh	A/D Converter End Of Conversion Interrupt Control Register	0000h
ADCON b	FFA0h	D0h	A/D Converter Control Register	0000h
ADDAT	FEA0h	50h	A/D Converter Result Register	0000h
ADDAT2	F0A0h E	50h	A/D Converter 2 Result Register	0000h
ADDRSEL1	FE18h	0Ch	Address Select Register 1	0000h
ADDRSEL2	FE1Ah	0Dh	Address Select Register 2	0000h
ADDRSEL3	FE1Ch	0Eh	Address Select Register 3	0000h
ADDRSEL4	FE1Eh	0Fh	Address Select Register 4	0000h
ADEIC b	FF9Ah	CDh	A/D Converter Overrun Error Interrupt Control Register	0000h
BUSCON0 b	FF0Ch	86h	Bus Configuration Register 0	0XX0h
BUSCON1 b	FF14h	8Ah	Bus Configuration Register 1	0000h
BUSCON2 b	FF16h	8Bh	Bus Configuration Register 2	0000h
BUSCON3 b	FF18h	8Ch	Bus Configuration Register 3	0000h
BUSCON4 b	FF1Ah	8Dh	Bus Configuration Register 4	0000h
CAPREL	FE4Ah	25h	GPT2 Capture/Reload Register	0000h
CC8IC b	FF88h	C4h	EX0IN Interrupt Control Register	0000h
CC0	FE80h	40h	CAPCOM Register 0	0000h
CC0IC b	FF78h	BCh	CAPCOM Register 0 Interrupt Control Register	0000h
CC1	FE82h	41h	CAPCOM Register 1	0000h
CC1IC b	FF7Ah	BDh	CAPCOM Register 1 Interrupt Control Register	0000h
CC2	FE84h	42h	CAPCOM Register 2	0000h
CC2IC b	FF7Ch	BEh	CAPCOM Register 2 Interrupt Control Register	0000h
CC3	FE86h	43h	CAPCOM Register 3	0000h
CC3IC b	FF7Eh	BFh	CAPCOM Register 3 Interrupt Control Register	0000h
CC4	FE88h	44h	CAPCOM Register 4	0000h
CC4IC b	FF80h	C0h	CAPCOM Register 4 Interrupt Control Register	0000h
CC5	FE8Ah	45h	CAPCOM Register 5	0000h
CC5IC b	FF82h	C1h	CAPCOM Register 5 Interrupt Control Register	0000h
CC6	FE8Ch	46h	CAPCOM Register 6	0000h
CC6IC b	FF84h	C2h	CAPCOM Register 6 Interrupt Control Register	0000h
CC7	FE8Eh	47h	CAPCOM Register 7	0000h
CC7IC b	FF86h	C3h	CAPCOM Register 7 Interrupt Control Register	0000h
CC8	FE90h	48h	CAPCOM Register 8	0000h

XIX - SPECIAL FUNCTION REGISTER OVERVIEW (continued)

Table 14 : Special function registers listed by name (continued)

Name	Physical address	8-bit address	Description	Reset value
CC8IC b	FF88h	C4h	CAPCOM Register 8 Interrupt Control Register	0000h
CC9	FE92h	49h	CAPCOM Register 9	0000h
CC9IC b	FF8Ah	C5h	CAPCOM Register 9 Interrupt Control Register	0000h
CC10	FE94h	4Ah	CAPCOM Register 10	0000h
CC10IC b	FF8Ch	C6h	CAPCOM Register 10 Interrupt Control Register	0000h
CC11	FE96h	4Bh	CAPCOM Register 11	0000h
CC11IC b	FF8Eh	C7h	CAPCOM Register 11 Interrupt Control Register	0000h
CC12	FE98h	4Ch	CAPCOM Register 12	0000h
CC12IC b	FF90h	C8h	CAPCOM Register 12 Interrupt Control Register	0000h
CC13	FE9Ah	4Dh	CAPCOM Register 13	0000h
CC13IC b	FF92h	C9h	CAPCOM Register 13 Interrupt Control Register	0000h
CC14	FE9Ch	4Eh	CAPCOM Register 14	0000h
CC14IC b	FF94h	CAh	CAPCOM Register 14 Interrupt Control Register	0000h
CC15	FE9Eh	4Fh	CAPCOM Register 15	0000h
CC15IC b	FF96h	CBh	CAPCOM Register 15 Interrupt Control Register	0000h
CC16	FE60h	30h	CAPCOM Register 16	0000h
CC16IC b	F160h E	B0h	CAPCOM Register 16 Interrupt Control Register	0000h
CC17	FE62h	31h	CAPCOM Register 17	0000h
CC17IC b	F162h E	B1h	CAPCOM Register 17 Interrupt Control Register	0000h
CC18	FE64h	32h	CAPCOM Register 18	0000h
CC18IC b	F164h E	B2h	CAPCOM Register 18 Interrupt Control Register	0000h
CC19	FE66h	33h	CAPCOM Register 19	0000h
CC19IC b	F166h E	B3h	CAPCOM Register 19 Interrupt Control Register	0000h
CC20	FE68h	34h	CAPCOM Register 20	0000h
CC20IC b	F168h E	B4h	CAPCOM Register 20 Interrupt Control Register	0000h
CC21	FE6Ah	35h	CAPCOM Register 21	0000h
CC21IC b	F16Ah E	B5h	CAPCOM Register 21 Interrupt Control Register	0000h
CC22	FE6Ch	36h	CAPCOM Register 22	0000h
CC22IC b	F16Ch E	B6h	CAPCOM Register 22 Interrupt Control Register	0000h
CC23	FE6Eh	37h	CAPCOM Register 23	0000h
CC23IC b	F16Eh E	B7h	CAPCOM Register 23 Interrupt Control Register	0000h
CC24	FE70h	38h	CAPCOM Register 24	0000h
CC24IC b	F170h E	B8h	CAPCOM Register 24 Interrupt Control Register	0000h
CC25	FE72h	39h	CAPCOM Register 25	0000h
CC25IC b	F172h E	B9h	CAPCOM Register 25 Interrupt Control Register	0000h
CC26	FE74h	3Ah	CAPCOM Register 26	0000h
CC26IC b	F174h E	BAh	CAPCOM Register 26 Interrupt Control Register	0000h
CC27	FE76h	3Bh	CAPCOM Register 27	0000h

XIX - SPECIAL FUNCTION REGISTER OVERVIEW (continued)**Table 14** : Special function registers listed by name (continued)

Name	Physical address	8-bit address	Description	Reset value
CC27IC b	F176h E	BBh	CAPCOM Register 27 Interrupt Control Register	0000h
CC28	FE78h	3Ch	CAPCOM Register 28	0000h
CC28IC b	F178h E	BCh	CAPCOM Register 28 Interrupt Control Register	0000h
CC29	FE7Ah	3Dh	CAPCOM Register 29	0000h
CC29IC b	F184h E	C2h	CAPCOM Register 29 Interrupt Control Register	0000h
CC30	FE7Ch	3Eh	CAPCOM Register 30	0000h
CC30IC b	F18Ch E	C6h	CAPCOM Register 30 Interrupt Control Register	0000h
CC31	FE7Eh	3Fh	CAPCOM Register 31	0000h
CC31IC b	F194h E	CAh	CAPCOM Register 31 Interrupt Control Register	0000h
CCM0 b	FF52h	A9h	CAPCOM Mode Control Register 0	0000h
CCM1 b	FF54h	AAh	CAPCOM Mode Control Register 1	0000h
CCM2 b	FF56h	ABh	CAPCOM Mode Control Register 2	0000h
CCM3 b	FF58h	ACH	CAPCOM Mode Control Register 3	0000h
CCM4 b	FF22h	91h	CAPCOM Mode Control Register 4	0000h
CCM5 b	FF24h	92h	CAPCOM Mode Control Register 5	0000h
CCM6 b	FF26h	93h	CAPCOM Mode Control Register 6	0000h
CCM7 b	FF28h	94h	CAPCOM Mode Control Register 7	0000h
CP	FE10h	08h	CPU Context Pointer Register	FC00h
CRIC b	FF6Ah	B5h	GPT2 CAPREL Interrupt Control Register	0000h
CSP	FE08h	04h	CPU Code Segment Pointer Register (read only)	0000h
DP0L b	F100h E	80h	P0L Direction Control Register	00h
DP0H b	F102h E	81h	P0h Direction Control Register	00h
DP1L b	F104h E	82h	P1L Direction Control Register	00h
DP1H b	F106h E	83h	P1h Direction Control Register	00h
DP2 b	FFC2h	E1h	Port 2 Direction Control Register	0000h
DP3 b	FFC6h	E3h	Port 3 Direction Control Register	0000h
DP4 b	FFCAh	E5h	Port 4 Direction Control Register	00h
DP6 b	FFCEh	E7h	Port 6 Direction Control Register	00h
DP7 b	FFD2h	E9h	Port 7 Direction Control Register	00h
DP8 b	FFD6h	EBh	Port 8 Direction Control Register	00h
DPP0	FE00h	00h	CPU Data Page Pointer 0 Register (10 bit)	0000h
DPP1	FE02h	01h	CPU Data Page Pointer 1 Register (10 bit)	0001h
DPP2	FE04h	02h	CPU Data Page Pointer 2 Register (10 bit)	0002h
DPP3	FE06h	03h	CPU Data Page Pointer 3 Register (10 bit)	0003h
EXICON b	F1C0h E	E0h	External Interrupt Control Register	0000h
IDCHIP	F07Ch E	3Eh	Device Identifier Register	0A7h ¹
IDMANUF	F07Eh E	3Fh	Manufacturer Identifier Register	0020h ¹
IDMEM	F07Ah E	3Dh	On-chip Memory Identifier Register	3020h ¹

XIX - SPECIAL FUNCTION REGISTER OVERVIEW (continued)

Table 14 : Special function registers listed by name (continued)

Name	Physical address	8-bit address	Description	Reset value
IDPROG	F078h E	3Ch	Programming Voltage Identifier Register	9A40h ¹
MDC b	FF0Eh	87h	CPU Multiply Divide Control Register	0000h
MDH	FE0Ch	06h	CPU Multiply Divide Register – High Word	0000h
MDL	FE0Eh	07h	CPU Multiply Divide Register – Low Word	0000h
ODP2 b	F1C2h E	E1h	Port 2 Open Drain Control Register	0000h
ODP3 b	F1C6h E	E3h	Port 3 Open Drain Control Register	0000h
ODP6 b	F1CEh E	E7h	Port 6 Open Drain Control Register	00h
ODP7 b	F1D2h E	E9h	Port 7 Open Drain Control Register	00h
ODP8 b	F1D6h E	EBh	Port 8 Open Drain Control Register	00h
ONES	FF1Eh	8Fh	Constant Value 1's Register (read only)	FFFFh
P0L b	FF00h	80h	Port 0 Low Register (Lower half of Port0)	00h
P0H b	FF02h	81h	Port 0 High Register (Upper half of Port0)	00h
P1L b	FF04h	82h	Port 1 Low Register (Lower half of Port1)	00h
P1H b	FF06h	83h	Port 1 High Register (Upper half of Port1)	00h
P2 b	FFC0h	E0h	Port 2 Register	0000h
P3 b	FFC4h	E2h	Port 3 Register	0000h
P4 b	FFC8h	E4h	Port 4 Register (8 bit)	00h
P5 b	FFA2h	D1h	Port 5 Register (read only)	XXXXh
P6 b	FFCCh	E6h	Port 6 Register (8 bit)	00h
P7 b	FFD0h	E8h	Port 7 Register (8 bit)	00h
P8 b	FFD4h	EAh	Port 8 Register (8 bit)	00h
PECC0	FEC0h	60h	PEC Channel 0 Control Register	0000h
PECC1	FEC2h	61h	PEC Channel 1 Control Register	0000h
PECC2	FEC4h	62h	PEC Channel 2 Control Register	0000h
PECC3	FEC6h	63h	PEC Channel 3 Control Register	0000h
PECC4	FEC8h	64h	PEC Channel 4 Control Register	0000h
PECC5	FECAh	65h	PEC Channel 5 Control Register	0000h
PECC6	FECCh	66h	PEC Channel 6 Control Register	0000h
PECC7	FECeh	67h	PEC Channel 7 Control Register	0000h
PICON	F1C4h E	E2h	Port Input Threshold Control Register	0000h
PP0	F038h E	1Ch	PWM Module Period Register 0	0000h
PP1	F03Ah E	1Dh	PWM Module Period Register 1	0000h
PP2	F03Ch E	1Eh	PWM Module Period Register 2	0000h
PP3	F03Eh E	1Fh	PWM Module Period Register 3	0000h
PSW b	FF10h	88h	CPU Program Status Word	0000h
PT0	F030h E	18h	PWM Module Up/Down Counter 0	0000h
PT1	F032h E	19h	PWM Module Up/Down Counter 1	0000h

XIX - SPECIAL FUNCTION REGISTER OVERVIEW (continued)**Table 14** : Special function registers listed by name (continued)

Name	Physical address	8-bit address	Description	Reset value
PT2	F034h E	1Ah	PWM Module Up/Down Counter 2	0000h
PT3	F036h E	1Bh	PWM Module Up/Down Counter 3	0000h
PW0	FE30h	18h	PWM Module Pulse Width Register 0	0000h
PW1	FE32h	19h	PWM Module Pulse Width Register 1	0000h
PW2	FE34h	1Ah	PWM Module Pulse Width Register 2	0000h
PW3	FE36h	1Bh	PWM Module Pulse Width Register 3	0000h
PWMCON0b	FF30h	98h	PWM Module Control Register 0	0000h
PWMCON1b	FF32h	99h	PWM Module Control Register 1	0000h
PWMIC b	F17Eh E	BFh	PWM Module Interrupt Control Register	0000h
RP0H b	F108h E	84h	System Start-up Configuration Register (read only)	XXh
S0BG	FEB4h	5Ah	Serial Channel 0 Baud Rate Generator Reload Register	0000h
S0CON b	FFB0h	D8h	Serial Channel 0 Control Register	0000h
S0EIC b	FF70h	B8h	Serial Channel 0 Error Interrupt Control Register	0000h
S0RBUF	FEB2h	59h	Serial Channel 0 Receive Buffer Register (read only)	XXh
S0RIC b	FF6Eh	B7h	Serial Channel 0 Receive Interrupt Control Register	0000h
S0TBIC b	F19Ch E	CEh	Serial Channel 0 Transmit Buffer Interrupt Control Register	0000h
S0TBUF	FEB0h	58h	Serial Channel 0 Transmit Buffer Register (write only)	00h
S0TIC b	FF6Ch	B6h	Serial Channel 0 Transmit Interrupt Control Register	0000h
SP	FE12h	09h	CPU System Stack Pointer Register	FC00h
SSCBR	F0B4h E	5Ah	SSC Baud rate Register	0000h
SSCCON b	FFB2h	D9h	SSC Control Register	0000h
SSCEIC b	FF76h	BBh	SSC Error Interrupt Control Register	0000h
SSCRB	F0B2h E	59h	SSC Receive Buffer (read only)	XXXh
SSCRIC b	FF74h	BAh	SSC Receive Interrupt Control Register	0000h
SSCTB	F0B0h E	58h	SSC Transmit Buffer (write only)	0000h
SSCTIC b	FF72h	B9h	SSC Transmit Interrupt Control Register	0000h
STKOV	FE14h	0Ah	CPU Stack Overflow Pointer Register	FA00h
STKUN	FE16h	0Bh	CPU Stack Underflow Pointer Register	FC00h
SYSCON b	FF12h	89h	CPU System Configuration Register	0xx0h ²
T0	FE50h	28h	CAPCOM Timer 0 Register	0000h
T01CON b	FF50h	A8h	CAPCOM Timer 0 and Timer 1 Control Register	0000h
T0IC b	FF9Ch	CEh	CAPCOM Timer 0 Interrupt Control Register	0000h
T0REL	FE54h	2Ah	CAPCOM Timer 0 Reload Register	0000h
T1	FE52h	29h	CAPCOM Timer 1 Register	0000h
T1IC b	FF9Eh	CFh	CAPCOM Timer 1 Interrupt Control Register	0000h
T1REL	FE56h	2Bh	CAPCOM Timer 1 Reload Register	0000h
T2	FE40h	20h	GPT1 Timer 2 Register	0000h

XIX - SPECIAL FUNCTION REGISTER OVERVIEW (continued)

Table 14 : Special function registers listed by name (continued)

Name	Physical address	8-bit address	Description	Reset value
T2CON b	FF40h	A0h	GPT1 Timer 2 Control Register	0000h
T2IC b	FF60h	B0h	GPT1 Timer 2 Interrupt Control Register	0000h
T3	FE42h	21h	GPT1 Timer 3 Register	0000h
T3CON b	FF42h	A1h	GPT1 Timer 3 Control Register	0000h
T3IC b	FF62h	B1h	GPT1 Timer 3 Interrupt Control Register	0000h
T4	FE44h	22h	GPT1 Timer 4 Register	0000h
T4CON b	FF44h	A2h	GPT1 Timer 4 Control Register	0000h
T4IC b	FF64h	B2h	GPT1 Timer 4 Interrupt Control Register	0000h
T5	FE46h	23h	GPT2 Timer 5 Register	0000h
T5CON b	FF46h	A3h	GPT2 Timer 5 Control Register	0000h
T5IC b	FF66h	B3h	GPT2 Timer 5 Interrupt Control Register	0000h
T6	FE48h	24h	GPT2 Timer 6 Register	0000h
T6CON b	FF48h	A4h	GPT2 Timer 6 Control Register	0000h
T6IC b	FF68h	B4h	GPT2 Timer 6 Interrupt Control Register	0000h
T7	F050h E	28h	CAPCOM Timer 7 Register	0000h
T78CON b	FF20h	90h	CAPCOM Timer 7 and 8 Control Register	0000h
T7IC b	F17Ah E	BEh	CAPCOM Timer 7 Interrupt Control Register	0000h
T7REL	F054h E	2Ah	CAPCOM Timer 7 Reload Register	0000h
T8	F052h E	29h	CAPCOM Timer 8 Register	0000h
T8IC b	F17Ch E	BFh	CAPCOM Timer 8 Interrupt Control Register	0000h
T8REL	F056h E	2Bh	CAPCOM Timer 8 Reload Register	0000h
TFR b	FFACh	D6h	Trap Flag Register	0000h
WDT	FEAEh	57h	Watchdog Timer Register (read only)	0000h
WDTCN	FFAEh	D7h	Watchdog Timer Control Register	000xh ³
XP0IC b	F186h E	C3h	CAN Module Interrupt Control Register	0000h ⁴
XP1IC b	F18Eh E	C7h	X-Peripheral 1 Interrupt Control Register	0000h ⁴
XP2IC b	F196h E	CBh	X-Peripheral 2 Interrupt Control Register	0000h ⁴
XP3IC b	F19Eh E	CFh	PLL Unlock Interrupt Control Register	0000h ⁴
ZEROS b	FF1Ch	8Eh	Constant Value 0's Register (read only)	0000h

Notes 1. The value depends on the silicon revision and is described in the chapter XIX.1.

2. The system configuration is selected during reset.

3. Bit WDTR indicates a watchdog timer triggered reset.

4. The XPnIC Interrupt Control Registers control the interrupt requests from integrated X-Bus peripherals. Nodes where no X-Peripherals are connected may be used to generate software controlled interrupt requests by setting the respective XPnIR bit.

XIX - SPECIAL FUNCTION REGISTER OVERVIEW (continued)**XIX.1 - Identification Registers**

The ST10C167 has four Identification registers, mapped in ESFR space. These registers contain:

- a manufacturer identifier,
- a chip identifier, with its revision,
- a internal memory and size identifier,
- programming voltage description.

IDMANUF (F07Eh / 3Fh) ESFR

Description

IDMANUF : Manufacturer Identifier - 0400h: STmicroelectronics Manufacturer (JTAG world-wide normalisation).

IDCHIP (F07Ch / 3Eh) ESFR

Description

IDCHIP: Device Identifier - 0A72h for ST10C167.

IDMEM (F07Ah / 3Dh) ESFR

Description

IDMEM: 1008h for ST10C167 (MCU with ROM).

IDPROG (F078h / 3Ch) ESFR

Description

IDPROG: 0000h for ST10C167 (MCU with ROM).

XX - ELECTRICAL CHARACTERISTICS**XX.1 - Absolute maximum ratings**

Symbol	Parameter	Value	Unit
V_{SS}	Voltage on V_{DD} pins with respect to ground	-0.5, +6.5	V
V_{SS}	Voltage on any pin with respect to ground	-0.3 to V_{DD} +0.3	V
	Input current on any pin during overload condition	-10, +10	mA
	Absolute sum of all input currents during overload condition	100	mA
P_{tot}	Power Dissipation	1.5	W
T_{amb}	Ambient Temperature under bias	-40, +125	°C
T_{stg}	Storage Temperature	-65, +150	°C

Note Stresses above those listed under “Absolute Maximum Ratings” may cause permanent damage to the device. This is a stress rating only and functional operation of the device at these or any other conditions above those indicated in the operational sections of this specification is not implied. Exposure to absolute maximum rating conditions for extended periods may affect device reliability. During overload conditions ($V_{IN} > V_{DD}$ or $V_{IN} < V_{SS}$) the voltage on pins with respect to ground (V_{SS}) must not exceed the values defined by the Absolute Maximum Ratings.

XX.2 - Parameter interpretation

The parameters listed in the following tables represent the characteristics of the ST10C167 and its demands on the system. Where the ST10C167 logic provides signals with their respective timing characteristics, the symbol “CC”

for Controller Characteristics is included in the “Symbol” column.

Where the external system must provide signals with their respective timing characteristics to the ST10C167, the symbol “SR” for System Requirement is included in the “Symbol” column.

XX - ELECTRICAL CHARACTERISTICS (continued)**XX.3 - DC characteristics**

$V_{DD} = 5V \pm 10\%$, $V_{SS} = 0V$, $f_{CPU} = 25MHz$, Reset active, $T_A = -40$ to $+125^\circ C$, unless otherwise specified.

Table 15 : DC characteristics

Symbol	Parameter	Test Conditions	Minimum	Maximum	Unit
V_{IL} SR	Input low voltage	–	– 0.5	$0.2 V_{DD} - 0.1$	V
V_{ILS} SR	Input low voltage (special threshold)	–	– 0.5	2.0	V
V_{IH} SR	Input high voltage (all except \overline{RSTIN} and XTAL1)	–	$0.2 V_{DD} + 0.9$	$V_{DD} + 0.5$	V
V_{IH1} SR	Input high voltage \overline{RSTIN}	–	$0.6 V_{DD}$	$V_{DD} + 0.5$	V
V_{IH2} SR	Input high voltage XTAL1	–	$0.7 V_{DD}$	$V_{DD} + 0.5$	V
V_{IHS} SR	Input high voltage (Special Threshold)	–	$0.8 V_{DD} - 0.2$	$V_{DD} + 0.5$	V
HYS	Input Hysteresis (Special Threshold)	–	400	–	mV
V_{OL} CC	Output low voltage (Port0, Port1, Port 4, ALE, RD, WR, BHE, CLKOUT, \overline{RSTOUT})	$I_{OL} = 2.4$ mA	–	0.45	V
V_{OL1} CC	Output low voltage (all other outputs)	$I_{OL1} = 1.6$ mA	–	0.45	V
V_{OH} CC	Output high voltage (Port0, Port1, Port 4, ALE, RD, WR, BHE, CLKOUT, \overline{RSTOUT})	$I_{OH} = -500$ μA $I_{OH} = -2.4$ mA	$0.9 V_{DD}$ 2.4	–	V
V_{OH1} CC	Output high voltage ¹ (all other outputs)	$I_{OH} = -250$ μA $I_{OH} = -1.6$ mA	$0.9 V_{DD}$ 2.4	–	V V
I_{OZ1} CC	Input leakage current (Port 5)	$0 V < V_{IN} < V_{DD}$	–	± 0.5	μA
I_{OZ2} CC	Input leakage current (all other)	$0 V < V_{IN} < V_{DD}$	–	± 1	μA
I_{OV} SR	Overload current	⁵ ⁸	–	± 5	mA
R_{RST} CC	\overline{RSTIN} pull-up resistor ⁵	–	50	250	k Ω
I_{RWH} ²	Read/Write inactive current ⁴	$V_{OUT} = 2.4$ V	–	-40	μA
I_{RWL} ³	Read/Write active current ⁴	$V_{OUT} = V_{OLmax}$	-500	–	μA
I_{ALEL} ²	ALE inactive current ⁴	$V_{OUT} = V_{OLmax}$	40	–	μA
I_{ALEH} ³	ALE active current ⁴	$V_{OUT} = 2.4$ V	–	500	μA
I_{P6H} ²	Port 6 inactive current ⁴	$V_{OUT} = 2.4$ V	–	-40	μA
I_{P6L} ³	Port 6 active current ⁴	$V_{OUT} = V_{OL1max}$	-500	–	μA
I_{P0H} ²	Port0 configuration current ⁴	$V_{IN} = V_{IHmin}$	–	-10	μA
I_{P0L} ³		$V_{IN} = V_{ILmax}$	-100	–	μA
I_{IL} CC	XTAL1 input current	$0 V < V_{IN} < V_{DD}$	–	± 20	μA
C_{IO} CC	Pin capacitance ⁵ (digital inputs/outputs)	$f = 1$ MHz $T_A = 25^\circ C$	–	10	pF
I_{CC}	Power supply current	$\overline{RSTIN} = V_{IH1}$ f_{CPU} in [MHz] ⁶	$20 + 6 * f_{CPU}$	$20 + 7 * f_{CPU}$	mA
I_{ID}	Idle mode supply current	$\overline{RSTIN} = V_{IH1}$ f_{CPU} in [MHz] ⁶	–	$20 + 3 * f_{CPU}$	mA
I_{PD}	Power-down mode supply current	$V_{DD} = 5.5$ V ⁷	100	400	μA

XX - ELECTRICAL CHARACTERISTICS (continued)

- Notes
1. This specification is not valid for outputs which are switched to open drain mode. In this case the respective output will float and the voltage results from the external circuitry.
 2. The maximum current may be drawn while the respective signal line remains inactive.
 3. The minimum current must be drawn in order to drive the respective signal line active.
 4. This specification is only valid during Reset, or during Hold- or Adapt-mode. Port 6 pins are only affected if they are used as CSx output and the open drain function is not enabled.
 5. Partially tested, guaranteed by design characterization.
 6. The supply current is a function of the operating frequency. This dependency is illustrated in the figure below. These parameters are tested at V_{DDmax} and 20MHz CPU clock with all outputs disconnected and all inputs at V_{IL} or V_{IH} .
 7. This parameter is tested including leakage currents. All inputs (including pins configured as inputs) at 0V to 0.1V or at $V_{DD} - 0.1V$ to V_{DD} . $V_{REF} = 0V$, all outputs (including pins configured as outputs) disconnected.
 8. Overload conditions occur if the standard operating conditions are exceeded, i.e. the voltage on any pin exceeds the specified range (i.e. $V_{OV} > V_{DD} + 0.5V$ or $V_{OV} < V_{SS} - 0.5V$). The absolute sum of input overload currents on all port pins may not exceed 50mA (see Figure 8).

Figure 8 : Supply/idle current as a function of operating frequency

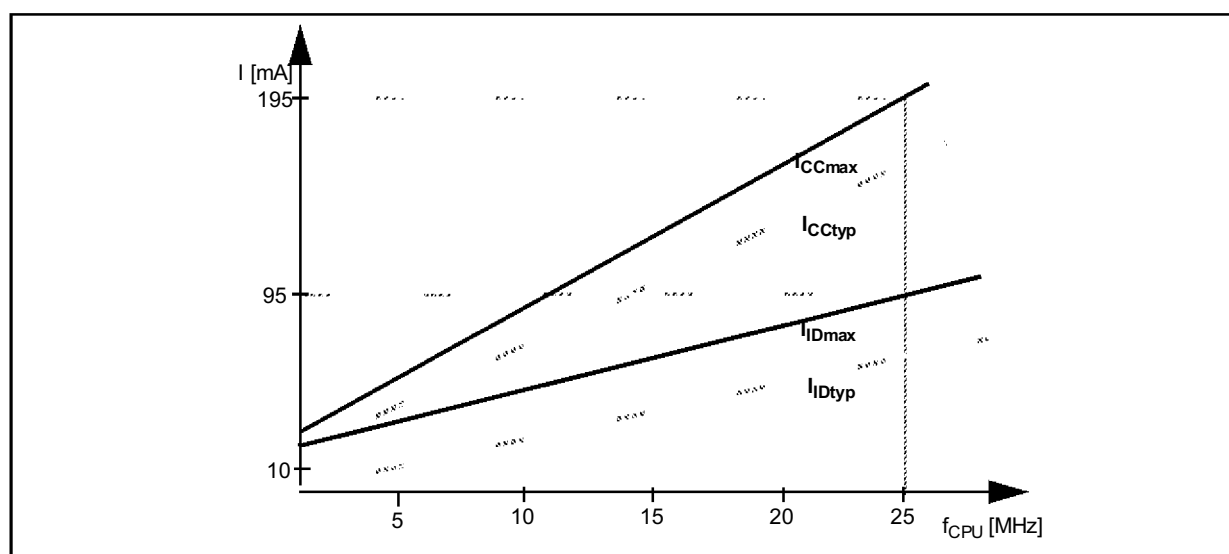

XX.3.1 - A/D converter characteristics

$V_{DD} = 5V \pm 10\%$, $V_{SS} = 0V$, $T_A = -40$ to $+125^\circ C$
 $4.0V \leq V_{AREF} \leq V_{DD} + 0.1V$, $V_{SS} - 0.1V \leq V_{AGND} \leq V_{SS} + 0.2V$ (see Table 16)

Table 16 : A/D converter characteristics

Symbol		Parameter	Test Conditions	Min.	Max.	Unit
V_{AIN}	SR	Analog input voltage range	1	V_{AGND}	V_{AREF}	V
t_S	CC	Sample time	2 4	–	$2 t_{SC}$	
t_C	CC	Conversion time	3 4	–	$14 t_{CC} + t_S + 4TCL$	
TUE	CC	Total unadjusted error	5	–	± 2	LSB
R_{AREF}	SR	Internal resistance of reference voltage source	t_{CC} in [ns] ^{6 7}	–	$t_{CC} / 165 - 0.25$	k Ω
R_{ASRC}	SR	Internal resistance of analog source	t_S in [ns] ^{2 7}	–	$t_S / 330 - 0.25$	k Ω
C_{AIN}	CC	ADC input capacitance	7	–	33	pF

XX - ELECTRICAL CHARACTERISTICS (continued)

- Notes
1. V_{AIN} may exceed V_{AGND} or V_{AREF} up to the absolute maximum ratings. However, the conversion result in these cases will be $X000_H$ or $X3FF_H$, respectively.
 2. During the sample time the input capacitance C_I can be charged/discharged by the external source. The internal resistance of the analog source must allow the capacitance to reach its final voltage level within t_S . After the end of the sample time t_S changes of the analog input voltage have no effect on the conversion result. Values for the sample clock t_{SC} depend on programming and can be taken from the table above.
 3. This parameter includes the sample time t_S , the time for determining the digital result and the time to load the result register with the conversion result. Values for the conversion clock t_{CC} depend on programming and can be taken from the table above.
 4. This parameter is fixed by ADC control logic.
 5. TUE is tested at $V_{AREF} = 5.0V$, $V_{AGND} = 0V$, $V_{CC} = 4.9V$. It is guaranteed by design characterization for all other voltages within the defined voltage range. The specified TUE is guaranteed only if an overload condition (see I_{OV} specification) occurs on maximum of 2 not selected analog input pins and the absolute sum of input overload currents on all analog input pins does not exceed 10mA. During the reset calibration sequence the maximum TUE may be ± 4 LSB.
 6. During the conversion the ADC's capacitance must be repeatedly charged or discharged. The internal resistance of the reference voltage source must allow the capacitance to reach its respective voltage level within t_{CC} . The maximum internal resistance results from the programmed conversion timing.
 7. Partially tested, guaranteed by design characterization.

Sample time and conversion time of the ST10C167's ADC are programmable. The table below should be used to calculate the above timings.

ADCON.15 14 (ADCTC)	Conversion clock t_{CC}	ADCON.13 12 (ADSTC)	Sample clock t_{SC}
00	TCL * 24	00	t_{CC}
01	Reserved, do not use	01	$t_{CC} * 2$
10	TCL * 96	10	$t_{CC} * 4$
11	TCL * 48	11	$t_{CC} * 8$

XX.4 - AC characteristics

Test waveforms

Figure 9 : Input output waveforms

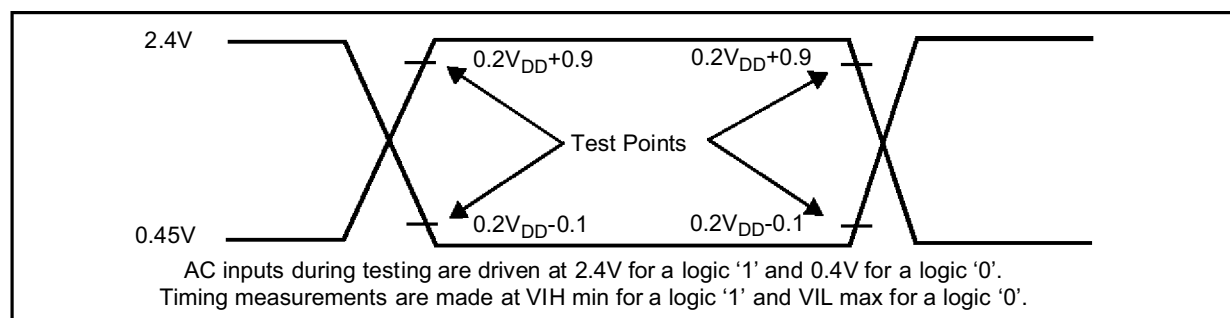
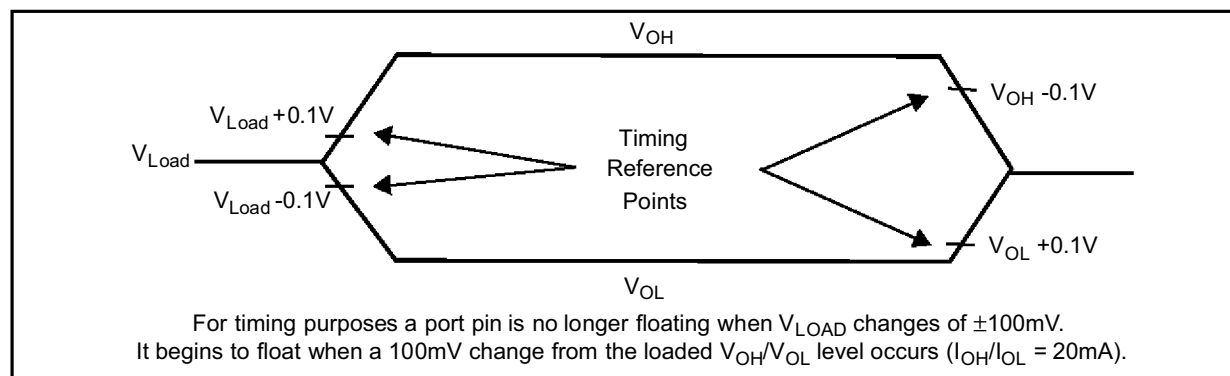

Figure 10 : Float waveforms



XX - ELECTRICAL CHARACTERISTICS (continued)

XX.4.1 - Definition of internal timing

The internal operation of the ST10C167 is controlled by the internal CPU clock f_{CPU} . Both edges of the CPU clock can trigger internal (e.g. pipeline) or external (e.g. bus cycles) operations.

The specification of the external timing (AC Characteristics) therefore depends on the time between two consecutive edges of the CPU clock, called "TCL" periods (see Figure 11).

The CPU clock signal can be generated by different mechanisms. The duration of TCL periods and their variation (and also the derived external timing) depends on the mechanism used

to generate f_{CPU} . This influence must be regarded when calculating the timings for the ST10C167.

The example for PLL operation shown in Figure 11 refers to a PLL factor of 4.

The mechanism used to generate the CPU clock is selected during reset by the logic levels on pins P0.15-13 (P0H.7-5).

XX.4.2 - Clock generation modes

Table 18 shows the association of the combinations of these three bits with the respective clock generation mode.

Figure 11 : Generation mechanisms for the CPU clock

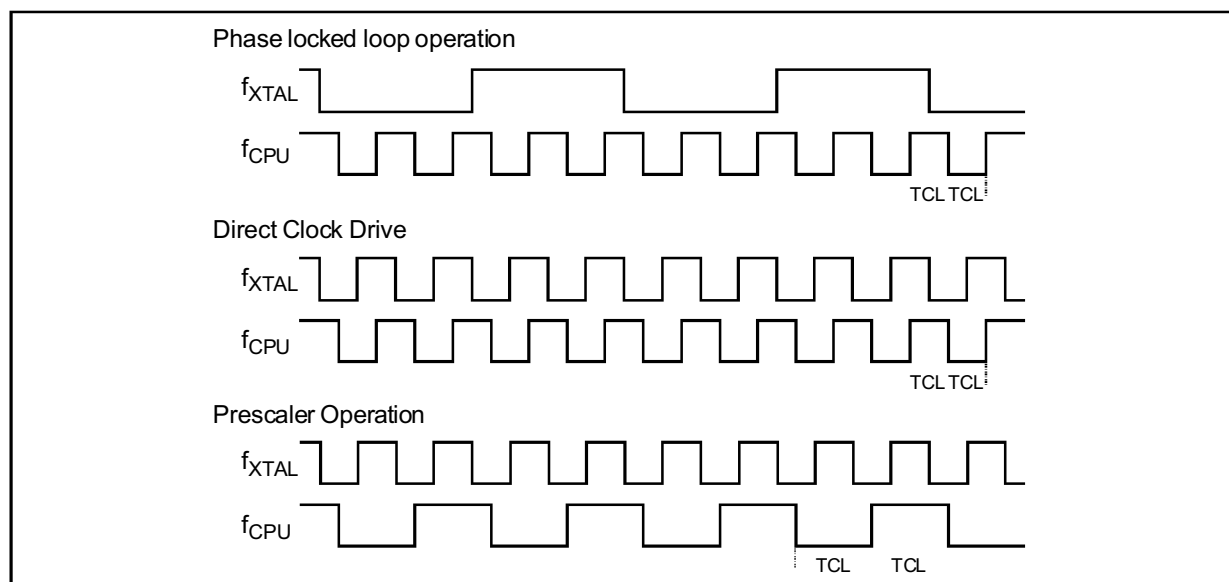

Table 17 : CPU Frequency Generation

P0.15-13 (P0H.7-5)	CPU Frequency $f_{CPU} = f_{XTAL} \times F$	External Clock Input Range ¹	Notes
1 1 1	$F_{XTAL} \times 4$	2.5 to 6.25MHz	Default configuration
1 1 0	$F_{XTAL} \times 3$	3.33 to 8.33MHz	
1 0 1	$F_{XTAL} \times 2$	5 to 12.5MHz	
1 0 0	$F_{XTAL} \times 5$	2 to 5MHz	
0 1 1	$F_{XTAL} \times 1$	1 to 25MHz	Direct drive ²
0 1 0	$F_{XTAL} \times 1.5$	6.66 to 16.6MHz	
0 0 1	$F_{XTAL} / 2$	2 to 50MHz	CPU clock via prescaler
0 0 0	$F_{XTAL} \times 2.5$	4 to 10MHz	

Notes 1. The external clock input range refers to a CPU clock range of 10...25MHz.

2. The maximum frequency depends on the duty cycle of the external clock signal.

XX - ELECTRICAL CHARACTERISTICS (continued)**XX.4.3 - Prescaler operation**

When pins P0.15-13 (POH.7-5) equal '001' during reset the CPU clock is derived from the internal oscillator (input clock signal) by a 2:1 prescaler.

The frequency of f_{CPU} is half the frequency of f_{XTAL} and the high and low time of f_{CPU} (i.e. the duration of an individual TCL) is defined by the period of the input clock f_{XTAL} .

The timings listed in the AC Characteristics that refer to TCLs, therefore, can be calculated using the period of f_{XTAL} for any TCL.

Note that if the bit OWDDIS in SYSCON register is cleared, the PLL is running on its free-running frequency and delivers the clock signal for the Oscillator Watchdog. If bit OWDDIS is set, then the PLL is switched off.

XX.4.4 - Direct drive

When pins P0.15-13 (POH.7-5) equal '011' during reset the on-chip phase locked loop is disabled and the CPU clock is directly driven from the internal oscillator with the input clock signal.

The frequency of f_{CPU} directly follows the frequency of f_{XTAL} so the high and low time of f_{CPU} (i.e. the duration of an individual TCL) is defined by the duty cycle of the input clock f_{XTAL} .

The timings listed below that refer to TCL therefore must be calculated using the minimum TCL that is possible under the respective circumstances. This minimum value can be calculated by the following formula:

$$TCL_{min} = 1/f_{XTAL} * DC_{min}$$

DC = duty cycle

For two consecutive TCLs the deviation caused by the duty cycle of f_{XTAL} is compensated so the duration of 2TCL is always $1/f_{XTAL}$. The minimum value TCL_{min} therefore has to be used only once for timings that require an odd number of TCLs (1,3,...). Timings that require an even number of TCLs (2,4,...) may use the formula:

$$2TCL = 1/f_{XTAL}$$

Note The address float timings in Multiplexed bus mode (t_{11} and t_{45}) use the maximum duration of TCL ($TCL_{max} = 1/f_{XTAL} * DC_{max}$) instead of TCL_{min} .

Note that if the bit OWDDIS in SYSCON register is cleared, the PLL is running on its free-running frequency and delivers the clock signal for the Oscillator Watchdog. If bit OWDDIS is set, then the PLL is switched off.

XX.4.5 - Oscillator watchdog (OWD)

When the clock option selected is direct drive or direct drive with prescaler, in order to provide a fail safe mechanism in case of a loss of the external clock, an oscillator watchdog is implemented as an additional functionality of the PLL circuitry. This oscillator watchdog operates as follows :

After a reset, the Oscillator Watchdog is enabled by default. To disable the OWD, the bit OWDDIS (bit 4 of SYSCON register) must be set.

When the OWD is enabled, the PLL is running on its free-running frequency, and increment the Oscillator Watchdog counter. On each transition of XTAL1 pin, the Oscillator Watchdog is cleared. If an external clock failure occurs, then the Oscillator Watchdog counter overflows (after 16 PLL clock cycles).

The CPU clock signal will be switched to the PLL free-running clock signal, and the Oscillator Watchdog Interrupt Request (XP3INT) is flagged. The CPU clock will not switch back to the external clock even if a valid external clock exists on XTAL1 pin. Only a hardware reset can switch the CPU clock source back to direct clock input.

When the OWD is disabled, the CPU clock is always fed from the oscillator input and the PLL is switched off to decrease power supply current.

XX.4.6 - Phase locked loop

For all other combinations of pins P0.15-13 (POH.7-5) during reset the on-chip phase locked loop is enabled and provides the CPU clock (see table above). The PLL multiplies the input frequency by the factor F which is selected via the combination of pins P0.15-13 (i.e. $f_{CPU} = f_{XTAL} * F$). With every F'th transition of f_{XTAL} the PLL circuit synchronizes the CPU clock to the input clock. This synchronization is done smoothly, i.e. the CPU clock frequency does not change abruptly.

Due to this adaptation to the input clock the frequency of f_{CPU} is constantly adjusted so it is locked to f_{XTAL} . The slight variation causes a jitter of f_{CPU} which also effects the duration of individual TCLs.

The timings listed in the AC Characteristics that refer to TCL therefore must be calculated using the minimum TCL that is possible under the respective circumstances.

XX - ELECTRICAL CHARACTERISTICS (continued)

The real minimum value for TCL depends on the jitter of the PLL. The PLL tunes F_{CPU} to keep it locked on F_{XTAL} . The relative deviation of TCL is the maximum when it is referred to one TCL period. It decreases according to the formula and to the Figure 12 given below. For N periods of TCL the minimum value is computed using the corresponding deviation D_N :

$$TCL_{MIN} = TCL_{NOM} \times \left(1 - \frac{[D_N]}{100} \right)$$

$$D_N = \pm(4 - N/15)[\%]$$

where N = number of consecutive TCL periods and $1 \leq N \leq 40$. So for a duration of 3 TCL periods ($N = 3$):

$$D_3 = 4 - 3/15 = 3.8\%$$

$$3TCL_{min} = 3TCL_{NOM} \times (1 - 3.8/100)$$

$$= 3TCL_{NOM} \times 0.962$$

$$3TCL_{min} = (57.72ns \text{ at } f_{CPU} = 25MHz)$$

This is especially important for bus cycles using wait states and for the operation of timers, serial interfaces, etc. For all slower operations and longer periods (e.g. pulse train generation or measurement, lower Baud rates, etc.) the deviation caused by the PLL jitter is negligible.

Figure 12 : Approximated maximum PLL jitter

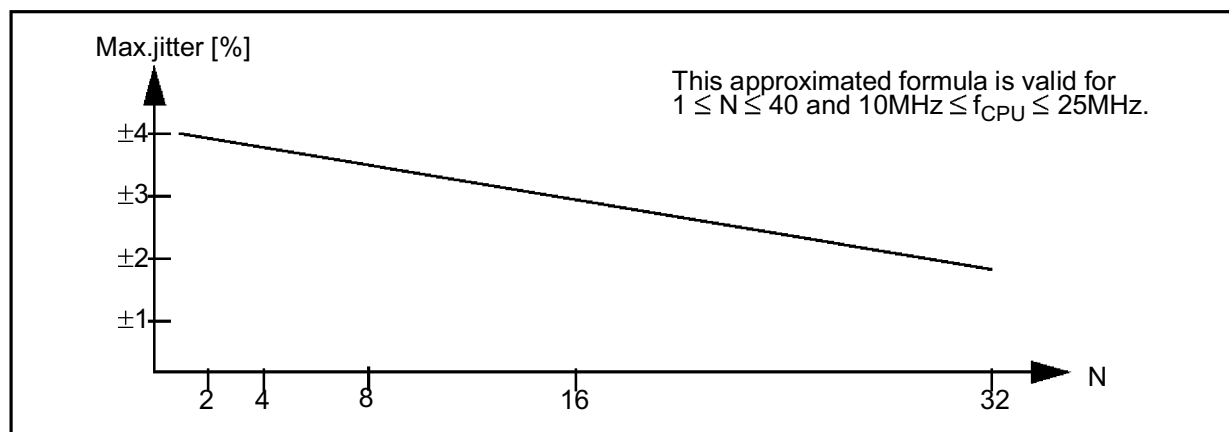

XX.4.7 - Memory cycle variables

The tables below use three variables which are derived from the BUSCONx registers and represent the special characteristics of the programmed memory cycle. The following table describes how these variables are to be computed.

Symbol	Description	Values
t_A	ALE Extension	$TCL * <ALECTL>$
t_C	Memory Cycle Time wait states	$2TCL * (15 - <MCTC>)$
t_F	Memory Tristate Time	$2TCL * (1 - <MTTC>)$

XX - ELECTRICAL CHARACTERISTICS (continued)**XX.4.8 - External clock drive XTAL1**

$V_{DD} = 5V \pm 10\%$, $V_{SS} = 0V$, $T_A = -40$ to $+125^\circ\text{C}$ unless otherwise specified.

Symbol	Parameter	$f_{\text{CPU}} = f_{\text{XTAL}}$		$f_{\text{CPU}} = f_{\text{XTAL}} / 2$		$f_{\text{CPU}} = f_{\text{XTAL}} * N$ $N = 1.5/2, 2.5/3/4/5$		Unit	
		Min.	Max.	Min.	Max.	Min.	Max.		
t_{osc}	SR	Oscillator period	40^1	1000	20^2	500	$40 * N$	$100 * N$	ns
t_1	SR	High time	18^3	–	6^3	–	10^3	–	ns
t_2	SR	Low time	18^3	–	6^3	–	10^3	–	ns
t_3	SR	Rise time	–	10^3	–	6^3	–	10^3	ns
t_4	SR	Fall time	–	10^3	–	6^3	–	10^3	ns

Notes 1. Theoretical minimum. The real minimum value depends on the duty cycle of the input clock signal.
2. 25MHz is the maximum input frequency when using an external crystal oscillator; however, 50MHz can be applied with an external clock source.
3. The input clock signal must reach the defined levels V_{IH2} and V_{IL2} .

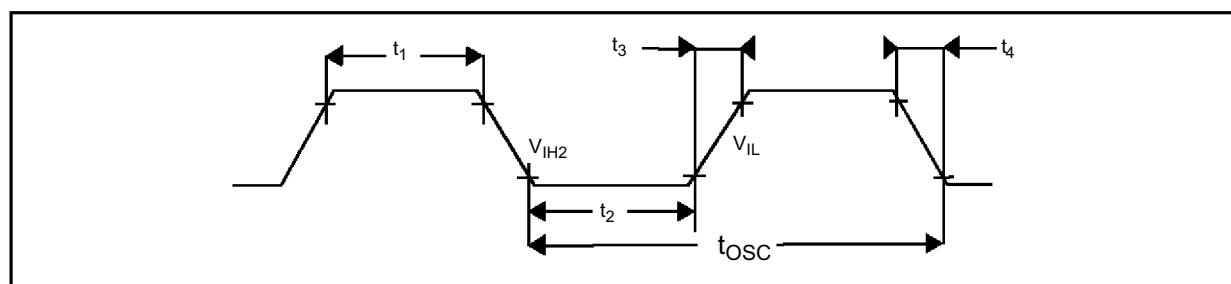
Figure 13 : External clock drive XTAL1**XX.4.9 - Multiplexed bus**

$V_{DD} = 5V \pm 10\%$, $V_{SS} = 0V$, $T_A = -40$ to $+125^\circ\text{C}$

C_L (for Port0, Port1, Port 4, ALE, $\overline{\text{RD}}$, $\overline{\text{WR}}$, $\overline{\text{BHE}}$, CLKOUT) = 100pF,

C_L (for Port 6, $\overline{\text{CS}}$) = 100pF

ALE cycle time = $6 \text{ TCL} + 2t_A + t_C + t_F$ (120ns at 25MHz CPU clock without wait states)

Table 18 : Multiplexed bus characteristics

Symbol	Parameter	Max. CPU Clock = 25MHz		Variable CPU Clock $1/2\text{TCL} = 1$ to 25MHz		Unit	
		Min.	Max.	Min.	Max.		
t_5	CC	ALE high time	$10 + t_A$	–	$\text{TCL} - 10 + t_A$	–	ns
t_6	CC	Address setup to ALE	$4 + t_A$	–	$\text{TCL} - 16 + t_A$	–	ns
t_7	CC	Address hold after ALE	$10 + t_A$	–	$\text{TCL} - 10 + t_A$	–	ns
t_8	CC	ALE falling edge to $\overline{\text{RD}}$, $\overline{\text{WR}}$ (with RW-delay)	$10 + t_A$	–	$\text{TCL} - 10 + t_A$	–	ns
t_9	CC	ALE falling edge to $\overline{\text{RD}}$, $\overline{\text{WR}}$ (no RW-delay)	$-10 + t_A$	–	$-10 + t_A$	–	ns

XX - ELECTRICAL CHARACTERISTICS (continued)

Table 18 : Multiplexed bus characteristics (continued)

Symbol	Parameter	Max. CPU Clock = 25MHz		Variable CPU Clock 1/2TCL = 1 to 25MHz		Unit		
		Min.	Max.	Min.	Max.			
t_{10}^1	CC	Address float after \overline{RD} , \overline{WR} (with RW-delay)		-	6	-	6	ns
t_{11}^1	CC	Address float after \overline{RD} , \overline{WR} (no RW-delay)		-	26	-	TCL + 6	ns
t_{12}	CC	\overline{RD} , \overline{WR} low time (with RW-delay)		$30 + t_C$	-	$2TCL - 10 + t_C$	-	ns
t_{13}	CC	\overline{RD} , \overline{WR} low time (no RW-delay)		$50 + t_C$	-	$3TCL - 10 + t_C$	-	ns
t_{14}	SR	\overline{RD} to valid data in (with RW-delay)		-	$20 + t_C$	-	$2TCL - 20 + t_C$	ns
t_{15}	SR	\overline{RD} to valid data in (no RW-delay)		-	$40 + t_C$	-	$3TCL - 20 + t_C$	ns
t_{16}	SR	ALE low to valid data in		-	$40 + t_A + t_C$	-	$3TCL - 20 + t_A + t_C$	ns
t_{17}	SR	Address/Unlatched \overline{CS} to valid data in		-	$50 + 2t_A + t_C$	-	$4TCL - 30 + 2t_A + t_C$	ns
t_{18}	SR	Data hold after \overline{RD} rising edge		0	-	0	-	ns
t_{19}^1	SR	Data float after \overline{RD}		-	$26 + t_F$	-	$2TCL - 14 + t_F$	ns
t_{22}	CC	Data valid to \overline{WR}		$20 + t_C$	-	$2TCL - 20 + t_C$	-	ns
t_{23}	CC	Data hold after \overline{WR}		$26 + t_F$	-	$2TCL - 14 + t_F$	-	ns
t_{25}	CC	ALE rising edge after \overline{RD} , \overline{WR}		$26 + t_F$	-	$2TCL - 14 + t_F$	-	ns
t_{27}	CC	Address/Unlatched \overline{CS} hold after \overline{RD} , \overline{WR}		$26 + t_F$	-	$2TCL - 14 + t_F$	-	ns
t_{38}	CC	ALE falling edge to Latched \overline{CS}		$-4 - t_A$	$10 - t_A$	$-4 - t_A$	$10 - t_A$	ns
t_{39}	SR	Latched \overline{CS} low to valid data in		-	$40 + t_C + 2t_A$	-	$3TCL - 20 + t_C + 2t_A$	ns
t_{40}	CC	Latched \overline{CS} hold after \overline{RD} , \overline{WR}		$46 + t_F$	-	$3TCL - 14 + t_F$	-	ns
t_{42}	CC	ALE fall. edge to \overline{RdCS} , \overline{WrCS} (with RW delay)		$16 + t_A$	-	$TCL - 4 + t_A$	-	ns
t_{43}	CC	ALE fall. edge to \overline{RdCS} , \overline{WrCS} (no RW delay)		$-4 + t_A$	-	$-4 + t_A$	-	ns
t_{44}^1	CC	Address float after \overline{RdCS} , \overline{WrCS} (with RW delay)		-	0	-	0	ns
t_{45}^1	CC	Address float after \overline{RdCS} , \overline{WrCS} (no RW delay)		-	20	-	TCL	ns
t_{46}	SR	\overline{RdCS} to Valid Data In (with RW delay)		-	$16 + t_C$	-	$2TCL - 24 + t_C$	ns
t_{47}	SR	\overline{RdCS} to Valid Data In (no RW delay)		-	$36 + t_C$	-	$3TCL - 24 + t_C$	ns

XX - ELECTRICAL CHARACTERISTICS (continued)

Table 18 : Multiplexed bus characteristics (continued)

Symbol	Parameter	Max. CPU Clock = 25MHz		Variable CPU Clock 1/2TCL = 1 to 25MHz		Unit	
		Min.	Max.	Min.	Max.		
t ₄₈	CC	$\overline{\text{RdCS}}$, $\overline{\text{WrCS}}$ Low Time (with RW delay)	$30 + t_C$	–	$2\text{TCL} - 10 + t_C$	–	ns
t ₄₉	CC	$\overline{\text{RdCS}}$, $\overline{\text{WrCS}}$ Low Time (no RW delay)	$50 + t_C$	–	$3\text{TCL} - 10 + t_C$	–	ns
t ₅₀	CC	Data valid to $\overline{\text{WrCS}}$	$26 + t_C$	–	$2\text{TCL} - 14 + t_C$	–	ns
t ₅₁	SR	Data hold after $\overline{\text{RdCS}}$	0	–	0	–	ns
t ₅₂ ¹	SR	Data float after $\overline{\text{RdCS}}$	–	$20 + t_F$	–	$2\text{TCL} - 20 + t_F$	ns
t ₅₄	CC	Address hold after $\overline{\text{RdCS}}$, $\overline{\text{WrCS}}$	$20 + t_F$	–	$2\text{TCL} - 20 + t_F$	–	ns
t ₅₆	CC	Data hold after $\overline{\text{WrCS}}$	$20 + t_F$	–	$2\text{TCL} - 20 + t_F$	–	ns

Note 1. Guaranteed by design characterization.

XX - ELECTRICAL CHARACTERISTICS (continued)

Figure 14 : External Memory Cycle : multiplexed bus, with/without read/write delay, normal ALE

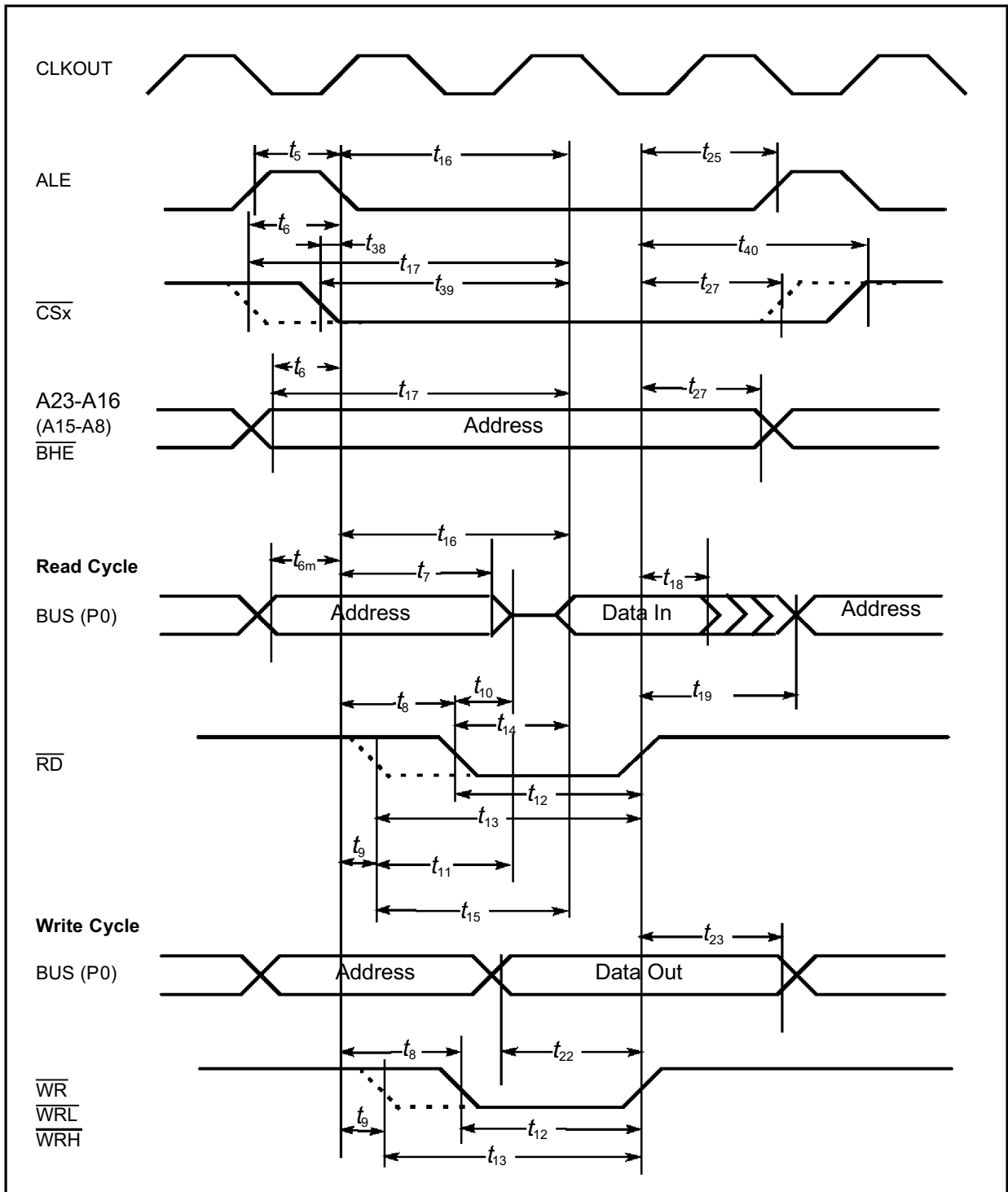

XX - ELECTRICAL CHARACTERISTICS (continued)

Figure 15 : External Memory Cycle: multiplexed bus, with/without read/write delay, extended ALE

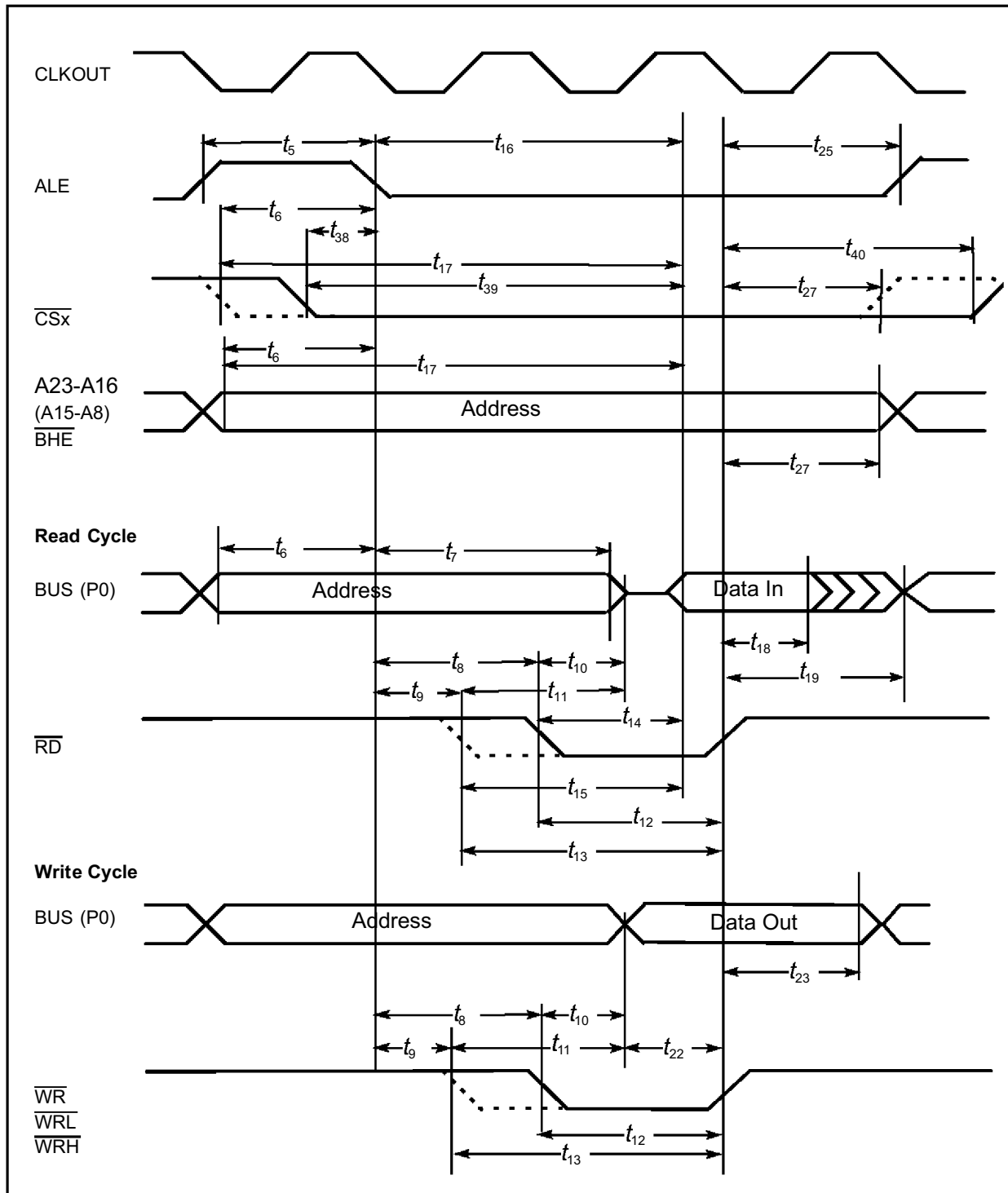

XX - ELECTRICAL CHARACTERISTICS (continued)

Figure 16 : External Memory Cycle: multiplexed bus, with/without read/write delay, normal ALE, read/write chip select

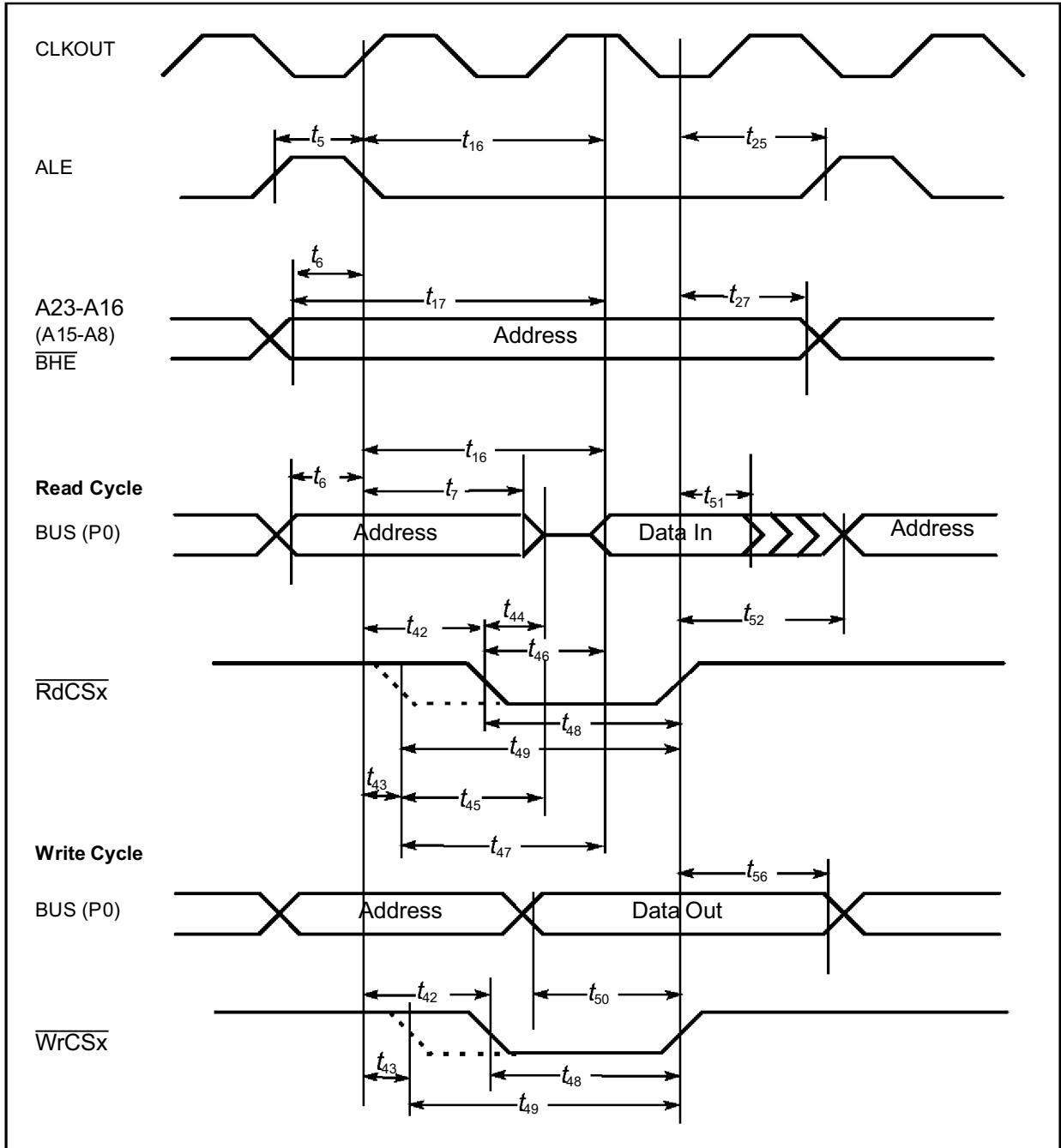

XX - ELECTRICAL CHARACTERISTICS (continued)

Figure 17 : External Memory Cycle: multiplexed bus, with/without read/write delay, extended ALE, read/write chip select

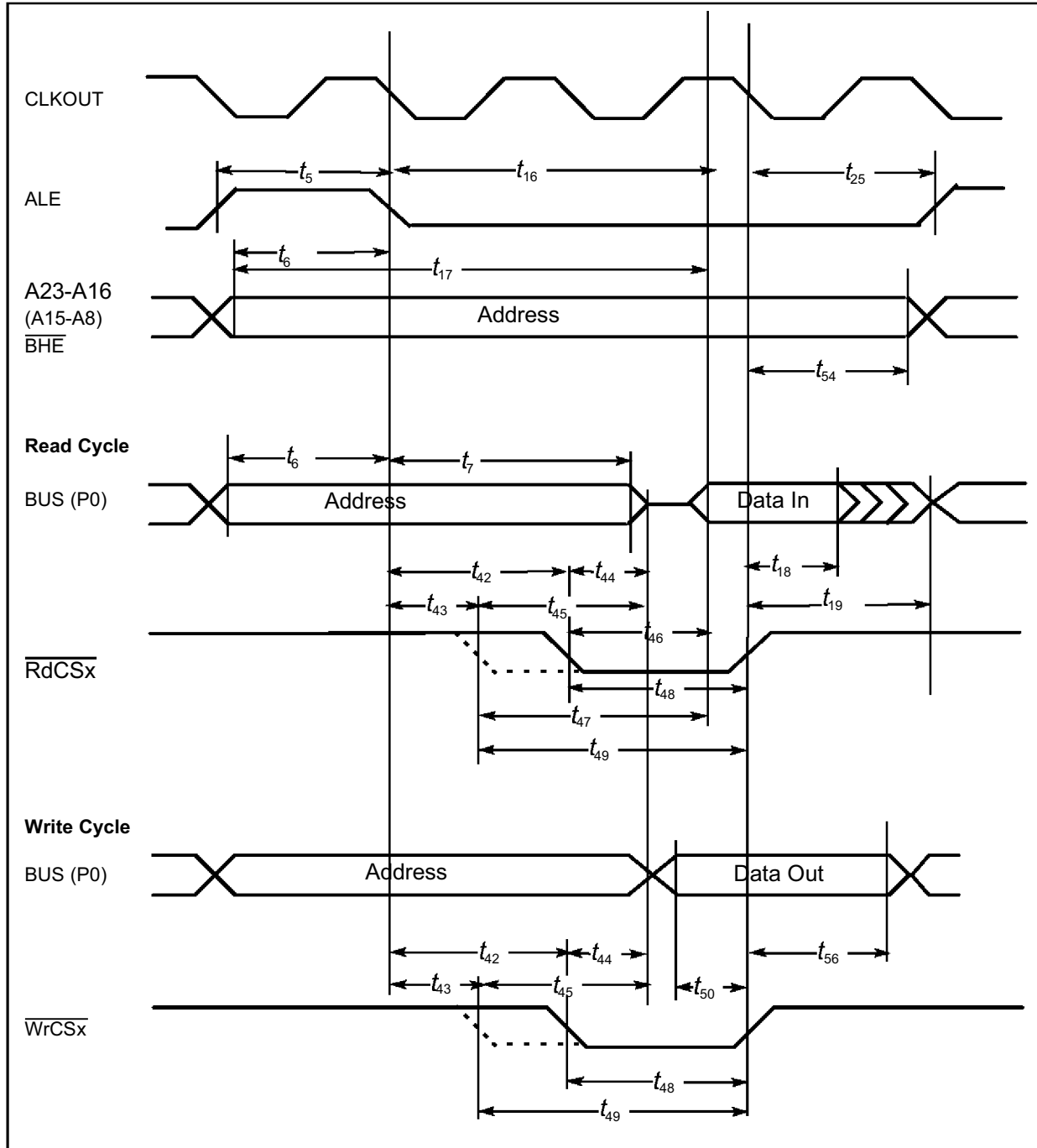

XX - ELECTRICAL CHARACTERISTICS (continued)**XX.4.10 - Demultiplexed bus**

$V_{DD} = 5V \pm 10\%$, $V_{SS} = 0V$, $T_A = -40$ to $+125^\circ\text{C}$

C_L (for Port0, Port1, Port 4, ALE, \overline{RD} , \overline{WR} , \overline{BHE} , CLKOUT) = 100pF,

C_L (for Port 6, \overline{CS}) = 100pF

ALE cycle time = $4 \text{ TCL} + 2t_A + t_C + t_F$ (80ns at 25MHz CPU clock without wait states)

Table 19 : Demultiplexed bus characteristics

Symbol	Parameter	Max. CPU Clock = 25MHz		Variable CPU Clock 1/2TCL = 1 to 25MHz		Unit
		Min.	Max.	Min.	Max.	
t_5 CC	ALE high time	$10 + t_A$	–	$\text{TCL} - 10 + t_A$	–	ns
t_6 CC	Address setup to ALE	$4 + t_A$	–	$\text{TCL} - 16 + t_A$	–	ns
t_8 CC	ALE falling edge to \overline{RD} , \overline{WR} (with RW-delay)	$10 + t_A$	–	$\text{TCL} - 10 + t_A$	–	ns
t_9 CC	ALE falling edge to \overline{RD} , \overline{WR} (no RW-delay)	$-10 + t_A$	–	$-10 + t_A$	–	ns
t_{12} CC	\overline{RD} , \overline{WR} low time (with RW-delay)	$30 + t_C$	–	$2\text{TCL} - 10 + t_C$	–	ns
t_{13} CC	\overline{RD} , \overline{WR} low time (no RW-delay)	$50 + t_C$	–	$3\text{TCL} - 10 + t_C$	–	ns
t_{14} SR	\overline{RD} to valid data in (with RW-delay)	–	$20 + t_C$	–	$2\text{TCL} - 20 + t_C$	ns
t_{15} SR	\overline{RD} to valid data in (no RW-delay)	–	$40 + t_C$	–	$3\text{TCL} - 20 + t_C$	ns
t_{16} SR	ALE low to valid data in	–	$40 + t_A + t_C$	–	$3\text{TCL} - 20 + t_A + t_C$	ns
t_{17} SR	Address/Unlatched \overline{CS} to valid data in	–	$50 + 2t_A + t_C$	–	$4\text{TCL} - 30 + 2t_A + t_C$	ns
t_{18} SR	Data hold after \overline{RD} rising edge	0	–	0	–	ns
t_{20}^1 SR	Data float after \overline{RD} rising edge (with RW-delay ¹)	–	$26 + t_F$	–	$2\text{TCL} - 14 + t_F + 2t_A^2$	ns
t_{21}^1 SR	Data float after \overline{RD} rising edge (no RW-delay ¹)	–	$10 + t_F$	–	$\text{TCL} - 10 + t_F + 2t_A^2$	ns
t_{22} CC	Data valid to \overline{WR}	$20 + t_C$	–	$2\text{TCL} - 20 + t_C$	–	ns
t_{24} CC	Data hold after \overline{WR}	$10 + t_F$	–	$\text{TCL} - 10 + t_F$	–	ns
t_{26} CC	ALE rising edge after \overline{RD} , \overline{WR}	$-10 + t_F$	–	$-10 + t_F$	–	ns
t_{28} CC	Address/Unlatched \overline{CS} hold after \overline{RD} , \overline{WR} ²	$0 + t_F$	–	$0 + t_F$	–	ns
t_{38} CC	ALE falling edge to Latched \overline{CS}	$-4 - t_A$	$10 - t_A$	$-4 - t_A$	$10 - t_A$	ns
t_{39} SR	Latched \overline{CS} low to Valid Data In	–	$40 + t_C + 2t_A$	–	$3\text{TCL} - 20 + t_C + 2t_A$	ns
t_{41} CC	Latched \overline{CS} hold after \overline{RD} , \overline{WR}	$6 + t_F$	–	$\text{TCL} - 14 + t_F$	–	ns
t_{42} CC	ALE falling edge to \overline{RdCS} , \overline{WrCS} (with RW-delay)	$16 + t_A$	–	$\text{TCL} - 4 + t_A$	–	ns

Table 19 : Demultiplexed bus characteristics (continued)

Symbol	Parameter	Max. CPU Clock = 25MHz		Variable CPU Clock 1/2TCL = 1 to 25MHz		Unit
		Min.	Max.	Min.	Max.	
t ₄₃ CC	ALE falling edge to $\overline{\text{RdCS}}$, $\overline{\text{WrCS}}$ (no RW-delay)	-4 + t _A	-	-4 + t _A	-	ns
t ₄₆ SR	$\overline{\text{RdCS}}$ to Valid Data In (with RW-delay)	-	16 + t _C	-	2TCL - 24 + t _C	ns
t ₄₇ SR	$\overline{\text{RdCS}}$ to Valid Data In (no RW-delay)	-	36 + t _C	-	3TCL - 24 + t _C	ns
t ₄₈ CC	$\overline{\text{RdCS}}$, $\overline{\text{WrCS}}$ Low Time (with RW-delay)	30 + t _C	-	2TCL - 10 + t _C	-	ns
t ₄₉ CC	$\overline{\text{RdCS}}$, $\overline{\text{WrCS}}$ Low Time (no RW-delay)	50 + t _C	-	3TCL - 10 + t _C	-	ns
t ₅₀ CC	Data valid to $\overline{\text{WrCS}}$	26 + t _C	-	2TCL - 14 + t _C	-	ns
t ₅₁ SR	Data hold after $\overline{\text{RdCS}}$	0	-	0	-	ns
t ₅₃ ¹ SR	Data float after $\overline{\text{RdCS}}$ (with RW-delay)	-	20 + t _F	-	2TCL - 20 + t _F	ns
t ₆₈ ¹ SR	Data float after $\overline{\text{RdCS}}$ (no RW-delay)	-	0 + t _F	-	TCL - 20 + t _F	ns
t ₅₅ CC	Address hold after $\overline{\text{RdCS}}$, $\overline{\text{WrCS}}$	-10 + t _F	-	-10 + t _F	-	ns
t ₅₇ CC	Data hold after $\overline{\text{WrCS}}$	6 + t _F	-	TCL - 14 + t _F	-	ns

Notes 1. Guaranteed by design characterization.

2. RW-delay and t_A refer to the next following bus cycle.

3. Read data is latched with the same clock edge that triggers the address change and the rising $\overline{\text{RD}}$ edge. Therefore address changes before the end of $\overline{\text{RD}}$ have no impact on read cycles.

XX - ELECTRICAL CHARACTERISTICS (continued)

Figure 18 : External Memory Cycle: demultiplexed bus, with/without read/write delay, normal ALE

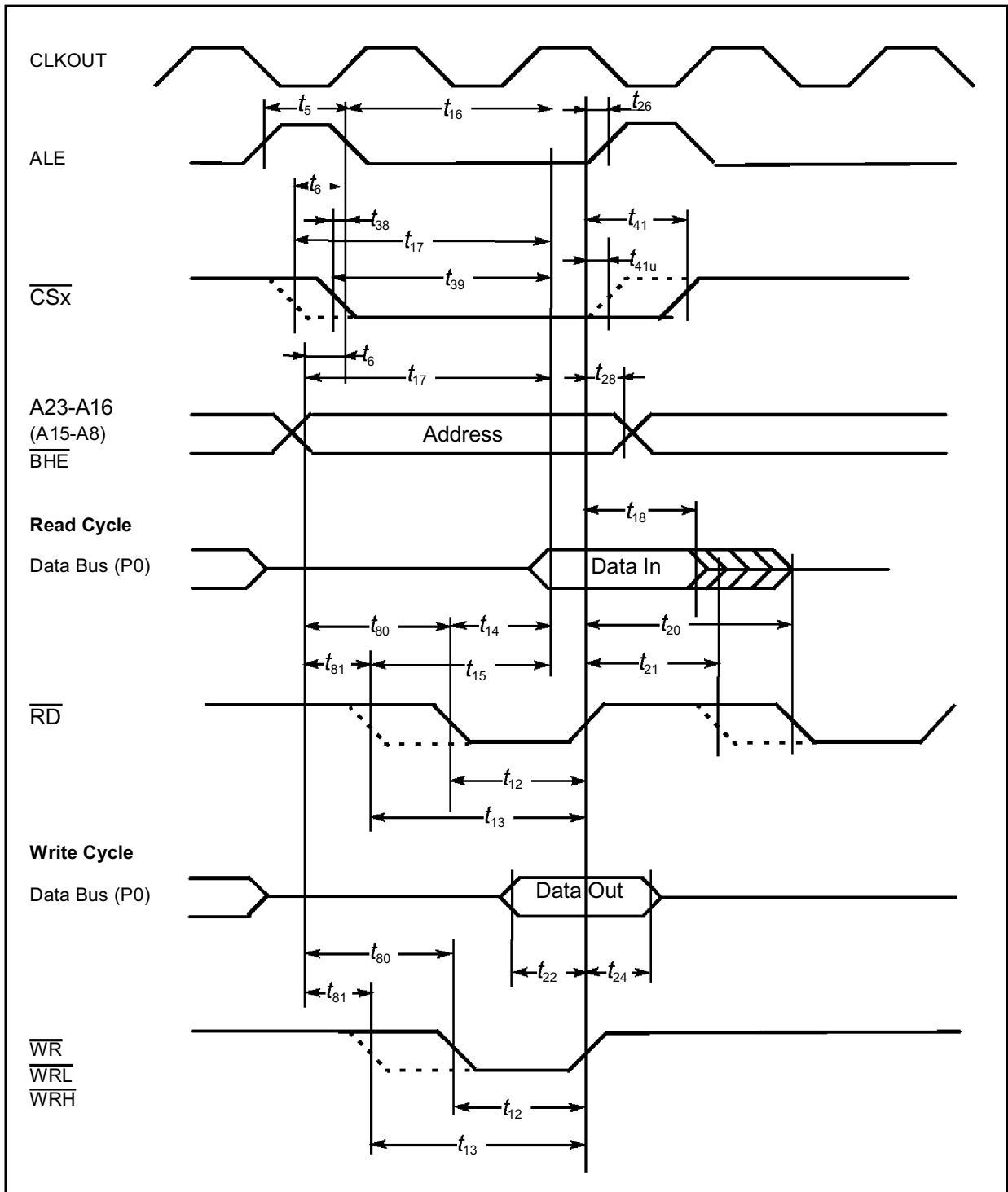

XX - ELECTRICAL CHARACTERISTICS (continued)

Figure 19 : External Memory Cycle: demultiplexed bus, with/without read/write delay, extended ALE

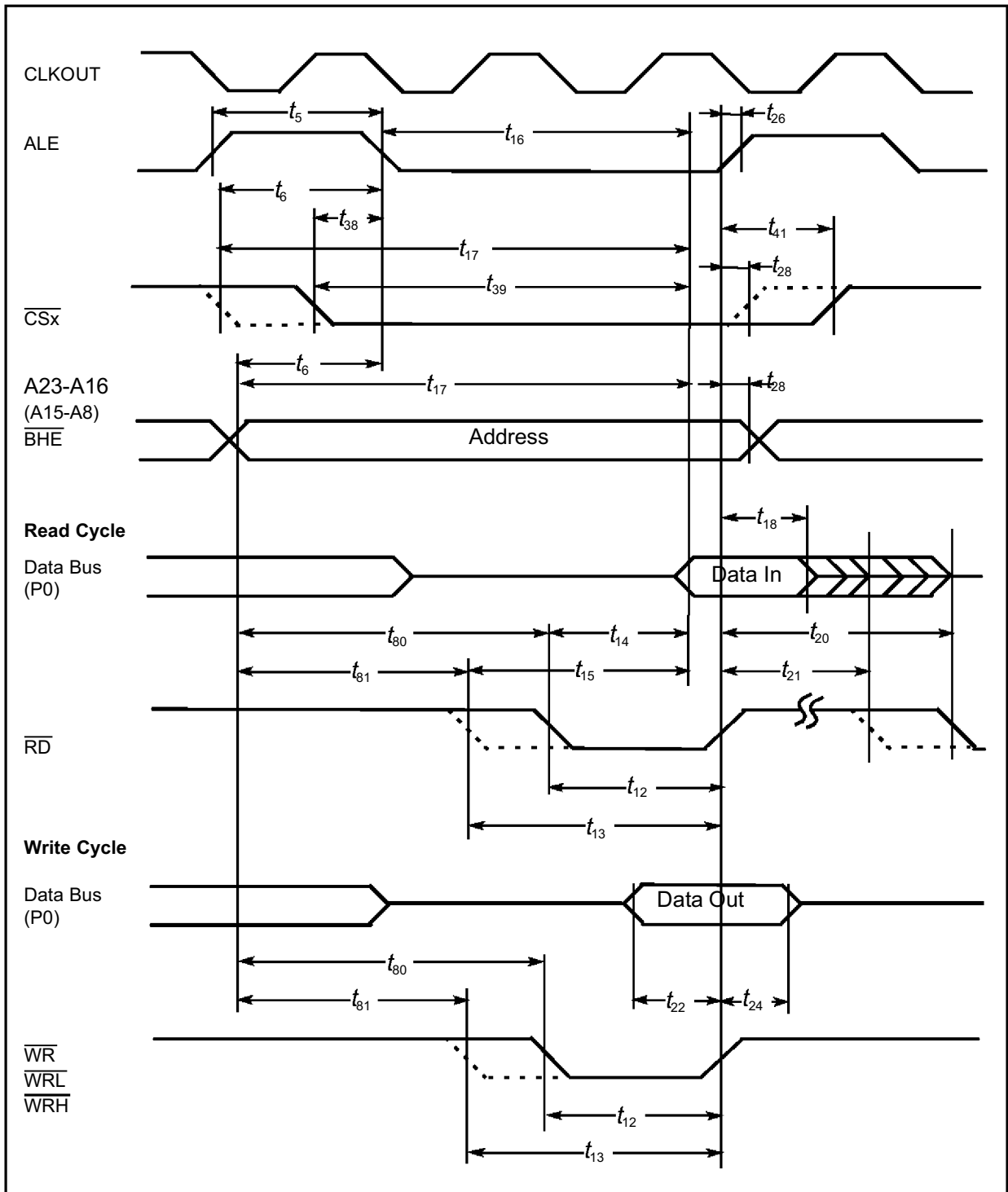

XX - ELECTRICAL CHARACTERISTICS (continued)

Figure 20 : External Memory Cycle: demultiplexed bus, with/without read/write delay, normal ALE, read/write chip select

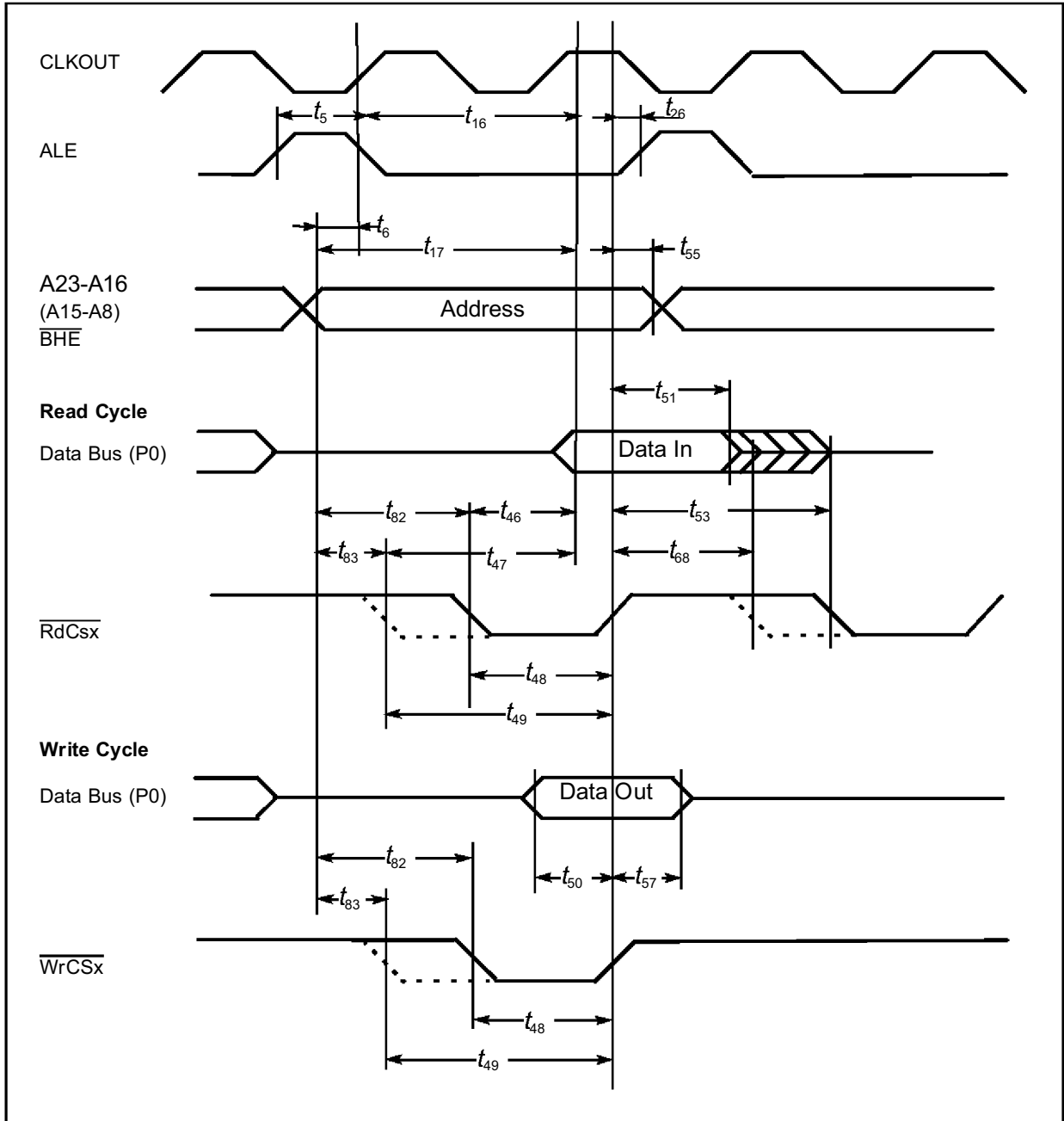

XX - ELECTRICAL CHARACTERISTICS (continued)

Figure 21 : External Memory Cycle: demultiplexed bus, with/without read/write delay, extended ALE, read/write chip select

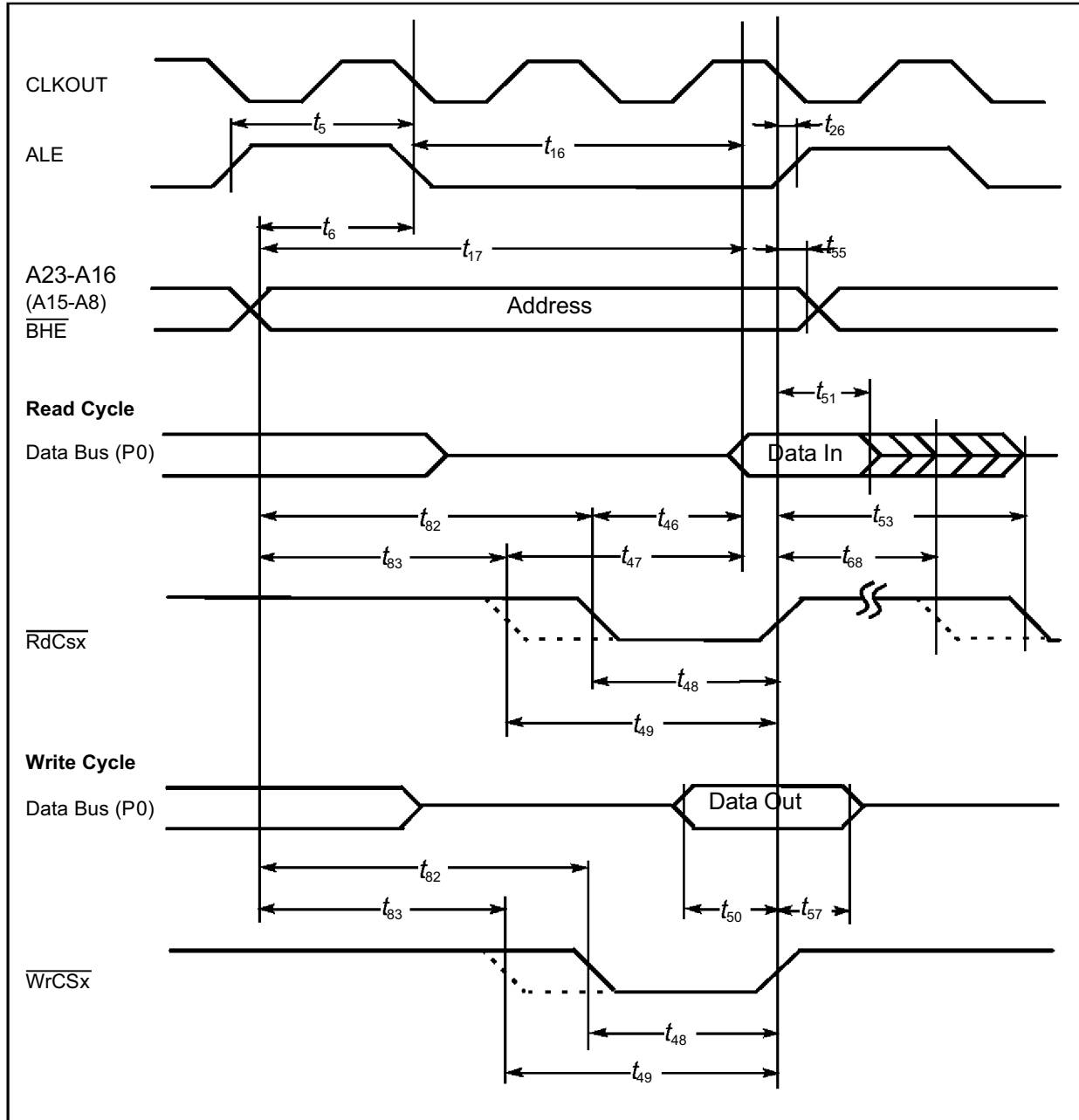

XX - ELECTRICAL CHARACTERISTICS (continued)

XX.4.11 - CLKOUT and $\overline{\text{READY}}$

$V_{DD} = 5V \pm 10\%$, $V_{SS} = 0V$, $T_A = -40$ to $+125^\circ\text{C}$

C_L (for Port0, Port1, Port 4, ALE, $\overline{\text{RD}}$, $\overline{\text{WR}}$, BHE, CLKOUT) = 100pF

C_L (for Port 6, $\overline{\text{CS}}$) = 100pF

Table 20 : CLKOUT and $\overline{\text{READY}}$ characteristics

Symbol	Parameter	Max. CPU Clock = 25MHz		Variable CPU Clock 1/2TCL = 1 to 25MHz		Unit
		Min.	Max.	Min.	Max.	
t ₂₉ CC	CLKOUT cycle time	40	40	2TCL	2TCL	ns
t ₃₀ CC	CLKOUT high time	14	–	TCL – 6	–	ns
t ₃₁ CC	CLKOUT low time	10	–	TCL – 10	–	ns
t ₃₂ CC	CLKOUT rise time	–	4	–	4	ns
t ₃₃ CC	CLKOUT fall time	–	4	–	4	ns
t ₃₄ CC	CLKOUT rising edge to ALE falling edge	0 + t _A	10 + t _A	0 + t _A	10 + t _A	ns
t ₃₅ SR	Synchronous $\overline{\text{READY}}$ setup time to CLKOUT	14	–	14	–	ns
t ₃₆ SR	Synchronous $\overline{\text{READY}}$ hold time after CLKOUT	4	–	4	–	ns
t ₃₇ SR	Asynchronous $\overline{\text{READY}}$ low time	54	–	2TCL + 14	–	ns
t ₅₈ SR	Asynchronous $\overline{\text{READY}}$ setup time ¹	14	–	14	–	ns
t ₅₉ SR	Asynchronous $\overline{\text{READY}}$ hold time ¹	4	–	4	–	ns
t ₆₀ SR	Async. $\overline{\text{READY}}$ hold time after $\overline{\text{RD}}$, $\overline{\text{WR}}$ high (Demultiplexed Bus) ²	0	0 + 2t _A + t _C + t _F ²	0	TCL - 20 + 2t _A + t _C + t _F ²	ns

Notes 1. These timings are given for test purposes only, in order to assure recognition at a specific clock edge.

2. Demultiplexed bus is the worst case. For multiplexed bus 2TCL are to be added to the maximum values. This adds even more time for deactivating $\overline{\text{READY}}$.

The 2t_A and t_C refer to the next following bus cycle, t_F refers to the current bus cycle.

XX - ELECTRICAL CHARACTERISTICS (continued)

Figure 22 : CLKOUT and $\overline{\text{READY}}$

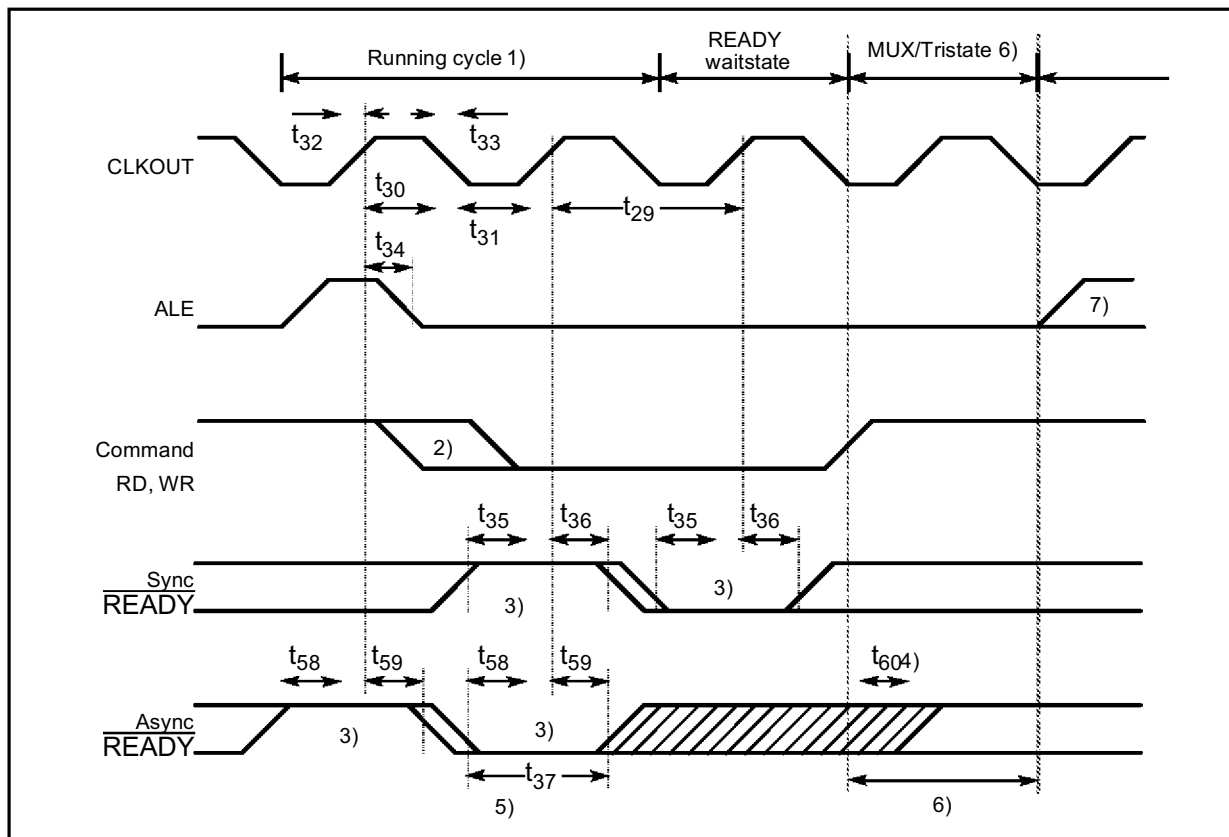

Notes 1. Cycle as programmed, including MCTC waitstates (Example shows 0 MCTC WS).

2. The leading edge of the respective command depends on RW-delay.

3. $\overline{\text{READY}}$ sampled HIGH at this sampling point generates a READY controlled wait state, $\overline{\text{READY}}$ sampled LOW at this sampling point terminates the currently running bus cycle.

4. $\overline{\text{READY}}$ may be deactivated in response to the trailing (rising) edge of the corresponding command ($\overline{\text{RD}}$ or $\overline{\text{WR}}$).

5. If the Asynchronous $\overline{\text{READY}}$ signal does not fulfill the indicated setup and hold times with respect to CLKOUT (e.g. because CLKOUT is not enabled), it must fulfill t_{37} in order to be safely synchronized. This is guaranteed, if $\overline{\text{READY}}$ is removed in response to the command (see Note 4)).

6. Multiplexed bus modes have a MUX waitstate added after a bus cycle, and an additional MTTC waitstate may be inserted here. For a multiplexed bus with MTTC waitstate this delay is 2 CLKOUT cycles, for a demultiplexed bus without MTTC waitstate this delay is zero.

7. The next external bus cycle may start here.

XX - ELECTRICAL CHARACTERISTICS (continued)

XX.4.12 - External bus arbitration

$V_{DD} = 5V \pm 10\%$, $V_{SS} = 0V$, $T_A = -40$ to $+125^\circ C$

C_L (for Port0, Port1, Port 4, ALE, \overline{RD} , \overline{WR} , \overline{BHE} , CLKOUT) = 100pF

C_L (for Port 6, \overline{CS}) = 100pF

Table 21 : External bus arbitration

Symbol	Parameter	Max. CPU Clock = 25MHz		Variable CPU Clock 1/2TCL = 1 to 25MHz		Unit
		Min.	Max.	Min.	Max.	
t ₆₁	SR \overline{HOLD} input setup time to CLKOUT	20	–	20	–	ns
t ₆₂	CC CLKOUT to \overline{HLDA} hig or \overline{BREQ} low delay	–	20	–	20	ns
t ₆₃	CC CLKOUT to \overline{HLDA} low or \overline{BREQ} high delay	–	20	–	20	ns
t ₆₄	CC \overline{CSx} release	– ₁	20	–	20	ns
t ₆₅	CC \overline{CSx} drive	–4	24	–4	24	ns
t ₆₆	CC Other signals release	– ₁	20	–	20	ns
t ₆₇	CC Other signals drive	–4	24	–4	24	ns

Note 1. Guaranteed by design characterization.

Figure 23 : External bus arbitration, releasing the bus

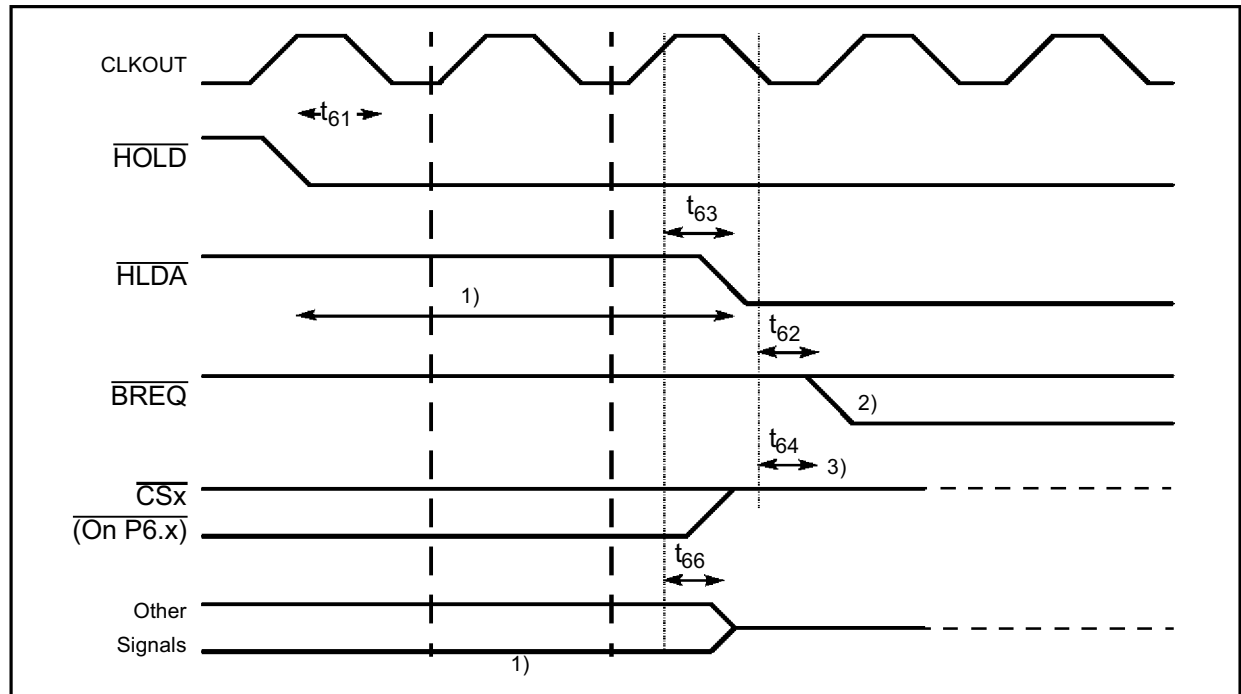

- Notes 1. The ST10C167 will complete the currently running bus cycle before granting bus access.
- 2. This is the first possibility for BREQ to become active.
- 3. The \overline{CS} outputs will be resistive high (pullup) after t₆₄.

XX - ELECTRICAL CHARACTERISTICS (continued)

Figure 24 : External bus arbitration, (regaining the bus)

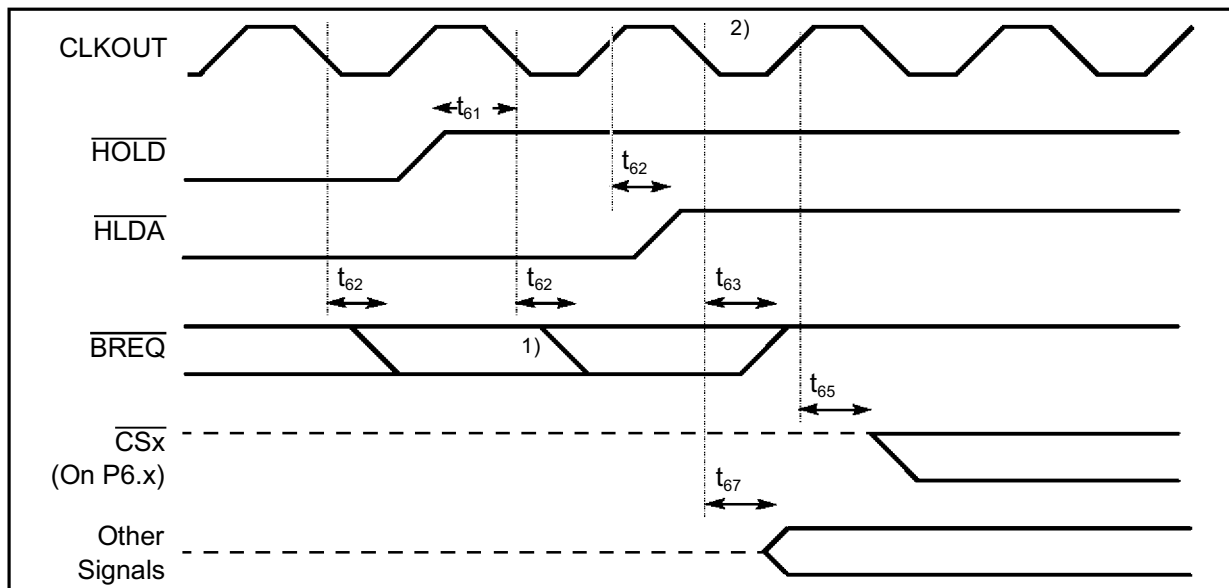

Notes 1. This is the last opportunity for BREQ to trigger the indicated regain-sequence. Even if BREQ is activated earlier, the regain-sequence is initiated by HOLD going high. Please note that HOLD may also be deactivated without the ST10C167 requesting the bus.
 2. The next ST10C167 driven bus cycle may start here.

XX.4.13 - High-speed synchronous serial interface (SSC) timing

Master mode

V_{CC} = 5V ±10%, V_{SS} = 0V, CPU clock = 25MHz, T_A = -40 to +125°C, C_L = 100pF

Symbol	Parameter	Max. Baud rate = 6.25M Baud (<SSCBR> = 0001h)		Variable Baud rate (<SSCBR>=0001h-FFFFh)		Unit
		Min.	Max.	Min.	Max.	
t ₃₀₀	CC SSC clock cycle time	160	160	8 TCL	262144 TCL	ns
t ₃₀₁	CC SSC clock high time	70	-	t ₃₀₀ /2 - 10	-	ns
t ₃₀₂	CC SSC clock low time	70	-	t ₃₀₀ /2 - 10	-	ns
t ₃₀₃	CC SSC clock rise time	-	10	-	10	ns
t ₃₀₄	CC SSC clock fall time	-	10	-	10	ns
t ₃₀₅	CC Write data valid after shift edge	-	15	-	15	ns
t ₃₀₆ ¹	CC Write data hold after shift edge	-2	-	-2	-	ns
t _{307p}	SR Read data setup time before latch edge, phase error detection on (SSCPEN = 1)	60	-	2TCL+20	-	ns
t _{308p}	SR Read data hold time after latch edge, phase error detection on (SSCPEN = 1)	4TCL	-	4TCL	-	ns
t ₃₀₇	SR Read data setup time before latch edge, phase error detection off (SSCPEN = 0)	40	-	40	-	ns
t ₃₀₈	SR Read data hold time after latch edge, phase error detection off (SSCPEN = 0)	0	-	0	-	ns

Note 1. timing guaranteed by design.

XX - ELECTRICAL CHARACTERISTICS (continued)

The formula for SSC Clock Cycle time is : $t_{300} = 4 \text{ TCL} * (<\text{SSCBR}> + 1)$

Where <SSCBR> represents the content of the SSC Baud rate register, taken as unsigned 16-bit integer.

Figure 25 : SSC master timing

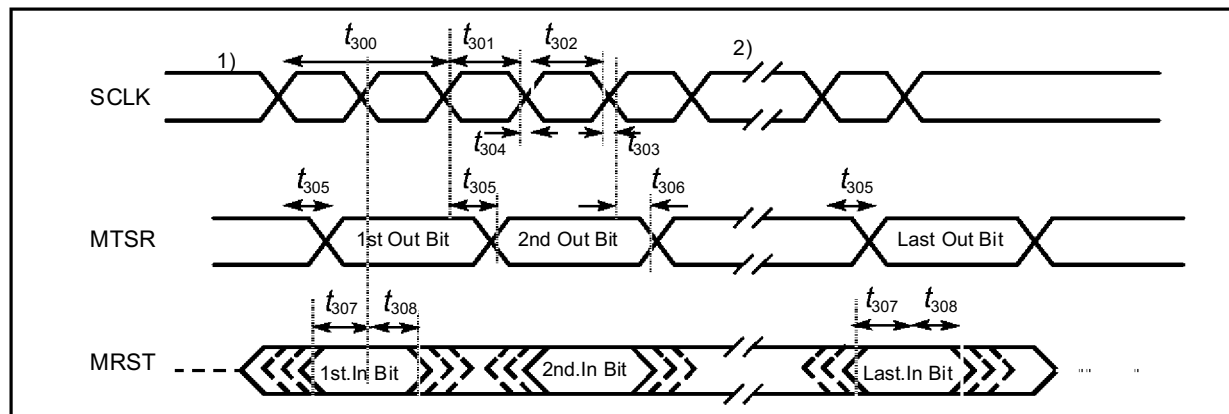

Notes 1. The phase and polarity of shift and latch edge of SCLK is programmable. This figure uses the leading clock edge as shift edge (drawn in bold), with latch on trailing edge (SSCPH = 0b), Idle clock line is low, leading clock edge is low-to-high transition (SSCPO = 0b).
 2. The bit timing is repeated for all bits to be transmitted or received.

Slave mode

V_{CC} = 5V ±10%, V_{SS} = 0V, CPU clock = 25MHz, T_A = -40 to +125°C, C_L = 100pF

Symbol	Parameter	Max Baud rate=6.25MBd (<SSCBR> = 0001h)		Variable Baud rate (<SSCBR>=0001h-FFFFh)		Unit	
		Min.	Max.	Min.	Max.		
t ₃₁₀	SR	SSC clock cycle time	160	160	8 TCL	262144 TCL	ns
t ₃₁₁	SR	SSC clock high time	70	–	t ₃₁₀ /2 - 10	–	ns
t ₃₁₂	SR	SSC clock low time	70	–	t ₃₁₀ /2 - 10	–	ns
t ₃₁₃	SR	SSC clock rise time	–	10	–	10	ns
t ₃₁₄	SR	SSC clock fall time	–	10	–	10	ns
t ₃₁₅	CC	Write data valid after shift edge	–	54	–	2 TCL + 14	ns
t ₃₁₆	CC	Write data hold after shift edge	0	–	0	–	ns
t _{317p}	SR	Read data setup time before latch edge, phase error detection on (SSCPEN = 1)	100	–	4TCL + 20	–	ns
t _{318p}	SR	Read data hold time after latch edge, phase error detection on (SSCPEN = 1)	140	–	6TCL + 20	–	ns
t ₃₁₇	SR	Read data setup time before latch edge, phase error detection off (SSCPEN = 0)	10	–	10	–	ns
t ₃₁₈	SR	Read data hold time after latch edge, phase error detection off (SSCPEN = 0)	0	–	0	–	ns

Note 1. Timing guaranteed by design.

XX - ELECTRICAL CHARACTERISTICS (continued)

The formula for SSC Clock Cycle time is: $t_{310} = 4 \text{ TCL} * (<\text{SSCBR}> + 1)$

Where $<\text{SSCBR}>$ represents the content of the SSC Baud rate register, taken as unsigned 16-bit integer.

Figure 26 : SSC slave timing

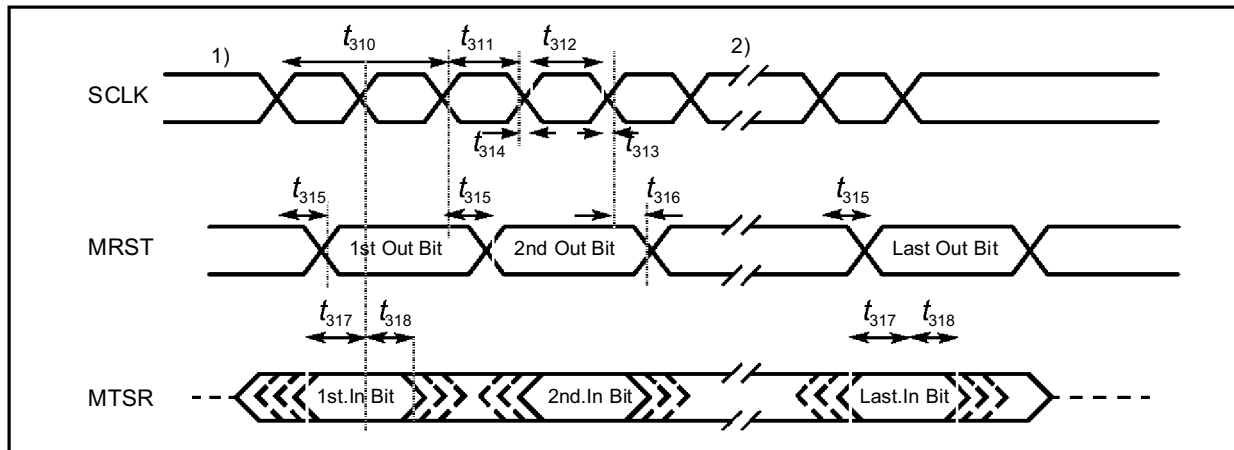

Notes 1. The phase and polarity of shift and latch edge of SCLK is programmable. This figure uses the leading clock edge as shift edge (drawn in bold), with latch on trailing edge ($\text{SSCPH} = 0b$), Idle clock line is low, leading clock edge is low-to-high transition ($\text{SSCPO} = 0b$).
2. The bit timing is repeated for all bits to be transmitted or received.

XXI - PACKAGE MECHANICAL DATA

Figure 27 : Package Outline PQFP144 (28 x 28mm)

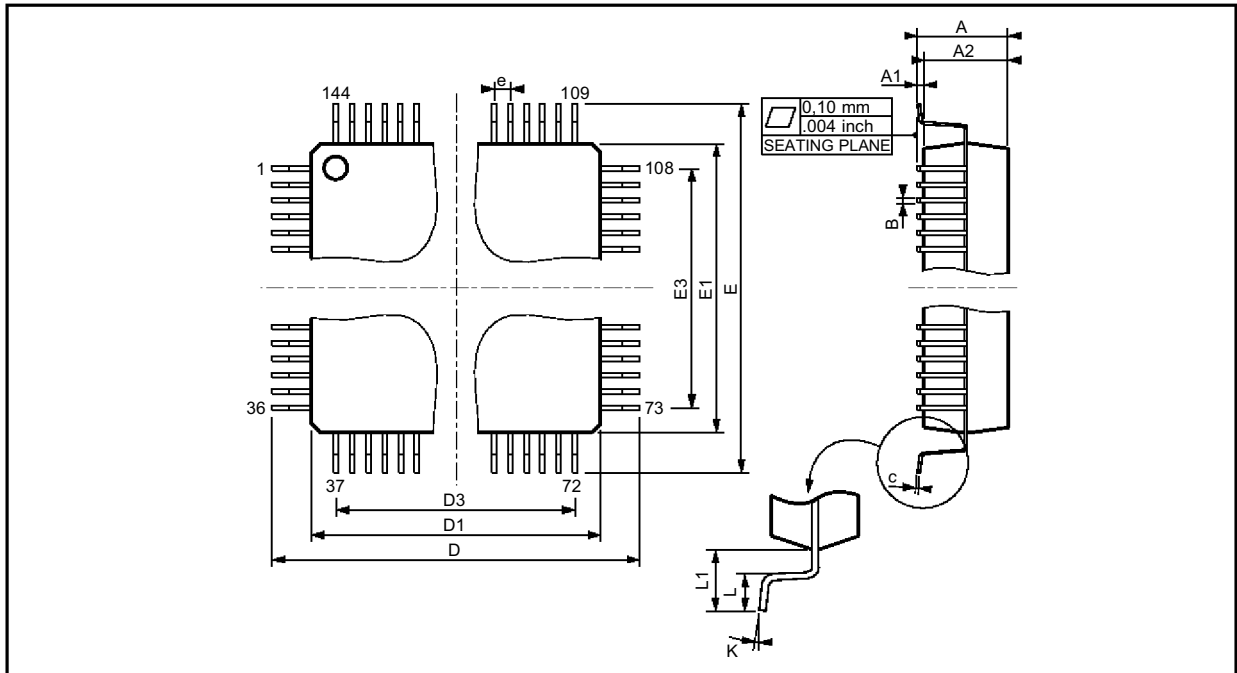

Dimensions	Millimeters ¹			Inches (approx)		
	Minimum	Typical	Maximum	Minimum	Typical	Maximum
A			4.07			0.160
A1	0.25			0.010		
A2	3.17	3.42	3.67	0.125	0.133	0.144
B	0.22		0.38	0.009		0.015
c	0.13		0.23	0.005		0.009
D	30.95	31.20	31.45	1.219	1.228	1.238
D1	27.90	28.00	28.10	1.098	1.102	1.106
D3		22.75			0.896	
e		0.65			0.026	
E	30.95	31.20	31.45	1.219	1.228	1.238
E1	27.90	28.00	28.10	1.098	1.102	1.106
L	0.65	0.80	0.95	0.026	0.031	0.037
L1		1.60			0.063	
K	0° (Min.), 7° (Max.)					

Note 1. Package dimensions are in mm. The dimensions quoted in inches are rounded.

XXII - ORDERING INFORMATION

Salestype	Temperature Range	Package
ST10C167-Q3/XX ¹	-40°C to 125°C	PQFP144 (28 x 28mm)
ST10C167-Q6/XX ¹	-40°C to 85°C	PQFP144 (28 x 28mm)

Note XX : ROM code identification characters

Information furnished is believed to be accurate and reliable. However, STMicroelectronics assumes no responsibility for the consequences of use of such information nor for any infringement of patents or other rights of third parties which may result from its use. No license is granted by implication or otherwise under any patent or patent rights of STMicroelectronics. Specifications mentioned in this publication are subject to change without notice. This publication supersedes and replaces all information previously supplied. STMicroelectronics products are not authorized for use as critical components in life support devices or systems without express written approval of STMicroelectronics.

The ST logo is a registered trademark of STMicroelectronics

© 1999 STMicroelectronics - All Rights Reserved
STMicroelectronics GROUP OF COMPANIES

Australia - Brazil - Canada - China - France - Germany - Italy - Japan - Korea - Malaysia - Malta - Mexico - Morocco
The Netherlands - Singapore - Spain - Sweden - Switzerland - Taiwan - Thailand - United Kingdom - U.S.A.
<http://www.st.com>

