

# SN75185 MULTIPLE RS-232 DRIVERS AND RECEIVERS

SLLS181C – DECEMBER 1994 – REVISED OCTOBER 2003

- **Single Chip With Easy Interface Between UART and Serial-Port Connector of IBM™ PC/AT™ and Compatibles**
- **Meets or Exceeds the Requirements of TIA/EIA-232-F and ITU v.28 Standards**
- **Supports Data Rates Up To 120 kbit/s**
- **ESD Protection Meets or Exceeds 10 kV on RS-232 Pins and 3.5 kV on All Other Pins (Human-Body Model)**
- **Pin-to-Pin Compatible With the SN75C185**

**DB, DW, OR N PACKAGE  
(TOP VIEW)**

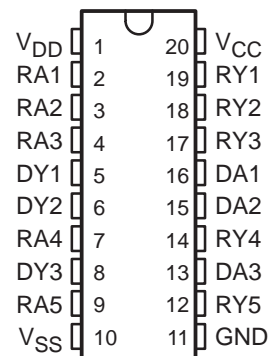

## description/ordering information

The SN75185 combines three drivers and five receivers from the TI SN75188 and SN75189 bipolar quadruple drivers and receivers, respectively. The pinout matches the flow-through design of the SN75C185 to decrease the part count, reduce the board space required, and allow easy interconnection of the UART and serial-port connector of IBM™ PC/AT™ and compatibles. The bipolar circuits and processing of the SN75185 provide a rugged low-cost solution for this function at the expense of quiescent power and external passive components relative to the SN75C185.

The SN75185 complies with the requirements of the TIA/EIA-232-F and ITU v.28 standards. These standards are for data interchange between a host computer and peripheral at signaling rates up to 20 kbit/s. The switching speeds of the SN75185 are fast enough to support rates up to 120 kbit/s with lower capacitive loads (shorter cables). Interoperability at the higher signaling rates cannot be assured unless the designer has design control of the cable and the interface circuits at both ends. For interoperability at signaling rates to 120 kbit/s, use of TIA/EIA-423-B (ITU v.10) and TIA/EIA-422-B (ITU v.11) standards is recommended.

The SN75185 is characterized for operation over the temperature range of 0°C to 70°C.

## ORDERING INFORMATION

T <sub>A</sub>	PACKAGE†		ORDERABLE PART NUMBER	TOP-SIDE MARKING
0°C to 70°C	PDIP (N)	Tube of 20	SN75185N	SN75185N
		Tube of 25	SN75185DW	SN75185
	SOIC (DW)	Reel of 2000	SN75185DWR	
		Tube of 70	SN75185DB	A185
	SSOP (DB)	Reel of 2000	SN75185DBR	

† Package drawings, standard packing quantities, thermal data, symbolization, and PCB design guidelines are available at [www.ti.com/sc/package](http://www.ti.com/sc/package).



Please be aware that an important notice concerning availability, standard warranty, and use in critical applications of Texas Instruments semiconductor products and disclaimers thereto appears at the end of this data sheet.

IBM and PC/AT are trademarks of IBM Corporation.

PRODUCTION DATA information is current as of publication date. Products conform to specifications per the terms of Texas Instruments standard warranty. Production processing does not necessarily include testing of all parameters.



Copyright © 2003, Texas Instruments Incorporated

# SN75185 MULTIPLE RS-232 DRIVERS AND RECEIVERS

SLLS181C – DECEMBER 1994 – REVISED OCTOBER 2003

## logic diagram (positive logic)

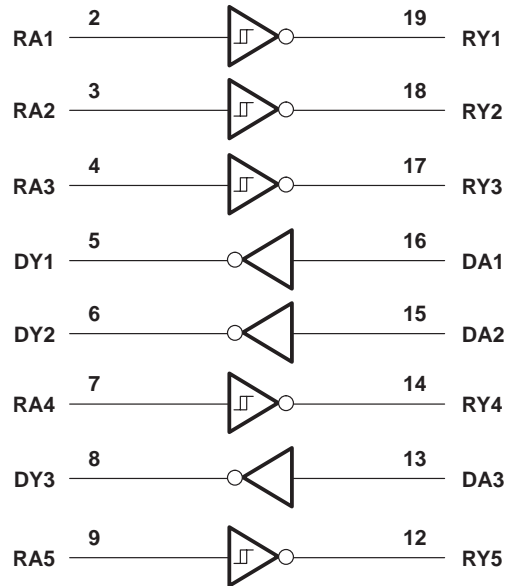

## schematic of drivers

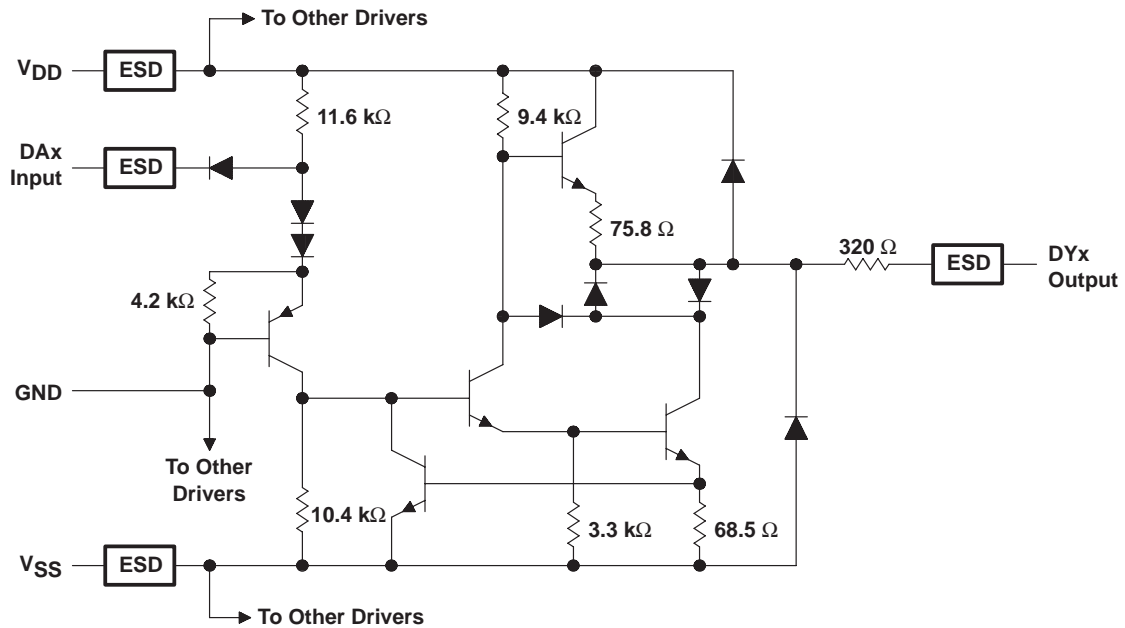

Resistor values shown are nominal.

**schematic (each receiver)**

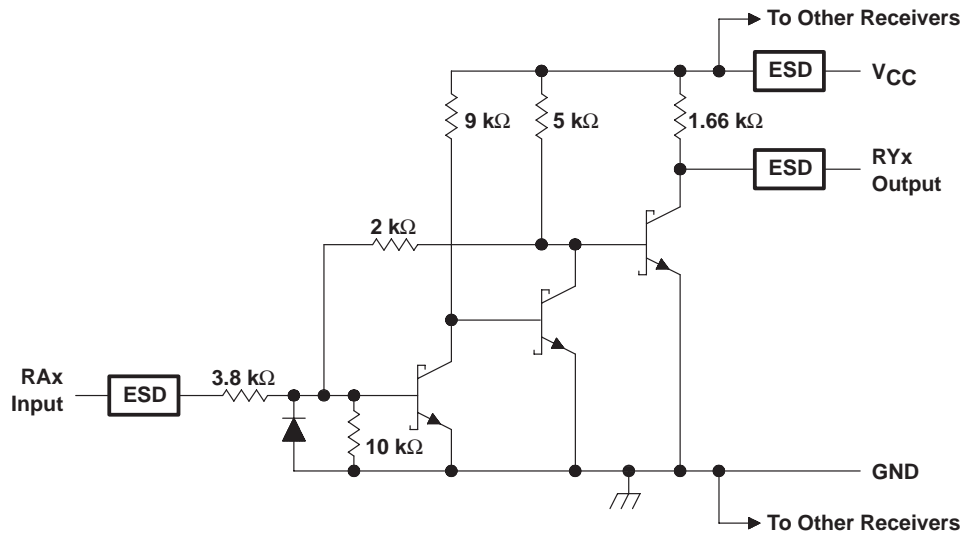

Resistor values shown are nominal.

**absolute maximum ratings over operating free-air temperature range (unless otherwise noted)†**

Supply voltage (see Note 1): $V_{CC}$ .....	10 V
$V_{DD}$ .....	15 V
$V_{SS}$ .....	-15 V
Input voltage range: Driver .....	-15 V to 7 V
Receiver .....	-30 V to 30 V
Driver output voltage range .....	-15 V to 15 V
Receiver low-level output current .....	20 mA
Package thermal impedance, $\theta_{JA}$ (see Notes 2 and 3): DB package .....	70°C/W
DW package .....	58°C/W
N package .....	69°C/W
Operating virtual junction temperature, $T_J$ .....	150°C
Electrostatic discharge: Human-Body Model: RS-232 pins, class 3, A (see Note 4) .....	10 kV
All pins, class 3, A (see Note 5) .....	3.5 kV
Machine Model: RS-232 pins, class 3, B (see Note 6) .....	600 V
All pins, class 3, B (see Note 4) .....	250 V
Storage temperature range, $T_{Stg}$ .....	-65°C to 150°C

† Stresses beyond those listed under “absolute maximum ratings” may cause permanent damage to the device. These are stress ratings only, and functional operation of the device at these or any other conditions beyond those indicated under “recommended operating conditions” is not implied. Exposure to absolute-maximum-rated conditions for extended periods may affect device reliability.

- NOTES:
1. All voltages are with respect to the network ground terminal.
  2. Maximum power dissipation is a function of  $T_J(\text{max})$ ,  $\theta_{JA}$ , and  $T_A$ . The maximum allowable power dissipation at any allowable ambient temperature is  $P_D = (T_J(\text{max}) - T_A)/\theta_{JA}$ . Operating at the absolute maximum  $T_J$  of 150°C can affect reliability.
  3. The package thermal impedance is calculated in accordance with JESD 51-7.
  4. RS-232 pins are tested with respect to ground and to each other.
  5. Per MIL-PRF-38535
  6. RS-232 pins are tested with respect to ground.

# SN75185 MULTIPLE RS-232 DRIVERS AND RECEIVERS

SLLS181C – DECEMBER 1994 – REVISED OCTOBER 2003

## recommended operating conditions

		MIN	NOM	MAX	UNIT
$V_{CC}$	Supply voltage	4.5	5	5.5	V
$V_{DD}$	Supply voltage	7.5	9	15	V
$V_{SS}$	Supply voltage	-7.5	-9	-15	V
$V_{IH}$	High-level input voltage (drivers only)	1.9			V
$V_{IL}$	Low-level input voltage (drivers only)			0.8	V
$I_{OH}$	High-level output current	Drivers		-6	mA
		Receivers		-0.5	
$I_{OL}$	Low-level output current	Drivers		6	mA
		Receivers		16	
$T_A$	Operating free-air temperature	0		70	°C

## supply currents

PARAMETER		TEST CONDITIONS		MIN	MAX	UNIT
$I_{CC}$	Supply current from $V_{CC}$	All inputs at 5 V,	No load, $V_{CC} = 5\text{ V}$		30	mA
$I_{DD}$	Supply current from $V_{DD}$	All inputs at 1.9 V,	No load	$V_{DD} = 9\text{ V}, V_{SS} = -9\text{ V}$	15	mA
				$V_{DD} = 12\text{ V}, V_{SS} = -12\text{ V}$	19	
				$V_{DD} = 15\text{ V}, V_{SS} = -15\text{ V}$	25	
		All inputs at 0.8 V,	No load	$V_{DD} = 9\text{ V}, V_{SS} = -9\text{ V}$	4.5	
				$V_{DD} = 12\text{ V}, V_{SS} = -12\text{ V}$	5.5	
				$V_{DD} = 15\text{ V}, V_{SS} = -15\text{ V}$	9	
$I_{SS}$	Supply current from $V_{SS}$	All inputs at 1.9 V,	No load	$V_{DD} = 9\text{ V}, V_{SS} = -9\text{ V}$	-15	mA
				$V_{DD} = 12\text{ V}, V_{SS} = -12\text{ V}$	-19	
				$V_{DD} = 15\text{ V}, V_{SS} = -15\text{ V}$	-25	
		All inputs at 0.8 V,	No load	$V_{DD} = 9\text{ V}, V_{SS} = -9\text{ V}$	-3.2	
				$V_{DD} = 12\text{ V}, V_{SS} = -12\text{ V}$	-3.2	
				$V_{DD} = 15\text{ V}, V_{SS} = -15\text{ V}$	-3.2	



**DRIVER SECTION**

**electrical characteristics over recommended operating free-air temperature range,  $V_{DD} = 9\text{ V}$ ,  $V_{SS} = -9\text{ V}$ ,  $V_{CC} = 5\text{ V}$  (unless otherwise noted)**

PARAMETER		TEST CONDITIONS			MIN	TYP	MAX	UNIT
$V_{OH}$	High-level output voltage	$V_{IL} = 0.8\text{ V}$ ,	$R_L = 3\text{ k}\Omega$ ,	See Figure 1	6	7.5		V
$V_{OL}$	Low-level output voltage (see Note 7)	$V_{IH} = 1.9\text{ V}$ ,	$R_L = 3\text{ k}\Omega$ ,	See Figure 1		-7.5	-6	V
$I_{IH}$	High-level input current	$V_I = 5\text{ V}$ ,	See Figure 2				10	$\mu\text{A}$
$I_{IL}$	Low-level input current	$V_I = 0$ ,	See Figure 2				-1.6	mA
$I_{OS(H)}$	High-level short-circuit output current (see Note 8)	$V_{IL} = 0.8\text{ V}$ ,	$V_O = 0$ ,	See Figure 1	-4.5	-12	-19.5	mA
$I_{OS(L)}$	Low-level short-circuit output current	$V_{IH} = 2\text{ V}$ ,	$V_O = 0$ ,	See Figure 1	4.5	12	19.5	mA
$r_o$	Output resistance (see Note 9)	$V_{CC} = V_{DD} = V_{SS} = 0$ ,		$V_O = -2\text{ V to } 2\text{ V}$	300			$\Omega$

- NOTES: 7. The algebraic convention, in which the more positive (less negative) limit is designated as maximum, is used in this data sheet for logic levels only (e.g., if  $-10\text{ V}$  is maximum, the typical value is a more negative voltage).  
 8. Output short-circuit conditions must maintain the total power dissipation below absolute maximum ratings.  
 9. Test conditions are those specified by TIA/EIA-232-F and as listed above.

**switching characteristics,  $V_{CC} = 5\text{ V}$ ,  $V_{DD} = 12\text{ V}$ ,  $V_{SS} = -12\text{ V}$ ,  $T_A = 25^\circ\text{C}$  (see Figure 3)**

PARAMETER		TEST CONDITIONS		MIN	TYP	MAX	UNIT
$t_{PLH}$	Propagation delay time, low- to high-level output	$R_L = 3\text{ k}\Omega$ to $7\text{ k}\Omega$ ,	$C_L = 15\text{ pF}$		315	500	ns
$t_{PHL}$	Propagation delay time, high- to low-level output	$R_L = 3\text{ k}\Omega$ to $7\text{ k}\Omega$ ,	$C_L = 15\text{ pF}$		75	175	ns
$t_{TLH}$	Transition time, low- to high-level output	$R_L = 3\text{ k}\Omega$ to $7\text{ k}\Omega$	$C_L = 15\text{ pF}$		60	100	ns
			$C_L = 2500\text{ pF}$ , See Note 10		1.7	2.5	$\mu\text{s}$
$t_{THL}$	Transition time, high- to low-level output	$R_L = 3\text{ k}\Omega$ to $7\text{ k}\Omega$	$C_L = 15\text{ pF}$		40	75	ns
			$C_L = 2500\text{ pF}$ , See Note 11		1.5	2.5	$\mu\text{s}$

- NOTES: 10. Measured between  $-3\text{-V}$  and  $3\text{-V}$  points of the output waveform (TIA/EIA-232-F conditions); all unused inputs are tied either high or low.  
 11. Measured between  $3\text{-V}$  and  $-3\text{-V}$  points of the output waveform (TIA/EIA-232-F conditions); all unused inputs are tied either high or low.

# SN75185 MULTIPLE RS-232 DRIVERS AND RECEIVERS

SLLS181C – DECEMBER 1994 – REVISED OCTOBER 2003

## RECEIVER SECTION

electrical characteristics over recommended operating conditions (unless otherwise noted)

PARAMETER	TEST CONDITIONS		MIN	TYP†	MAX	UNIT
$V_{T+}$ Positive-going threshold voltage	See Figure 5	$T_A = 25^\circ\text{C}$	1.75	1.9	2.3	V
		$T_A = 0^\circ\text{C to } 70^\circ\text{C}$	1.55		2.3	
$V_{T-}$ Negative-going threshold voltage			0.75	0.97	1.25	
$V_{hys}$ Input hysteresis ( $V_{T+} - V_{T-}$ )			0.5			
$V_{OH}$ High-level output voltage	$I_{OH} = -0.5\text{ mA}$	$V_{IH} = 0.75\text{ V}$	2.6	4	5	V
		Inputs open	2.6			
$V_{OL}$ Low-level output voltage	$I_{OL} = 10\text{ mA}$ ,	$V_I = 3\text{ V}$		0.2	0.45	V
$I_{IH}$ High-level input current	$V_I = 25\text{ V}$ ,	See Figure 5	3.6		8.3	mA
	$V_I = 3\text{ V}$ ,	See Figure 5	0.43			
$I_{IL}$ Low-level output current	$V_I = -25\text{ V}$ ,	See Figure 5	-3.6		-8.3	mA
	$V_I = -3\text{ V}$ ,	See Figure 5	-0.43			
$I_{OS}$ Short-circuit output current	See Figure 4			-3.4	-12	mA

† All typical values are at  $T_A = 25^\circ\text{C}$ ,  $V_{CC} = 5\text{ V}$ ,  $V_{DD} = 9\text{ V}$ , and  $V_{SS} = -9\text{ V}$ .

switching characteristics,  $V_{CC} = 5\text{ V}$ ,  $V_{DD} = 12\text{ V}$ ,  $V_{SS} = -12\text{ V}$ ,  $T_A = 25^\circ\text{C}$  (see Figure 6)

PARAMETER	TEST CONDITIONS		MIN	TYP	MAX	UNIT
$t_{PLH}$ Propagation delay time, low- to high-level output	$C_L = 50\text{ pF}$ ,	$R_L = 5\text{ k}\Omega$		107	500	ns
$t_{PHL}$ Propagation delay time, high- to low-level output	$C_L = 50\text{ pF}$ ,	$R_L = 5\text{ k}\Omega$		42	150	ns
$t_{TLH}$ Transition time, low- to high-level output	$C_L = 50\text{ pF}$ ,	$R_L = 5\text{ k}\Omega$		175	525	ns
$t_{THL}$ Transition time, high- to low-level output	$C_L = 50\text{ pF}$ ,	$R_L = 5\text{ k}\Omega$		16	60	ns

## PARAMETER MEASUREMENT INFORMATION

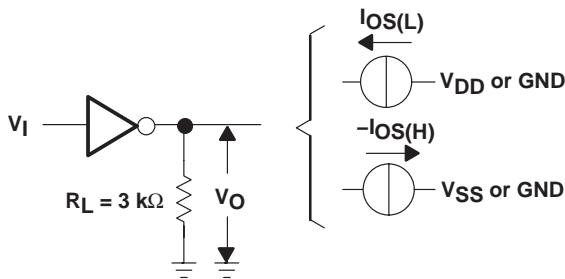

Figure 1. Driver Test Circuit for  $V_{OH}$ ,  $V_{OL}$ ,  $I_{OS(H)}$ , and  $I_{OS(L)}$

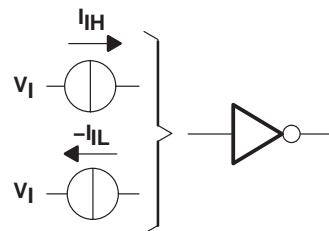
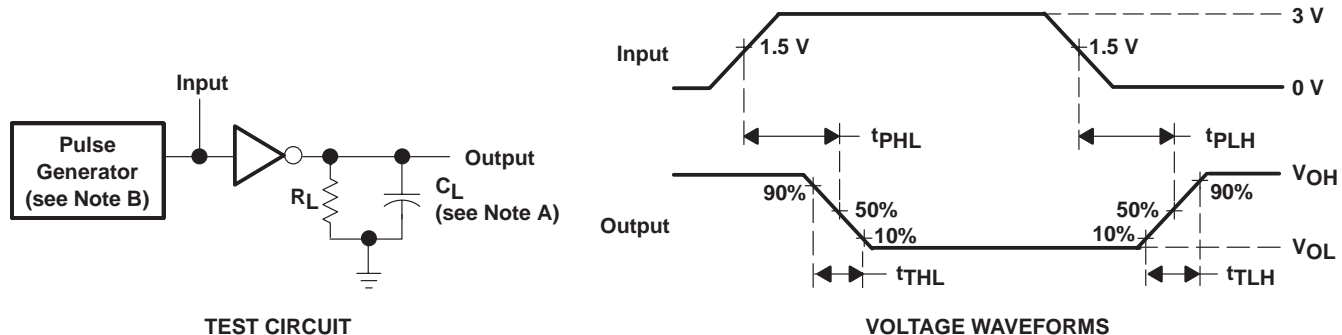

Figure 2. Driver Test Circuit for  $I_{IH}$  and  $I_{IL}$

PARAMETER MEASUREMENT INFORMATION



NOTES: A.  $C_L$  includes probe and jig capacitance.  
 B. The pulse generator has the following characteristics:  $t_w = 25 \mu s$ ,  $PRR = 20 \text{ kHz}$ ,  $Z_O = 50 \Omega$ ,  $t_r = t_f < 50 \text{ ns}$ .

Figure 3. Driver Test Circuit and Voltage Waveforms

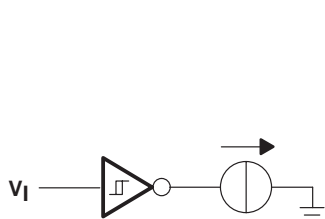

Figure 4. Receiver Test Circuit for  $I_{OS}$

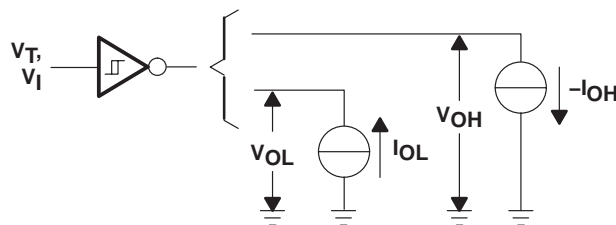
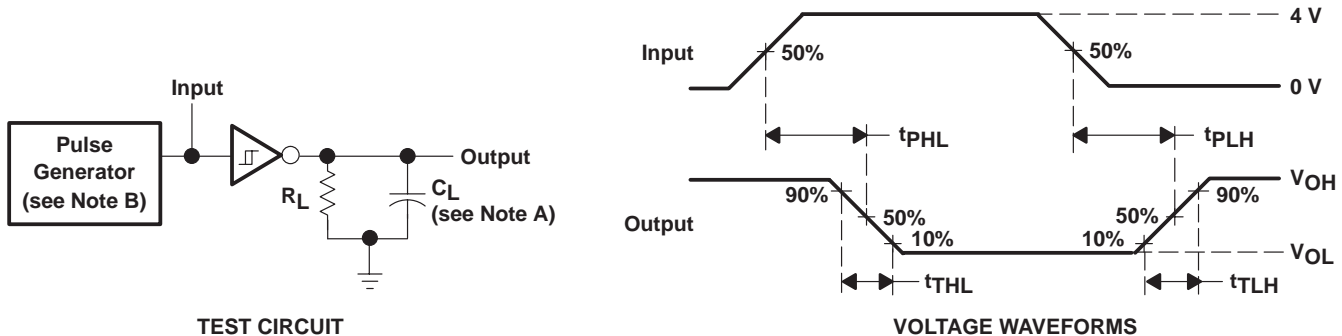

Figure 5. Receiver Test Circuit for  $V_T$ ,  $V_{OH}$ , and  $V_{OL}$



NOTES: A.  $C_L$  includes probe and jig capacitance.  
 B. The pulse generator has the following characteristics:  $t_w = 25 \mu s$ ,  $PRR = 20 \text{ kHz}$ ,  $Z_O = 50 \Omega$ ,  $t_r = t_f < 50 \text{ ns}$ .

Figure 6. Receiver Propagation and Transition Times

# SN75185 MULTIPLE RS-232 DRIVERS AND RECEIVERS

SLLS181C – DECEMBER 1994 – REVISED OCTOBER 2003

## TYPICAL CHARACTERISTICS

### DRIVER SECTION

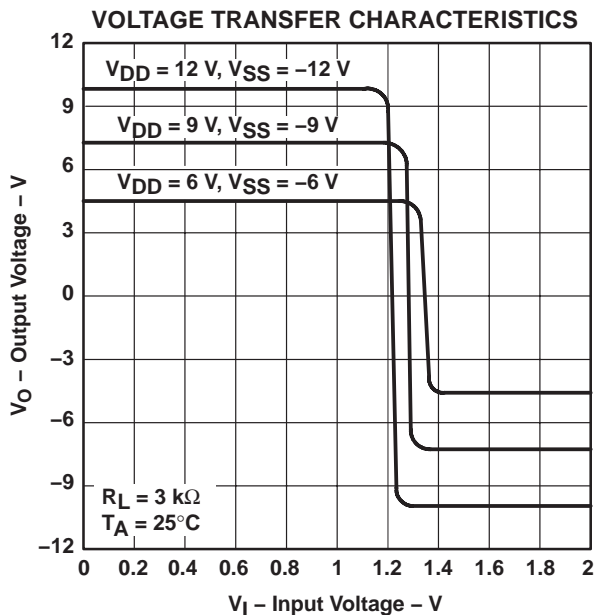

Figure 7

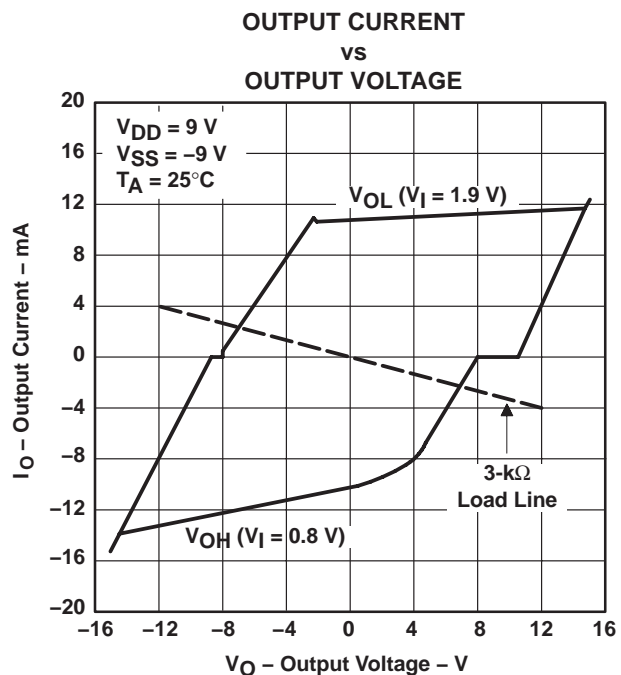

Figure 8

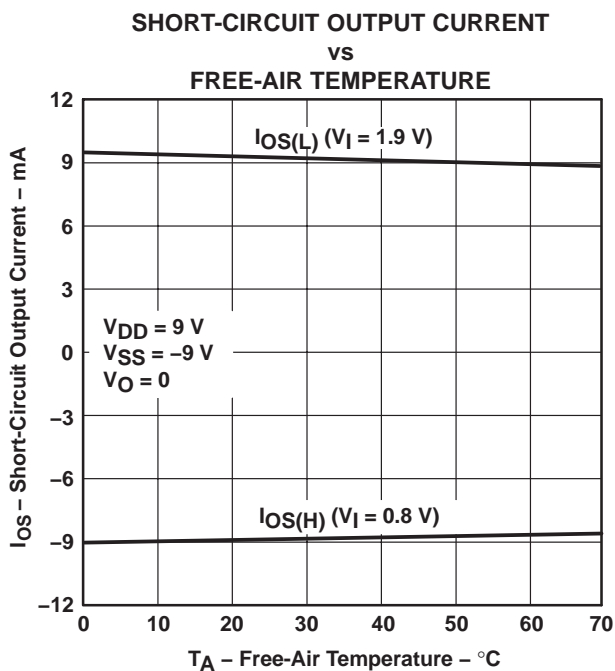

Figure 9

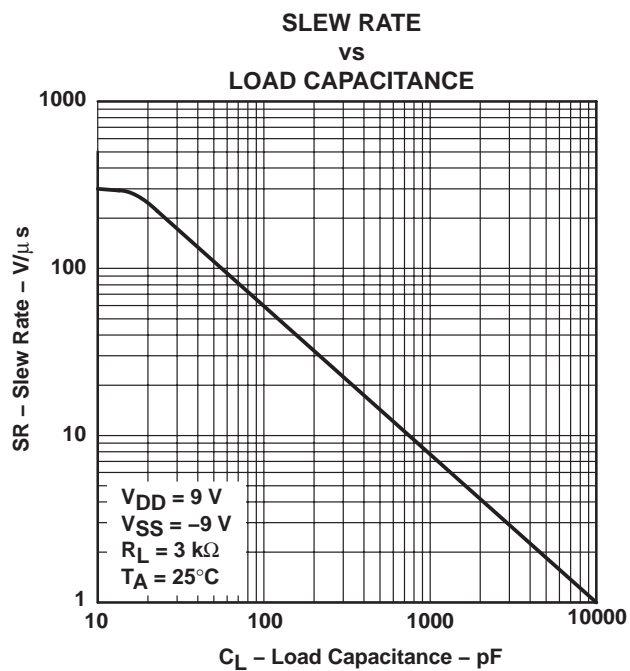

Figure 10



TYPICAL CHARACTERISTICS

RECEIVER SECTION

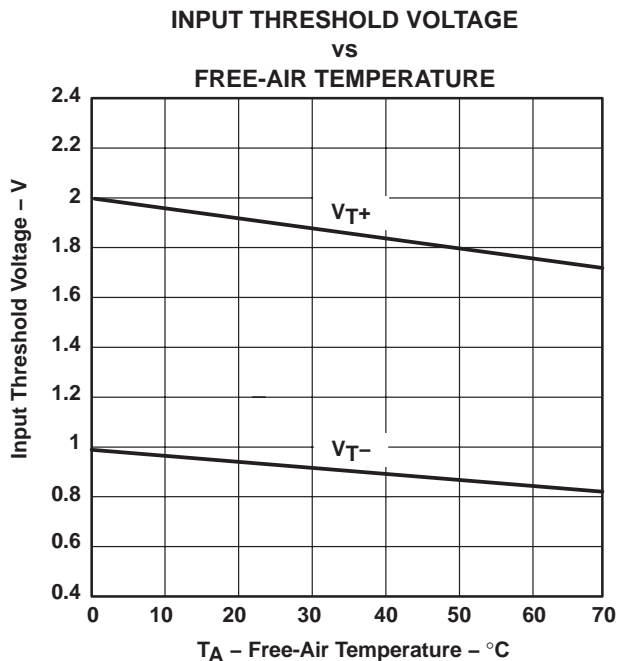

Figure 11

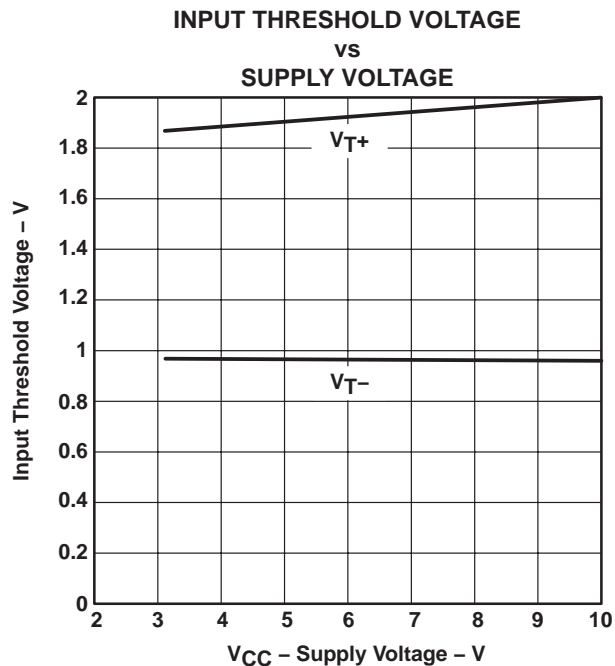
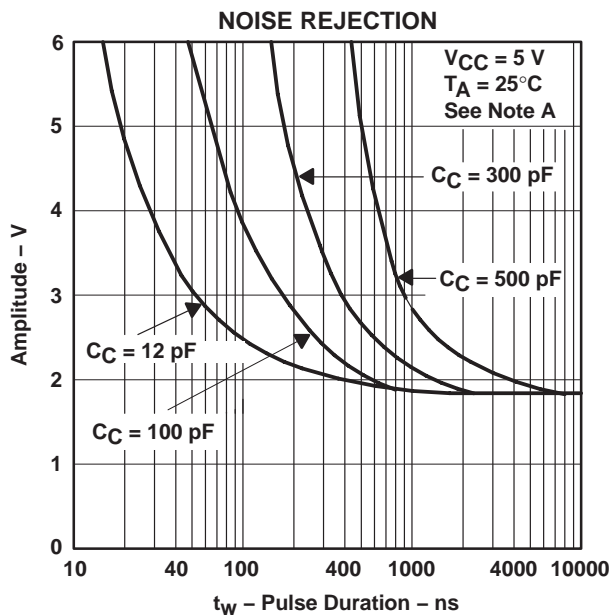

Figure 12



NOTE A: This figure shows the maximum amplitude of a positive-going pulse that, starting from 0 V, will not cause a change in the output level.

Figure 13

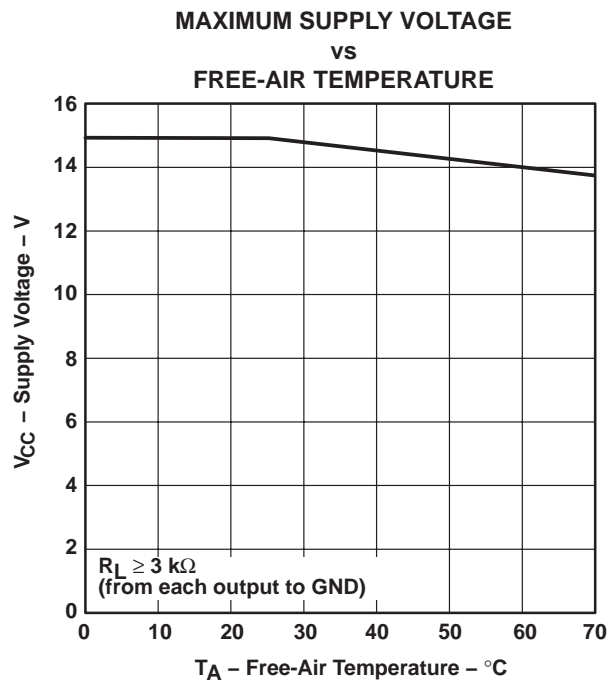

Figure 14

# SN75185 MULTIPLE RS-232 DRIVERS AND RECEIVERS

SLLS181C – DECEMBER 1994 – REVISED OCTOBER 2003

## APPLICATION INFORMATION

Diodes placed in series with the  $V_{DD}$  and  $V_{SS}$  leads protect the SN75185 in the fault condition. In the fault condition, the device outputs are shorted to  $\pm 15$  V, and the power supplies are at low and provide low-impedance paths to ground (see Figure 15).

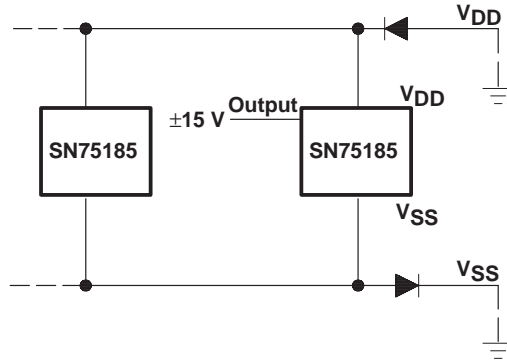
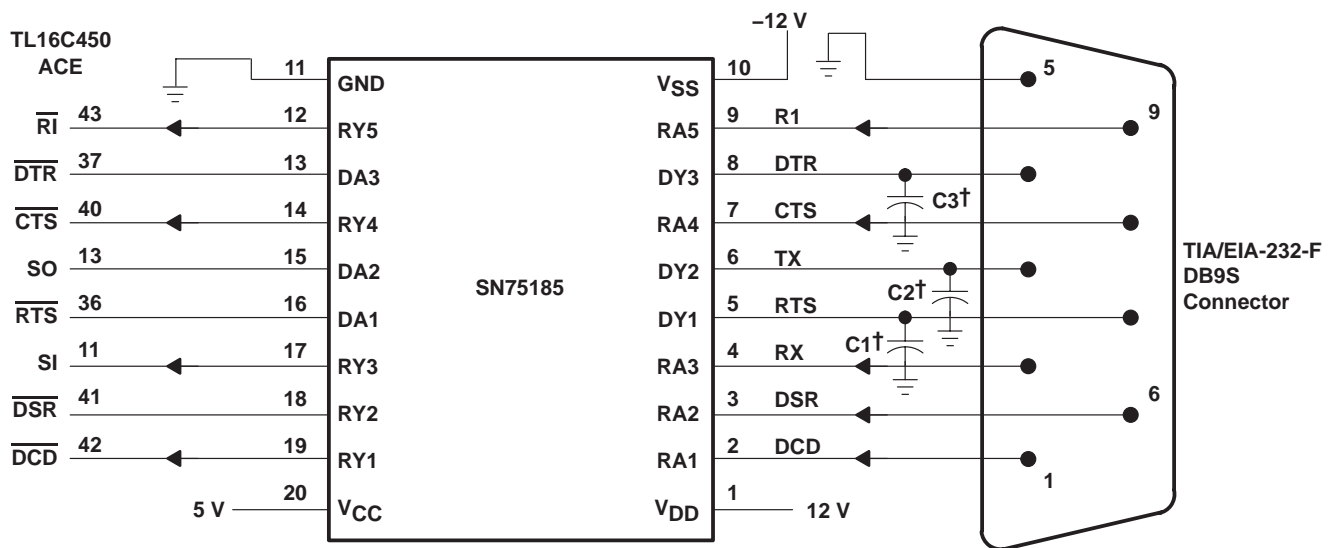

Figure 15. Power-Supply Protection to Meet Power-Off Fault Conditions of TIA/EIA-232-F



† See Figure 10 to select the correct values for the loading capacitors ( $C_1$ ,  $C_2$ , and  $C_3$ ), which are required to meet the RS-232 maximum slew-rate requirement of  $30 \text{ V}/\mu\text{s}$ . The value of the loading capacitors required depends on the line length and desired slew rate, but typically is  $330 \text{ pF}$ .

Figure 16. Typical Connection

**PACKAGING INFORMATION**

Orderable Device	Status <sup>(1)</sup>	Package Type	Package Drawing	Pins	Package Qty	Eco Plan <sup>(2)</sup>	Lead/Ball Finish	MSL Peak Temp <sup>(3)</sup>
SN75185DB	ACTIVE	SSOP	DB	20	70	Pb-Free (RoHS)	CU NIPDAU	Level-2-260C-1 YEAR/ Level-1-235C-UNLIM
SN75185DBR	ACTIVE	SSOP	DB	20	2000	Pb-Free (RoHS)	CU NIPDAU	Level-2-260C-1 YEAR/ Level-1-235C-UNLIM
SN75185DW	ACTIVE	SOIC	DW	20	25	Pb-Free (RoHS)	CU NIPDAU	Level-2-250C-1 YEAR/ Level-1-235C-UNLIM
SN75185DWR	ACTIVE	SOIC	DW	20	2000	Pb-Free (RoHS)	CU NIPDAU	Level-2-250C-1 YEAR/ Level-1-235C-UNLIM
SN75185N	ACTIVE	PDIP	N	20	20	Pb-Free (RoHS)	CU NIPDAU	Level-NC-NC-NC

<sup>(1)</sup> The marketing status values are defined as follows:

**ACTIVE:** Product device recommended for new designs.

**LIFEBUY:** TI has announced that the device will be discontinued, and a lifetime-buy period is in effect.

**NRND:** Not recommended for new designs. Device is in production to support existing customers, but TI does not recommend using this part in a new design.

**PREVIEW:** Device has been announced but is not in production. Samples may or may not be available.

**OBSOLETE:** TI has discontinued the production of the device.

<sup>(2)</sup> Eco Plan - May not be currently available - please check <http://www.ti.com/productcontent> for the latest availability information and additional product content details.

**None:** Not yet available Lead (Pb-Free).

**Pb-Free (RoHS):** TI's terms "Lead-Free" or "Pb-Free" mean semiconductor products that are compatible with the current RoHS requirements for all 6 substances, including the requirement that lead not exceed 0.1% by weight in homogeneous materials. Where designed to be soldered at high temperatures, TI Pb-Free products are suitable for use in specified lead-free processes.

**Green (RoHS & no Sb/Br):** TI defines "Green" to mean "Pb-Free" and in addition, uses package materials that do not contain halogens, including bromine (Br) or antimony (Sb) above 0.1% of total product weight.

<sup>(3)</sup> MSL, Peak Temp. -- The Moisture Sensitivity Level rating according to the JEDEC industry standard classifications, and peak solder temperature.

**Important Information and Disclaimer:** The information provided on this page represents TI's knowledge and belief as of the date that it is provided. TI bases its knowledge and belief on information provided by third parties, and makes no representation or warranty as to the accuracy of such information. Efforts are underway to better integrate information from third parties. TI has taken and continues to take reasonable steps to provide representative and accurate information but may not have conducted destructive testing or chemical analysis on incoming materials and chemicals. TI and TI suppliers consider certain information to be proprietary, and thus CAS numbers and other limited information may not be available for release.

In no event shall TI's liability arising out of such information exceed the total purchase price of the TI part(s) at issue in this document sold by TI to Customer on an annual basis.

N (R-PDIP-T\*\*)

PLASTIC DUAL-IN-LINE PACKAGE

16 PINS SHOWN

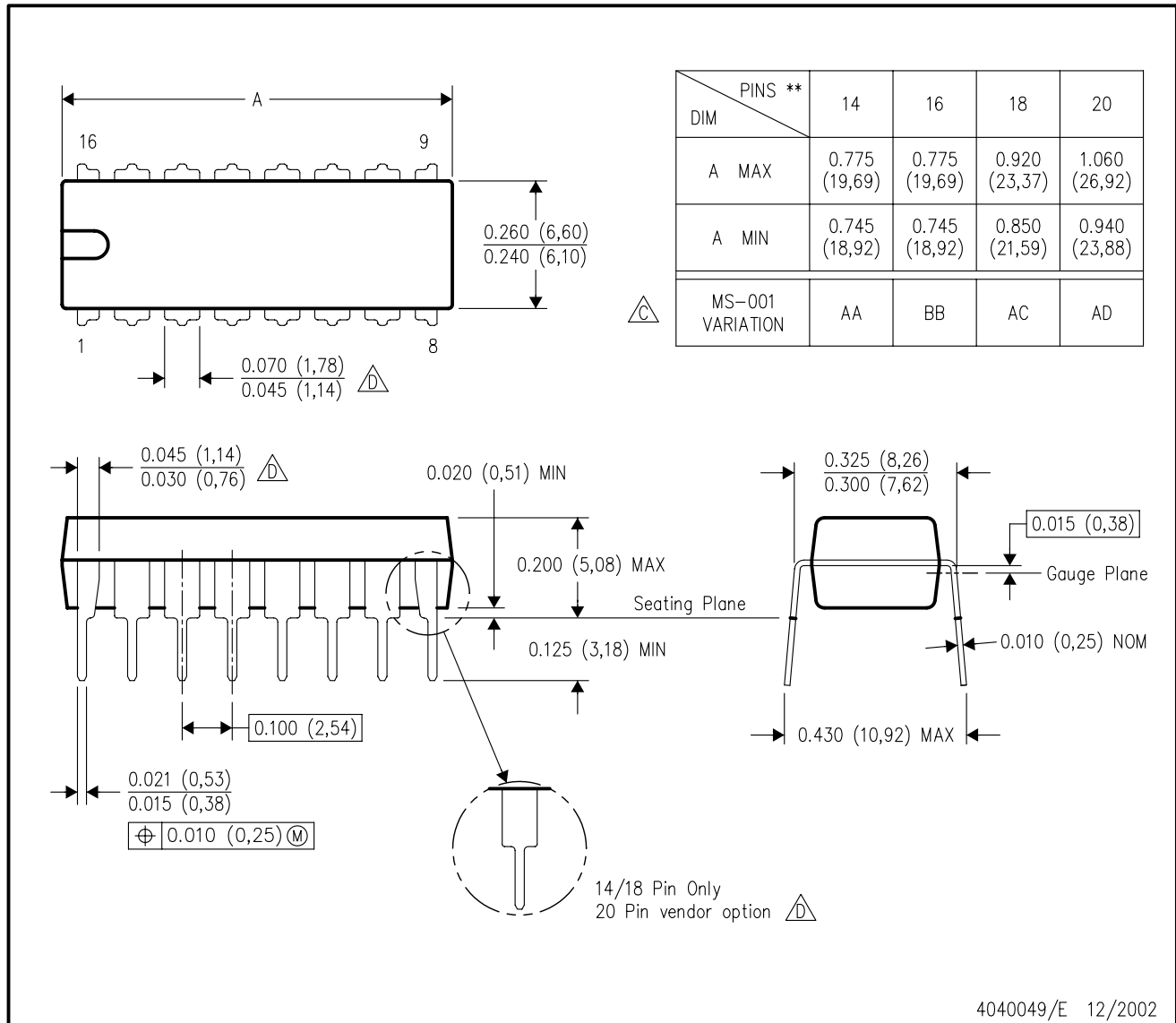

- NOTES:
- A. All linear dimensions are in inches (millimeters).
  - B. This drawing is subject to change without notice.
  - C Falls within JEDEC MS-001, except 18 and 20 pin minimum body length (Dim A).
  - D The 20 pin end lead shoulder width is a vendor option, either half or full width.

4040049/E 12/2002

DW (R-PDSO-G20)

PLASTIC SMALL-OUTLINE PACKAGE

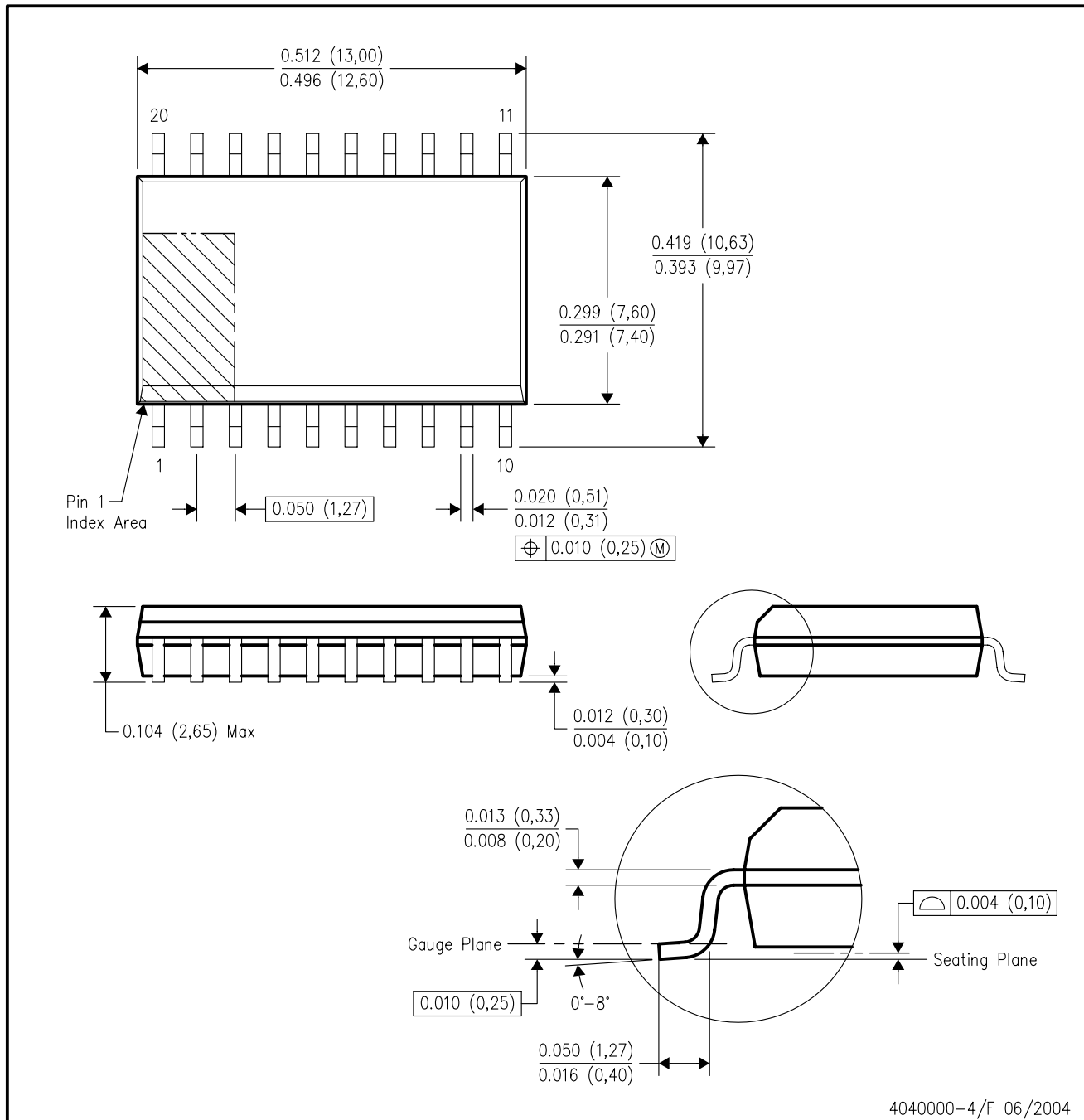

- NOTES:
- A. All linear dimensions are in inches (millimeters).
  - B. This drawing is subject to change without notice.
  - C. Body dimensions do not include mold flash or protrusion not to exceed 0.006 (0,15).
  - D. Falls within JEDEC MS-013 variation AC.

DB (R-PDSO-G\*\*)

PLASTIC SMALL-OUTLINE

28 PINS SHOWN

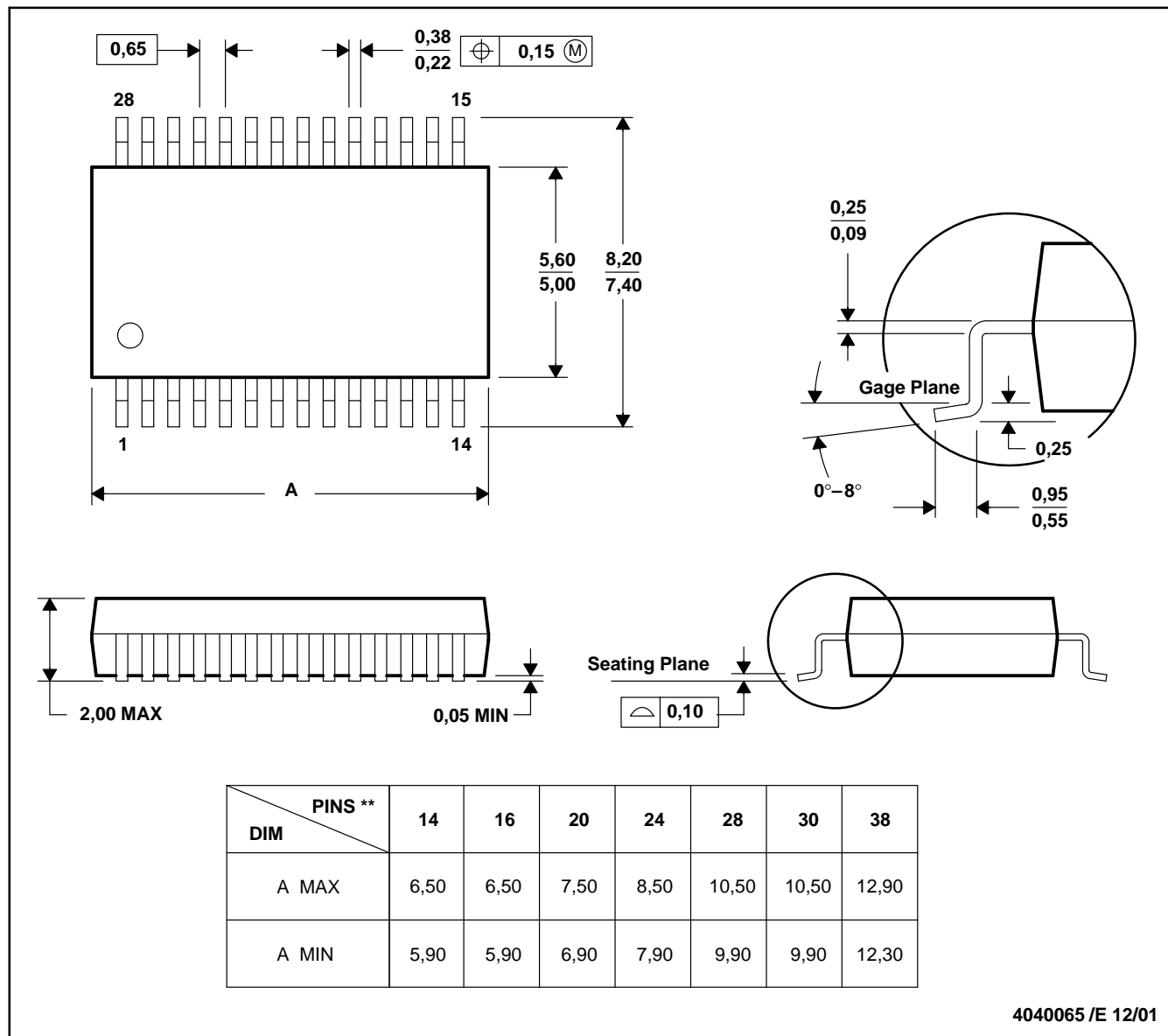

- NOTES: A. All linear dimensions are in millimeters.  
 B. This drawing is subject to change without notice.  
 C. Body dimensions do not include mold flash or protrusion not to exceed 0,15.  
 D. Falls within JEDEC MO-150

## IMPORTANT NOTICE

Texas Instruments Incorporated and its subsidiaries (TI) reserve the right to make corrections, modifications, enhancements, improvements, and other changes to its products and services at any time and to discontinue any product or service without notice. Customers should obtain the latest relevant information before placing orders and should verify that such information is current and complete. All products are sold subject to TI's terms and conditions of sale supplied at the time of order acknowledgment.

TI warrants performance of its hardware products to the specifications applicable at the time of sale in accordance with TI's standard warranty. Testing and other quality control techniques are used to the extent TI deems necessary to support this warranty. Except where mandated by government requirements, testing of all parameters of each product is not necessarily performed.

TI assumes no liability for applications assistance or customer product design. Customers are responsible for their products and applications using TI components. To minimize the risks associated with customer products and applications, customers should provide adequate design and operating safeguards.

TI does not warrant or represent that any license, either express or implied, is granted under any TI patent right, copyright, mask work right, or other TI intellectual property right relating to any combination, machine, or process in which TI products or services are used. Information published by TI regarding third-party products or services does not constitute a license from TI to use such products or services or a warranty or endorsement thereof. Use of such information may require a license from a third party under the patents or other intellectual property of the third party, or a license from TI under the patents or other intellectual property of TI.

Reproduction of information in TI data books or data sheets is permissible only if reproduction is without alteration and is accompanied by all associated warranties, conditions, limitations, and notices. Reproduction of this information with alteration is an unfair and deceptive business practice. TI is not responsible or liable for such altered documentation.

Resale of TI products or services with statements different from or beyond the parameters stated by TI for that product or service voids all express and any implied warranties for the associated TI product or service and is an unfair and deceptive business practice. TI is not responsible or liable for any such statements.

Following are URLs where you can obtain information on other Texas Instruments products and application solutions:

<b>Products</b>		<b>Applications</b>	
Amplifiers	<a href="http://amplifier.ti.com">amplifier.ti.com</a>	Audio	<a href="http://www.ti.com/audio">www.ti.com/audio</a>
Data Converters	<a href="http://dataconverter.ti.com">dataconverter.ti.com</a>	Automotive	<a href="http://www.ti.com/automotive">www.ti.com/automotive</a>
DSP	<a href="http://dsp.ti.com">dsp.ti.com</a>	Broadband	<a href="http://www.ti.com/broadband">www.ti.com/broadband</a>
Interface	<a href="http://interface.ti.com">interface.ti.com</a>	Digital Control	<a href="http://www.ti.com/digitalcontrol">www.ti.com/digitalcontrol</a>
Logic	<a href="http://logic.ti.com">logic.ti.com</a>	Military	<a href="http://www.ti.com/military">www.ti.com/military</a>
Power Mgmt	<a href="http://power.ti.com">power.ti.com</a>	Optical Networking	<a href="http://www.ti.com/opticalnetwork">www.ti.com/opticalnetwork</a>
Microcontrollers	<a href="http://microcontroller.ti.com">microcontroller.ti.com</a>	Security	<a href="http://www.ti.com/security">www.ti.com/security</a>
		Telephony	<a href="http://www.ti.com/telephony">www.ti.com/telephony</a>
		Video & Imaging	<a href="http://www.ti.com/video">www.ti.com/video</a>
		Wireless	<a href="http://www.ti.com/wireless">www.ti.com/wireless</a>

Mailing Address: Texas Instruments  
Post Office Box 655303 Dallas, Texas 75265