

SN55115, SN75115 DUAL DIFFERENTIAL RECEIVERS

SLLS072D – SEPTEMBER 1973 – REVISED MAY 1998

- Choice of Open-Collector or Active Pullup (Totem-Pole) Outputs
- Single 5-V Supply
- Differential Line Operation
- Dual-Channel Operation
- TTL Compatible
- ± 15 -V Common-Mode Input Voltage Range
- Optional-Use Built-In 130- Ω Line-Terminating Resistor
- Individual Frequency-Response Controls
- Individual Channel Strobes
- Designed for Use With SN55113, SN75113, SN55114, and SN75114 Drivers
- Designed to Be Interchangeable With National DS9615 Line Receivers

description

The SN55115 and SN75115 dual differential line receivers are designed to sense small differential signals in the presence of large common-mode noise. These devices give TTL-compatible output signals as a function of the differential input voltage. The open-collector output configuration permits the wire-ANDing of similar TTL outputs (such as SN5401/SN7401) or other SN55115/SN75115 line receivers. This permits a level of logic to be implemented without extra delay.

The output stages are similar to TTL totem-pole outputs, but with sink outputs, 1YS and 2YS, and the corresponding active pullup terminals, 1YP and 2YP, available on adjacent package pins. The frequency response and noise immunity may be provided by a single external capacitor. A strobe input is provided for each channel. With the strobe in the low level, the receiver is disabled and the outputs are forced to a high level.

The SN55115 is characterized for operation over the full military temperature range of -55°C to 125°C . The SN75115 is characterized for operation from 0°C to 70°C .

SN55115 . . . J OR W PACKAGE
SN75115 . . . N PACKAGE
(TOP VIEW)

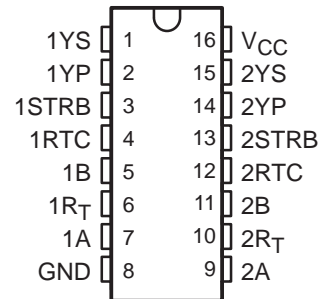

SN55114 . . . FK PACKAGE
(TOP VIEW)

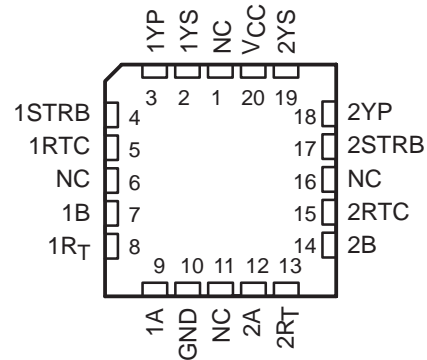

NC – No internal connection

FUNCTION TABLE

STRB	DIFF INPUT (A AND B)	OUTPUT (YP AND YS TIED TOGETHER)
L	X	H
H	L	H
H	H	L

H = $V_I \geq V_{IH \text{ min}}$ or V_{ID} more positive than $V_{T+ \text{ max}}$
L = $V_I \leq V_{IL \text{ max}}$ or V_{ID} more negative than $V_{T- \text{ max}}$
X = irrelevant



Please be aware that an important notice concerning availability, standard warranty, and use in critical applications of Texas Instruments semiconductor products and disclaimers thereto appears at the end of this data sheet.

PRODUCTION DATA information is current as of publication date. Products conform to specifications per the terms of Texas Instruments standard warranty. Production processing does not necessarily include testing of all parameters.

 **TEXAS
INSTRUMENTS**

POST OFFICE BOX 655303 • DALLAS, TEXAS 75265

Copyright © 1998, Texas Instruments Incorporated

SN55115, SN75115 DUAL DIFFERENTIAL RECEIVERS

SLLS072D – SEPTEMBER 1973 – REVISED MAY 1998

logic symbol†

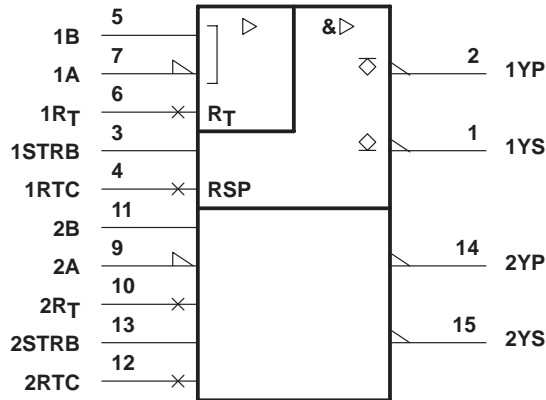

† This symbol is in accordance with ANSI/IEEE Std 91-1984 and IEC Publication 617-12.

logic diagram (positive logic)

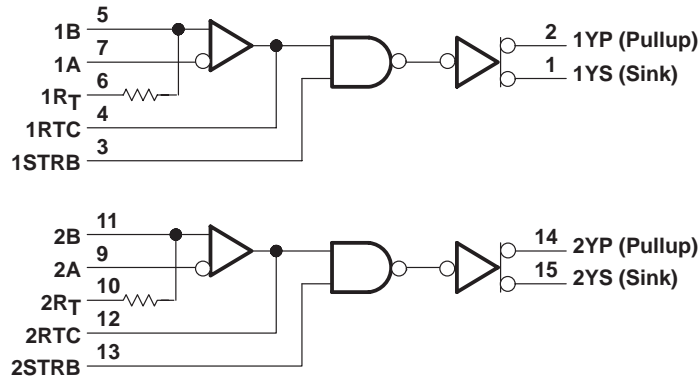

schematic (each receiver)

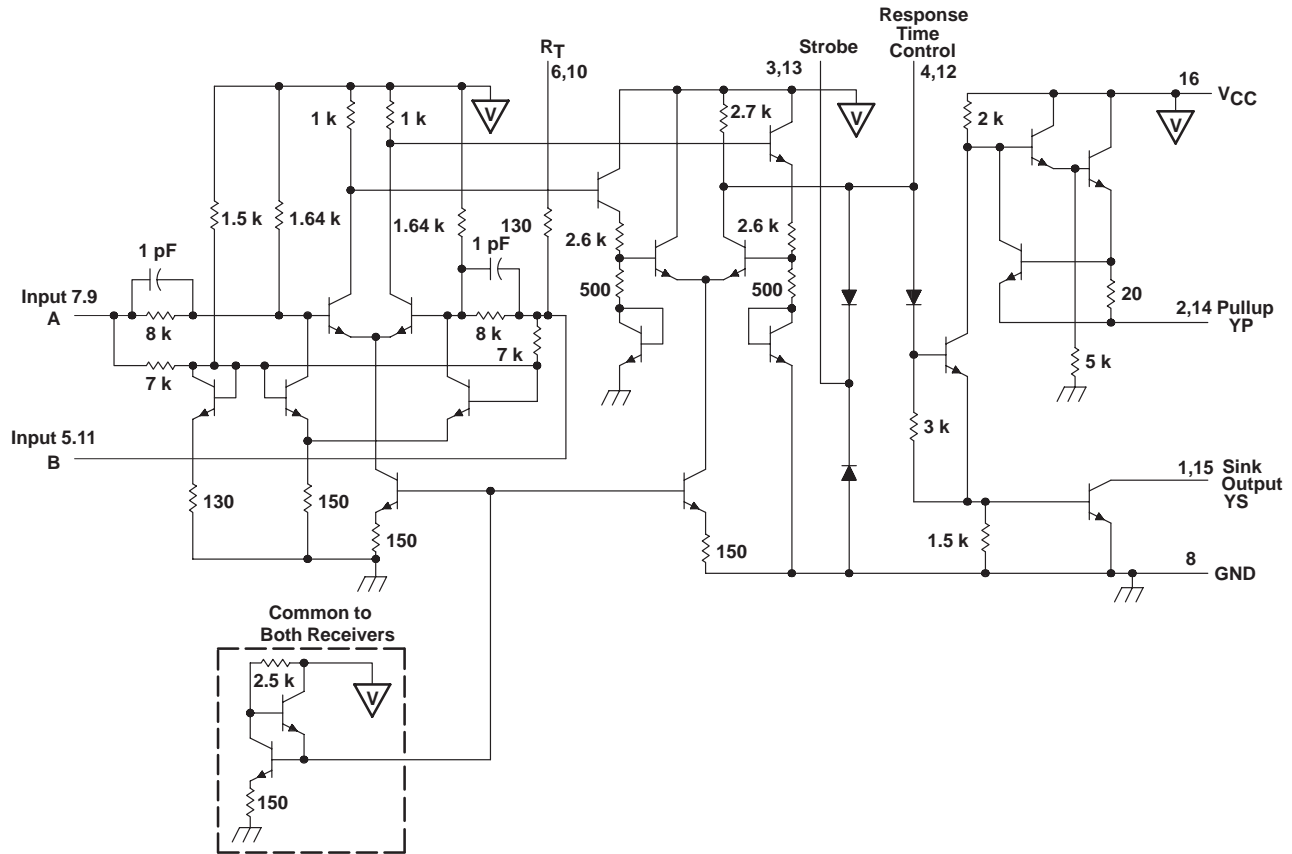

Resistor values are nominal and in ohms.
Pin numbers shown are for the J, N, and W packages.

absolute maximum ratings over operating free-air temperature range (unless otherwise noted)†

Supply voltage, V_{CC} (see Note 1)	7 V
Input voltage V_I (A, B, and R_T)	± 25 V
Input voltage V_I (STRB)	5.5 V
Off-state voltage applied to open-collector outputs	14 V
Continuous total power dissipation	See Dissipation Rating Table
Storage temperature range, T_{Stg}	-65°C to 150°C
Case temperature for 60 seconds: FK package	260°C
Lead temperature 1,6 mm (1/16 inch) from case for 60 seconds: J or W package	300°C
Lead temperature 1,6 mm (1/16 inch) from case for 10 seconds: N package	260°C

† Stresses beyond those listed under "absolute maximum ratings" may cause permanent damage to the device. These are stress ratings only, and functional operation of the device at these or any other conditions beyond those indicated under "recommended operating conditions" is not implied. Exposure to absolute-maximum-rated conditions for extended periods may affect device reliability.

NOTE 1: All voltage values, except differential input voltage, are with respect to network ground terminal.

SN55115, SN75115 DUAL DIFFERENTIAL RECEIVERS

SLLS072D – SEPTEMBER 1973 – REVISED MAY 1998

DISSIPATION RATING TABLE

PACKAGE	$T_A \leq 25^\circ\text{C}$ POWER RATING	DERATING FACTOR ABOVE $T_A = 25^\circ\text{C}$	$T_A = 70^\circ\text{C}$ POWER RATING	$T_A = 125^\circ\text{C}$ POWER RATING
FK†	1375 mW	11.0 mW/°C	880 mW	275 mW
J†	1375 mW	11.0 mW/°C	880 mW	275 mW
N	1150 mW	9.2 mW/°C	736 mW	—
W†	1000 mW	8.0 mW/°C	640 mW	200 mW

† In the FK, J, and W packages, SN55115 chips are either silver glass or alloy mounted. SN75115 chips are glass mounted.

recommended operating conditions

	SN55115			SN75115			UNIT
	MIN	NOM	MAX	MIN	NOM	MAX	
Supply voltage, V_{CC}	4.5	5	5.5	4.75	5	5.25	V
High-level input voltage at STRB, V_{IH}	2.4			2.4			V
Low-level input voltage at STRB, V_{IL}	0.4			0.4			V
High-level output current, I_{OH}	-5			-5			mA
Low-level output current, I_{OL}	15			15			mA
Operating free-air temperature, T_A	-55			125			°C



POST OFFICE BOX 655303 • DALLAS, TEXAS 75265

SN55115, SN75115 DUAL DIFFERENTIAL RECEIVERS

SLLS072D – SEPTEMBER 1973 – REVISED MAY 1998

electrical characteristics over recommended operating free-air temperature range (unless otherwise noted)

PARAMETER	TEST CONDITIONS†	SN55115			SN75115			UNIT	
		MIN	TYP‡	MAX	MIN	TYP‡	MAX		
V_{IT+} §	Positive-going threshold voltage $V_O = 0.4\text{ V}$, $I_{OL} = 15\text{ mA}$, $V_{IC} = 0$	500			500			mV	
V_{IT-} §	Negative-going threshold voltage $V_O = 2.4\text{ V}$, $I_{OH} = -5\text{ mA}$, $V_{IC} = 0$	-500¶			-500¶			mV	
V_{ICR}	Common-mode input voltage range $V_{ID} = \pm 1\text{ V}$	+15 to -15	+24 to -19		+15 to -15	+24 to -19		V	
V_{OH}	High-level output voltage $V_{CC} = \text{MIN}$, $I_{OH} = -5\text{ mA}$, $V_{ID} = -0.5\text{ V}$	$T_A = \text{MIN}$	2.2		2.4		V		
		$T_A = 25^\circ\text{C}$	2.4	3.4	2.4	3.4			
		$T_A = \text{MAX}$	2.4		2.4				
V_{OL}	Low-level output voltage $V_{CC} = \text{MIN}$, $I_{OL} = 15\text{ mA}$, $V_{ID} = -0.5\text{ V}$	0.22 0.4			0.22 0.45			V	
I_{IL}	Low-level input current $V_{CC} = \text{MAX}$, $V_I = 0.4\text{ V}$, Other input at 5.5 V	$T_A = \text{MIN}$	-0.9		-0.9		mA		
		$T_A = 25^\circ\text{C}$	-0.5	-0.7	-0.5	-0.7			
		$T_A = \text{MAX}$	-0.7		-0.7				
I_{SH}	High-level strobe current $V_{CC} = \text{MIN}$, $V_{ID} = -0.5\text{ V}$, $V_{\text{strobe}} = 4.5\text{ V}$	$T_A = 25^\circ\text{C}$	2		5		μA		
		$T_A = \text{MAX}$	5		10				
I_{SL}	Low-level strobe current $V_{CC} = \text{MAX}$, $V_{ID} = 0.5\text{ V}$, $V_{\text{strobe}} = 0.4\text{ V}$	$T_A = 25^\circ\text{C}$	-1.15	-2.4	-1.15	-2.4	mA		
$I_{(RTC)}$	Response-time-control current $V_{CC} = \text{MAX}$, $V_{ID} = 0.5\text{ V}$, $V_{RC} = 0$	$T_A = 25^\circ\text{C}$	-1.2	-3.4	-1.2	-3.4	mA		
$I_{O(\text{off})}$	Off-state open-collector output current $V_{CC} = \text{MIN}$, $V_{ID} = -4.5\text{ V}$, $V_{OH} = 12\text{ V}$	$T_A = 25^\circ\text{C}$	100				μA		
		$T_A = \text{MAX}$	200						
	$V_{CC} = \text{MIN}$, $V_{ID} = -4.75\text{ V}$, $V_{OH} = 5.25\text{ V}$	$T_A = 25^\circ\text{C}$			100				
		$T_A = \text{MAX}$			200				
R_T	Line-terminating resistance $V_{CC} = 5\text{ V}$	$T_A = 25^\circ\text{C}$	77	130	167	74	130	179	Ω
I_{OS}	Supply-circuit output current# $V_{CC} = \text{MAX}$, $V_{ID} = -0.5\text{ V}$, $V_O = 0$	$T_A = 25^\circ\text{C}$	-15	-40	-80	-14	-40	-100	mA
I_{CC}	Supply current (both receivers) $V_{CC} = \text{MAX}$, $V_{ID} = 0.5\text{ V}$, $V_{IC} = 0$	$T_A = 25^\circ\text{C}$	32 50		32 50		mA		

† Unless otherwise noted, $V_{\text{strobe}} = 2.4\text{ V}$. All parameters with the exception of off-state open-collector output current are measured with the active pullup connected to the sink output.

‡ All typical values are at $V_{CC} = 5\text{ V}$, $T_A = 25^\circ\text{C}$, and $V_{IC} = 0$.

§ Differential voltages are at the B input terminal with respect to the A input terminal.

¶ The algebraic convention, in which the less positive (more negative) limit is designated as minimum, is used in this data sheet for threshold voltages only.

Only one output should be shorted to ground at a time, and duration of the short circuit should not exceed one second.



SN55115, SN75115 DUAL DIFFERENTIAL RECEIVERS

SLLS072D – SEPTEMBER 1973 – REVISED MAY 1998

switching characteristics, $V_{CC} = 5\text{ V}$, $C_L = 30\text{ pF}$, $T_A = 25^\circ\text{C}$

PARAMETER	TEST CONDITIONS	SN55115			SN75115			UNIT
		MIN	TYP	MAX	MIN	TYP	MAX	
t_{PLH} Propagation delay time, low-to-high level output	$R_L = 3.9\text{ k}\Omega$, See Figure 1		18	50		18	75	ns
t_{PHL} Propagation delay time, high-to-low level output	$R_L = 390\ \Omega$, See Figure 1		20	50		20	75	ns

PARAMETER MEASUREMENT INFORMATION

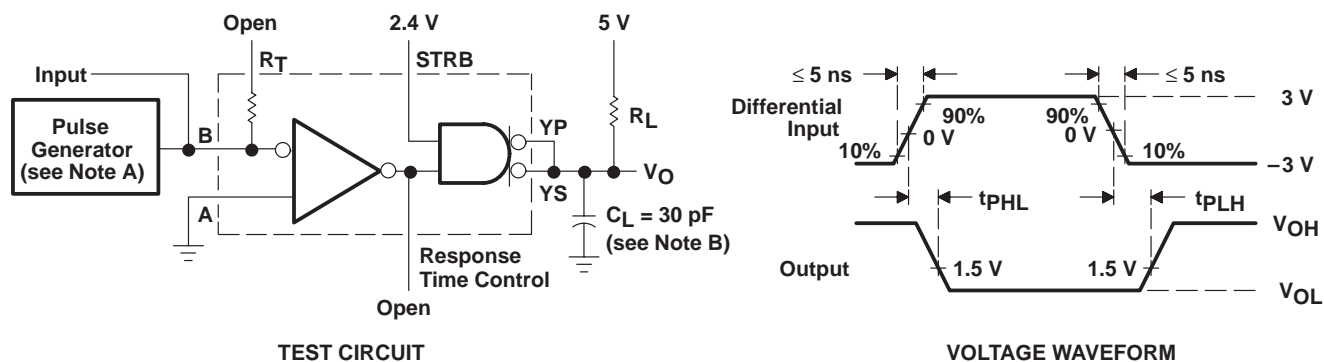

NOTES: A. The pulse generator has the following characteristics: $Z_O = 50\ \Omega$, $PRR \leq 500\text{ kHz}$, $t_w \leq 100\text{ ns}$, duty cycle = 50%.
B. C_L includes probe and jig capacitance.

Figure 1. Test Circuit and Voltage Waveforms

TYPICAL CHARACTERISTICS†

INPUT CURRENT
vs
INPUT VOLTAGE

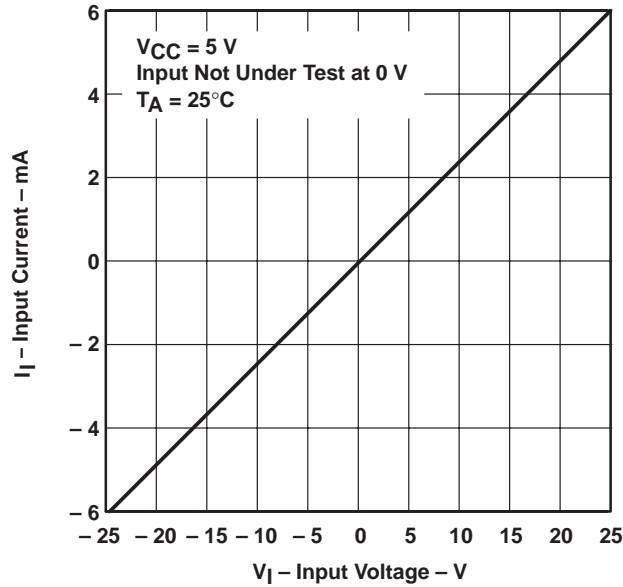

Figure 2

OUTPUT VOLTAGE
vs
FREE-AIR TEMPERATURE

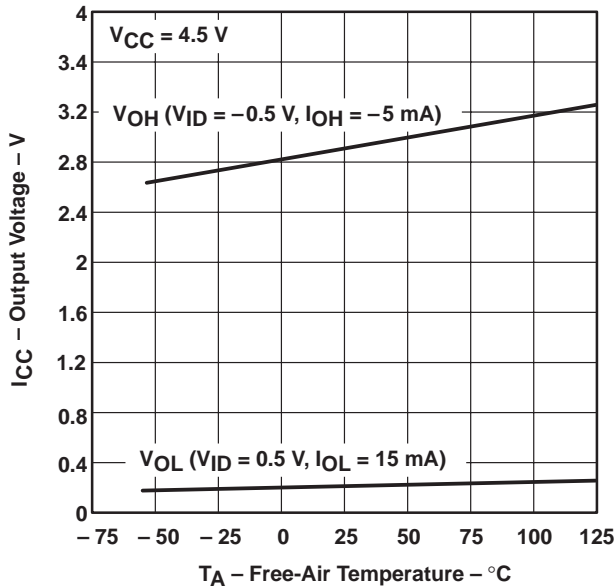

Figure 3

OUTPUT VOLTAGE
vs
COMMON-MODE INPUT VOLTAGE

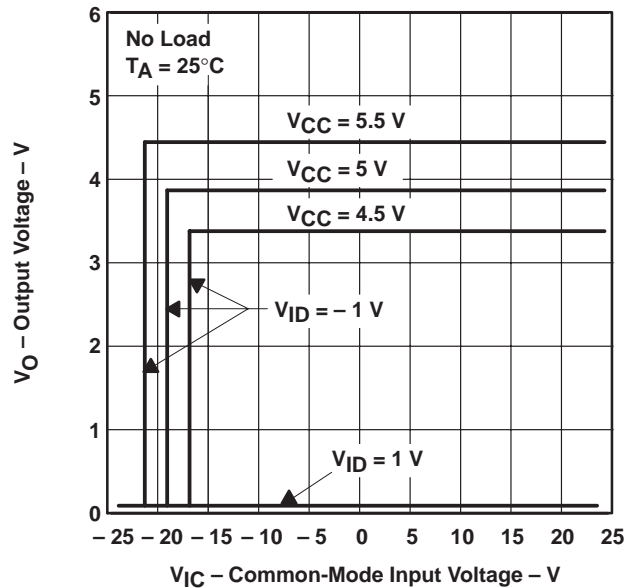

Figure 4

† Data for temperatures below 0°C and above 70°C and for supply voltages below 4.75 V and above 5.25 V are applicable to SN55115 circuits only. These parameters were measured with the active pullup connected to the sink output.

SN55115, SN75115 DUAL DIFFERENTIAL RECEIVERS

SLLS072D – SEPTEMBER 1973 – REVISED MAY 1998

TYPICAL CHARACTERISTICS

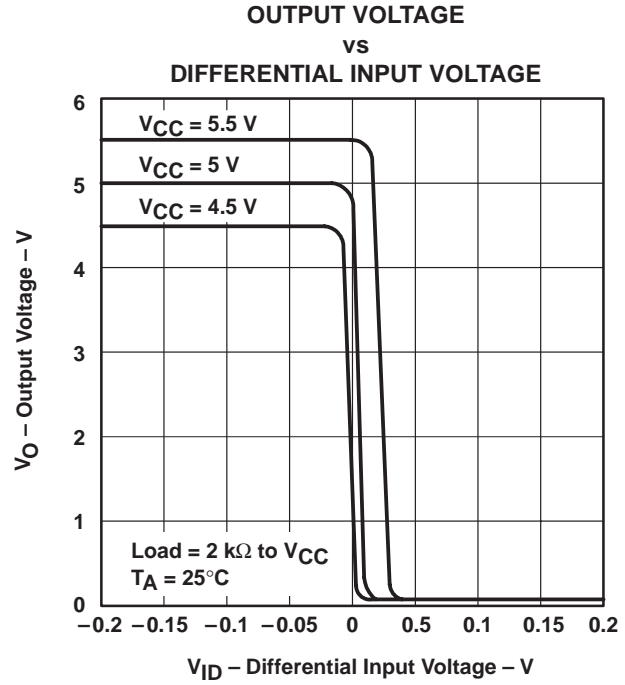
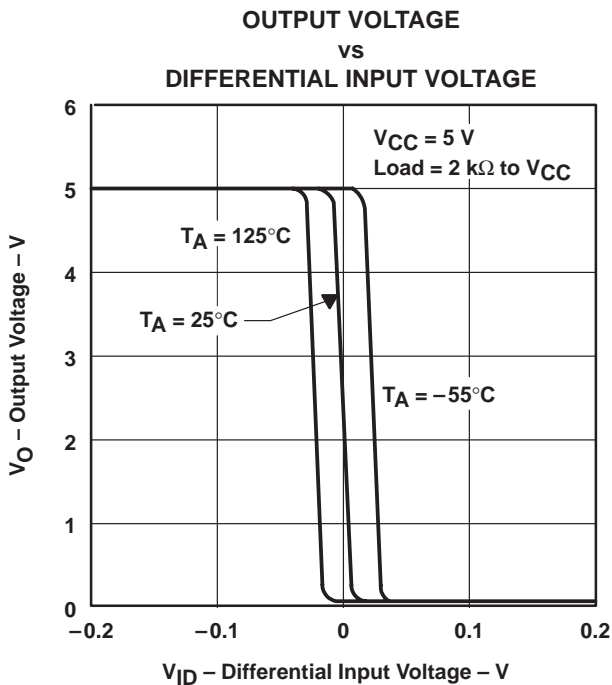
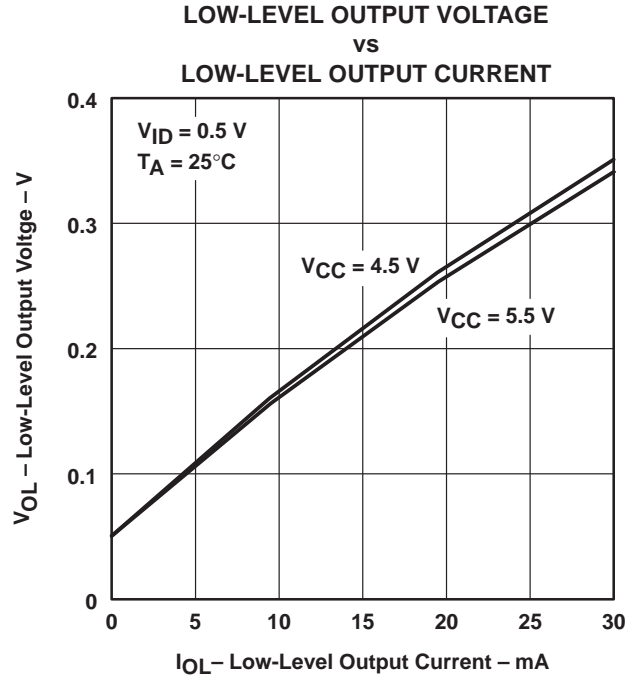
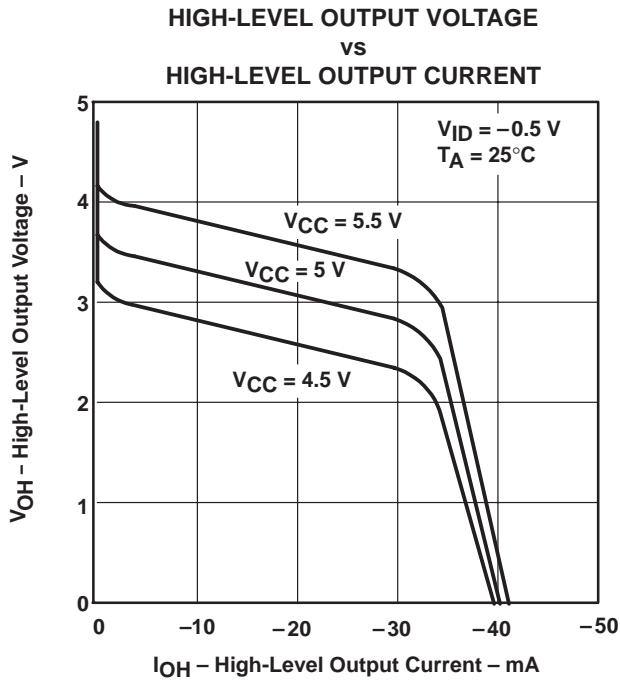

TYPICAL CHARACTERISTICS†

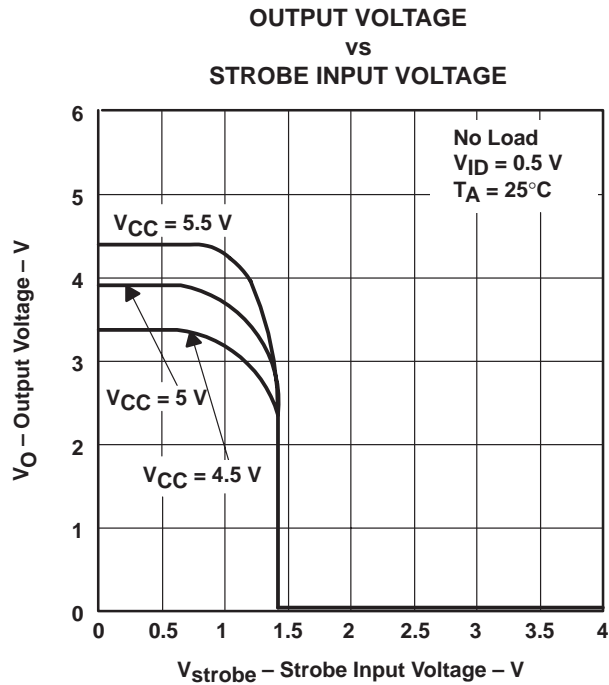

Figure 9

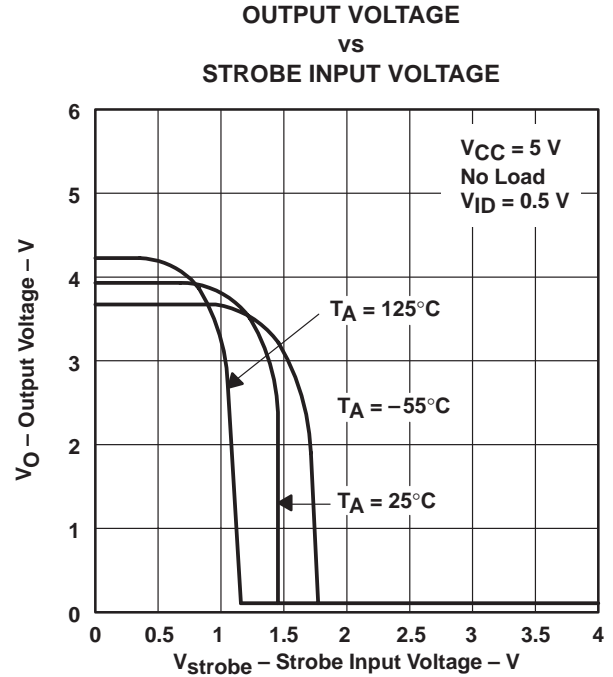

Figure 10

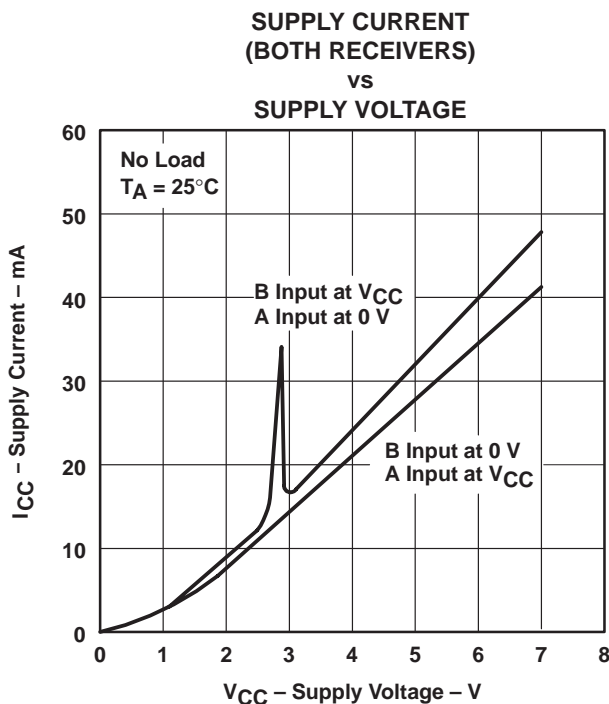

Figure 11

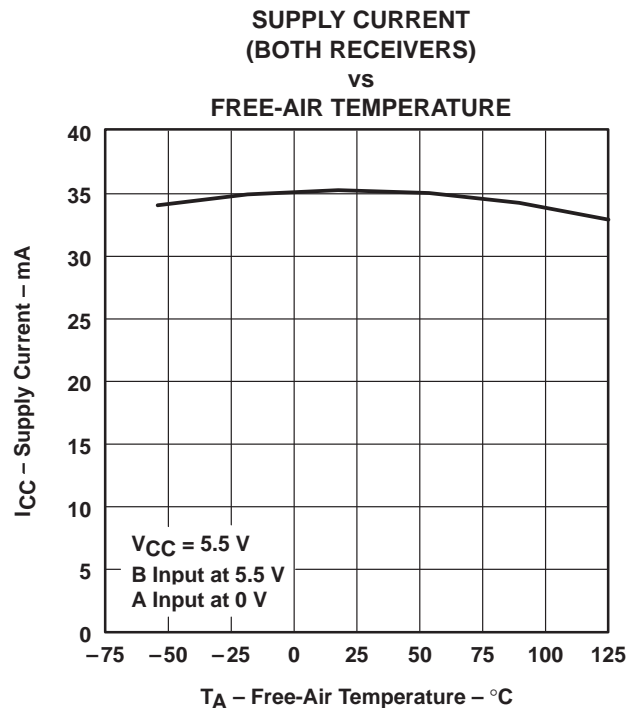

Figure 12

† Data for temperatures below 0°C and above 70°C and for supply voltages below 4.75 V and above 5.25 V are applicable to SN55115 circuits only. These parameters were measured with the active pullup connected to the sink output.

SN55115, SN75115 DUAL DIFFERENTIAL RECEIVERS

SLLS072D – SEPTEMBER 1973 – REVISED MAY 1998

TYPICAL CHARACTERISTICS†

PROPAGATION DELAY TIMES
vs
FREE-AIR TEMPERATURE

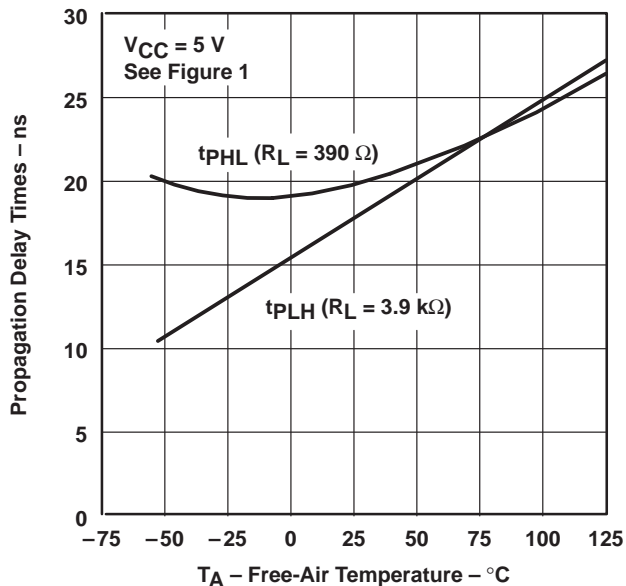

Figure 13

MAXIMUM OPERATING FREQUENCY
vs
RESPONSE-TIME-CONTROL CAPACITANCE

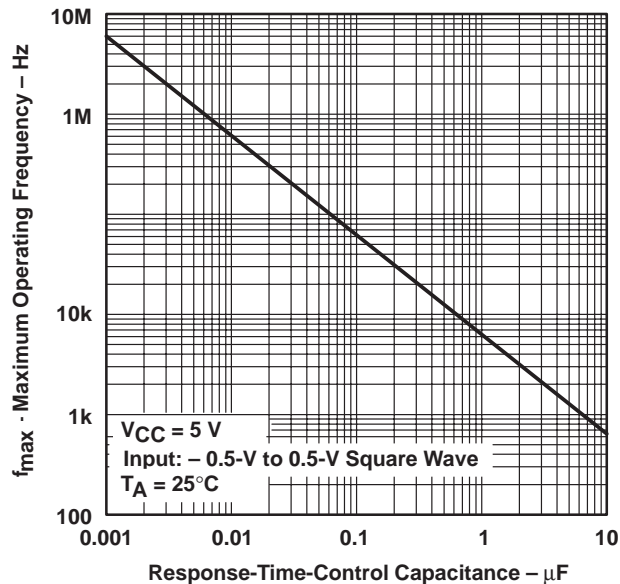
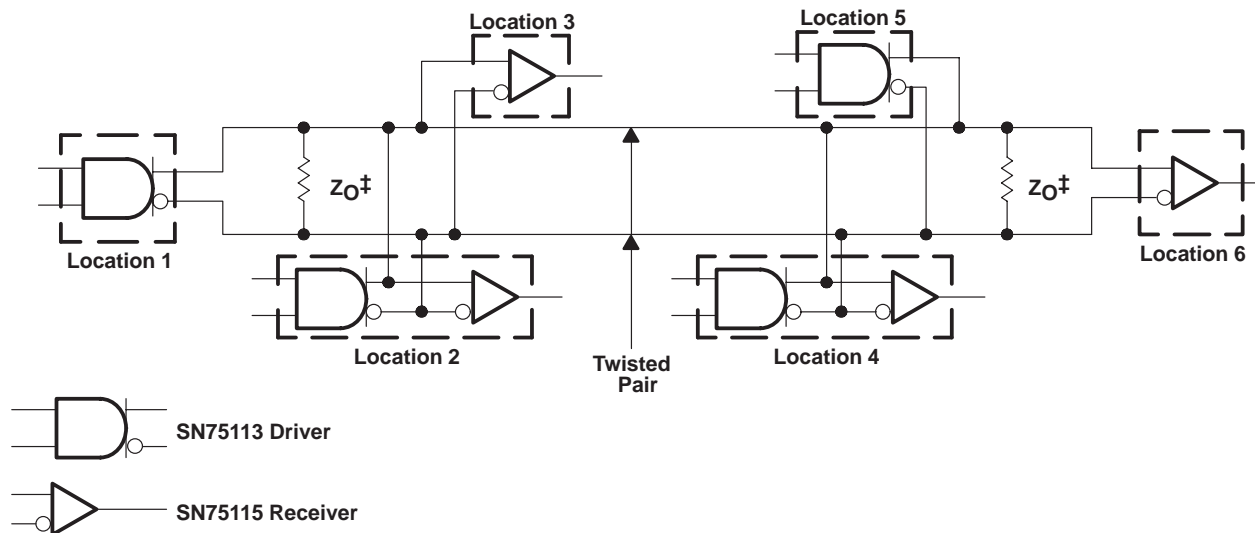

Figure 14

† Data for temperatures below 0°C and above 70°C and for supply voltages below 4.75 V and above 5.25 V are applicable to SN55115 circuits only. These parameters were measured with the active pullup connected to the sink output.

APPLICATION INFORMATION



‡ $Z_O = R_T$. A capacitor may be connected in series with Z_O to reduce power dissipation.

Figure 15. Basic Party-Line or Data-Bus Differential Data Transmission



IMPORTANT NOTICE

Texas Instruments and its subsidiaries (TI) reserve the right to make changes to their products or to discontinue any product or service without notice, and advise customers to obtain the latest version of relevant information to verify, before placing orders, that information being relied on is current and complete. All products are sold subject to the terms and conditions of sale supplied at the time of order acknowledgement, including those pertaining to warranty, patent infringement, and limitation of liability.

TI warrants performance of its semiconductor products to the specifications applicable at the time of sale in accordance with TI's standard warranty. Testing and other quality control techniques are utilized to the extent TI deems necessary to support this warranty. Specific testing of all parameters of each device is not necessarily performed, except those mandated by government requirements.

CERTAIN APPLICATIONS USING SEMICONDUCTOR PRODUCTS MAY INVOLVE POTENTIAL RISKS OF DEATH, PERSONAL INJURY, OR SEVERE PROPERTY OR ENVIRONMENTAL DAMAGE ("CRITICAL APPLICATIONS"). TI SEMICONDUCTOR PRODUCTS ARE NOT DESIGNED, AUTHORIZED, OR WARRANTED TO BE SUITABLE FOR USE IN LIFE-SUPPORT DEVICES OR SYSTEMS OR OTHER CRITICAL APPLICATIONS. INCLUSION OF TI PRODUCTS IN SUCH APPLICATIONS IS UNDERSTOOD TO BE FULLY AT THE CUSTOMER'S RISK.

In order to minimize risks associated with the customer's applications, adequate design and operating safeguards must be provided by the customer to minimize inherent or procedural hazards.

TI assumes no liability for applications assistance or customer product design. TI does not warrant or represent that any license, either express or implied, is granted under any patent right, copyright, mask work right, or other intellectual property right of TI covering or relating to any combination, machine, or process in which such semiconductor products or services might be or are used. TI's publication of information regarding any third party's products or services does not constitute TI's approval, warranty or endorsement thereof.