

SN54LVT16244B, SN74LVT16244B 3.3-V ABT 16-BIT BUFFERS/DRIVERS WITH 3-STATE OUTPUTS

SCBS716 – MARCH 2000

- Members of the Texas Instruments *Widebus™* Family
- State-of-the-Art Advanced BiCMOS Technology (ABT) Design for 3.3-V Operation and Low Static-Power Dissipation
- Support Mixed-Mode Signal Operation (5-V Input and Output Voltages With 3.3-V V_{CC})
- I_{off} and Power-Up 3-State Support Hot Insertion
- Support Unregulated Battery Operation Down to 2.7 V
- Typical V_{OLP} (Output Ground Bounce) <0.8 V at $V_{CC} = 3.3$ V, $T_A = 25^\circ\text{C}$
- Latch-Up Performance Exceeds 100 mA Per JESD 78, Class II
- ESD Protection Exceeds JESD 22
 - 2000-V Human-Body Model (A114-A)
 - 200-V Machine Model (A115-A)
 - 1000-V Charged-Device Model (C101)
- Package Options Include Plastic Shrink Small-Outline (DL), Thin Shrink Small-Outline (DGG), and Thin Very Small-Outline (DGV) Packages and 380-mil Fine-Pitch Ceramic Flat (WD) Package Using 25-mil Center-to-Center Spacings

SN54LVT16244B . . . WD PACKAGE
SN74LVT16244B . . . DGG, DGV, OR DL PACKAGE
(TOP VIEW)

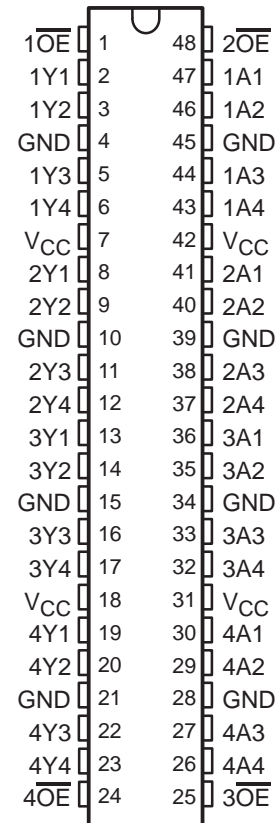

description

The 'LVT16244B devices are 16-bit buffers and line drivers designed for low-voltage (3.3-V) V_{CC} operation, but with the capability to provide a TTL interface to a 5-V system environment. These devices can be used as four 4-bit buffers, two 8-bit buffers, or one 16-bit buffer. These devices provide true outputs and symmetrical active-low output-enable (\overline{OE}) inputs.

When V_{CC} is between 0 and 1.5-V, the devices are in the high-impedance state during power up or power down. However, to ensure the high-impedance state above 1.5-V, \overline{OE} should be tied to V_{CC} through a pullup resistor; the minimum value of the resistor is determined by the current-sinking capability of the driver.

These devices are fully specified for hot-insertion applications using I_{off} and power-up 3-state. The I_{off} circuitry disables the outputs, preventing damaging current backflow through the devices when they are powered down. The power-up 3-state circuitry places the outputs in the high-impedance state during power up and power down, which prevents driver conflict.

The SN54LVT16244B is characterized for operation over the full military temperature range of -55°C to 125°C . The SN74LVT16244B is characterized for operation from -40°C to 85°C .



Please be aware that an important notice concerning availability, standard warranty, and use in critical applications of Texas Instruments semiconductor products and disclaimers thereto appears at the end of this data sheet.

Widebus is a trademark of Texas Instruments.

UNLESS OTHERWISE NOTED this document contains PRODUCTION DATA information current as of publication date. Products conform to specifications per the terms of Texas Instruments standard warranty. Production processing does not necessarily include testing of all parameters.

 **TEXAS
INSTRUMENTS**

POST OFFICE BOX 655303 • DALLAS, TEXAS 75265

Copyright © 2000, Texas Instruments Incorporated

SN54LVT16244B, SN74LVT16244B
3.3-V ABT 16-BIT BUFFERS/DRIVERS
WITH 3-STATE OUTPUTS

SCBS716 – MARCH 2000

FUNCTION TABLE
 (each 4-bit buffer)

INPUTS		OUTPUT
\overline{OE}	A	Y
L	H	H
L	L	L
H	X	Z

logic symbol†

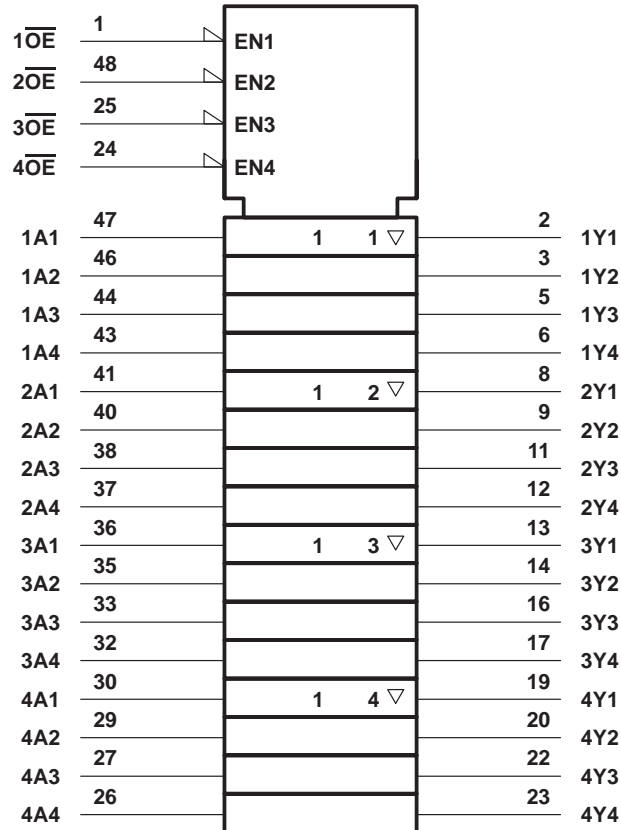

† This symbol is in accordance with ANSI/IEEE Std 91-1984 and IEC Publication 617-12.

logic diagram (positive logic)

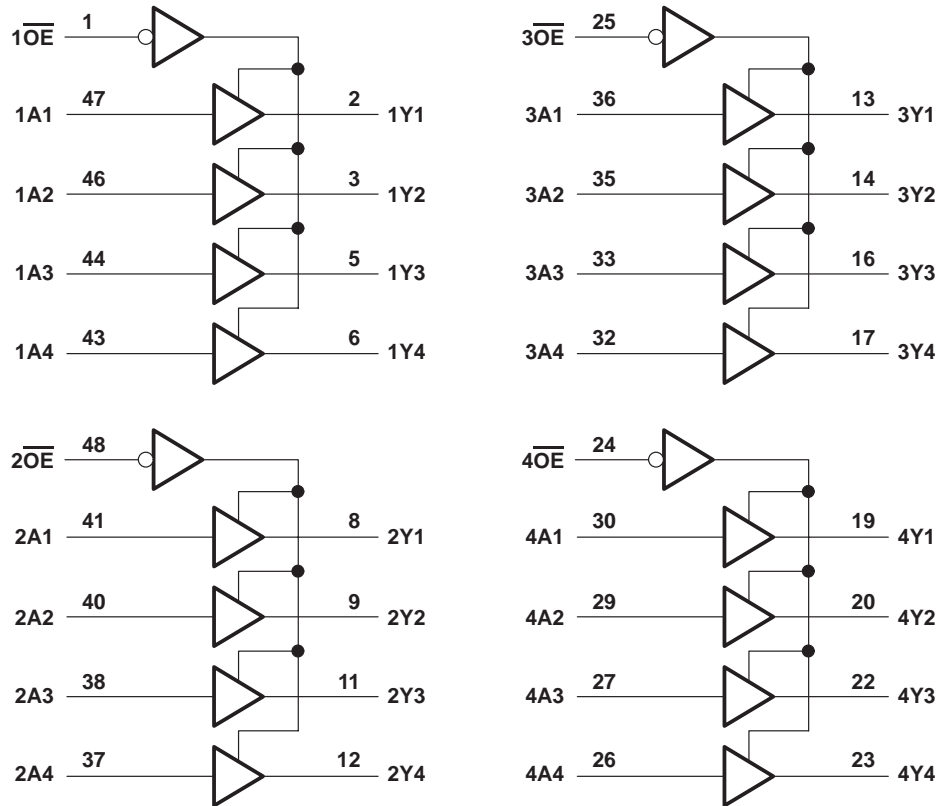

absolute maximum ratings over operating free-air temperature range (unless otherwise noted)†

Supply voltage range, V_{CC}	-0.5 V to 4.6 V
Input voltage range, V_I (see Note 1)	-0.5 V to 7 V
Voltage range applied to any output in the high-impedance or power-off state, V_O (see Note 1)	-0.5 V to 7 V
Voltage range applied to any output in the high state, V_O (see Note 1)	-0.5 V to $V_{CC} + 0.5$ V
Current into any output in the low state, I_O : SN54LVT16244B	96 mA
SN74LVT16244B	128 mA
Current into any output in the high state, I_O (see Note 2): SN54LVT16244B	48 mA
SN74LVT16244B	64 mA
Input clamp current, I_{IK} ($V_I < 0$)	-50 mA
Output clamp current, I_{OK} ($V_O < 0$)	-50 mA
Package thermal impedance, θ_{JA} (see Note 3): DGG package	70°C/W
DGV package	58°C/W
DL package	63°C/W
Storage temperature range, T_{stg}	-65°C to 150°C

† Stresses beyond those listed under “absolute maximum ratings” may cause permanent damage to the device. These are stress ratings only, and functional operation of the device at these or any other conditions beyond those indicated under “recommended operating conditions” is not implied. Exposure to absolute-maximum-rated conditions for extended periods may affect device reliability.

- NOTES: 1. The input and output negative-voltage ratings may be exceeded if the input and output clamp-current ratings are observed.
2. This current flows only when the output is in the high state and $V_O > V_{CC}$.
3. The package thermal impedance is calculated in accordance with JESD 51.

SN54LVT16244B, SN74LVT16244B
3.3-V ABT 16-BIT BUFFERS/DRIVERS
WITH 3-STATE OUTPUTS

SCBS716 – MARCH 2000

recommended operating conditions (see Note 4)

		SN54LVT16244B		SN74LVT16244B		UNIT
		MIN	MAX	MIN	MAX	
V _{CC}	Supply voltage	2.7	3.6	2.7	3.6	V
V _{IH}	High-level input voltage	2		2		V
V _{IL}	Low-level input voltage		0.8		0.8	V
V _I	Input voltage		5.5		5.5	V
I _{OH}	High-level output current		-24		-32	mA
I _{OL}	Low-level output current		48		64	mA
Δt/Δv	Input transition rise or fall rate	Outputs enabled		10	10	ns/V
Δt/ΔV _{CC}	Power-up ramp rate	200		200		μs/V
T _A	Operating free-air temperature	-55	125	-40	85	°C

NOTE 4: All unused inputs of the device must at V_{CC} or GND to ensure proper device operation. Refer to the TI application report, *Implications of Slow or Floating CMOS Inputs*, literature number SCBA004.

SN54LVT16244B, SN74LVT16244B
3.3-V ABT 16-BIT BUFFERS/DRIVERS
WITH 3-STATE OUTPUTS

SCBS716 – MARCH 2000

electrical characteristics over recommended operating free-air temperature range (unless otherwise noted)

PARAMETER	TEST CONDITIONS		SN54LVT16244B		SN74LVT16244B		UNIT	
			MIN	TYP†	MAX	MIN		TYP†
V_{IK}	$V_{CC} = 2.7\text{ V}$,	$I_I = -18\text{ mA}$			-1.2		-1.2	V
V_{OH}	$V_{CC} = 2.7\text{ V to }3.6\text{ V}$,	$I_{OH} = -100\text{ }\mu\text{A}$	$V_{CC}-0.2$		$V_{CC}-0.2$		V	
	$V_{CC} = 2.7\text{ V}$,	$I_{OH} = -8\text{ mA}$	2.4		2.4			
	$V_{CC} = 3\text{ V}$	$I_{OH} = -24\text{ mA}$ $I_{OH} = -32\text{ mA}$	2		2			
V_{OL}	$V_{CC} = 2.7\text{ V}$	$I_{OL} = 100\text{ }\mu\text{A}$	0.2		0.2		V	
		$I_{OL} = 24\text{ mA}$	0.5		0.5			
	$V_{CC} = 3\text{ V}$	$I_{OL} = 16\text{ mA}$	0.4		0.4			
		$I_{OL} = 32\text{ mA}$	0.5		0.5			
		$I_{OL} = 48\text{ mA}$	0.55		0.55			
		$I_{OL} = 64\text{ mA}$			0.55			
I_I		$V_{CC} = 0\text{ or }3.6\text{ V}$,	$V_I = 5.5\text{ V}$	50		10	μA	
	Control inputs	$V_{CC} = 3.6\text{ V}$,	$V_I = V_{CC}\text{ or GND}$	± 1		± 1		
	Data inputs	$V_{CC} = 3.6\text{ V}$	$V_I = V_{CC}$	1		1		
$V_I = 0$			-5		-5			
I_{off}	$V_{CC} = 0$, V_I or $V_O = 0\text{ to }4.5\text{ V}$					± 100	μA	
I_{OZH}	$V_{CC} = 3.6\text{ V}$,	$V_O = 3\text{ V}$		5		5	μA	
I_{OZL}	$V_{CC} = 3.6\text{ V}$,	$V_O = 0.5\text{ V}$		-5		-5	μA	
I_{OZPU}	$V_{CC} = 0\text{ to }1.5\text{ V}$, $V_O = 0.5\text{ V to }3\text{ V}$, $\overline{OE} = \text{don't care}$			$\pm 100^*$		± 100	μA	
I_{OZPD}	$V_{CC} = 1.5\text{ V to }0$, $V_O = 0.5\text{ V to }3\text{ V}$, $\overline{OE} = \text{don't care}$			$\pm 100^*$		± 100	μA	
I_{CC}	$V_{CC} = 3.6\text{ V}$, $I_O = 0$, $V_I = V_{CC}\text{ or GND}$	Outputs high		0.19		0.19	mA	
		Outputs low		5		5		
		Outputs disabled		0.19		0.19		
ΔI_{CC}^\ddagger	$V_{CC} = 3\text{ V to }3.6\text{ V}$, One input at $V_{CC} - 0.6\text{ V}$, Other inputs at V_{CC} or GND			0.2		0.2	mA	
C_i	$V_I = 3\text{ V or }0$			4		4	pF	
C_o	$V_O = 3\text{ V or }0$			9		9	pF	

*On products compliant to MIL-PRF-38535, this parameter is not production tested.

† All typical values are at $V_{CC} = 3.3\text{ V}$, $T_A = 25^\circ\text{C}$.

‡ This is the increase in supply current for each input that is at the specified TTL voltage level rather than V_{CC} or GND.

PRODUCT PREVIEW information concerns products in the formative or design phase of development. Characteristic data and other specifications are design goals. Texas Instruments reserves the right to change or discontinue these products without notice.



POST OFFICE BOX 655303 • DALLAS, TEXAS 75265

SN54LVT16244B, SN74LVT16244B
3.3-V ABT 16-BIT BUFFERS/DRIVERS
WITH 3-STATE OUTPUTS

SCBS716 – MARCH 2000

switching characteristics over recommended operating free-air temperature range, $C_L = 50$ pF (unless otherwise noted) (see Figure 1)

PARAMETER	FROM (INPUT)	TO (OUTPUT)	SN54LVT16244B				SN74LVT16244B				UNIT	
			$V_{CC} = 3.3\text{ V} \pm 0.3\text{ V}$		$V_{CC} = 2.7\text{ V}$		$V_{CC} = 3.3\text{ V} \pm 0.3\text{ V}$			$V_{CC} = 2.7\text{ V}$		
			MIN	MAX	MIN	MAX	MIN	TYP†	MAX	MIN		MAX
t_{PLH}	A	Y	1.1	4.4		4.6	1.2	2.3	3.2		3.7	ns
t_{PHL}			1.1	3.6		3.9	1.2	2	3.2		3.7	
t_{PZH}	\overline{OE}	Y	1.1	4.6		5.4	1.2	2.6	4		5	ns
t_{PZL}			1.1	5.4		6.2	1.2	2.7	4		5	
t_{PHZ}	\overline{OE}	Y	1.6	5.7		6.2	2.2	3.3	4.5		5	ns
t_{PLZ}			1.2	5		4.7	2	3.1	4.2		4.4	
$t_{sk(o)}$								0.5			ns	

† All typical values are at $V_{CC} = 3.3\text{ V}$, $T_A = 25^\circ\text{C}$.

PARAMETER MEASUREMENT INFORMATION

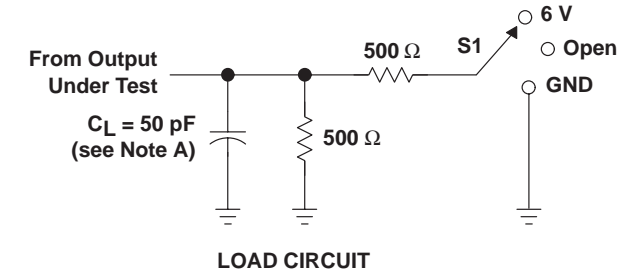

TEST	S1
t_{PLH}/t_{PHL}	Open
t_{PLZ}/t_{PZL}	6 V
t_{PHZ}/t_{PZH}	GND

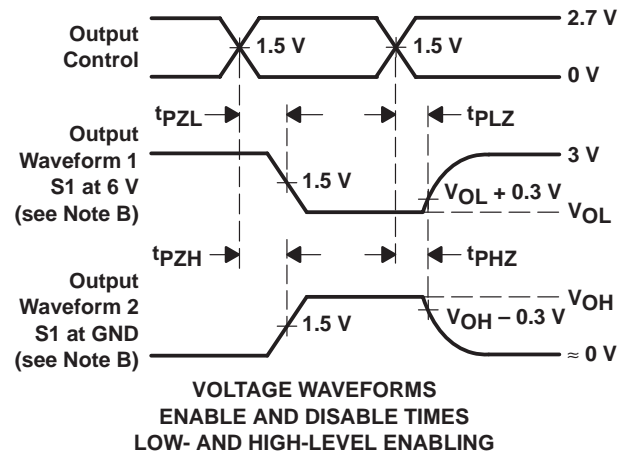
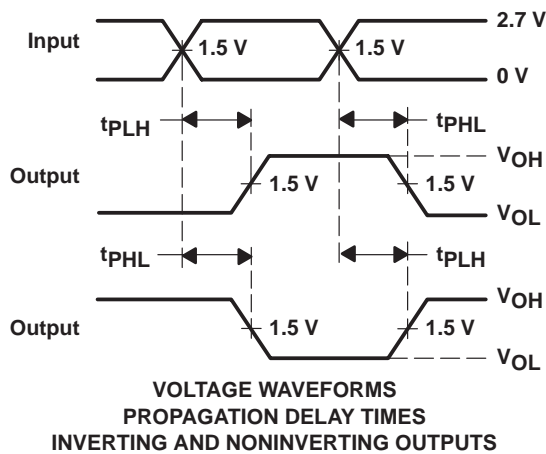
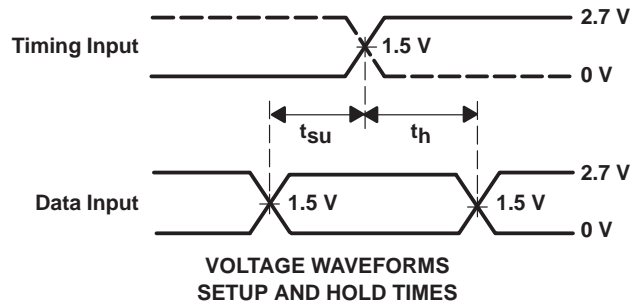
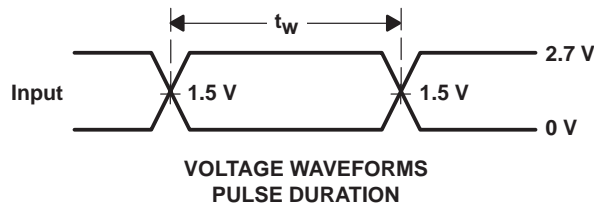

- NOTES: A. C_L includes probe and jig capacitance.
B. Waveform 1 is for an output with internal conditions such that the output is low except when disabled by the output control. Waveform 2 is for an output with internal conditions such that the output is high except when disabled by the output control.
C. All input pulses are supplied by generators having the following characteristics: $PRR \leq 10 \text{ MHz}$, $Z_O = 50 \Omega$, $t_r \leq 2.5 \text{ ns}$, $t_f \leq 2.5 \text{ ns}$.
D. The outputs are measured one at a time with one transition per measurement.

Figure 1. Load Circuit and Voltage Waveforms

IMPORTANT NOTICE

Texas Instruments and its subsidiaries (TI) reserve the right to make changes to their products or to discontinue any product or service without notice, and advise customers to obtain the latest version of relevant information to verify, before placing orders, that information being relied on is current and complete. All products are sold subject to the terms and conditions of sale supplied at the time of order acknowledgment, including those pertaining to warranty, patent infringement, and limitation of liability.

TI warrants performance of its semiconductor products to the specifications applicable at the time of sale in accordance with TI's standard warranty. Testing and other quality control techniques are utilized to the extent TI deems necessary to support this warranty. Specific testing of all parameters of each device is not necessarily performed, except those mandated by government requirements.

Customers are responsible for their applications using TI components.

In order to minimize risks associated with the customer's applications, adequate design and operating safeguards must be provided by the customer to minimize inherent or procedural hazards.

TI assumes no liability for applications assistance or customer product design. TI does not warrant or represent that any license, either express or implied, is granted under any patent right, copyright, mask work right, or other intellectual property right of TI covering or relating to any combination, machine, or process in which such semiconductor products or services might be or are used. TI's publication of information regarding any third party's products or services does not constitute TI's approval, warranty or endorsement thereof.