

SN54LS540, SN54LS541, SN74LS540, SN74LS541 OCTAL BUFFERS AND LINE DRIVERS WITH 3-STATE OUTPUTS

SDLS180—AUGUST 1979—REVISED MARCH 1988

- 3-State Outputs Drive Bus Lines or Buffer Memory Address Registers
- P-N-P Inputs Reduce D-C Loading
- Hysteresis at Inputs Improves Noise Margins
- Data Flow-thru Pinout (All Inputs on Opposite Side from Outputs)

description

These octal buffers and line drivers are designed to have the performance of the popular SN54LS240/SN74LS240 series and, at the same time, offer a pinout having the inputs and outputs on opposite sides of the package. This arrangement greatly enhances printed circuit board layout.

The three-state control gate is a 2-input NOR such that if either $\overline{G1}$ or $\overline{G2}$ are high, all eight outputs are in the high-impedance state.

The 'LS540 offers inverting data and the 'LS541 offers true data at the outputs.

The SN54LS540 and SN54LS541 are characterized for operation over the full military temperature range of -55°C to 125°C . The SN74LS540 and SN74LS541 are characterized for operation from 0°C to 70°C .

TYPE	RATED	RATED	TYPICAL POWER	
	I_{OL} (SINK CURRENT)	I_{OH} (SOURCE CURRENT)	'LS540	'LS541
SN54LS'	12 mA	-12 mA	92.5 mW	120 mW
SN74LS'	24 mA	-15 mA	92.5 mW	120 mW

schematics of inputs and outputs

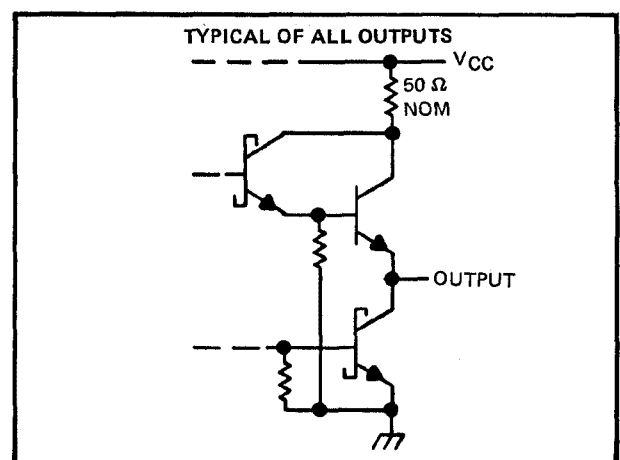
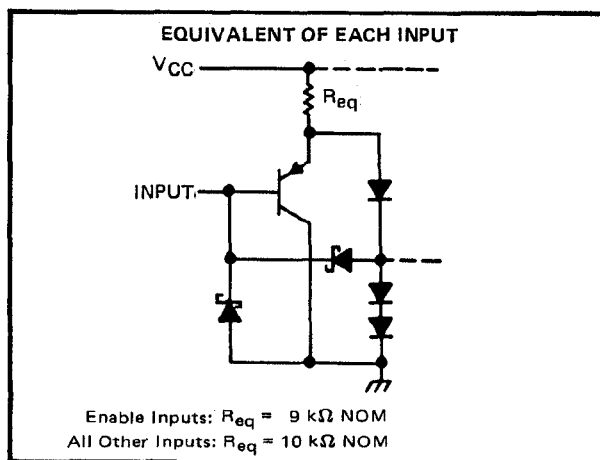

SN54LS540, SN54LS541 . . . J OR W PACKAGE
SN74LS540, SN74LS541 . . . DW OR N PACKAGE
(TOP VIEW)

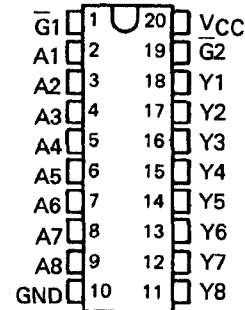

SN54LS540, SN54LS541 . . . FK PACKAGE
(TOP VIEW)

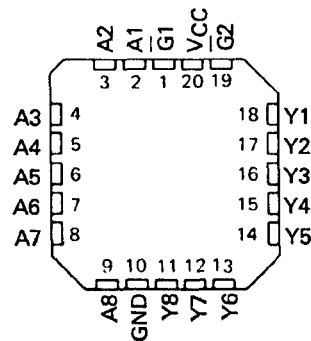

PRODUCTION DATA information is current as of publication date. Products conform to specifications per the terms of Texas Instruments standard warranty. Production processing does not necessarily include testing of all parameters.

 **TEXAS
INSTRUMENTS**

POST OFFICE BOX 655303 • DALLAS, TEXAS 75265

Copyright © 1988, Texas Instruments Incorporated

SN54LS540, SN54LS541, SN74LS540, SN74LS541

OCTAL BUFFERS AND LINE DRIVERS

WITH 3-STATE OUTPUTS

SDLS180 – AUGUST 1979 – REVISED MARCH 1988

logic symbols†

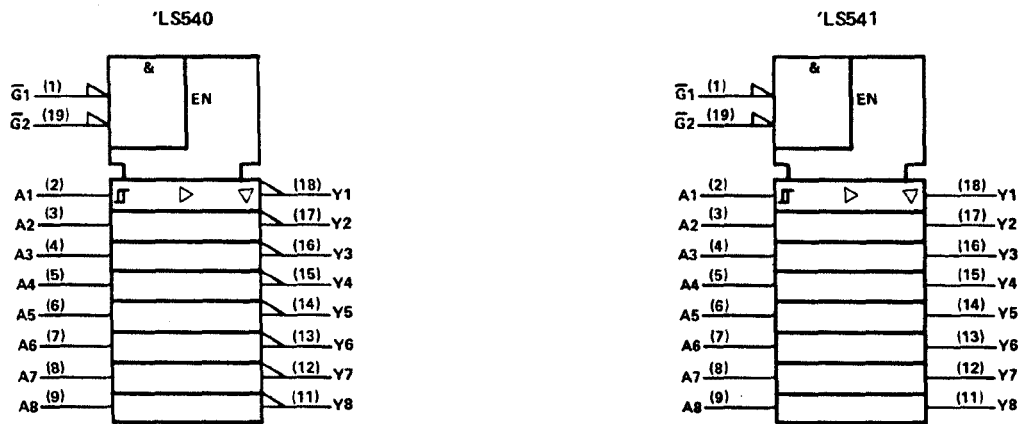

† These symbols are in accordance with ANSI/IEEE Std 91-1984 and IEC Publication 617-12.

logic diagram (positive logic)

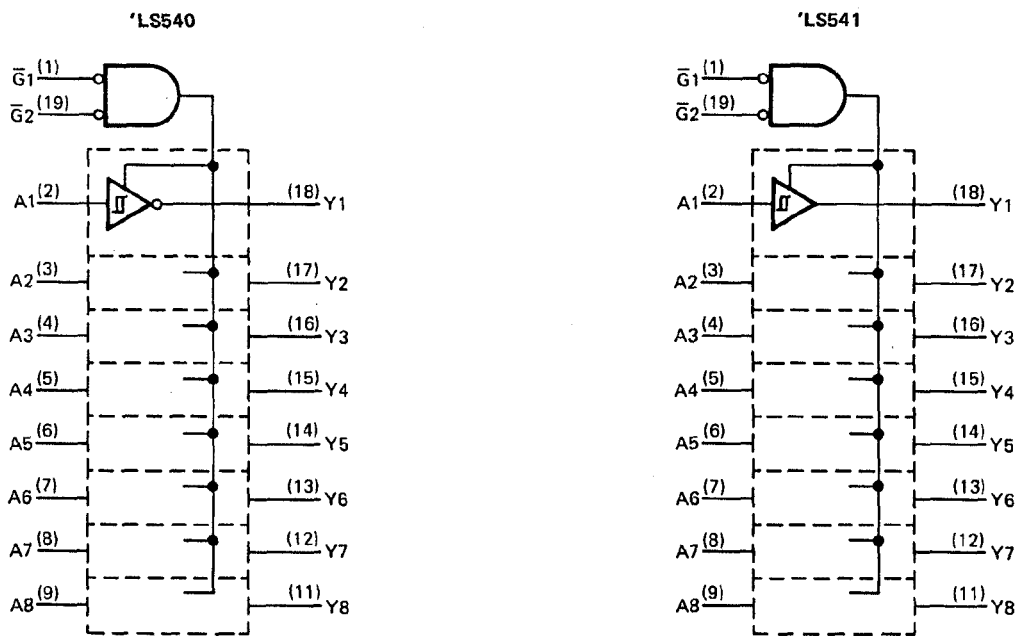

absolute maximum ratings over operating free-air temperature range (unless otherwise noted)

Supply voltage, V_{CC} (see Note 1)	7 V
Input voltage	7 V
Operating free-air temperature range: SN54LS540, SN54LS541	-55°C to 125°C
SN74LS540, SN74LS541	0°C to 70°C
Storage temperature range	-65°C to 150°C

NOTE 1: Voltage values are with respect to the network ground terminal.



POST OFFICE BOX 655303 • DALLAS, TEXAS 75265

SN54LS540, SN54LS541, SN74LS540, SN74LS541 OCTAL BUFFERS AND LINE DRIVERS WITH 3-STATE OUTPUTS

SDLS180 – AUGUST 1979 – REVISED MARCH 1988

recommended operating conditions

PARAMETER	SN54LS'			SN74LS'			UNIT
	MIN	NOM	MAX	MIN	NOM	MAX	
Supply voltage, V_{CC} (see Note 1)	4.5	5	5.5	4.75	5	5.25	V
High-level output current, I_{OH}			-12			-15	mA
Low-level output current, I_{OL}			12			24	mA
Operating free-air temperature, T_A	-55		125	0		70	°C

NOTE 1: Voltage values are with respect to network ground terminal.

electrical characteristics over recommended operating free-air temperature range (unless otherwise noted)

PARAMETER	TEST CONDITIONS [†]	SN54LS'			SN74LS'			UNIT
		MIN	TYP [‡]	MAX	MIN	TYP [‡]	MAX	
V_{IH} High-level input voltage		2			2			V
V_{IL} Low-level input voltage				0.6			0.6	V
V_{IK} Input clamp voltage	$V_{CC} = \text{MIN}, I_I = -18 \text{ mA}$			-1.5			-1.5	V
Hysteresis ($V_{T+} - V_{T-}$)	$V_{CC} = \text{MIN}$	0.2	0.4		0.2	0.4		V
V_{OH} High-level output voltage	$V_{CC} = \text{MIN}, V_{IH} = 2 \text{ V}, V_{IL} = V_{IL \text{ max}}, I_{OH} = -3 \text{ mA}$	2.4	3.4		2.4	3.4		V
	$V_{CC} = \text{MIN}, V_{IH} = 2 \text{ V}, V_{IL} = 0.5 \text{ V}, I_{OH} = \text{MAX}$	2			2			
V_{OL} Low-level output voltage	$V_{CC} = \text{MIN}, I_{OL} = 12 \text{ mA}$		0.25	0.4		0.25	0.4	V
	$V_{CC} = \text{MIN}, V_{IH} = 2 \text{ V}, V_{IL} = V_{IL \text{ max}}, I_{OL} = 24 \text{ mA}$					0.35	0.5	
I_{OZH} Off-state output current, high-level voltage applied	$V_{CC} = \text{MAX}, V_{IH} = 2 \text{ V}, V_O = 2.7 \text{ V}$			20			20	μA
I_{OZL} Off-state output current, low-level voltage applied	$V_{CC} = \text{MAX}, V_{IL} = V_{IL \text{ max}}, V_O = 0.4 \text{ V}$			-20			-20	
I_I Input current at maximum input voltage	$V_{CC} = \text{MAX}, V_I = 7 \text{ V}$			0.1			0.1	mA
I_{IH} High-level input current, any input	$V_{CC} = \text{MAX}, V_I = 2.7 \text{ V}$			20			20	μA
I_{IL} Low-level input current	$V_{CC} = \text{MAX}, V_I = 0.4 \text{ V}$			-0.2			-0.2	mA
I_{OS} Short-circuit output current [§]	$V_{CC} = \text{MAX}$	-40		-225	-40		-225	mA
I_{CC} Supply current	Outputs high	$V_{CC} = \text{MAX},$ Outputs open	'LS540	13	25	13	25	mA
			'LS541	18	32	18	32	
	Outputs low		'LS540	24	45	24	45	
			'LS541	30	52	30	52	
	All outputs disabled		'LS540	30	52	30	52	
			'LS541	32	55	32	55	

[†]For conditions shown as MIN or MAX, use the appropriate value specified under recommended operating conditions.

[‡]All typical values are at $V_{CC} = 5 \text{ V}, T_A = 25^\circ\text{C}$.

[§]Not more than one output should be shorted at a time, and duration of the short-circuit should not exceed one second.



SN54LS540, SN54LS541, SN74LS540, SN74LS541
OCTAL BUFFERS AND LINE DRIVERS
WITH 3-STATE OUTPUTS

SDLS180 – AUGUST 1979 – REVISED MARCH 1988

switching characteristics, $V_{CC} = 5\text{ V}$, $T_A = 25^\circ\text{C}$

PARAMETER	TEST CONDITIONS	'LS540			'LS541			UNIT
		MIN	TYP	MAX	MIN	TYP	MAX	
t _{PLH} Propagation delay time, low-to-high-level output	$C_L = 45\text{ pF}$, $R_L = 667\ \Omega$, See Note 2	9	15		9	15	ns	
t _{PHL} Propagation delay time, high-to-low-level output		9	15		10	18	ns	
t _{PZL} Output enable time to low level		25	38		25	38	ns	
t _{PZH} Output enable time to high level		15	25		20	32	ns	
t _{PLZ} Output disable time from low level	$C_L = 5\text{ pF}$, $R_L = 667\ \Omega$, See Note 2	10	18		10	18	ns	
t _{PHZ} Output disable time from high level		15	25		18	29	ns	

NOTE 2: Load circuits and voltage waveforms are shown in Section 1.



IMPORTANT NOTICE

Texas Instruments and its subsidiaries (TI) reserve the right to make changes to their products or to discontinue any product or service without notice, and advise customers to obtain the latest version of relevant information to verify, before placing orders, that information being relied on is current and complete. All products are sold subject to the terms and conditions of sale supplied at the time of order acknowledgement, including those pertaining to warranty, patent infringement, and limitation of liability.

TI warrants performance of its semiconductor products to the specifications applicable at the time of sale in accordance with TI's standard warranty. Testing and other quality control techniques are utilized to the extent TI deems necessary to support this warranty. Specific testing of all parameters of each device is not necessarily performed, except those mandated by government requirements.

CERTAIN APPLICATIONS USING SEMICONDUCTOR PRODUCTS MAY INVOLVE POTENTIAL RISKS OF DEATH, PERSONAL INJURY, OR SEVERE PROPERTY OR ENVIRONMENTAL DAMAGE ("CRITICAL APPLICATIONS"). TI SEMICONDUCTOR PRODUCTS ARE NOT DESIGNED, AUTHORIZED, OR WARRANTED TO BE SUITABLE FOR USE IN LIFE-SUPPORT DEVICES OR SYSTEMS OR OTHER CRITICAL APPLICATIONS. INCLUSION OF TI PRODUCTS IN SUCH APPLICATIONS IS UNDERSTOOD TO BE FULLY AT THE CUSTOMER'S RISK.

In order to minimize risks associated with the customer's applications, adequate design and operating safeguards must be provided by the customer to minimize inherent or procedural hazards.

TI assumes no liability for applications assistance or customer product design. TI does not warrant or represent that any license, either express or implied, is granted under any patent right, copyright, mask work right, or other intellectual property right of TI covering or relating to any combination, machine, or process in which such semiconductor products or services might be or are used. TI's publication of information regarding any third party's products or services does not constitute TI's approval, warranty or endorsement thereof.