

SN54LS446, SN54LS449, SN74LS446, SN74LS449 QUADRUPLE BUS TRANSCEIVERS WITH INDIVIDUAL DIRECTION CONTROLS

SDLS178

D2613, OCTOBER 1980—REVISED MARCH 1988

SN54LS446, SN54LS449 . . . J PACKAGE
SN74LS446, SN74LS449 . . . D OR N PACKAGE

(TOP VIEW)

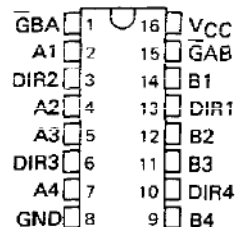

- 3-State Outputs Drive Bus Lines Directly
- P-N-P Inputs Reduce DC Loading on Bus Line
- Hysteresis at Bus Inputs Improves Noise Margins
- Flow-Thru Data Pinout (B Bus Opposite A Bus)
- Choice of True ('LS449) and Inverting ('LS446)

description

These quadruple bus transceivers are designed for data transmission from individual lines of the A bus to individual lines of the B bus or the reverse, depending on the logic levels at the direction-control pins DIR1 through DIR4. These direction controls (one for each channel) allow maximum flexibility in timing. The enable inputs $\overline{\text{GBA}}$ and $\overline{\text{GAB}}$ can be used to disable the A or B outputs respectively, or to disable both buses for effective isolation.

The SN54LS446 and SN54LS449 are characterized for operation over the full military temperature range of -55°C to 125°C . The SN74LS446 and SN74LS449 are characterized for operation from 0°C to 70°C .

SN54LS446, SN54LS449 . . . FK PACKAGE

(TOP VIEW)

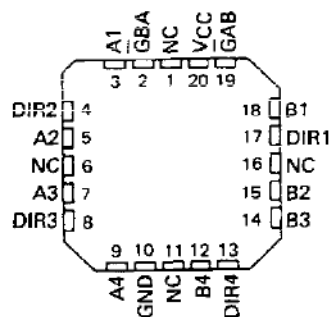

NC - No internal connection

FUNCTION TABLE

ENABLE		DIRECTION DIR	OPERATION	
$\overline{\text{GBA}}$	$\overline{\text{GAB}}$		'LS446	'LS449
H	H	X	Isolation	Isolation
X	L	H	$\overline{\text{A}}$ data to B Bus	A data to B Bus
L	X	L	$\overline{\text{B}}$ data to A Bus	B data to A Bus
X	H	H	Isolation	Isolation
H	X	L	Isolation	Isolation

H = high level, L = low level, X = irrelevant

absolute maximum ratings over operating free-air temperature range (unless otherwise noted)

Supply voltage, V_{CC} (see Note 1)	7 V
Input voltage	7 V
Off-state output voltage	5.5 V
Operating free-air temperature range: SN54LS'	-55°C to 125°C
SN74LS'	0°C to 70°C
Storage temperature range	-65°C to 150°C

NOTE 1: Voltage values are with respect to the network ground terminal.

PRODUCTION DATA documents contain information current as of publication date. Products conform to specifications per the terms of Texas Instruments standard warranty. Production processing does not necessarily include testing of all parameters.

TEXAS
INSTRUMENTS

POST OFFICE BOX 655012 • DALLAS, TEXAS 75266

SN54LS446, SN54LS449, SN74LS446, SN74LS449 QUADRUPLE BUS TRANSCEIVERS WITH INDIVIDUAL DIRECTION CONTROLS

logic symbols†

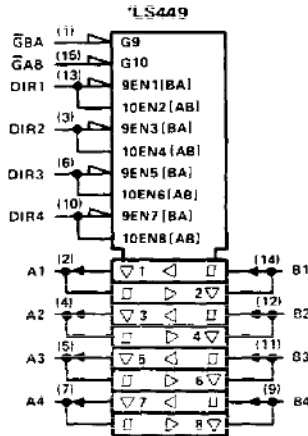
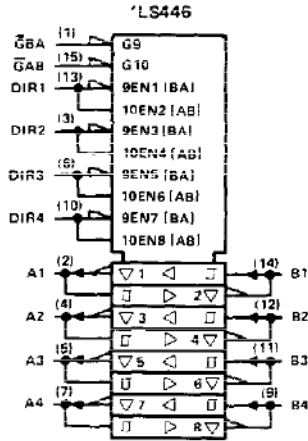

logic diagrams (positive logic)

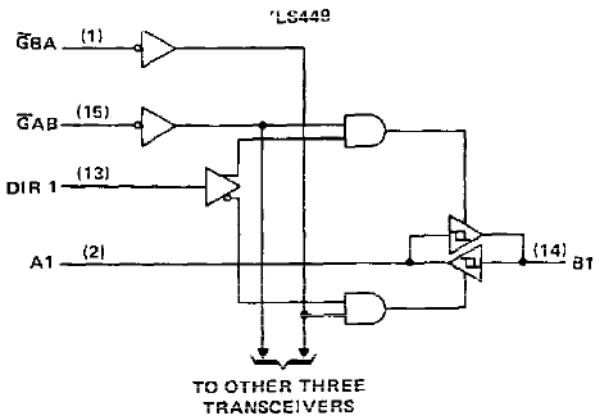
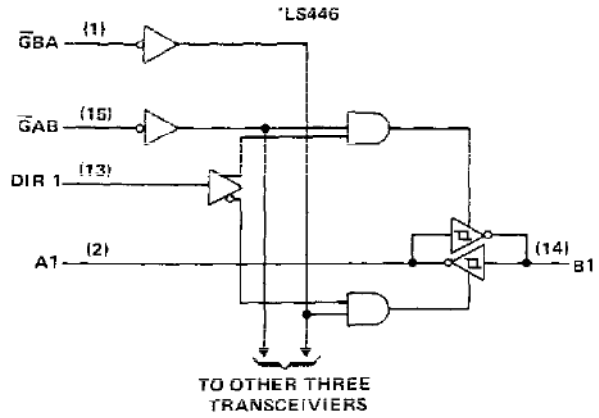

† These symbols are in accordance with ANSI/IEEE Std 91-1984 and IEC Publication 617-12. Pin numbers shown are for D, J, and N packages.

schematics of inputs and outputs

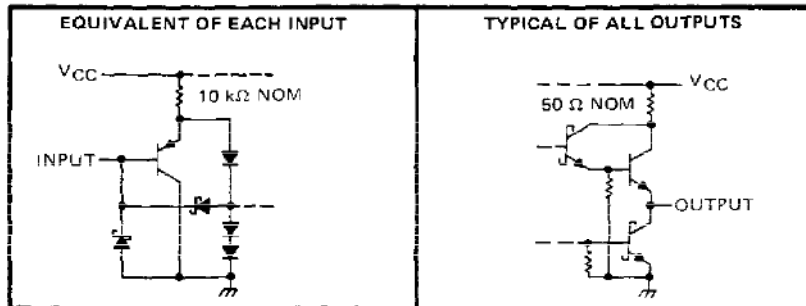

SN54LS446, SN54LS449, SN74LS446, SN74LS449 QUADRUPLE BUS TRANSCEIVERS WITH INDIVIDUAL DIRECTION CONTROLS

recommended operating conditions

PARAMETER	SN54LS446 SN54LS449			SN74LS446 SN74LS449			UNIT
	MIN	NOM	MAX	MIN	NOM	MAX	
Supply voltage, V_{CC} (see Note 1)	4.5	5	5.5	4.75	5	5.25	V
High-level output current, I_{OH}			-12			-15	mA
Low-level output current, I_{OL}			12			24	mA
Operating free-air temperature, T_A	-55		125	0		70	$^{\circ}$ C

NOTE 1: Voltage values are with respect to network ground terminal.

electrical characteristics over recommended operating free-air temperature range (unless otherwise noted)

PARAMETER	TEST CONDITIONS [†]	SN54LS446 SN54LS449		SN74LS446 SN74LS449		UNIT		
		MIN	TYP [‡]	MAX	MIN		TYP [‡]	MAX
V_{IH} High-level input voltage		2		2		V		
V_{IL} Low-level input voltage		0.6		0.7		V		
V_{IK} Input clamp voltage	$V_{CC} = \text{MIN}$, $I_I = -18 \text{ mA}$	-1.5		-1.5		V		
Hysteresis ($V_{T+} - V_{T-}$), A or B input	$V_{CC} = \text{MIN}$	0.1	0.4	0.2	0.4	V		
V_{OH} High-level output voltage	$V_{CC} = \text{MIN}$, $V_{IH} = 2 \text{ V}$, $V_{IL} = V_{IL \text{ max}}$	$I_{OH} = -3 \text{ mA}$ 2.4 3.4		$I_{OH} = -3 \text{ mA}$ 2.4 3.4		V		
		$I_{OH} = \text{MAX}$ 2		$I_{OH} = \text{MAX}$ 2				
V_{OL} Low-level output voltage	$V_{CC} = \text{MIN}$, $V_{IH} = 2 \text{ V}$, $V_{IL} = V_{IL \text{ max}}$	$I_{OL} = 12 \text{ mA}$ 0.25 0.4		$I_{OL} = 12 \text{ mA}$ 0.25 0.4		V		
		$I_{OL} = 24 \text{ mA}$ 0.35 0.5		$I_{OL} = 24 \text{ mA}$ 0.35 0.5				
I_{OZH} Off-state output current, high-level voltage applied	$V_{CC} = \text{MAX}$, \bar{G} at 2 V, $V_O = 2.7 \text{ V}$	20		20		μ A		
I_{OZL} Off-state output current, low-level voltage applied	$V_{CC} = \text{MAX}$, \bar{G} at 2 V, $V_O = 0.4 \text{ V}$	-0.4		-0.4		mA		
I_I Input current at maximum input voltage	A or B	$V_{CC} = \text{MAX}$, $V_I = 5.5 \text{ V}$		0.1		mA		
	$\bar{G}A$ or $\bar{G}B$	$V_{CC} = \text{MAX}$, $V_I = 7 \text{ V}$		0.1				
I_{IH} High-level input current	$V_{CC} = \text{MAX}$, $V_I = 2.7 \text{ V}$	20		20		μ A		
I_{IL} Low-level input current	$V_{CC} = \text{MAX}$, $V_I = 0.4 \text{ V}$	-0.4		-0.4		mA		
I_{OS} Short-circuit output current [§]	$V_{CC} = \text{MAX}$	-40	-225	-40	-225	mA		
I_{CC} Total supply current	'LS446	$V_{CC} = \text{MAX}$, Outputs open	Outputs high	35	56	35	56	mA
			Outputs low	39	63	39	63	
	Outputs at Hi-Z		42	68	42	68		
	'LS449		Outputs high	42	68	42	68	
			Outputs low	47	75	47	75	
	Outputs at Hi-Z		50	80	50	80		

[†] For conditions shown as MIN or MAX, use the appropriate value specified under recommended operating conditions.

[‡] All typical values are at $V_{CC} = 5 \text{ V}$, $T_A = 25^{\circ}\text{C}$.

[§] Not more than one output should be shorted at a time, and duration of the short-circuit should not exceed one second.

**TEXAS
INSTRUMENTS**

POST OFFICE BOX 665012 • DALLAS, TEXAS 75265

SN54LS446, SN54LS449, SN74LS446, SN74LS449
QUADRUPLE BUS TRANSCEIVERS WITH INDIVIDUAL DIRECTION CONTROLS

switching characteristics at $V_{CC} = 5\text{ V}$, $T_A = 25^\circ\text{C}$

PARAMETER	FROM (INPUT)	TO (OUTPUT)	TEST CONDITIONS	'LS446			'LS449			UNIT
				MIN	TYP	MAX	MIN	TYP	MAX	
t _{PLH} Propagation delay time, low-to-high-level output	A	B	C _L = 45 pF, R _L = 667 Ω, See Note 2	8	13		10	15	ns	
	B	A		8	13		10	15		
t _{PHL} Propagation delay time, high-to-low-level output	A	B		7	12		11	17	ns	
	B	A		7	12		11	17		
t _{PZL} Output enable time to low level	$\bar{G}BA$	A	24	40		21	35	ns		
	$\bar{G}AB$	B	24	40		21	35			
t _{PZH} Output enable time to high level	$\bar{G}BA$	A	15	25		18	30	ns		
	$\bar{G}AB$	B	15	25		18	30			
t _{PLZ} Output disable time from low level	$\bar{G}BA$	A	C _L = 5 pF, R _L = 667 Ω, See Note 2	14	25		14	25	ns	
	$\bar{G}AB$	B		14	25		14	25		
t _{PHZ} Output disable time from high level	$\bar{G}BA$	A		10	15		10	15	ns	
	$\bar{G}AB$	B		10	15		10	15		

NOTE 2: Load circuits and voltage waveforms are shown in Section 1.

TEXAS
INSTRUMENTS

POST OFFICE BOX 655012 • DALLAS, TEXAS 75265

IMPORTANT NOTICE

Texas Instruments (TI) reserves the right to make changes to its products or to discontinue any semiconductor product or service without notice, and advises its customers to obtain the latest version of relevant information to verify, before placing orders, that the information being relied on is current.

TI warrants performance of its semiconductor products and related software to the specifications applicable at the time of sale in accordance with TI's standard warranty. Testing and other quality control techniques are utilized to the extent TI deems necessary to support this warranty. Specific testing of all parameters of each device is not necessarily performed, except those mandated by government requirements.

Certain applications using semiconductor products may involve potential risks of death, personal injury, or severe property or environmental damage ("Critical Applications").

TI SEMICONDUCTOR PRODUCTS ARE NOT DESIGNED, INTENDED, AUTHORIZED, OR WARRANTED TO BE SUITABLE FOR USE IN LIFE-SUPPORT APPLICATIONS, DEVICES OR SYSTEMS OR OTHER CRITICAL APPLICATIONS.

Inclusion of TI products in such applications is understood to be fully at the risk of the customer. Use of TI products in such applications requires the written approval of an appropriate TI officer. Questions concerning potential risk applications should be directed to TI through a local SC sales office.

In order to minimize risks associated with the customer's applications, adequate design and operating safeguards should be provided by the customer to minimize inherent or procedural hazards.

TI assumes no liability for applications assistance, customer product design, software performance, or infringement of patents or services described herein. Nor does TI warrant or represent that any license, either express or implied, is granted under any patent right, copyright, mask work right, or other intellectual property right of TI covering or relating to any combination, machine, or process in which such semiconductor products or services might be or are used.

IMPORTANT NOTICE

Texas Instruments (TI) reserves the right to make changes to its products or to discontinue any semiconductor product or service without notice, and advises its customers to obtain the latest version of relevant information to verify, before placing orders, that the information being relied on is current.

TI warrants performance of its semiconductor products and related software to the specifications applicable at the time of sale in accordance with TI's standard warranty. Testing and other quality control techniques are utilized to the extent TI deems necessary to support this warranty. Specific testing of all parameters of each device is not necessarily performed, except those mandated by government requirements.

Certain applications using semiconductor products may involve potential risks of death, personal injury, or severe property or environmental damage ("Critical Applications").

TI SEMICONDUCTOR PRODUCTS ARE NOT DESIGNED, INTENDED, AUTHORIZED, OR WARRANTED TO BE SUITABLE FOR USE IN LIFE-SUPPORT APPLICATIONS, DEVICES OR SYSTEMS OR OTHER CRITICAL APPLICATIONS.

Inclusion of TI products in such applications is understood to be fully at the risk of the customer. Use of TI products in such applications requires the written approval of an appropriate TI officer. Questions concerning potential risk applications should be directed to TI through a local SC sales office.

In order to minimize risks associated with the customer's applications, adequate design and operating safeguards should be provided by the customer to minimize inherent or procedural hazards.

TI assumes no liability for applications assistance, customer product design, software performance, or infringement of patents or services described herein. Nor does TI warrant or represent that any license, either express or implied, is granted under any patent right, copyright, mask work right, or other intellectual property right of TI covering or relating to any combination, machine, or process in which such semiconductor products or services might be or are used.

IMPORTANT NOTICE

Texas Instruments and its subsidiaries (TI) reserve the right to make changes to their products or to discontinue any product or service without notice, and advise customers to obtain the latest version of relevant information to verify, before placing orders, that information being relied on is current and complete. All products are sold subject to the terms and conditions of sale supplied at the time of order acknowledgement, including those pertaining to warranty, patent infringement, and limitation of liability.

TI warrants performance of its semiconductor products to the specifications applicable at the time of sale in accordance with TI's standard warranty. Testing and other quality control techniques are utilized to the extent TI deems necessary to support this warranty. Specific testing of all parameters of each device is not necessarily performed, except those mandated by government requirements.

CERTAIN APPLICATIONS USING SEMICONDUCTOR PRODUCTS MAY INVOLVE POTENTIAL RISKS OF DEATH, PERSONAL INJURY, OR SEVERE PROPERTY OR ENVIRONMENTAL DAMAGE ("CRITICAL APPLICATIONS"). TI SEMICONDUCTOR PRODUCTS ARE NOT DESIGNED, AUTHORIZED, OR WARRANTED TO BE SUITABLE FOR USE IN LIFE-SUPPORT DEVICES OR SYSTEMS OR OTHER CRITICAL APPLICATIONS. INCLUSION OF TI PRODUCTS IN SUCH APPLICATIONS IS UNDERSTOOD TO BE FULLY AT THE CUSTOMER'S RISK.

In order to minimize risks associated with the customer's applications, adequate design and operating safeguards must be provided by the customer to minimize inherent or procedural hazards.

TI assumes no liability for applications assistance or customer product design. TI does not warrant or represent that any license, either express or implied, is granted under any patent right, copyright, mask work right, or other intellectual property right of TI covering or relating to any combination, machine, or process in which such semiconductor products or services might be or are used. TI's publication of information regarding any third party's products or services does not constitute TI's approval, warranty or endorsement thereof.