



MOTOROLA

DECADE COUNTER; 4-BIT BINARY COUNTER

The SN54/74LS290 and SN54/74LS293 are high-speed 4-bit ripple type counters partitioned into two sections. Each counter has a divide-by-two section and either a divide-by-five (LS290) or divide-by-eight (LS293) section which are triggered by a HIGH-to-LOW transition on the clock inputs. Each section can be used separately or tied together (Q to CP) to form BCD, Bi-quinary, or Modulo-16 counters. Both of the counters have a 2-input gated Master Reset (Clear), and the LS290 also has a 2-input gated Master Set (Preset 9).

- Corner Power Pin Versions of the LS90 and LS93
- Low Power Consumption . . . Typically 45 mW
- High Count Rates . . . Typically 42 MHz
- Choice of Counting Modes . . . BCD, Bi-Quinary, Binary
- Input Clamp Diodes Limit High Speed Termination Effects

CONNECTION DIAGRAM DIP (TOP VIEW)

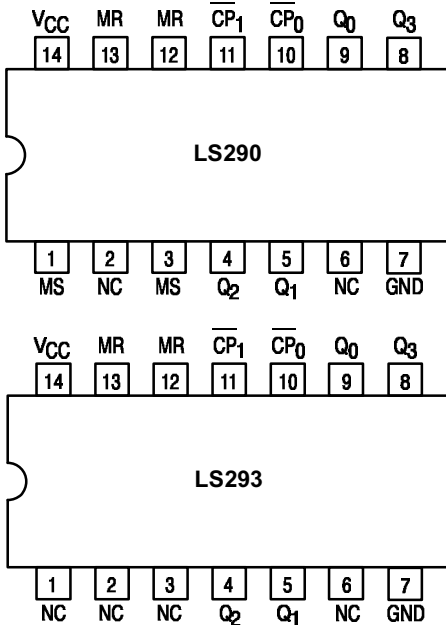

NOTE:
The Flatpak version has the same pinouts (Connection Diagram) as the Dual In-Line Package.

PIN NAMES

CP ₀	Clock (Active LOW going edge) Input to ÷2 Section.
CP ₁	Clock (Active LOW going edge) Input to ÷5 Section (LS290).
CP ₁	Clock (Active LOW going edge) Input to ÷8 Section (LS293).
MR1, MR2	Master Reset (Clear) Inputs
MS1, MS2	Master Set (Preset-9, LS290) Inputs
Q ₀	Output from ÷2 Section (Notes b & c)
Q ₁ , Q ₂ , Q ₃	Outputs from ÷5 & ÷8 Sections (Note b)

NOTES:

- 1 TTL Unit Load (U.L.) = 40 µA HIGH/1.6 mA LOW.
- The Output LOW drive factor is 2.5 U.L. for Military (54) and 5 U.L. for Commercial (74) Temperature Ranges.
- The Q₀ Outputs are guaranteed to drive the full fan-out plus the CP₁ Input of the device.

SN54/74LS290 SN54/74LS293

DECADE COUNTER; 4-BIT BINARY COUNTER LOW POWER SCHOTTKY

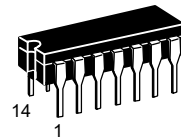

J SUFFIX
CERAMIC
CASE 632-08

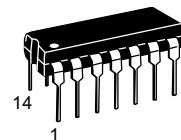

N SUFFIX
PLASTIC
CASE 646-06

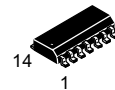

D SUFFIX
SOIC
CASE 751A-02

ORDERING INFORMATION

SN54LSXXXJ	Ceramic
SN74LSXXXN	Plastic
SN74LSXXXD	SOIC

LOADING (Note a)

HIGH	LOW
0.05 U.L.	1.5 U.L.
0.05 U.L.	2.0 U.L.
0.05 U.L.	1.0 U.L.
0.5 U.L.	0.25 U.L.
0.5 U.L.	0.25 U.L.
10 U.L.	5 (2.5) U.L.
10 U.L.	5 (2.5) U.L.

SN54/74LS290 • SN54/74LS293

LOGIC SYMBOL

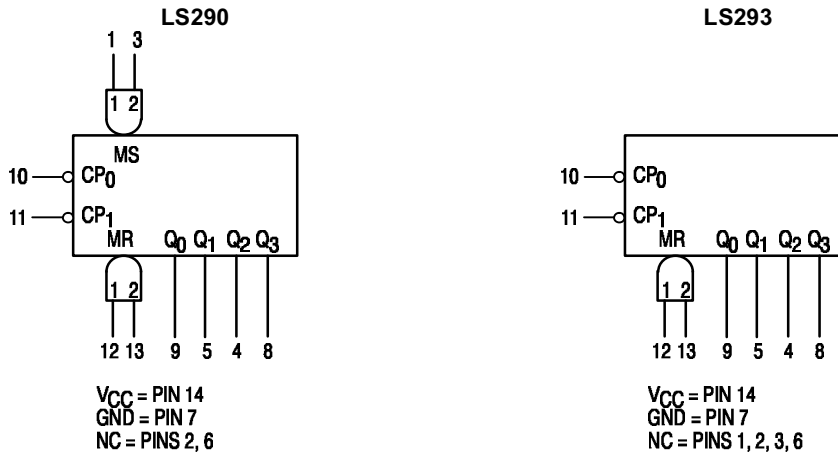

LOGIC DIAGRAMS

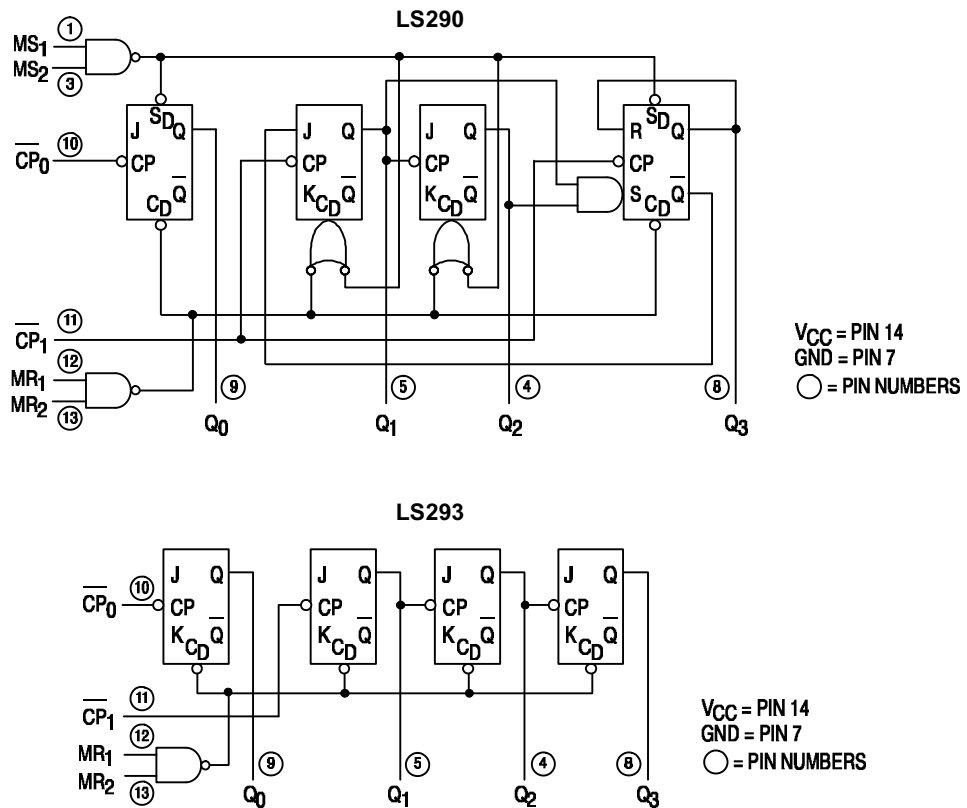

SN54/74LS290 • SN54/74LS293

FUNCTIONAL DESCRIPTION

The LS290 and LS293 are 4-bit ripple type Decade, and 4-Bit Binary counters respectively. Each device consists of four master/slave flip-flops which are internally connected to provide a divide-by-two section and a divide-by-five (LS290) or divide-by-eight (LS293) section. Each section has a separate clock input which initiates state changes of the counter on the HIGH-to-LOW clock transition. State changes of the Q outputs do not occur simultaneously because of internal ripple delays. Therefore, decoded output signals are subject to decoding spikes and should not be used for clocks or strobes. The Q₀ output of each device is designed and specified to drive the rated fan-out plus the CP₁ input of the device.

A gated AND asynchronous Master Reset (MR₁ · MR₂) is provided on both counters which overrides the clocks and resets (clears) all the flip-flops. A gated AND asynchronous Master Set (MS₁ · MS₂) is provided on the LS290 which overrides the clocks and the MR inputs and sets the outputs to nine (HLLH).

Since the output from the divide-by-two section is not internally connected to the succeeding stages, the devices may be operated in various counting modes:

LS290

A. BCD Decade (8421) Counter — the CP₁ input must be

externally connected to the Q₀ output. The CP₀ input receives the incoming count and a BCD count sequence is produced.

- B. Symmetrical Bi-quinary Divide-By-Ten Counter — The Q₃ output must be externally connected to the CP₀ input. The input count is then applied to the CP₁ input and a divide-by-ten square wave is obtained at output Q₀.
- C. Divide-By-Two and Divide-By-Five Counter — No external interconnections are required. The first flip-flop is used as a binary element for the divide-by-two function (CP₀ as the input and Q₀ as the output). The CP₁ input is used to obtain binary divide-by-five operation at the Q₃ output.

LS293

A. 4-Bit Ripple Counter — The output Q₀ must be externally connected to input CP₁. The input count pulses are applied to input CP₀. Simultaneous division of 2, 4, 8, and 16 are performed at the Q₀, Q₁, Q₂, and Q₃ outputs as shown in the truth table.

B. 3-Bit Ripple Counter — The input count pulses are applied to input CP₁. Simultaneous frequency divisions of 2, 4, and 8 are available at the Q₁, Q₂, and Q₃ outputs. Independent use of the first flip-flop is available if the reset function coincides with reset of the 3-bit ripple-through counter.

LS290 MODE SELECTION

RESET/SET INPUTS				OUTPUTS			
MR ₁	MR ₂	MS ₁	MS ₂	Q ₀	Q ₁	Q ₂	Q ₃
H	H	L	X	L	L	L	L
H	H	X	L	L	L	L	L
X	X	H	H	H	L	L	H
L	X	L	X			Count	
X	L	X	L			Count	
L	X	X	L			Count	
X	L	L	X			Count	

LS293 MODE SELECTION

RESET INPUTS		OUTPUTS			
MR ₁	MR ₂	Q ₀	Q ₁	Q ₂	Q ₃
H	H	L	L	L	L
L	H			Count	
H	L			Count	
L	L			Count	

LS290
BCD COUNT SEQUENCE

COUNT	OUTPUT			
	Q ₀	Q ₁	Q ₂	Q ₃
0	L	L	L	L
1	H	L	L	L
2	L	H	L	L
3	H	H	L	L
4	L	L	H	L
5	H	L	H	L
6	L	H	H	L
7	H	H	H	L
8	L	L	L	H
9	H	L	L	H

NOTE: Output Q₀ is connected to Input CP₁ for BCD count.

H = HIGH Voltage Level
L = LOW Voltage Level
X = Don't Care

TRUTH TABLE

COUNT	OUTPUT			
	Q ₀	Q ₁	Q ₂	Q ₃
0	L	L	L	L
1	H	L	L	L
2	L	H	L	L
3	H	H	L	L
4	L	L	H	L
5	H	L	H	L
6	L	H	H	L
7	H	H	H	L
8	L	L	L	H
9	H	L	L	H
10	L	H	L	H
11	H	H	L	H
12	L	L	H	H
13	H	L	H	H
14	L	H	H	H
15	H	H	H	H

Note: Output Q₀ connected to input CP₁.

SN54/74LS290 • SN54/74LS293

GUARANTEED OPERATING RANGES

Symbol	Parameter		Min	Typ	Max	Unit
V _{CC}	Supply Voltage	54	4.5	5.0	5.5	V
		74	4.75	5.0	5.25	
T _A	Operating Ambient Temperature Range	54	-55	25	125	°C
		74	0	25	70	
I _{OH}	Output Current — High	54, 74			-0.4	mA
I _{OL}	Output Current — Low	54			4.0	mA
		74			8.0	

DC CHARACTERISTICS OVER OPERATING TEMPERATURE RANGE (unless otherwise specified)

Symbol	Parameter	Limits			Unit	Test Conditions	
		Min	Typ	Max			
V _{IH}	Input HIGH Voltage	2.0			V	Guaranteed Input HIGH Voltage for All Inputs	
V _{IL}	Input LOW Voltage	54		0.7	V	Guaranteed Input LOW Voltage for All Inputs	
		74		0.8			
V _{IK}	Input Clamp Diode Voltage		-0.65	-1.5	V	V _{CC} = MIN, I _{IN} = -18 mA	
V _{OH}	Output HIGH Voltage	54	2.5	3.5	V	V _{CC} = MIN, I _{OH} = MAX, V _{IN} = V _{IH} or V _{IL} per Truth Table	
		74	2.7	3.5	V		
V _{OL}	Output LOW Voltage	54, 74		0.25	0.4	I _{OL} = 4.0 mA	V _{CC} = V _{CC} MIN, V _{IN} = V _{IL} or V _{IH} per Truth Table
		74		0.35	0.5	I _{OL} = 8.0 mA	
I _{IH}	Input HIGH Current			20	μA	V _{CC} = MAX, V _{IN} = 2.7 V	
				0.1	mA	V _{CC} = MAX, V _{IN} = 7.0 V	
I _{IL}	Input LOW Current MS, MR CP ₀ CP ₁ (LS290) CP ₁ (LS293)			-0.4 -2.4 -3.2 -1.6	mA	V _{CC} = MAX, V _{IN} = 0.4 V	
I _{OS}	Short Circuit Current (Note 1)	-20		-100	mA	V _{CC} = MAX	
I _{CC}	Power Supply Current			15	mA	V _{CC} = MAX	

Note 1: Not more than one output should be shorted at a time, nor for more than 1 second.

SN54/74LS290 • SN54/74LS293

AC CHARACTERISTICS ($T_A = 25^\circ\text{C}$, $V_{CC} = 5.0\text{ V}$, $C_L = 15\text{ pF}$)

Symbol	Parameter	Limits						Unit
		LS290			LS293			
		Min	Typ	Max	Min	Typ	Max	
f_{MAX}	CP ₀ Input Clock Frequency	32			32			MHz
f_{MAX}	CP ₁ Input Clock Frequency	16			16			MHz
t_{PLH} t_{PHL}	Propagation Delay, CP ₀ Input to Q ₀ Output		10 12	16 18		10 12	16 18	ns
t_{PLH} t_{PHL}	CP ₀ Input to Q ₃ Output		32 34	48 50		46 46	70 70	ns
t_{PLH} t_{PHL}	CP ₁ Input to Q ₁ Output		10 14	16 21		10 14	16 21	ns
t_{PLH} t_{PHL}	CP ₁ Input to Q ₂ Output		21 23	32 35		21 23	32 35	ns
t_{PLH} t_{PHL}	CP ₁ Input to Q ₃ Output		21 23	32 35		34 34	51 51	ns
t_{PHL}	MS Input to Q ₀ and Q ₃ Outputs		20	30				ns
t_{PHL}	MS Input to Q ₁ and Q ₂ Outputs		26	40				ns
t_{PHL}	MR Input to Any Output		26	40		26	40	ns

AC SETUP REQUIREMENTS ($T_A = 25^\circ\text{C}$, $V_{CC} = 5.0\text{ V}$)

Symbol	Parameter	Limits				Unit
		LS290		LS293		
		Min	Max	Min	Max	
t_W	CP ₀ Pulse Width	15		15		ns
t_W	CP ₁ Pulse Width	30		30		ns
t_W	MS Pulse Width	15				ns
t_W	MR Pulse Width	15		15		ns
t_{rec}	Recovery Time MR to CP	25		25		ns

RECOVERY TIME (t_{rec}) is defined as the minimum time required between the end of the reset pulse and the clock transition from HIGH-to-LOW in order to recognize and transfer HIGH data to the Q outputs.

AC WAVEFORMS

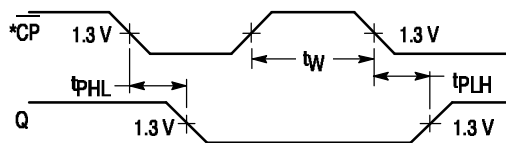

Figure 1

*The number of Clock Pulses required between the t_{PHL} and t_{PLH} measurements can be determined from the appropriate Truth Tables.

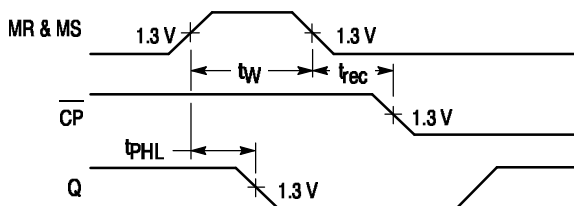

Figure 2

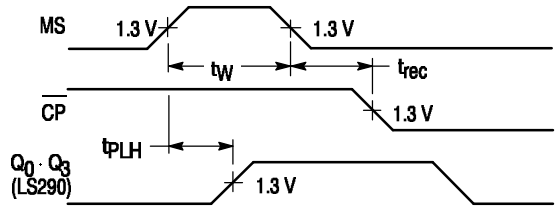
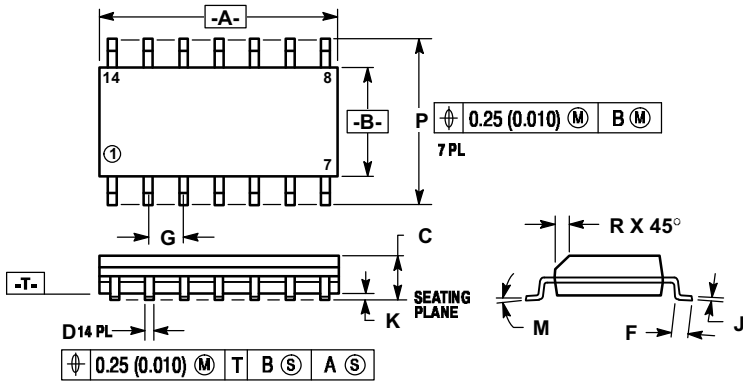

Figure 3

Case 751A-02 D Suffix
14-Pin Plastic
SO-14



- NOTES:
1. DIMENSIONS "A" AND "B" ARE DATUMS AND "T" IS A DATUM SURFACE.
 2. DIMENSIONING AND TOLERANCING PER ANSI Y14.5M, 1982.
 3. CONTROLLING DIMENSION: MILLIMETER.
 4. DIMENSION A AND B DO NOT INCLUDE MOLD PROTRUSION.
 5. MAXIMUM MOLD PROTRUSION 0.15 (0.006) PER SIDE.
 6. 751A-01 IS OBSOLETE, NEW STANDARD 751A-02.

DIM	MILLIMETERS		INCHES	
	MIN	MAX	MIN	MAX
A	8.55	8.75	0.337	0.344
B	3.80	4.00	0.150	0.157
C	1.35	1.75	0.054	0.068
D	0.35	0.49	0.014	0.019
F	0.40	1.25	0.016	0.049
G	1.27 BSC		0.050 BSC	
J	0.19	0.25	0.008	0.009
K	0.10	0.25	0.004	0.009
M	0°	7°	0°	7°
P	5.80	6.20	0.228	0.244
R	0.25	0.50	0.010	0.019

Case 632-08 J Suffix
14-Pin Ceramic Dual In-Line

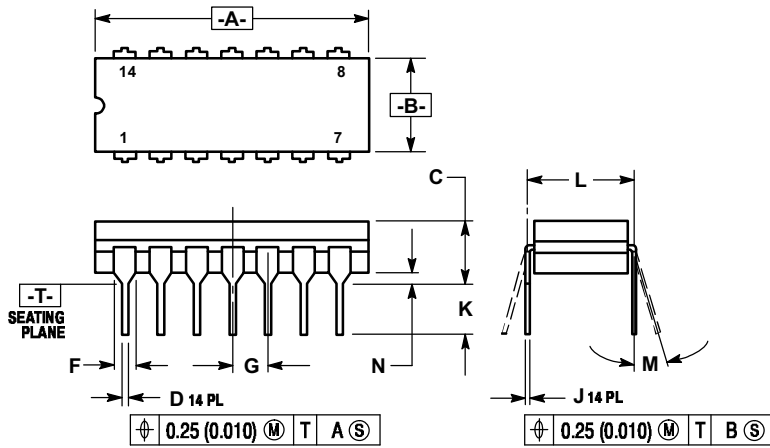

- NOTES:
1. DIMENSIONING AND TOLERANCING PER ANSI Y14.5M, 1982.
 2. CONTROLLING DIMENSION: INCH.
 3. DIMENSION L TO CENTER OF LEAD WHEN FORMED PARALLEL.
 4. DIM F MAY NARROW TO 0.76 (0.030) WHERE THE LEAD ENTERS THE CERAMIC BODY.
 5. 632-01 THRU 07 OBSOLETE, NEW STANDARD 632-08.

DIM	MILLIMETERS		INCHES	
	MIN	MAX	MIN	MAX
A	19.05	19.94	0.750	0.785
B	6.23	7.11	0.245	0.280
C	3.94	5.08	0.155	0.200
D	0.39	0.50	0.015	0.020
F	1.40	1.65	0.055	0.065
G	2.54 BSC		0.100 BSC	
J	0.21	0.38	0.008	0.015
K	3.18	4.31	0.125	0.170
L	7.62 BSC		0.300 BSC	
M	0°	15°	0°	15°
N	0.51	1.01	0.020	0.040

Case 646-06 N Suffix
14-Pin Plastic

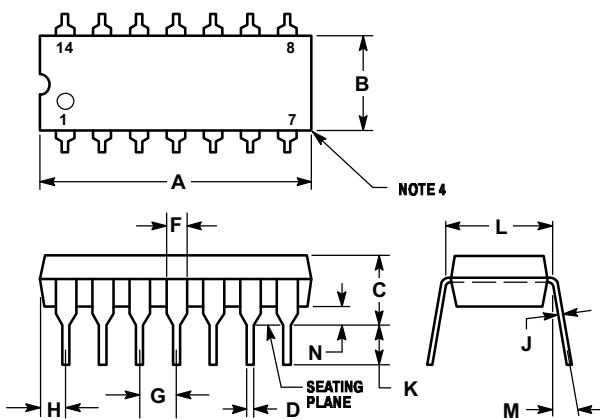

- NOTES:
1. LEADS WITHIN 0.13 mm (0.005) RADIUS OF TRUE POSITION AT SEATING PLANE AT MAXIMUM MATERIAL CONDITION.
 2. DIMENSION "L" TO CENTER OF LEADS WHEN FORMED PARALLEL.
 3. DIMENSION "B" DOES NOT INCLUDE MOLD FLASH.
 4. ROUNDED CORNERS OPTIONAL.
 5. 646-05 OBSOLETE, NEW STANDARD 646-06.

DIM	MILLIMETERS		INCHES	
	MIN	MAX	MIN	MAX
A	18.16	19.56	0.715	0.770
B	6.10	6.60	0.240	0.260
C	3.69	4.69	0.145	0.185
D	0.38	0.53	0.015	0.021
F	1.02	1.78	0.040	0.070
G	2.54 BSC		0.100 BSC	
H	1.32	2.41	0.052	0.095
J	0.20	0.38	0.008	0.015
K	2.92	3.43	0.115	0.135
L	7.62 BSC		0.300 BSC	
M	0°	10°	0°	10°
N	0.39	1.01	0.015	0.039

Motorola reserves the right to make changes without further notice to any products herein. Motorola makes no warranty, representation or guarantee regarding the suitability of its products for any particular purpose, nor does Motorola assume any liability arising out of the application or use of any product or circuit, and specifically disclaims any and all liability, including without limitation consequential or incidental damages. "Typical" parameters can and do vary in different applications. All operating parameters, including "Typicals" must be validated for each customer application by customer's technical experts. Motorola does not convey any license under its patent rights nor the rights of others. Motorola products are not designed, intended, or authorized for use as components in systems intended for surgical implant into the body, or other applications intended to support or sustain life, or for any other application in which the failure of the Motorola product could create a situation where personal injury or death may occur. Should Buyer purchase or use Motorola products for any such unintended or unauthorized application, Buyer shall indemnify and hold Motorola and its officers, employees, subsidiaries, affiliates, and distributors harmless against all claims, costs, damages, and expenses, and reasonable attorney fees arising out of, directly or indirectly, any claim of personal injury or death associated with such unintended or unauthorized use, even if such claim alleges that Motorola was negligent regarding the design or manufacture of the part. Motorola and  are registered trademarks of Motorola, Inc. Motorola, Inc. is an Equal Opportunity/Affirmative Action Employer.

Literature Distribution Centers:

USA: Motorola Literature Distribution; P.O. Box 20912; Phoenix, Arizona 85036.

EUROPE: Motorola Ltd.; European Literature Centre; 88 Tanners Drive, Blakelands, Milton Keynes, MK14 5BP, England.

JAPAN: Nippon Motorola Ltd.; 4-32-1, Nishi-Gotanda, Shinagawa-ku, Tokyo 141, Japan.

ASIA PACIFIC: Motorola Semiconductors H.K. Ltd.; Silicon Harbour Center, No. 2 Dai King Street, Tai Po Industrial Estate, Tai Po, N.T., Hong Kong.

