



RETRIGGERABLE MONOSTABLE MULTIVIBRATORS

These dc triggered multivibrators feature pulse width control by three methods. The basic pulse width is programmed by selection of external resistance and capacitance values. The LS122 has an internal timing resistor that allows the circuits to be used with only an external capacitor. Once triggered, the basic pulse width may be extended by retriggering the gated low-level-active (A) or high-level-active (B) inputs, or be reduced by use of the overriding clear.

- Overriding Clear Terminates Output Pulse
- Compensated for V_{CC} and Temperature Variations
- DC Triggered from Active-High or Active-Low Gated Logic Inputs
- Retriggerable for Very Long Output Pulses, up to 100% Duty Cycle
- Internal Timing Resistors on LS122

SN54/74LS123 (TOP VIEW)
(SEE NOTES 1 THRU 4)

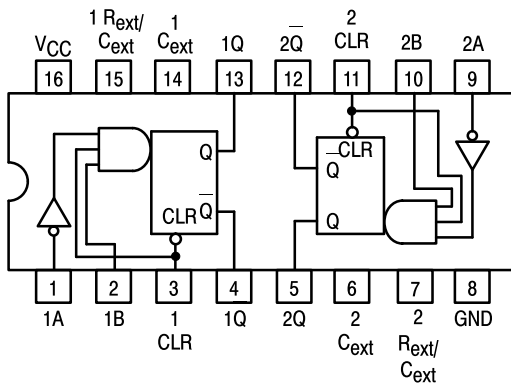

SN54/74LS122 (TOP VIEW)
(SEE NOTES 1 THRU 4)

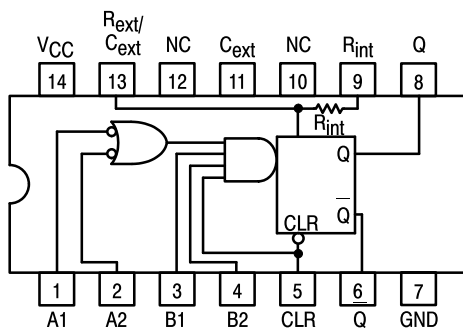

NC — NO INTERNAL CONNECTION.

NOTES:

1. An external timing capacitor may be connected between C_{ext} and R_{ext}/C_{ext} (positive).
2. To use the internal timing resistor of the LS122, connect R_{int} to V_{CC} .
3. For improved pulse width accuracy connect an external resistor between R_{ext}/C_{ext} and V_{CC} with R_{int} open-circuited.
4. To obtain variable pulse widths, connect an external variable resistance between R_{int}/C_{ext} and V_{CC} .

SN54/74LS122 SN54/74LS123

RETRIGGERABLE MONOSTABLE MULTIVIBRATORS LOW POWER SCHOTTKY

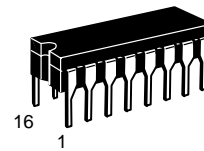

J SUFFIX
CERAMIC
CASE 620-09

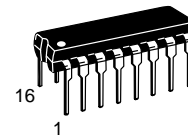

N SUFFIX
PLASTIC
CASE 648-08

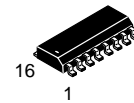

D SUFFIX
SOIC
CASE 751B-03

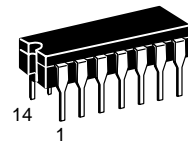

J SUFFIX
CERAMIC
CASE 632-08

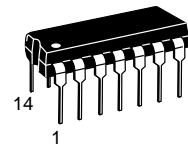

N SUFFIX
PLASTIC
CASE 646-06

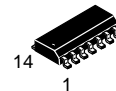

D SUFFIX
SOIC
CASE 751A-02

ORDERING INFORMATION

- SN54LSXXXJ Ceramic
- SN74LSXXXN Plastic
- SN74LSXXXD SOIC

SN54/74LS122 • SN54/74LS123

**LS122
FUNCTIONAL TABLE**

INPUTS					OUTPUTS	
CLEAR	A1	A2	B1	B2	Q	Q
L	X	X	X	X	L	H
X	H	H	X	X	L	H
X	X	X	L	X	L	H
X	X	X	X	L	L	H
H	L	X	↑	H		
H	L	X	H	↑		
H	X	L	↑	H		
H	X	L	H	↑		
H	H	↓	H	H		
H	↓	↓	H	H		
H	↓	H	H	H		
↑	L	X	H	H		
↑	X	L	H	H		

**LS123
FUNCTIONAL TABLE**

INPUTS			OUTPUTS	
CLEAR	A	B	Q	Q
L	X	X	L	H
X	H	X	L	H
X	X	L	L	H
H	L	↑		
H	↓	H		
↑	L	H		

TYPICAL APPLICATION DATA

The output pulse t_W is a function of the external components, C_{ext} and R_{ext} or C_{ext} and R_{int} on the LS122. For values of $C_{ext} \geq 1000$ pF, the output pulse at $V_{CC} = 5.0$ V and $V_{RC} = 5.0$ V (see Figures 1, 2, and 3) is given by

$$t_W = K R_{ext} C_{ext} \text{ where } K \text{ is nominally } 0.45$$

If C_{ext} is in pF and R_{ext} is in k Ω then t_W is in nanoseconds.

The C_{ext} terminal of the LS122 and LS123 is an internal connection to ground, however for the best system performance C_{ext} should be hard-wired to ground.

Care should be taken to keep R_{ext} and C_{ext} as close to the monostable as possible with a minimum amount of inductance between the R_{ext}/C_{ext} junction and the R_{ext}/C_{ext} pin. Good groundplane and adequate bypassing should be designed into the system for optimum performance to insure that no false triggering occurs.

It should be noted that the C_{ext} pin is internally connected to ground on the LS122 and LS123, but not on the LS221. Therefore, if C_{ext} is hard-wired externally to ground, substitution of a LS221 onto a LS123 socket will cause the LS221 to become non-functional.

The switching diode is not needed for electrolytic capacitance application and should not be used on the LS122 and LS123.

To find the value of K for $C_{ext} \geq 1000$ pF, refer to Figure 4. Variations on V_{CC} or V_{RC} can cause the value of K to change, as can the temperature of the LS123, LS122. Figures 5 and 6 show the behavior of the circuit shown in Figures 1 and 2 if

separate power supplies are used for V_{CC} and V_{RC} . If V_{CC} is tied to V_{RC} , Figure 7 shows how K will vary with V_{CC} and temperature. Remember, the changes in R_{ext} and C_{ext} with temperature are not calculated and included in the graph.

As long as $C_{ext} \geq 1000$ pF and $5K \leq R_{ext} \leq 260K$ (SN74LS122/123) or $5K \leq R_{ext} \leq 160K$ (SN54LS122/123), the change in K with respect to R_{ext} is negligible.

If $C_{ext} \leq 1000$ pF the graph shown on Figure 8 can be used to determine the output pulse width. Figure 9 shows how K will change for $C_{ext} \leq 1000$ pF if V_{CC} and V_{RC} are connected to the same power supply. The pulse width t_W in nanoseconds is approximated by

$$t_W = 6 + 0.05 C_{ext} (\text{pF}) + 0.45 R_{ext} (\text{k}\Omega) C_{ext} + 11.6 R_{ext}$$

In order to trim the output pulse width, it is necessary to include a variable resistor between V_{CC} and the R_{ext}/C_{ext} pin or between V_{CC} and the R_{ext} pin of the LS122. Figure 10, 11, and 12 show how this can be done. R_{ext} remote should be kept as close to the monostable as possible.

Retriggering of the part, as shown in Figure 3, must not occur before C_{ext} is discharged or the retrigger pulse will not have any effect. The discharge time of C_{ext} in nanoseconds is guaranteed to be less than $0.22 C_{ext}$ (pF) and is typically $0.05 C_{ext}$ (pF).

For the smallest possible deviation in output pulse widths from various devices, it is suggested that C_{ext} be kept ≥ 1000 pF.

SN54/74LS122 • SN54/74LS123

GUARANTEED OPERATING RANGES

Symbol	Parameter		Min	Typ	Max	Unit
V _{CC}	Supply Voltage	54 74	4.5 4.75	5.0 5.0	5.5 5.25	V
T _A	Operating Ambient Temperature Range	54 74	-55 0	25 25	125 70	°C
I _{OH}	Output Current — High	54, 74			-0.4	mA
I _{OL}	Output Current — Low	54 74			4.0 8.0	mA
R _{ext}	External Timing Resistance	54 74	5.0 5.0		180 260	kΩ
C _{ext}	External Capacitance	54, 74	No Restriction			
R _{ext} /C _{ext}	Wiring Capacitance at R _{ext} /C _{ext} Terminal	54, 74			50	pF

WAVEFORMS

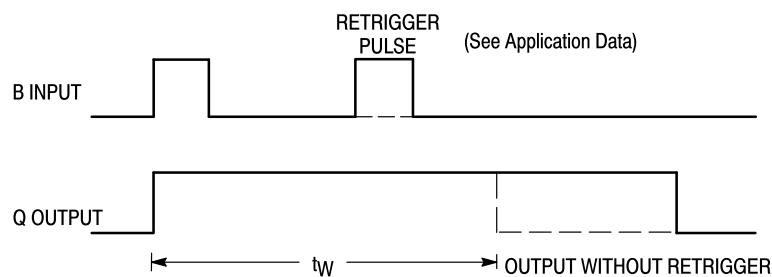

EXTENDING PULSE WIDTH

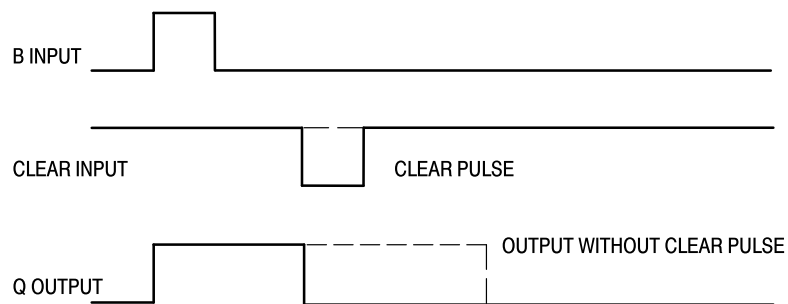

OVERRIDING THE OUTPUT PULSE

SN54/74LS122 • SN54/74LS123

DC CHARACTERISTICS OVER OPERATING TEMPERATURE RANGE (unless otherwise specified)

Symbol	Parameter		Limits			Unit	Test Conditions
			Min	Typ	Max		
V _{IH}	Input HIGH Voltage		2.0			V	Guaranteed Input HIGH Voltage for All Inputs
V _{IL}	Input LOW Voltage	54			0.7	V	Guaranteed Input LOW Voltage for All Inputs
		74			0.8		
V _{IK}	Input Clamp Diode Voltage			-0.65	-1.5	V	V _{CC} = MIN, I _{IN} = -18 mA
V _{OH}	Output HIGH Voltage	54	2.5	3.5		V	V _{CC} = MIN, I _{OH} = MAX, V _{IN} = V _{IH} or V _{IL} per Truth Table
		74	2.7	3.5		V	
V _{OL}	Output LOW Voltage	54, 74		0.25	0.4	V	I _{OL} = 4.0 mA V _{CC} = V _{CC} MIN, V _{IN} = V _{IL} or V _{IH} per Truth Table
		74		0.35	0.5	V	
I _{IH}	Input HIGH Current				20	μA	V _{CC} = MAX, V _{IN} = 2.7 V
					0.1	mA	V _{CC} = MAX, V _{IN} = 7.0 V
I _{IL}	Input LOW Current				-0.4	mA	V _{CC} = MAX, V _{IN} = 0.4 V
I _{OS}	Short Circuit Current (Note 1)		-20		-100	mA	V _{CC} = MAX
I _{CC}	Power Supply Current	LS122			11	mA	V _{CC} = MAX
		LS123			20		

Note 1: Not more than one output should be shorted at a time, nor for more than 1 second.

AC CHARACTERISTICS (T_A = 25°C, V_{CC} = 5.0 V)

Symbol	Parameter		Limits			Unit	Test Conditions
			Min	Typ	Max		
t _{PLH} t _{PHL}	Propagation Delay, A to Q Propagation Delay, A to Q			23 32	33 45	ns	C _{ext} = 0 C _L = 15 pF R _{ext} = 5.0 kΩ R _L = 2.0 kΩ
t _{PLH} t _{PHL}	Propagation Delay, B to Q Propagation Delay, B to Q			23 34	44 56		
t _{PLH} t _{PHL}	Propagation Delay, Clear to Q Propagation Delay, Clear to Q			28 20	45 27	ns	
t _{W min}	A or B to Q			116	200		
t _{WQ}	A to B to Q		4.0	4.5	5.0	μs	

AC SETUP REQUIREMENTS (T_A = 25°C, V_{CC} = 5.0 V)

Symbol	Parameter		Limits			Unit	Test Conditions
			Min	Typ	Max		
t _W	Pulse Width		40			ns	

SN54/74LS122 • SN54/74LS123

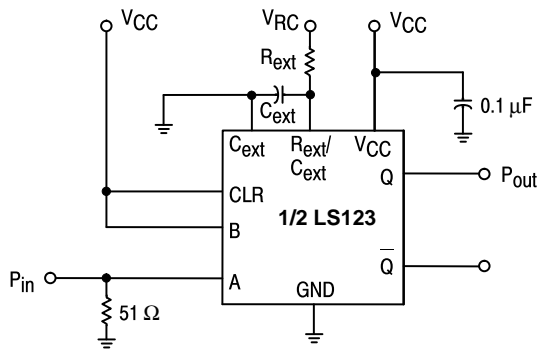

Figure 1

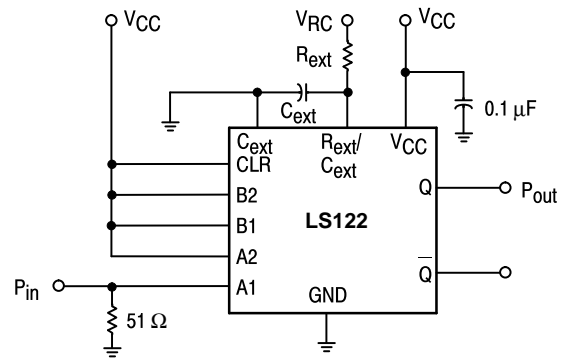

Figure 2

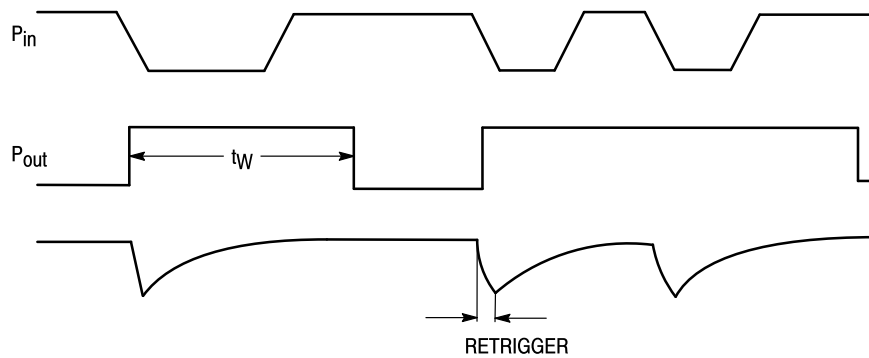

Figure 3

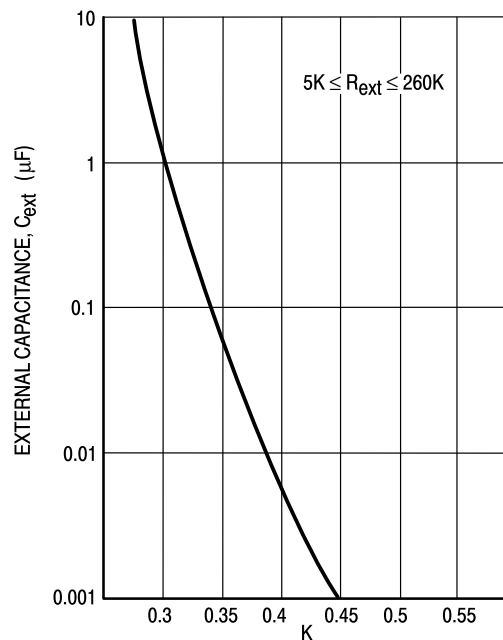

Figure 4

SN54/74LS122 • SN54/74LS123

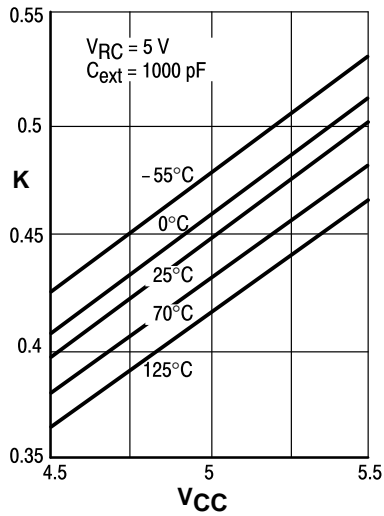

Figure 5. K versus V_{CC}

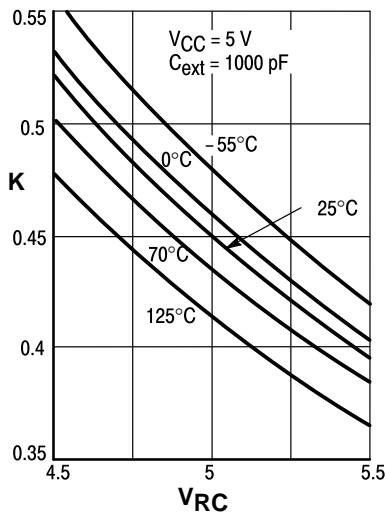

Figure 6. K versus V_{RC}

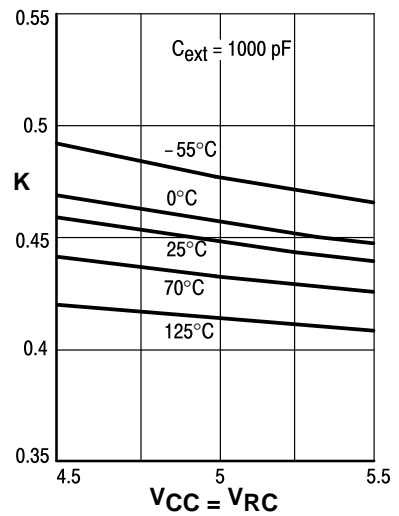

Figure 7. K versus V_{CC} and V_{RC}

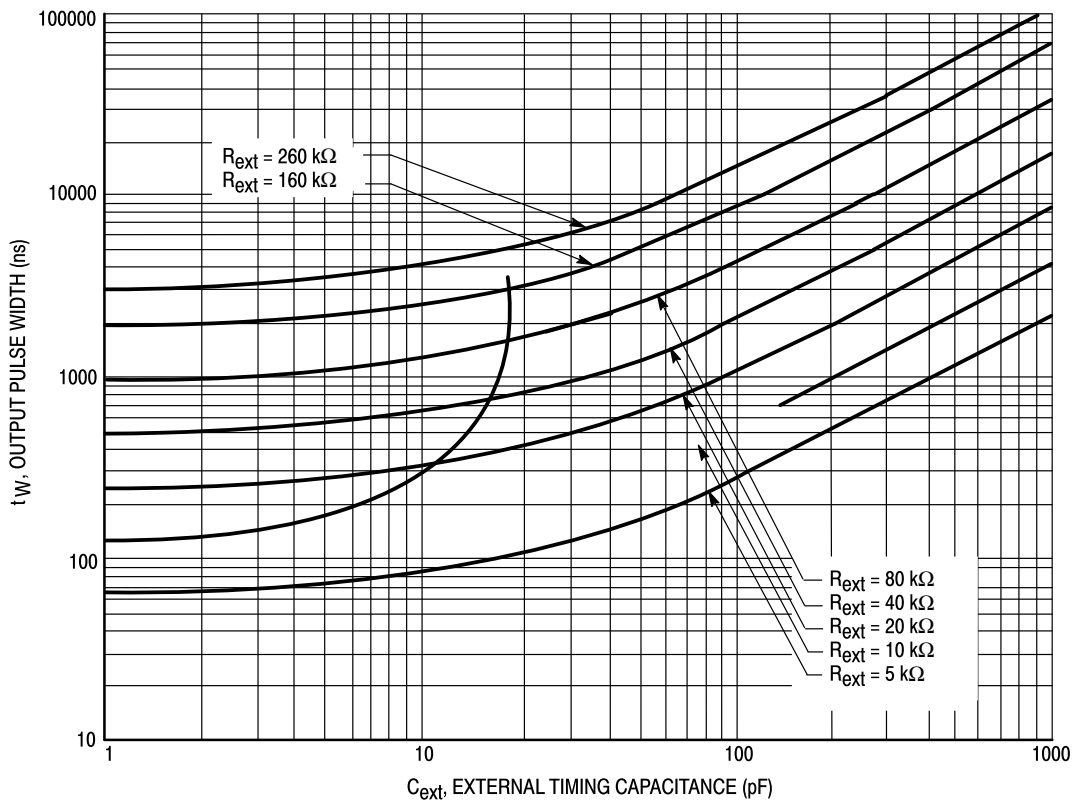

Figure 8

SN54/74LS122 • SN54/74LS123

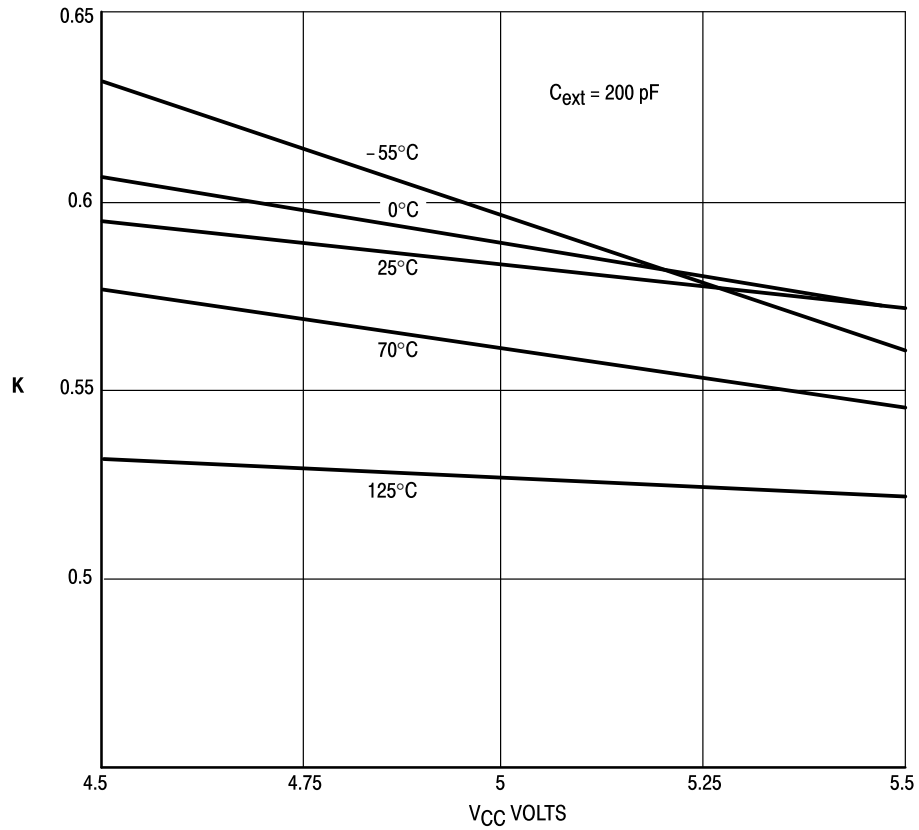

Figure 9

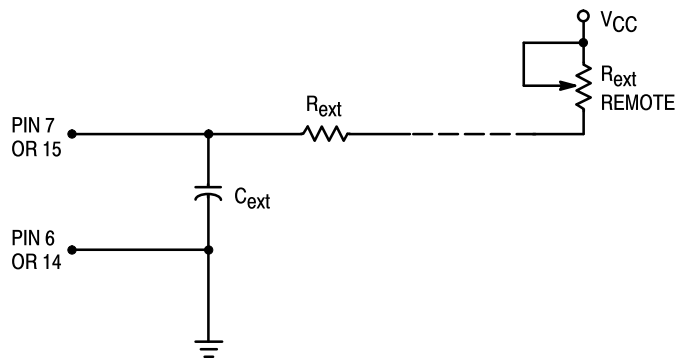

Figure 10. LS123 Remote Trimming Circuit

SN54/74LS122 • SN54/74LS123

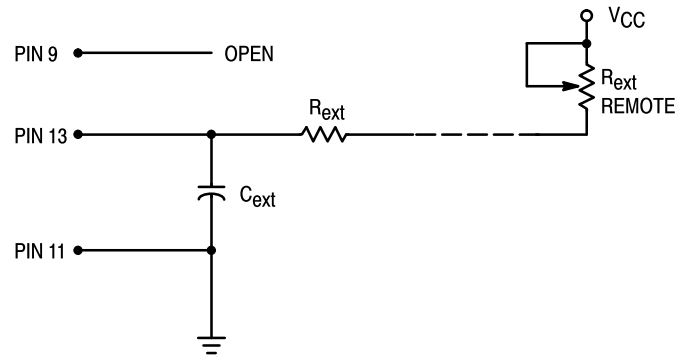

Figure 11. LS122 Remote Trimming Circuit Without R_{ext}

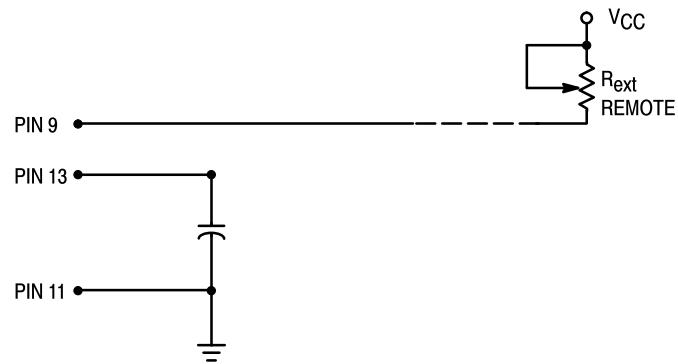
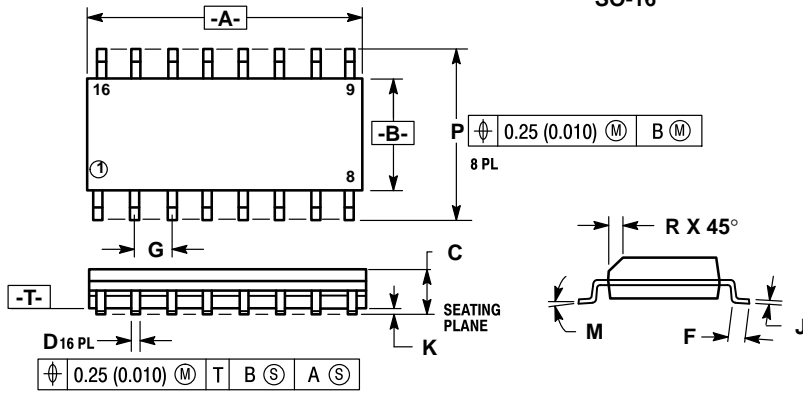

Figure 12. LS122 Remote Trimming Circuit with R_{int}

**Case 751B-03 D Suffix
16-Pin Plastic
SO-16**



- NOTES:
1. DIMENSIONING AND TOLERANCING PER ANSI Y14.5M, 1982.
 2. CONTROLLING DIMENSION: MILLIMETER.
 3. DIMENSION A AND B DO NOT INCLUDE MOLD PROTRUSION.
 4. MAXIMUM MOLD PROTRUSION 0.15 (0.006) PER SIDE.
 5. 751B-01 IS OBSOLETE, NEW STANDARD 751B-03.

DIM	MILLIMETERS		INCHES	
	MIN	MAX	MIN	MAX
A	9.80	10.00	0.386	0.393
B	3.80	4.00	0.150	0.157
C	1.35	1.75	0.054	0.068
D	0.35	0.49	0.014	0.019
F	0.40	1.25	0.016	0.049
G	1.27 BSC		0.050 BSC	
J	0.19	0.25	0.008	0.009
K	0.10	0.25	0.004	0.009
M	0°	7°	0°	7°
P	5.80	6.20	0.229	0.244
R	0.25	0.50	0.010	0.019

**Case 648-08 N Suffix
16-Pin Plastic**

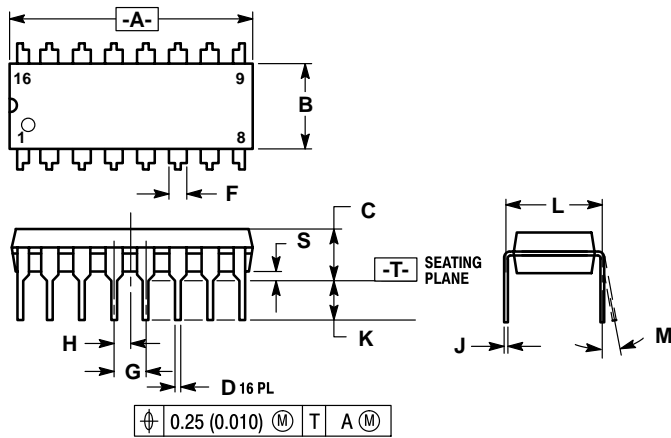

- NOTES:
1. DIMENSIONING AND TOLERANCING PER ANSI Y14.5M, 1982.
 2. CONTROLLING DIMENSION: INCH.
 3. DIMENSION "L" TO CENTER OF LEADS WHEN FORMED PARALLEL.
 4. DIMENSION "B" DOES NOT INCLUDE MOLD FLASH.
 5. ROUNDED CORNERS OPTIONAL.
 6. 648-01 THRU -07 OBSOLETE, NEW STANDARD 648-08.

DIM	MILLIMETERS		INCHES	
	MIN	MAX	MIN	MAX
A	18.80	19.55	0.740	0.770
B	6.35	6.85	0.250	0.270
C	3.69	4.44	0.145	0.175
D	0.39	0.53	0.015	0.021
F	1.02	1.77	0.040	0.070
G	2.54 BSC		0.100 BSC	
H	1.27 BSC		0.050 BSC	
J	0.21	0.38	0.008	0.015
K	2.80	3.30	0.110	0.130
L	7.50	7.74	0.295	0.305
M	0°	10°	0°	10°
S	0.51	1.01	0.020	0.040

**Case 620-09 J Suffix
16-Pin Ceramic Dual In-Line**

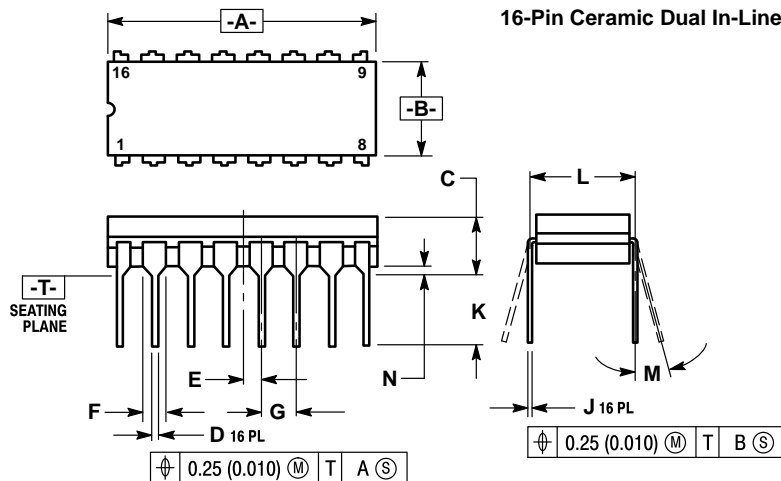

- NOTES:
1. DIMENSIONING AND TOLERANCING PER ANSI Y14.5M, 1982.
 2. CONTROLLING DIMENSION: INCH.
 3. DIMENSION L TO CENTER OF LEAD WHEN FORMED PARALLEL.
 4. DIM F MAY NARROW TO 0.76 (0.030) WHERE THE LEAD ENTERS THE CERAMIC BODY.
 5. 620-01 THRU -08 OBSOLETE, NEW STANDARD 620-09.

DIM	MILLIMETERS		INCHES	
	MIN	MAX	MIN	MAX
A	19.05	19.55	0.750	0.770
B	6.10	7.36	0.240	0.290
C	—	4.19	—	0.165
D	0.39	0.53	0.015	0.021
E	1.27 BSC		0.050 BSC	
F	1.40	1.77	0.055	0.070
G	2.54 BSC		0.100 BSC	
J	0.23	0.27	0.009	0.011
K	—	5.08	—	0.200
L	7.62 BSC		0.300 BSC	
M	0°	15°	0°	15°
N	0.39	0.88	0.015	0.035

Motorola reserves the right to make changes without further notice to any products herein. Motorola makes no warranty, representation or guarantee regarding the suitability of its products for any particular purpose, nor does Motorola assume any liability arising out of the application or use of any product or circuit, and specifically disclaims any and all liability, including without limitation consequential or incidental damages. "Typical" parameters can and do vary in different applications. All operating parameters, including "Typicals" must be validated for each customer application by customer's technical experts. Motorola does not convey any license under its patent rights nor the rights of others. Motorola products are not designed, intended, or authorized for use as components in systems intended for surgical implant into the body, or other applications intended to support or sustain life, or for any other application in which the failure of the Motorola product could create a situation where personal injury or death may occur. Should Buyer purchase or use Motorola products for any such unintended or unauthorized application, Buyer shall indemnify and hold Motorola and its officers, employees, subsidiaries, affiliates, and distributors harmless against all claims, costs, damages, and expenses, and reasonable attorney fees arising out of, directly or indirectly, any claim of personal injury or death associated with such unintended or unauthorized use, even if such claim alleges that Motorola was negligent regarding the design or manufacture of the part. Motorola and  are registered trademarks of Motorola, Inc. Motorola, Inc. is an Equal Opportunity/Affirmative Action Employer.

Literature Distribution Centers:

USA: Motorola Literature Distribution; P.O. Box 20912; Phoenix, Arizona 85036.

EUROPE: Motorola Ltd.; European Literature Centre; 88 Tanners Drive, Blakelands, Milton Keynes, MK14 5BP, England.

JAPAN: Nippon Motorola Ltd.; 4-32-1, Nishi-Gotanda, Shinagawa-ku, Tokyo 141, Japan.

ASIA PACIFIC: Motorola Semiconductors H.K. Ltd.; Silicon Harbour Center, No. 2 Dai King Street, Tai Po Industrial Estate, Tai Po, N.T., Hong Kong.

