

- Standard '244-Type Pinout
- 5-Ω Switch Connection Between Two Ports
- TTL-Compatible Input Levels

DB, DBQ, DGV, DW, OR PW PACKAGE
(TOP VIEW)

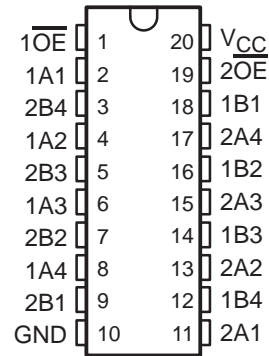

description

The SN74CBT3244 provides eight bits of high-speed TTL-compatible bus switching in a standard '244 device pinout. The low on-state resistance of the switch allows connections to be made with minimal propagation delay.

The device is organized as two 4-bit low-impedance switches with separate output-enable (\overline{OE}) inputs. When \overline{OE} is low, the switch is on, and data can flow from port A to port B, or vice versa. When \overline{OE} is high, the switch is open, and the high-impedance state exists between the two ports.

ORDERING INFORMATION

T _A	PACKAGE†		ORDERABLE PART NUMBER	TOP-SIDE MARKING
-40°C to 85°C	SOIC – DW	Tube	SN74CBT3244DW	CBT3244
		Tape and reel	SN74CBT3244DWR	
	SSOP – DB	Tape and reel	SN74CBT3244DBR	CU244
	SSOP (QSOP) – DBQ	Tape and reel	SN74CBT3244DBQR	CBT3244 or CU244
	TSSOP – PW	Tape and reel	SN74CBT3244PWR	CU244
	TVSOP – DGV	Tape and reel	SN74CBT3244DGVR	CU244

† Package drawings, standard packing quantities, thermal data, symbolization, and PCB design guidelines are available at www.ti.com/sc/package.

FUNCTION TABLE
(each 4-bit bus switch)

INPUT \overline{OE}	FUNCTION
L	A port = B port
H	Disconnect



Please be aware that an important notice concerning availability, standard warranty, and use in critical applications of Texas Instruments semiconductor products and disclaimers thereto appears at the end of this data sheet.

PRODUCTION DATA information is current as of publication date. Products conform to specifications per the terms of Texas Instruments standard warranty. Production processing does not necessarily include testing of all parameters.

**TEXAS
INSTRUMENTS**

POST OFFICE BOX 655303 • DALLAS, TEXAS 75265

Copyright © 2000, Texas Instruments Incorporated

SN74CBT3244 OCTAL FET BUS SWITCH

SCDS001J – NOVEMBER 1992 – REVISED OCTOBER 2000

logic diagram (positive logic)

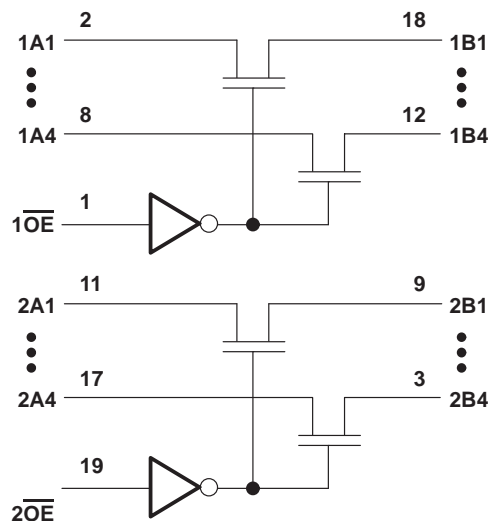

absolute maximum ratings over operating free-air temperature range (unless otherwise noted)†

Supply voltage range, V_{CC}	-0.5 V to 7 V
Input voltage range, V_I (see Note 1)	-0.5 V to 7 V
Continuous channel current	128 mA
Clamp current, I_K ($V_{I/O} < 0$)	-50 mA
Package thermal impedance, θ_{JA} (see Note 2): DB package	70°C/W
DBQ package	68°C/W
DGV package	92°C/W
DW package	58°C/W
PW package	83°C/W
Storage temperature range, T_{stg}	-65°C to 150°C

† Stresses beyond those listed under “absolute maximum ratings” may cause permanent damage to the device. These are stress ratings only, and functional operation of the device at these or any other conditions beyond those indicated under “recommended operating conditions” is not implied. Exposure to absolute-maximum-rated conditions for extended periods may affect device reliability.

- NOTES: 1. The input and output negative-voltage ratings may be exceeded if the input and output clamp-current ratings are observed.
2. The package thermal impedance is calculated in accordance with JESD 51-7.

recommended operating conditions (see Note 3)

	MIN	MAX	UNIT
V_{CC} Supply voltage	4.5	5.5	V
V_{IH} High-level control input voltage	2		V
V_{IL} Low-level control input voltage		0.8	V
T_A Operating free-air temperature	0	70	°C

NOTE 3: All unused control inputs of the device must be held at V_{CC} or GND to ensure proper device operation. Refer to the TI application report, *Implications of Slow or Floating CMOS Inputs*, literature number SCBA004.



POST OFFICE BOX 655303 • DALLAS, TEXAS 75265

electrical characteristics over recommended operating free-air temperature range (unless otherwise noted)

PARAMETER		TEST CONDITIONS		MIN	TYP†	MAX	UNIT
V_{IK}		$V_{CC} = 4.5\text{ V}$,	$I_I = -18\text{ mA}$			-1.2	V
I_I		$V_{CC} = 5.5\text{ V}$,	$V_I = 5.5\text{ V}$ or GND			±5	μA
I_{CC}		$V_{CC} = 5.5\text{ V}$,	$I_O = 0$, $V_I = V_{CC}$ or GND			50	μA
$\Delta I_{CC}‡$	Control inputs	$V_{CC} = 5.5\text{ V}$,	One input at 3.4 V, Other inputs at V_{CC} or GND			3.5	mA
C_i	Control inputs	$V_I = 3\text{ V}$ or 0				3	pF
$C_{io(OFF)}$		$V_O = 3\text{ V}$ or 0,	$\overline{OE} = V_{CC}$			6	pF
$r_{on}§$		$V_{CC} = 4.5\text{ V}$	$V_I = 0$	$I_I = 64\text{ mA}$	5	7	Ω
				$I_I = 30\text{ mA}$	5	7	
			$V_I = 2.4\text{ V}$,	$I_I = 15\text{ mA}$	10	15	

† All typical values are at $V_{CC} = 5\text{ V}$, $T_A = 25^\circ\text{C}$.

‡ This is the increase in supply current for each input that is at the specified TTL voltage level rather than V_{CC} or GND.

§ Measured by the voltage drop between the A and the B terminals at the indicated current through the switch. On-state resistance is determined by the lowest voltage of the two (A or B) terminals.

switching characteristics over recommended operating free-air temperature range, $C_L = 50\text{ pF}$ (unless otherwise noted) (see Figure 1)

PARAMETER	FROM (INPUT)	TO (OUTPUT)	MIN	MAX	UNIT
$t_{pd}¶$	A or B	B or A		0.25	ns
t_{en}	\overline{OE}	A or B	1	8.9	ns
t_{dis}	\overline{OE}	A or B	1	7.4	ns

¶ This propagation delay is the calculated RC time constant of the typical on-state resistance of the switch and the specified load capacitance, when driven by an ideal voltage source (zero output impedance).

SN74CBT3244 OCTAL FET BUS SWITCH

SCDS001J – NOVEMBER 1992 – REVISED OCTOBER 2000

PARAMETER MEASUREMENT INFORMATION

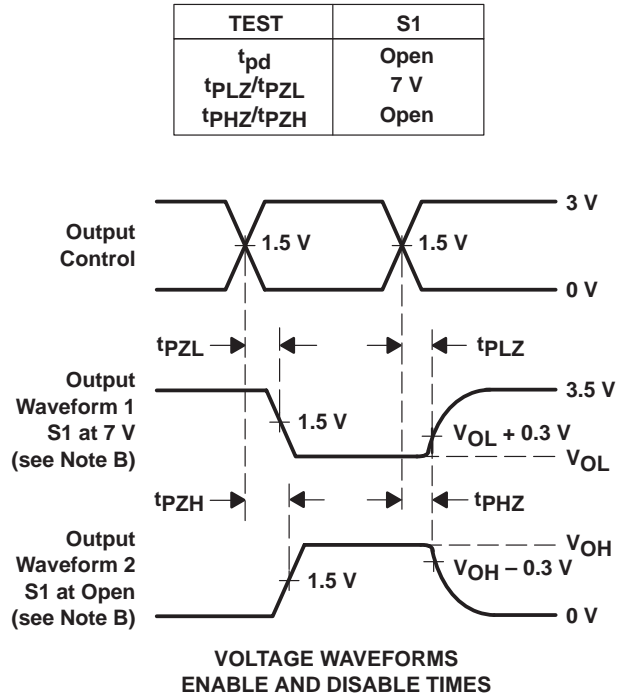
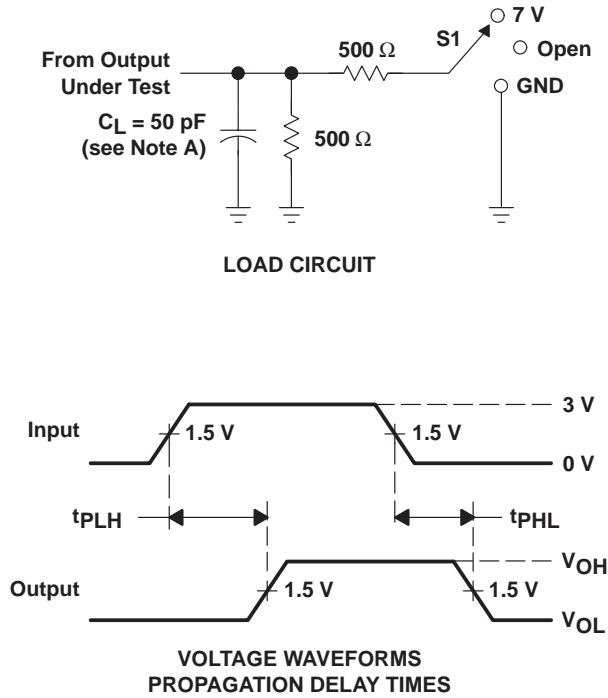

- NOTES:
- A. C_L includes probe and jig capacitance.
 - B. Waveform 1 is for an output with internal conditions such that the output is low except when disabled by the output control. Waveform 2 is for an output with internal conditions such that the output is high except when disabled by the output control.
 - C. All input pulses are supplied by generators having the following characteristics: PRR ≤ 10 MHz, Z_O = 50 Ω, t_r ≤ 2.5 ns, t_f ≤ 2.5 ns.
 - D. The outputs are measured one at a time with one transition per measurement.
 - E. t_{PLZ} and t_{PHZ} are the same as t_{dis}.
 - F. t_{PZL} and t_{PZH} are the same as t_{en}.
 - G. t_{PLH} and t_{PHL} are the same as t_{pd}.

Figure 1. Load Circuit and Voltage Waveforms

IMPORTANT NOTICE

Texas Instruments and its subsidiaries (TI) reserve the right to make changes to their products or to discontinue any product or service without notice, and advise customers to obtain the latest version of relevant information to verify, before placing orders, that information being relied on is current and complete. All products are sold subject to the terms and conditions of sale supplied at the time of order acknowledgment, including those pertaining to warranty, patent infringement, and limitation of liability.

TI warrants performance of its semiconductor products to the specifications applicable at the time of sale in accordance with TI's standard warranty. Testing and other quality control techniques are utilized to the extent TI deems necessary to support this warranty. Specific testing of all parameters of each device is not necessarily performed, except those mandated by government requirements.

Customers are responsible for their applications using TI components.

In order to minimize risks associated with the customer's applications, adequate design and operating safeguards must be provided by the customer to minimize inherent or procedural hazards.

TI assumes no liability for applications assistance or customer product design. TI does not warrant or represent that any license, either express or implied, is granted under any patent right, copyright, mask work right, or other intellectual property right of TI covering or relating to any combination, machine, or process in which such semiconductor products or services might be or are used. TI's publication of information regarding any third party's products or services does not constitute TI's approval, warranty or endorsement thereof.