

SN54ALS244A, SN54AS244, SN74ALS244A, SN74AS244 OCTAL BUFFERS AND LINE DRIVERS WITH 3-STATE OUTPUTS

D2661, DECEMBER 1982—REVISED MAY 1986

- 3-State Outputs Drive Bus Lines or Buffer Memory Address Registers
- P-N-P Inputs Reduce DC Loading
- Package Options Include Plastic "Small Outline" Packages, Ceramic Chip Carriers, and Standard Plastic and Ceramic 300-mil DIPs
- Dependable Texas Instruments Quality and Reliability

description

These octal buffers and line drivers are designed specifically to improve both the performance and density of three-state memory address drivers, clock drivers, and bus-oriented receivers and transmitters. Taken together with the 'ALS240A, 'ALS241A, 'AS240, and 'AS241, these devices provide the choice of selected combinations of inverting outputs, symmetrical \overline{G} (active-low output control) inputs, and complementary G and \overline{G} inputs.

The -1 version of the SN74ALS244A is identical to the standard version except that the recommended maximum I_{OL} is increased to 48 milliamperes. There is no -1 version of the SN54ALS244A.

The SN54ALS244A and SN54AS244 are characterized for operation over the full military temperature range of -55°C to 125°C. The SN74ALS244A and SN74AS244 are characterized for operation from 0°C to 70°C.

logic diagram (positive logic)

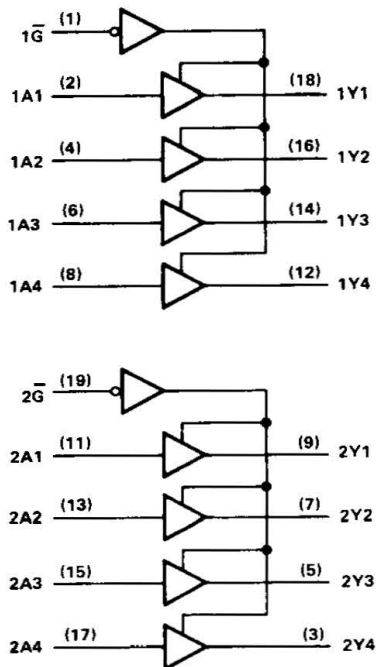

SN54ALS244A, SN54AS244 . . . J PACKAGE
SN74ALS244A, SN74AS244 . . . DW OR N PACKAGE
(TOP VIEW)

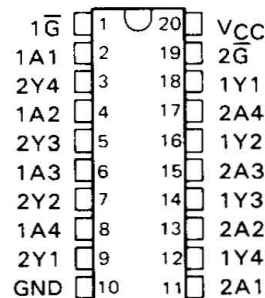

SN54ALS244A, SN54AS244 . . . FK PACKAGE
(TOP VIEW)

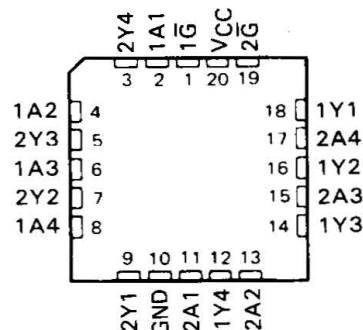

logic symbol†

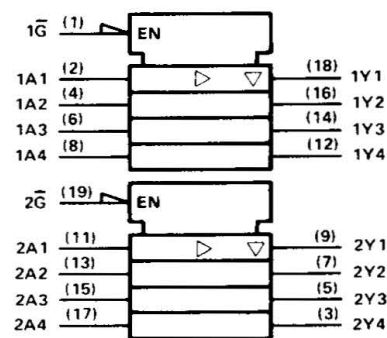

† This symbol is in accordance with ANSI/IEEE Std 91-1984 and IEC Publication 617-12. Pin numbers shown are for DW, J, and N packages.

PRODUCTION DATA documents contain information current as of publication date. Products conform to specifications per the terms of Texas Instruments standard warranty. Production processing does not necessarily include testing of all parameters.

TEXAS
INSTRUMENTS
POST OFFICE BOX 655012 • DALLAS, TEXAS 75265

Copyright © 1982, Texas Instruments Incorporated

SN54ALS244A, SN74ALS244A OCTAL BUFFERS AND LINE DRIVERS WITH 3-STATE OUTPUTS

absolute maximum ratings over operating free-air temperature range (unless otherwise noted)

Supply voltage, V_{CC}	7 V
Input voltage	7 V
Voltage applied to a disabled 3-state output	5.5 V
Operating free-air temperature range: SN54ALS244A	-55°C to 125°C
SN74ALS244A	0°C to 70°C
Storage temperature range	-65°C to 150°C

recommended operating conditions

		SN54ALS244A			SN74ALS244A			UNIT
		MIN	NOM	MAX	MIN	NOM	MAX	
V_{CC}	Supply voltage	4.5	5	5.5	4.5	5	5.5	V
V_{IH}	High-level input voltage	2			2			V
V_{IL}	Low-level input voltage			0.7			0.8	V
I_{OH}	High-level output current			-12			-15	mA
I_{OL}	Low-level output current			12			24	mA
							48 [†]	
T_A	Operating free-air temperature	-55		125	0		70	°C

[†]The extended limits apply only if V_{CC} is maintained between 4.75 V and 5.25 V.
The 48-mA limit applies for the SN74ALS244A-1 only.

electrical characteristics over recommended operating free-air temperature range (unless otherwise noted)

PARAMETER	TEST CONDITIONS	SN54ALS244A			SN74ALS244A			UNIT
		MIN	TYP [‡]	MAX	MIN	TYP [‡]	MAX	
V_{IK}	$V_{CC} = 4.5$ V, $I_I = -18$ mA			-1.5			-1.5	V
V_{OH}	$V_{CC} = 4.5$ V to 5.5 V, $I_{OH} = -0.4$ mA	$V_{CC}-2$			$V_{CC}-2$			V
	$V_{CC} = 4.5$ V, $I_{OH} = -3$ mA	2.4	3.2		2.4	3.2		
	$V_{CC} = 4.5$ V, $I_{OH} = -12$ mA	2						
	$V_{CC} = 4.5$ V, $I_{OH} = -15$ mA				2			
V_{OL}	$V_{CC} = 4.5$ V, $I_{OL} = 12$ mA		0.25	0.4		0.25	0.4	V
	$V_{CC} = 4.5$ V, $I_{OL} = 24$ mA					0.35	0.5	
	($I_{OL} = 48$ mA for -1 version)							
I_{OZH}	$V_{CC} = 5.5$ V, $V_O = 2.7$ V			20			20	μ A
I_{OZL}	$V_{CC} = 5.5$ V, $V_O = 0.4$ V			-20			-20	μ A
I_I	$V_{CC} = 5.5$ V, $V_I = 7$ V			0.1			0.1	mA
I_{IH}	$V_{CC} = 5.5$ V, $V_I = 2.7$ V			20			20	μ A
I_{IL}	$V_{CC} = 5.5$ V, $V_I = 0.4$ V			-0.1			-0.1	mA
I_{O5}	$V_{CC} = 5.5$ V, $V_O = 2.25$ V	-30		-112	-30		-112	mA
I_{CC}	$V_{CC} = 5.5$ V	Outputs high	9	15	9	15	mA	
		Outputs low	15	24	15	24		
		Outputs disabled	17	27	17	27		

[‡]All typical values are at $V_{CC} = 5$ V, $T_A = 25^\circ$ C.

⁵The output conditions have been chosen to produce a current that closely approximates one half of the true short-circuit output current, I_{OS} .

2

ALS and AS Circuits

SN54ALS244A, SN74ALS244A
OCTAL BUFFERS AND LINE DRIVERS WITH 3-STATE OUTPUTS

switching characteristics (see Note 1)

PARAMETER	FROM (INPUT)	TO (OUTPUT)	$V_{CC} = 4.5 \text{ V to } 5.5 \text{ V,}$ $C_L = 50 \text{ pF,}$ $R_1 = 500 \Omega,$ $R_2 = 500 \Omega,$ $T_A = \text{MIN to MAX}$				UNIT
			SN54ALS244A		SN74ALS244A		
			MIN	MAX	MIN	MAX	
t_{PLH}	A	Y	1	18	3	10	ns
t_{PHL}			3	13	3	10	
t_{PZH}	\bar{G}	Y	1	29	7	20	ns
t_{PZL}			1	27	7	20	
t_{PHZ}	\bar{G}	Y	2	12	2	10	ns
t_{PLZ}			1	21	3	13	

NOTE 1: Load circuit and voltage waveforms are shown in Section 1.

SN54AS244, SN74AS244

OCTAL BUFFERS AND LINE DRIVERS WITH 3-STATE OUTPUTS

absolute maximum ratings over operating free-air temperature range (unless otherwise noted)

Supply voltage, V_{CC}	7 V
Input voltage	7 V
Voltage applied to a disabled 3-state output	5.5 V
Operating free-air temperature range: SN54AS244	-55 °C to 125 °C
SN74AS244	0 °C to 70 °C
Storage temperature range	-65 °C to 150 °C

2

ALS and AS Circuits

recommended operating conditions

		SN54AS244			SN74AS244			UNIT
		MIN	NOM	MAX	MIN	NOM	MAX	
V_{CC}	Supply voltage	4.5	5	5.5	4.5	5	5.5	V
V_{IH}	High-level input voltage	2			2			V
V_{IL}	Low-level input voltage			0.8			0.8	V
I_{OH}	High-level output current			-12			-15	mA
I_{OL}	Low-level output current			48			64	mA
T_A	Operating free-air temperature	-55		125	0		70	°C

electrical characteristics over recommended operating free-air temperature range (unless otherwise noted)

PARAMETER	TEST CONDITIONS	SN54AS244			SN74AS244			UNIT	
		MIN	TYP [†]	MAX	MIN	TYP [†]	MAX		
V_{IK}	$V_{CC} = 4.5 V, I_I = -18 mA$			-1.2			-1.2	V	
V_{OH}	$V_{CC} = 4.5 V \text{ to } 5.5 V, I_{OH} = -2 mA$	$V_{CC} - 2$			$V_{CC} - 2$			V	
	$V_{CC} = 4.5 V, I_{OH} = -3 mA$	2.4	3.4		2.4	3.4			
	$V_{CC} = 4.5 V, I_{OH} = -12 mA$	2.4							
	$V_{CC} = 4.5 V, I_{OH} = -15 mA$				2.4				
V_{OL}	$V_{CC} = 4.5 V, I_{OL} = 48 mA$			0.55				V	
	$V_{CC} = 4.5 V, I_{OL} = 64 mA$						0.55		
I_{OZH}	$V_{CC} = 5.5 V, V_O = 2.7 V$			50			50	μA	
I_{OZL}	$V_{CC} = 5.5 V, V_O = 0.4 V$			-50			-50	μA	
I_I	$V_{CC} = 5.5 V, V_I = 7 V$			0.1			0.1	mA	
I_{IH}	$V_{CC} = 5.5 V, V_I = 2.7 V$			20			20	μA	
I_{IL}	\bar{G} A	$V_{CC} = 5.5 V, V_I = 0.4 V$			-0.5			-0.5	mA
					-1			-1	
$I_{O\ddagger}$	$V_{CC} = 5.5 V, V_O = 2.25 V$	-50		-150	-50		-150	mA	
I_{CC}	$V_{CC} = 5.5 V$	Outputs high	22	34	22	34		mA	
		Outputs low	60	90	60	90			
		Outputs disabled	34	54	34	54			

[†]All typical values are at $V_{CC} = 5 V, T_A = 25 °C$.

[‡]The output conditions have been chosen to produce a current that closely approximates one half of the true short-circuit output current, I_{OS} .

SN54AS244, SN74AS244
OCTAL BUFFERS AND LINE DRIVERS WITH 3-STATE OUTPUTS

switching characteristics (see Note 1)

PARAMETER	FROM (INPUT)	TO (OUTPUT)	$V_{CC} = 4.5 \text{ V to } 5.5 \text{ V,}$ $C_L = 50 \text{ pF,}$ $R_1 = 500 \Omega,$ $R_2 = 500 \Omega,$ $T_A = \text{MIN to MAX}$				UNIT
			SN54AS244		SN74AS244		
			MIN	MAX	MIN	MAX	
t_{PLH}	A	Y	2	9	2	6.2	ns
t_{PHL}			2	7	2	6.2	
t_{PZH}	\bar{G}	Y	2	10	2	9	ns
t_{PZL}			2	8	2	7.5	
t_{PHZ}	\bar{G}	Y	2	6.5	2	6	ns
t_{PLZ}			2	10.5	2	9	

NOTE 1: Load circuit and voltage waveforms are shown in Section 1.