

018213

SN54ALS131, SN54AS131A, SN74ALS131, SN74AS131A

3-LINE TO 8-LINE DECODERS/DEMULTIPLEXERS WITH ADDRESS REGISTERS

D2661, APRIL 1982—REVISED MAY 1986

- Combines Decoder and 3-Bit Address Register
- Incorporates 2 Enable Inputs to Simplify Cascading
- Package Options Include Plastic "Small Outline" Packages, Ceramic Chip Carriers, and Standard Plastic and Ceramic 300-mil DIPs
- Dependable Texas Instruments Quality and Reliability

SN54ALS131, SN54AS131A . . . J PACKAGE
SN74ALS131, SN74AS131A . . . D OR N PACKAGE
(TOP VIEW)

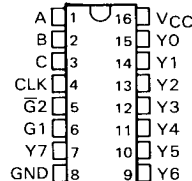

SN54ALS131, SN54AS131A . . . FK PACKAGE
(TOP VIEW)

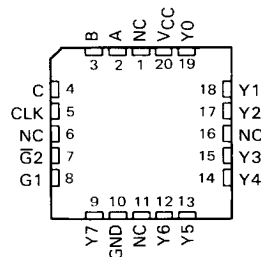

NC—No internal connection

description

The 'ALS131 and 'AS131A are three-line to eight-line decoder/demultiplexer with registers on the three address inputs. When the clock input (CLK) goes from low to high, the 'ALS131 and 'AS131A act as decoders/demultiplexers and the address present at the select inputs (A, B, and C) is stored in the registers. Further address changes are ignored until the next rising transition of CLK. The output enable controls, G1 and $\overline{G2}$, control the state of the outputs independently of the select or CLK inputs. All of the outputs are high unless G1 is high and $\overline{G2}$ is low. The 'ALS131 and 'ALS131A are ideally suited for implementing glitch-free decoders in strobed (stored-address) applications in bus-oriented systems.

The SN54ALS131 and SN54AS131A are characterized for operation over the full military temperature range of -55°C to 125°C . The SN74ALS131 and SN74AS131A are characterized for operation from 0°C to 70°C .

logic symbols† (alternatives)

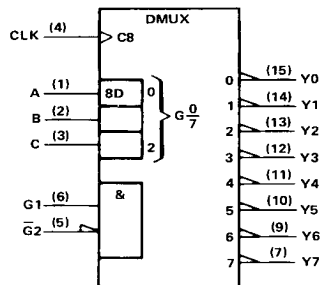
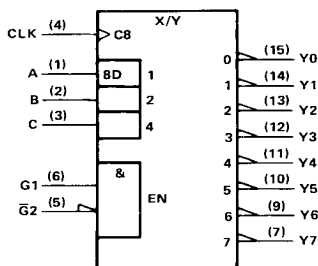

†These symbols are in accordance with ANSI/IEEE Std 91-1984 and IEC Publication 617-12. Pin numbers shown are for D, J, and N packages.

PRODUCTION DATA documents contain information current as of publication date. Products conform to specifications per the terms of Texas Instruments standard warranty. Production processing does not necessarily include testing of all parameters.



POST OFFICE BOX 655012 • DALLAS, TEXAS 75265

Copyright © 1982, Texas Instruments Incorporated

SN54ALS131, SN54AS131A, SN74ALS131, SN74AS131A
3-LINE TO 8-LINE DECODERS/DEMULTIPLEXERS WITH ADDRESS REGISTERS

logic diagram (positive logic)

2
ALS and AS Circuits

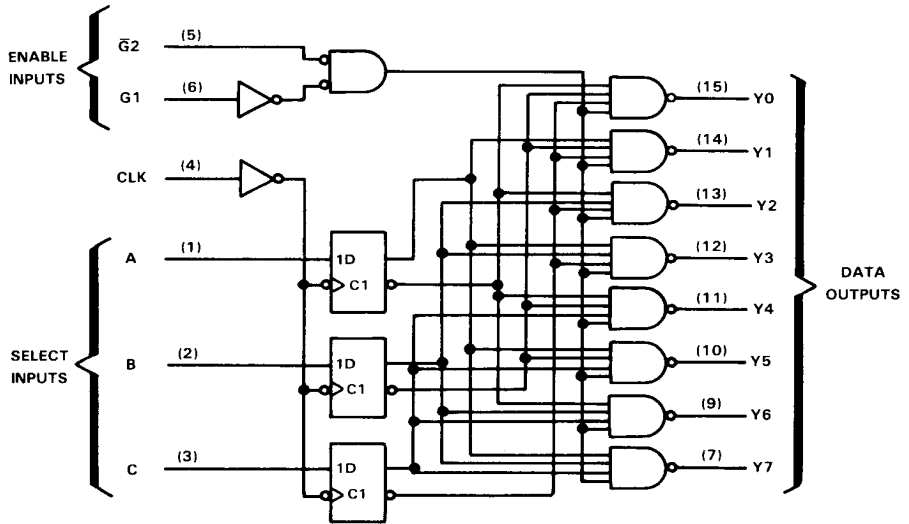

Pin numbers shown are for D, J, and N packages.

FUNCTION TABLE

CLK	ENABLE		SELECT			OUTPUTS								
	G1	G2	C	B	A	Y0	Y1	Y2	Y3	Y4	Y5	Y6	Y7	
X	X	H	X	X	X	H	H	H	H	H	H	H	H	H
X	L	X	X	X	X	H	H	H	H	H	H	H	H	H
↑	H	L	L	L	L	L	H	H	H	H	H	H	H	H
↑	H	L	L	L	H	H	L	H	H	H	H	H	H	H
↑	H	L	L	H	H	H	H	H	L	H	H	H	H	H
↑	H	L	H	L	L	H	H	H	H	L	H	H	H	H
↑	H	L	H	L	H	H	H	H	H	H	L	H	H	H
↑	H	L	H	H	L	H	H	H	H	H	H	L	H	H
↑	H	L	H	H	H	H	H	H	H	H	H	H	L	L
L or H	H	L	X	X	X	OUTPUTS CORRESPONDING TO STORED ADDRESS, L; ALL OTHERS, H								

absolute maximum ratings over operating free-air temperature range (unless otherwise noted)

Supply voltage, VCC	7 V
Input voltage	7 V
Operating free-air temperature range: SN54ALS131, SN54AS131A	-55°C to 125°C
SN74ALS131, SN74AS131A	0°C to 70°C
Storage temperature	-65°C to 150°C

SN54ALS131, SN74ALS131 3-LINE TO 8-LINE DECODERS/DEMULTIPLEXERS WITH ADDRESS REGISTERS

recommended operating conditions

		SN54ALS131			SN74ALS131			UNIT		
		MIN	NOM	MAX	MIN	NOM	MAX			
V _{CC}	Supply voltage	4.5	5	5.5	4.5	5	5.5	V		
V _{IH}	High-level input voltage	2			2			V		
V _{IL}	Low-level input voltage				0.8			V		
I _{OH}	High-level output current				-0.4			mA		
I _{OL}	Low-level output current				8			mA		
f _{clock}	Clock frequency	0			50			MHz		
t _w	Pulse duration	CLK high		12.5			10		ns	
		CLK low		12.5			10			
t _{su}	Setup time at A, B, and C before CLK ↑	15			10			ns		
t _h	Hold time at A, B, and C after CLK ↑	0			0			ns		
T _A	Operating free-air temperature	-55			125			0	70	°C

electrical characteristics over recommended operating free-air temperature range (unless otherwise noted)

PARAMETER	TEST CONDITIONS	SN54ALS131			SN74ALS131			UNIT
		MIN	TYP†	MAX	MIN	TYP†	MAX	
V _{IK}	V _{CC} = 4.5 V, I _I = -18 mA	-1.5			-1.5			V
V _{OH}	V _{CC} = 4.5 V to 5.5 V, I _{OH} = -0.4 mA	V _{CC} -2			V _{CC} -2			V
V _{OL}	V _{CC} = 4.5 V, I _{OL} = 4 mA	0.25			0.4			V
	V _{CC} = 4.5 V, I _{OL} = 8 mA				0.35			
I _I	V _{CC} = 5.5 V, V _I = 7 V				0.1			mA
I _{IH}	V _{CC} = 5.5 V, V _I = 2.7 V				20			μA
I _{IL}	V _{CC} = 5.5 V, V _I = 0.4 V				-0.1			mA
I _O ‡	V _{CC} = 5.5 V, V _O = 2.25 V	-30			-112			mA
I _{CC}	V _{CC} = 5.5 V	5			11			mA

†All typical values are at V_{CC} = 5 V, T_A = 25°C.

‡The output conditions have been chosen to produce a current that closely approximates one half of the true short-circuit output current, I_{OS}.

switching characteristics (see Note 1)

PARAMETER	FROM (INPUT)	TO (OUTPUT)	V _{CC} = 4.5 V to 5.5 V, C _L = 50 pF, R _L = 500 Ω, T _A = MIN to MAX				UNIT
			SN54ALS131		SN74ALS131		
			MIN	MAX	MIN	MAX	
f _{max}			40		50	MHz	
t _{PLH}	CLK	Y	8	28	8	25	ns
t _{PHL}			7	24	7	20	
t _{PLH}	G1	Y	7	24	7	20	ns
t _{PHL}			6	20	6	17	
t _{PLH}	G2	Y	5	18	5	15	ns
t _{PHL}			5	18	5	15	

NOTE 1: Load circuit and voltage waveforms are shown in Section 1.

SN54AS131A, SN74AS131A

3-LINE TO 8-LINE DECODERS/DEMULTIPLEXERS WITH ADDRESS REGISTERS

recommended operating conditions

		SN54AS131A			SN74AS131A			UNIT
		MIN	NOM	MAX	MIN	NOM	MAX	
V _{CC}	Supply voltage	4.5	5	5.5	4.5	5	5.5	V
V _{IH}	High-level input voltage	2			2			V
V _{IL}	Low-level input voltage				0.8			V
I _{OH}	High-level output current				-2			mA
I _{OL}	Low-level output current				20			mA
f _{clock}	Clock frequency	0			90			MHz
t _w	Pulse duration	CLK high		5.5		5		ns
		CLK low		5.5		5		
t _{su}	Setup time at A, B, and C before CLK↑	3.5			3.5			ns
t _h	Hold time at A, B, and C after CLK↑	1			0			ns
T _A	Operating free-air temperature	-55			125			°C

2

ALS and AS Circuits

electrical characteristics over recommended operating free-air temperature range (unless otherwise noted)

PARAMETER	TEST CONDITIONS	SN54AS131A		SN74AS131A		UNIT
		MIN	TYP†	MAX	MIN	
V _{IK}	V _{CC} = 4.5 V, I _I = -18 mA			-1.2		V
V _{OH}	V _{CC} = 4.5 V to 5.5 V, I _{OH} = -2 mA	V _{CC} - 2		V _{CC} - 2		V
V _{OL}	V _{CC} = 4.5 V, I _{OL} = 20 mA	0.35		0.5		V
I _I	V _{CC} = 5.5 V, V _I = 7 V			0.1		mA
I _{IH}	V _{CC} = 5.5 V, V _I = 2.7 V			20		μA
I _{IL}	V _{CC} = 5.5 V, V _I = 0.4 V			-0.5		mA
I _O ‡	V _{CC} = 5.5 V, V _O = 2.25 V	-30		-112		mA
I _{CCH}	V _{CC} = 5.5 V	15		29		mA
I _{CCL}	V _{CC} = 5.5 V	16		30		mA

†All typical values are at V_{CC} = 5 V, T_A = 25°C.

‡The output conditions have been chosen to produce a current that closely approximates one half of the true short-circuit output current, I_{OS}.

switching characteristics (see Note 1)

PARAMETER	FROM (INPUT)	TO (OUTPUT)	V _{CC} = 4.5 V to 5.5 V, C _L = 50 pF, R _L = 500 Ω, T _A = MIN to MAX				UNIT
			SN54AS131A		SN74AS131A		
			MIN	MAX	MIN	MAX	
f _{max}			90		100	MHz	
t _{PLH}	CLK	Y	2	15	2	3, 5, 14.5	ns
t _{PHL}			2	10	2	9.5	
t _{PLH}	G1	Y	2	10.5	2	10	ns
t _{PHL}			2	9	2	9	
t _{PLH}	G2	Y	2	7.5	2	7	ns
t _{PHL}			2	8.5	2	8.5	

NOTE 1: Load circuit and voltage waveforms are shown in Section 1.