

SIEMENS

Microcomputer Components

Standalone Full-CAN Controller

SAE 81C90/91

Stand Alone Full CAN Controller

SAE 81C90/91

- Full CAN controller for data rate up to 1 Mbaud
- Complies with CAN specification V2.0 part A (part B passive)
- Up to 16 messages simultaneous (each with maximum data length)
- Message identifier reprogrammable "on the fly"
- Several transmit jobs can be sent with a single command
- Transmit check
- Basic CAN feature
- Time stamp for eight messages
- Two host interfaces (parallel and serial)
- User-configurable outputs for different bus concepts
- Programmable clock output
- Two 8 bit I/O-Port extension (P-LCC-44-1 package only)

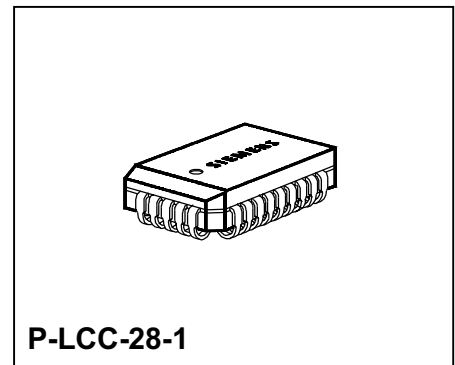
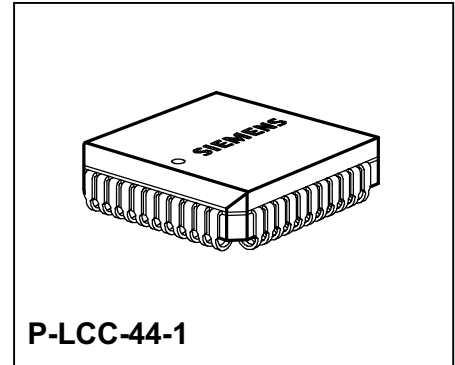

The device comes in two versions:

SAE 81C90 in a P-LCC-44-1 package with two 8-bit I/O ports, and

SAE 81C91 in a P-LCC-28-1 package without I/O ports.

SAE 81C90/91	
Revision History: Version 01.97	
Previous Releases:	06.95 05.94 (Copy version)
Page	Subjects
1056	Figure 1 corrected.
1057	Figure 2 corrected.
1059	Notes updated.
1065 - 1084	Register description and arrangement improved.
1066, 1069	New register maps.
1093	t_{AVLL} , t_{LLAX} , t_{DVWH} changed to 10 ns.
1093	t_{WHDX} changed to 5 ns.

Controller Area Network (CAN): License of Robert Bosch GmbH

Introduction

The Siemens Stand Alone Full CAN (SFCAN) circuit incorporates all the parts for completely autonomous transmission and reception of messages using the CAN protocol. The flexible, programmable interface allows hookup to different implementations of the physical layer. The link to a host controller can be made either by a multiplexed 8-bit address/data bus or by a high-speed, serial synchronous interface.

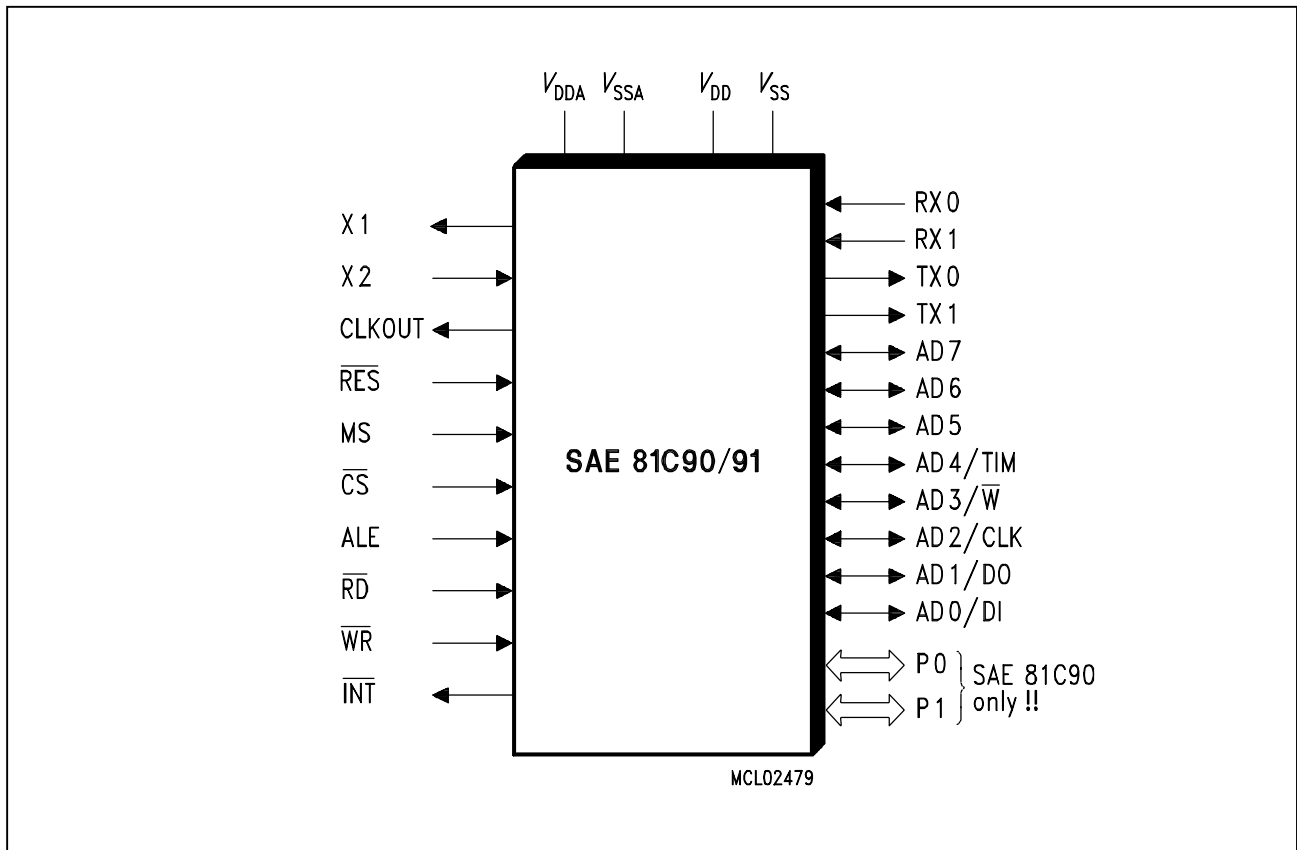

Figure 1
Logic Symbol

Ordering Information

Type	Ordering Code	Package	Function
SAE 81C91	Q67121-F0001	P-LCC-28-1	Stand Alone Full CAN Controller Temperature range - 40 to + 110 °C
SAE 81C90	Q67121-H9038	P-LCC-44-1	Stand Alone Full CAN Controller Temperature range - 40 to + 110 °C

Pin Configurations
(top view)

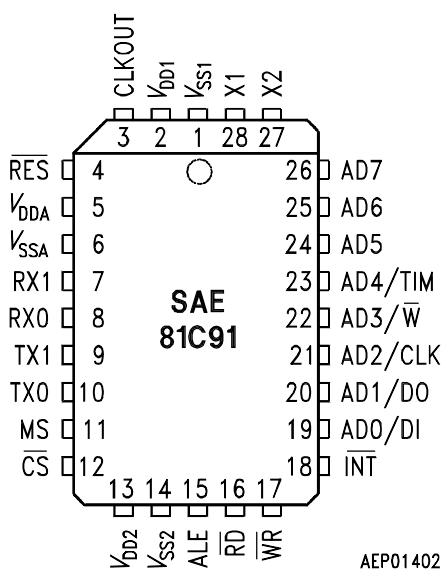
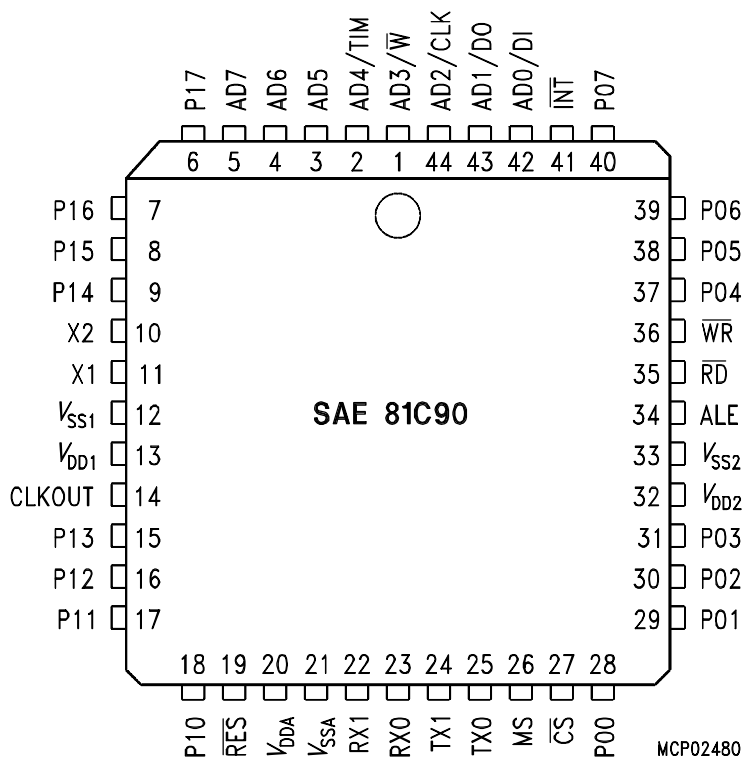

Figure 2

Pin Definitions and Functions

Symbol	Pin Number		Input (I) Output (O)	Function
	PLCC-48	PLCC-28		
X1 ¹⁾	11	28	O	Crystal oscillator output. Must be unconnected for external clock input.
X2 ¹⁾	10	27	I	Crystal oscillator input. Used for external clock input.
CLKOUT ¹⁾	14	3	O	Clock output
$\overline{\text{RES}}$	19	4	I	Reset. (Schmitt trigger characteristic)
AD0/DI	42	19	I/O	PI: Address / Data bus / SI: Data input
AD1/DO	43	20	I/O	PI: Address / Data bus / SI: Data output
AD2/CLK	44	21	I/O	PI: Address / Data bus / SI: Clock input
AD3/ $\overline{\text{W}}$	1	22	I/O	PI: Address / Data bus / SI: Write select
AD4/TIM	2	23	I/O	PI: Address / Data bus / SI: TIM = 0: Timing A; TIM = 1: Timing B
AD5	3	24	I/O	PI: Address/Data bus
AD6	4	25	I/O	PI: Address/Data bus
AD7	5	26	I/O	PI: Address/Data bus
$\overline{\text{RD}}$	35	16	I	PI: Read / SI: no Function
$\overline{\text{WR}}$	36	17	I	PI: Write / SI: no Function
ALE	34	15	I	PI: Address Latch Enable / SI: no Function
$\overline{\text{CS}}$	27	12	I	Chip Select
$\overline{\text{INT}}$	41	18	O	Interrupt
MS	26	11	I	Mode Select (PI ↔ SI)
P00 ... P03, P04 ... P07	28, 29, 30, 31, 37, 38, 39, 40	–	I/O	Port 0 These pins provide internal pullup resistors of about 10...200 kΩ.
P10 ... P13, P14 ... P17	18, 17, 16, 15, 9, 8, 7, 6	–	I/O	Port 1 These pins provide internal pullup resistors of about 10...200 kΩ.
TX0	25	10	O	Transmitter output 0
TX1	24	9	O	Transmitter output 1
RX0	23	8	I	Comparator input 0 / Digital input ²⁾
RX1	22	7	I	Comparator input 1 ²⁾
V_{DDA}	20	5	I	Analog power supply for comparator (may be unconnected using the digital mode)

Pin Definitions and Functions (cont'd)

Symbol	Pin Number		Input (I) Output (O)	Function
	PLCC-48	PLCC-28		
V_{SSA}	21	6	I	Analog power ground for comparator (must always be connected)
V_{DD1}	13	2	I	Digital power supply ³⁾
V_{DD2}	32	13	I	Digital power supply
V_{SS1}	12	1	I	Digital power ground ³⁾
V_{SS2}	33	14	I	Digital power ground

- 1) For best results keep the crystal circuitry connections as short as possible and keep the CLKOUT line away from it.
- 2) If the bus lines work according to the ISO specification, additional circuitry is necessary for interconnection of the input comparator to the bus lines.
The digital mode is enabled by setting bit DI in register BL2. When using the digital mode pin RX1 should be on V_{SS} .
- 3) It is recommended to decouple these supply pins close to the device using a 10 pF capacitor in addition to the standard 100 nF capacitor.

Functional Description

The Siemens stand-alone Full-CAN (SFCAN) circuit is a large-scale-integrated peripheral device that executes the entire protocol of an automobile or industrial network.

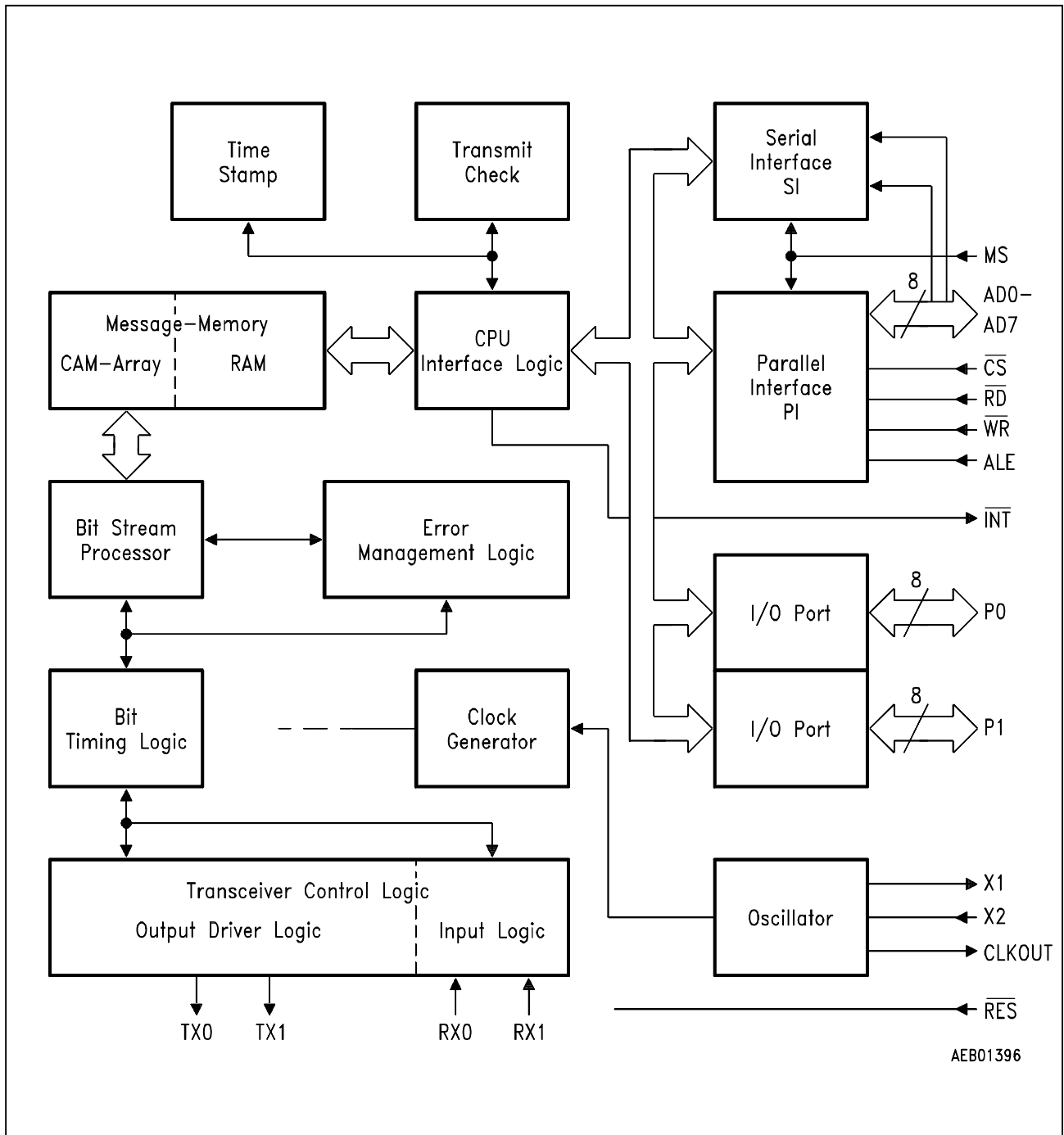

Figure 3
Block Diagram

Bus communication is based on the controller-area-network (CAN) protocol. With features like short message length, guaranteed reaction time for messages of appropriate priority, which is defined by the message identifiers. Also included are powerful error detection and treatment capabilities plus ease of operation. The CAN protocol is especially designed for the requirements of automobile and industrial electronic networks.

The SFCAN circuit incorporates all the parts for completely independent transmission and reception of messages using the CAN protocol. The flexible, programmable interface allows connection to different implementations of the physical layer. The link to a host controller can be made either by a multiplexed 8-bit address/data bus or by a high-speed, serial synchronous interface.

Message Memory

The SFCAN circuit filters incoming messages with an associative memory (CAM = content-addressable memory). For this the identifier and RTR bits of the required message must be written to the appropriate memory location.

The identifier of each incoming message is compared with the identifiers stored in the CAM. Upon a match the received data bytes are written into the RAM buffer of the matching message. At the same time the corresponding receive-ready bit is set and a receive interrupt is generated, if it is enabled. If no match is detected, the received message is rejected.

Identifiers can be reprogrammed at any time, although it is possible that data of the old or new identifier may be lost during reprogramming.

An incoming transmit request will only be satisfied automatically by the hardware if the RTR bit of the particular identifier is set in CAM.

To ensure data consistency when reading or writing several data bytes of a specific message the message objects are not accessed directly but via a 64-bit shadow register (see figure below).

This shadow register stores the complete data field of a certain message object for both reading and writing.

For read accesses the message's data field is copied to the shadow register...

...with the 1st read access to the respective data field (e.g. 80_H ... 87_H for message 0), or

...with any read access to byte 7 of the respective data field (e.g. 87_H for message 0).

This ensures that all bytes read via the shadow register belong to the same message, even though a new one might have been received in the meantime.

For write accesses the shadow register is copied to the respective message data field...

...with any write access to byte 0 of the respective data field (e.g. 80_H for message 0).

This ensures that only completely updated message are transmitted.

It is therefore recommended to begin all read and write accesses with the most-significant data byte of a message and end with data byte 0. This ensures operations on consistent data and correct transfers between the shadow register and the message RAM.

Note: For these reasons it is absolutely essential to ensure that the writing of data is not interrupted by a read operation and vice versa, a read operation should not be interrupted by a write.

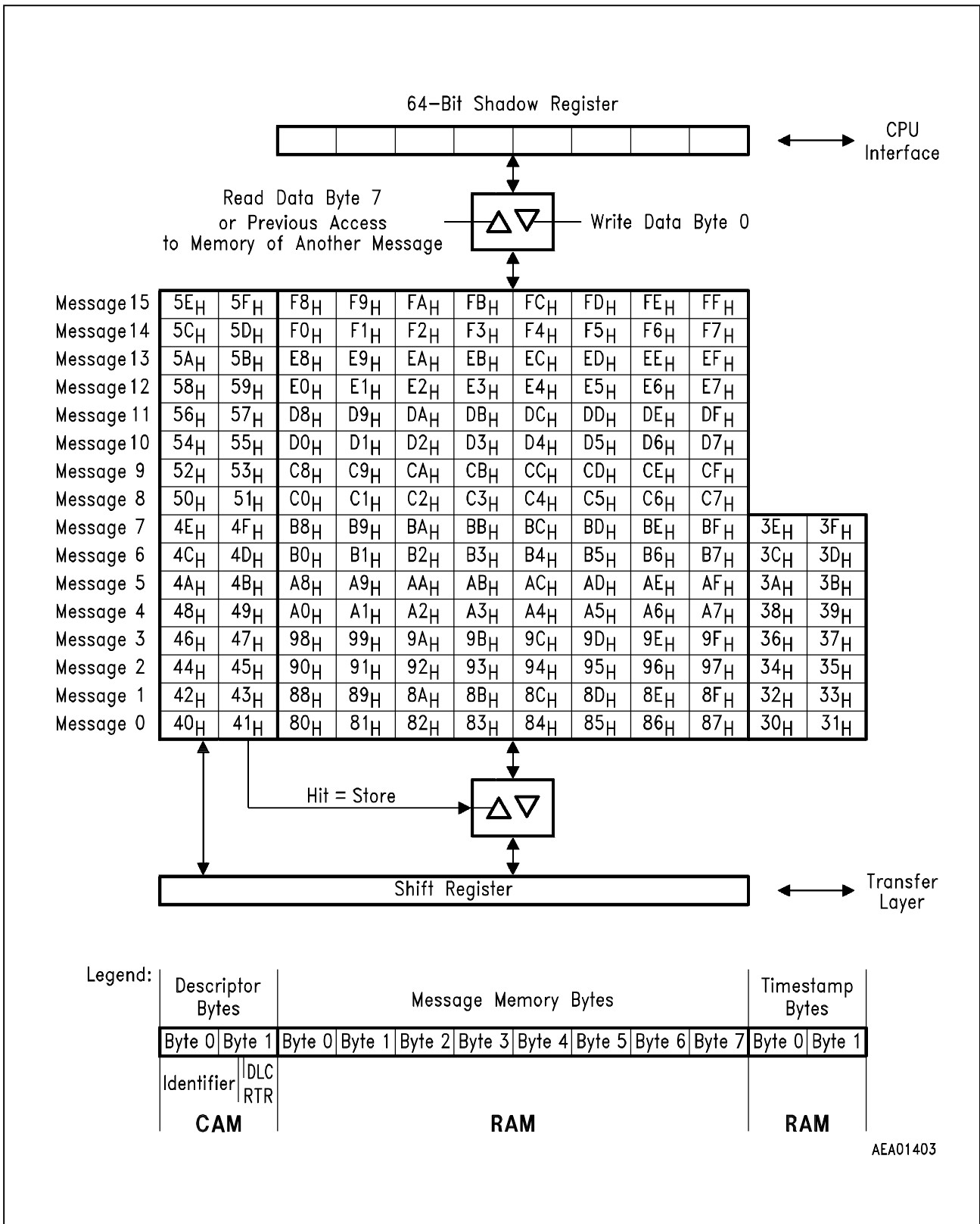

Figure 4
CAM, Message Memory and Time-Stamp Registers

Bit Stream Processor (BSP)

The bit-stream processor controls the entire protocol, differentiates between the frames types and detects frame errors.

Error Management Logic (EML)

The error-management logic receives error messages from the BSP and, in turn, sends back information about error state to the BSP and CIL.

Bit Timing Logic (BTL)

The bit-timing logic determines the timing of the bits and synchronizes with the edges of the bit stream on the CAN bus.

Transceiver Control Logic (TCL)

The transceiver-control logic consists of programmable output driver, input comparator and input multiplexer.

Clock Generator (CG)

The clock generator consists of an oscillator and a programmable divider. The oscillator can be fed from an external quartz crystal, ceramic resonator or an external timing source. The permissible crystal frequency is 1 to 20 MHz, and the external clock may be between 0 and 20 MHz. A programmable frequency, dependent on the crystal clock, is available with the CLKOUT pin, e.g. for the clocking of a host controller.

CPU Interface Logic (CIL)

The CPU interface logic controls the access of the host via the parallel or serial interface, interprets the commands and outputs status and interrupt information.

Transmit Check

The CAN protocol ensures a very high integrity for the data transferred over the bus. The on-chip path from the data stored in parallel to the serial bit stream is not protected by the protocol. To eliminate any possible uncertainties at this point too, the SFCAN circuit incorporates a transmit-check unit. This unit reads back a transmitted message via the normal receive path from the bus interface and compares the data with those written into the message memory by the host controller. If any inconsistency of the data is detected, the current message will be invalidated by an error frame.

The transmit-check error counter TCEC is then incremented by 1. If this counter reaches 4 an error interrupt (bit TCI in the INT register) is generated, provided that this has not been masked (bit ETCL in the IMSK register). This count will also produce the Bus Off status.

The TCEC is set to 0 after a reset and can be read and also written for test purposes at any time.

Note: The transmit-check is an additional feature of the Siemens Full CAN Chip and is not part of the CAN protocol.

Time Stamp

It is impossible to determine from the received data in the message memory when they were received. So the host controller is unable to derive any information about the actuality or the repetition rate of the data.

To enable an indication of the time of reception for at least some of the messages, a 16-bit timer is implemented on the SAE 81C90/91. The content of this gets written into the time-stamp registers of the particular message when it is received (for the messages 0 through 7). There are two time-stamp bytes for each of the messages 0 through 7, and these hold the value of the 16-bit timer.

The actuality of a message is determined by subtracting the old time-stamp of a message, stored in the host controller, from the new one, with respect to the timer overflow bit.

Overflow of the timer can be detected by bit TSOV in the CTRL register. This bit does not trigger an interrupt and has to be reset by the host controller. Depending on the setting of bitfield TSP in register CTRL, the counter is fed with 1/32, 1/64, 1/128 or 1/256 of the bus clock. The momentary timer status can be read and set at any time. The timer starts at 0 after a reset and cannot be stopped.

I/O-Ports

There are two parallel I/O ports in the SAE 81C90, each with eight pins. These ports are configured pin by pin as input or output, depending on the contents of the port-direction register.

The output data for the port pins can be written (latched) into the port-latch register. Reading this register reproduces the contents of the latch. The levels on the port pins can be read from the port-pin register.

For the SAE 81C91 in its P-LCC-28-1 package, the pads of the I/O ports are not bonded and therefore unavailable to the user.

Note: Registers PxPDR and PxPL may be used for general purpose storage if the ports are not used.

Device Control and Registers

The operation of the SAE 81C90/91 is controlled via a number of registers. These registers allow initialization and function control, provide status information and configure the message objects. The upper part of the address space provides access to the data buffers of the message objects. The data buffers are ordered sequentially as shown in the table below.

The register map on the next page summarizes the other registers (i.e. except the data registers) ordered by their address, while the following pages describe these registers in more detail from a functional point of view.

Note: Locations marked “*Reserved*” in the register map must not be written in initialization mode. This also applies to locations 60_H through 7F_H.

Data Registers

Address	Function	
80 _H	Byte 0	Message 0
81 _H	Byte 1	
82 _H	Byte 2	
83 _H	Byte 3	
84 _H	Byte 4	
85 _H	Byte 5	
86 _H	Byte 6	
87 _H	Byte 7	
88 _H	Byte 0	Message 1
89 _H	Byte 1	
:	:	:
F6 _H	Byte 6	Message 14
F7 _H	Byte 7	
F8 _H	Byte 0	Message 15
F9 _H	Byte 1	
FA _H	Byte 2	
FB _H	Byte 3	
FC _H	Byte 4	
FD _H	Byte 5	
FE _H	Byte 6	
FF _H	Byte 7	

Register Map (ordered by address)

Addr.	Reg. Name	Reset	Addr.	Reg. Name	Reset	Addr.	Reg. Name	Reset
00 _H	BL1	00 _H	20 _H	<i>Reserved</i>	---	40 _H	DR0H	UU _H
01 _H	BL2	00 _H	21 _H	<i>Reserved</i>	---	41 _H	DR0L	UU _H
02 _H	OC	00 _H	22 _H	<i>Reserved</i>	---	42 _H	DR1H	UU _H
03 _H	BRP	00 _H	23 _H	<i>Reserved</i>	---	43 _H	DR1L	UU _H
04 _H	RRR1	00 _H	24 _H	<i>Reserved</i>	---	44 _H	DR2H	UU _H
05 _H	RRR2	00 _H	25 _H	<i>Reserved</i>	---	45 _H	DR2L	UU _H
06 _H	RIMR1	00 _H	26 _H	<i>Reserved</i>	---	46 _H	DR3H	UU _H
07 _H	RIMR2	00 _H	27 _H	<i>Reserved</i>	---	47 _H	DR3L	UU _H
08 _H	TRS1	00 _H	28 _H	P0PDR	00 _H	48 _H	DR4H	UU _H
09 _H	TRS2	00 _H	29 _H	P0PR	XX _H	49 _H	DR4L	UU _H
0A _H	IMSK	00 _H	2A _H	P0LR	00 _H	4A _H	DR5H	UU _H
0B _H	<i>Reserved</i>	---	2B _H	<i>Reserved</i>	---	4B _H	DR5L	UU _H
0C _H	<i>Reserved</i>	---	2C _H	P1PDR	00 _H	4C _H	DR6H	UU _H
0D _H	<i>Reserved</i>	---	2D _H	P1PR	XX _H	4D _H	DR6L	UU _H
0E _H	<i>Reserved</i>	---	2E _H	P1LR	00 _H	4E _H	DR7H	UU _H
0F _H	<i>Reserved</i>	---	2F _H	<i>Reserved</i>	---	4F _H	DR7L	UU _H
10 _H	MOD	00 _H	30 _H	TSR0H	UU _H	50 _H	DR8H	UU _H
11 _H	INT	00 _H	31 _H	TSR0L	UU _H	51 _H	DR8L	UU _H
12 _H	CTRL	00 _H	32 _H	TSR1H	UU _H	52 _H	DR9H	UU _H
13 _H	<i>Reserved</i>	---	33 _H	TSR1L	UU _H	53 _H	DR9L	UU _H
14 _H	CC	01 _H	34 _H	TSR2H	UU _H	54 _H	DR10H	UU _H
15 _H	TCEC	00 _H	35 _H	TSR2L	UU _H	55 _H	DR10L	UU _H
16 _H	TCD	XX _H	36 _H	TSR3H	UU _H	56 _H	DR11H	UU _H
17 _H	<i>Reserved</i>	---	37 _H	TSR3L	UU _H	57 _H	DR11L	UU _H
18 _H	TRR1	00 _H	38 _H	TSR4H	UU _H	58 _H	DR12H	UU _H
19 _H	TRR2	00 _H	39 _H	TSR4L	UU _H	59 _H	DR12L	UU _H
1A _H	RRP1	00 _H	3A _H	TSR5H	UU _H	5A _H	DR13H	UU _H
1B _H	RRP2	00 _H	3B _H	TSR5L	UU _H	5B _H	DR13L	UU _H
1C _H	TSCH	00 _H	3C _H	TSR6H	UU _H	5C _H	DR14H	UU _H
1D _H	TSCL	00 _H	3D _H	TSR6L	UU _H	5D _H	DR14L	UU _H
1E _H	<i>Reserved</i>	---	3E _H	TSR7H	UU _H	5E _H	DR15H	UU _H
1F _H	<i>Reserved</i>	---	3F _H	TSR7L	UU _H	5F _H	DR15L	UU _H

Note: The locations marked “UU_H” are not changed upon a reset.
After a power on reset they are undefined (XX_H), of course.

Descriptor Registers

A descriptor register is available for each message object and contains the eleven bits of the message identifier (ID.0 through ID.10), the remote-transmission-request bit (RTR) and the data length code (DLC) of a message.

DRnH	7	6	5	4	3	2	1	0
Address: XX _H	ID.10	ID.9	ID.8	ID.7	ID.6	ID.5	ID.4	ID.3
Reset Value: UU _H	rw	rw	rw	rw	rw	rw	rw	rw

DRnL	7	6	5	4	3	2	1	0
Address: XX _H	ID.2	ID.1	ID.0	RTR	DLC			
Reset Value: UU _H	rw	rw	rw	rw	rw	rw	rw	rw

Bit(field)	Function
DLC	Data Length Code Defines the number of data bytes of message n. Defined values are 0000...1000, i.e. 0...8 bytes. Other values are not permitted.
RTR	Remote Transmission Request Bit '0': This message operates as a data frame. '1': This message operates as a remote frame. Note: See description and table below.
ID.10-0	Identifier Identifier associated with message n, controls the acceptance of received frames and is inserted into transmitted frames.

n = 0...15

Bit RTR determines the function of the corresponding message object when it is transmitted, and its reaction on a received data frame or remote frame.

The table below summarizes the message object's behaviour in the different cases.

RTR bit	Object is transmitted	Matching Data Frame received	Matching Remote Frame received
'0' (data frame)	The message object is transmitted as a standard data frame.	The data frame is stored in the message object.	The remote frame is ignored.
'1' (remote frame)	The message object is transmitted as a remote frame (i.e. a request).	The data frame is ignored and not stored.	The message object is sent as a data frame.

Note: For the transmission of remote frames (RTR = 1) the data-length-code should be set to '0'.

Descriptor Register Arrangement

Address	Function	
40 _H	High Byte	Descriptor Register for Message Object 0
41 _H	Low Byte	
42 _H	High Byte	Descriptor Register for Message Object 1
43 _H	Low Byte	
:	:	:
5C _H	High Byte	Descriptor Register for Message Object 14
5D _H	Low Byte	
5E _H	High Byte	Descriptor Register for Message Object 15
5F _H	Low Byte	

Control Register Summary

Register Name	Address	Function	Reset Value	Read Write ¹⁾
OC	02 _H	Output-control register	00 _H	r/w, I
CC	14 _H	Clock-control register	01 _H	wo
CTRL	12 _H	Control register	00 _H	r/w
MOD	10 _H	Mode/status register	00 _H	r/w
INT	11 _H	Interrupt register	00 _H	r/w
IMSK	0A _H	Interrupt-mask register	00 _H	r/w
BL1	00 _H	Bit-length register 1	00 _H	r/w, I
BL2	01 _H	Bit-length register 2	00 _H	r/w, I
BRP	03 _H	Baud-rate prescaler	00 _H	wo, I
RRR1	04 _H	Receive-ready register 1	00 _H	r/w
RRR2	05 _H	Receive-ready register 2	00 _H	r/w
RIMR1	06 _H	Receive-interrupt-mask register 1	00 _H	r/w
RIMR2	07 _H	Receive-interrupt-mask register 2	00 _H	r/w
TRSR1	08 _H	Transmit-request-set register 1	00 _H	r/w
TRSR2	09 _H	Transmit-request-set register 2	00 _H	r/w
TRRR1	18 _H	Transmit-request-reset register 1	00 _H	wo
TRRR2	19 _H	Transmit-request-reset register 2	00 _H	wo
RRPR1	1A _H	Remote-request-pending register 1	00 _H	ro
RRPR2	1B _H	Remote-request-pending register 2	00 _H	ro
TSCH	1C _H	Time-Stamp counter high byte	00 _H	r/w
TSCL	1D _H	Time-Stamp counter low byte	00 _H	r/w
TCEC	15 _H	Transmit-check error counter	00 _H	r/w
TCD	16 _H	Transmit-check data register	XX	ro
P0PDR	28 _H	Port 0 port-direction register	00 _H	r/w
P1PDR	2C _H	Port 1 port-direction register	00 _H	r/w
P0LR	2A _H	Port 0 latch register	00 _H	r/w
P1LR	2E _H	Port 1 latch register	00 _H	r/w
P0PR	29 _H	Port 0 pin register	XX _H	ro
P1PR	2D _H	Port 1 pin register	XX _H	ro

Note: ¹⁾ **ro:** read only, **r/w:** read and write access, **wo:** write only, **I:** access only with bit IM set.

Output-Control Register

The output drivers of the SAE 81C90/91's transmit pins (TXn) can be individually configured. Thus they can be adapted to the requirements of the external bs system.

OC	7	6	5	4	3	2	1	0
Address: 02 _H	OCTP1	OCTN1	OCP1	OCTP0	OCTN0	OCP0	OCM	
Reset Value: 00 _H	rw	rw	rw	rw	rw	rw	rw	rw

Bit(field)	Function
OCM	Output Mode '0X': Normal Mode: TX0 = Bit Sequence, TX1 = Bit Sequence. '10': Test Mode: TX0 = Bit Sequence, TX1 = RX0. '11': Clock Mode: TX0 = Bit Sequence, TX1 = Bit Clock.
OCPn	Output Polarity '0': Output is driven directly with CAN data. '1': Output is driven with inverted CAN data.
OCTNn	Negative Output Transistor Control '0': The low side output transistor TnN is disabled. '1': The low side output transistor TnN drives the pin according to data.
OCTPn	Positive Output Transistor Control '0': The high side output transistor TnP is disabled. '1': The high side output transistor TnP drives the pin according to data.

n = 0, 1

Note: This register can only be written when bit IM (MOD.0) is set.

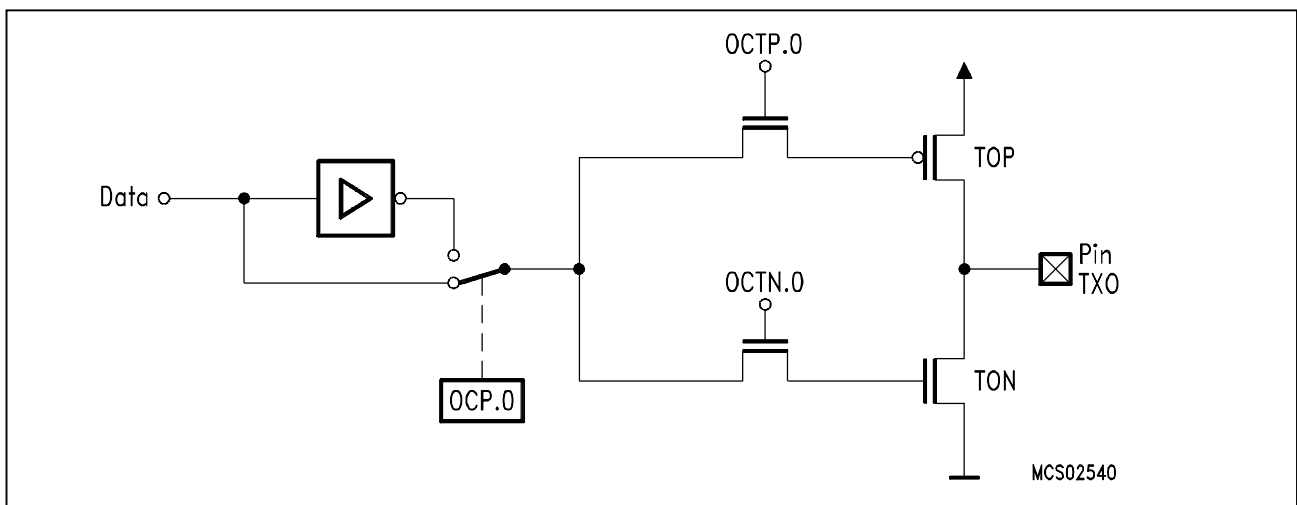

Figure 5
Output Control Circuitry

Output Programming

OCTP.n	OCTN.n	OCP.n	Data	TnP	TnN	TXn-Level
0	0	0	0 = dominant	OFF	OFF	float
0	0	0	1 = recessive	OFF	OFF	float
0	0	1	0	OFF	OFF	float
0	0	1	1	OFF	OFF	float
0	1	0	0	OFF	ON	LOW
0	1	0	1	OFF	OFF	float
0	1	1	0	OFF	OFF	float
0	1	1	1	OFF	ON	LOW
1	0	0	0	OFF	OFF	float
1	0	0	1	ON	OFF	HIGH
1	0	1	0	ON	OFF	HIGH
1	0	1	1	OFF	OFF	float
1	1	0	0	OFF	ON	LOW
1	1	0	1	ON	OFF	HIGH
1	1	1	0	ON	OFF	HIGH
1	1	1	1	OFF	ON	LOW

TnP is the output transistor switching to V_{DD} , TnN switches to V_{SS} .
 TXn is the output level at the transmit pin.

Clock Control Register

The Clock Control Register determines the output frequency at pin CLKOUT which is derived from the oscillator frequency.

CCR	7	6	5	4	3	2	1	0
Address: 14 _H	-	-	-	-	CC			
Reset Value: 01 _H	-	-	-	-	W	W	W	W

Bit(field)	Function
CC	<p>Clock Output Control</p> <p>'0000': $f_{CLKOUT} = f_{OSC}$</p> <p>'0001': $f_{CLKOUT} = f_{OSC} / 2$</p> <p>'0010': $f_{CLKOUT} = f_{OSC} / 4$</p> <p>'0011': $f_{CLKOUT} = f_{OSC} / 6$</p> <p>'0100': $f_{CLKOUT} = f_{OSC} / 8$</p> <p>'0101': $f_{CLKOUT} = f_{OSC} / 10$</p> <p>'0110': $f_{CLKOUT} = f_{OSC} / 12$</p> <p>'0111': $f_{CLKOUT} = f_{OSC} / 14$</p> <p>'1XXX': $f_{CLKOUT} = \text{LOW}$ (clock output is switched off)</p>

The Clock Control Register requires a special protocol for writing in order to prevent the clock output from being changed inadvertently:

- Step 1: Write 80_H to CC
- Step 2: Write desired value to CC (bits 7...4 must be '0000')

Note: Not defined bit positions must be '0' for write accesses.

Control Register

CTRL	7	6	5	4	3	2	1	0
Address: 12 _H	RX	TST	TSP		TSOV	SME	TCE	MM
Reset Value: 00 _H	rw	rw	rw	rw	rw	rw	rw	rw

Bit(field)	Function
MM	<p>Monitor Mode</p> <p>'0': Message object 0 operates like all other objects.</p> <p>'1': Message object 0 receives all identifiers that are not accepted by other objects (corresponds to a Basic CAN receive register).</p>
TCE	<p>Transmit Check Enable</p> <p>'0': If the transmit check detects an error, there is no intervention.</p> <p>'1': If the transmit check detects an error, the message is invalidated by an error frame and the error counter TCEC is incremented by 1. If the counter reaches 4, the Bus Off status is initiated and, if enabled, an interrupt (TCI) is generated.</p>
SME	<p>Sleep Mode Enable</p> <p>'0': Normal operation.</p> <p>'1': The sleep mode is enabled: the crystal oscillator is deactivated, all other activities are inhibited.</p> <p>The wake up is done by a reset signal or by an active signal at the \overline{CS} pin or by an input edge going from recessive to dominant at pin Rx0 or Rx1.</p>
TSOV	<p>Time Stamp Overflow</p> <p>'0': There has been no overflow</p> <p>'1': There was at least one overflow of the time-stamp timer.</p>
TSP	<p>Time Stamp Prescaler (Defines the input clock of the time-stamp timer)</p> <p>'00': $f_{BL} / 32$</p> <p>'01': $f_{BL} / 64$</p> <p>'10': $f_{BL} / 128$</p> <p>'11': $f_{BL} / 256$ (For f_{BL} see baud-rate prescaler BRP).</p>
TST	<p>Time Stamp Test</p> <p>'0': The prescaler is activated.</p> <p>'1': The time-stamp prescaler is deactivated.</p> <p>(Only for testing purposes, bit IM = MOD.0 must be set to '1').</p>
RX	<p>Input Monitor RX</p> <p>This bit monitors the actual state of the digital input pin RX0.</p>

Mode/Status-Register

MOD	7	6	5	4	3	2	1	0
Address: 10 _H	ADE	RS	TC	TWL	RWL	BS	RES	IM
Reset Value: 00 _H	rw	r	r	r	r	r	rw	rw

Bit(field)	Function
IM	<p>Init Mode</p> <p>'0': Normal mode.</p> <p>'1': Initialization mode: write access to the configuration registers BL1, BL2, OC, BRP is enabled. If the bit stays set, the chip enters the normal mode, with enabled access to the configuration registers. If this bit is set in conjunction with bit RES a hard software reset is activated.</p>
RES	<p>Reset Request</p> <p>'0': Normal mode.</p> <p>'1': The chip enters the reset state: – if bit IM = '0' a soft software reset takes place. – if bit IM = '1' a hard software reset takes place. Further details see below.</p>
BS	<p>Bus State (read only)</p> <p>'0': Normal mode.</p> <p>'1': Bus Off state, the IC does not participate in bus activities.</p>
RWL	<p>Receiver Warning Level (read only)</p> <p>'0': Receive-error counter below 96.</p> <p>'1': Receive-error counter equal or above 96.</p>
TWL	<p>Transmit Warning Level (read only)</p> <p>'0': Transmit-error counter below 96.</p> <p>'1': Transmit-error counter equal or above 96.</p>
TC	<p>Transmission Complete (read only)</p> <p>'0': The last transmission request is not yet executed successfully.</p> <p>'1': The last transmission request was executed successfully.</p>
RS	<p>Receive State (read only)</p> <p>'0': No reception active.</p> <p>'1': Currently the SAE 81C90/91 is in receive mode.</p>
ADE	<p>Auto Decrement Enable</p> <p>'0': No automatic address decrement.</p> <p>'1': With every read or write access using the serial synchronous interface SI the address is automatically decremented by one. So data can be accessed sequentially without the need of writing a new address.</p>

Notes on Bit TC

Scanning this bit is particularly useful if only one transmission is active. If there are several transmission jobs at the same time, it is better to scan the transmit-request register, because bit TC may possibly only be set very briefly between acknowledgment of the previous message and the start of the next one.

Notes on Bit RES and IM and reset modes

There are three different reset modes implemented in the SAE 81C90/91:

hardware reset (activated by low level on pin $\overline{\text{RES}}$)

hard software reset (activated by setting both bits RES and IM to 1)

soft software reset (activated by setting bit RES to 1 and bit IM to 0)

The only difference between hardware and hard software reset affect bits RES and IM, that are not changed by software reset.

With soft software reset the registers RRR1, RRR2, TRSR1, TRSR2, RRPR1 and RRPR2 are cleared, all bus activities are stopped, the error counters are not cleared, the Bus Off state is cancelled only after 128 idle phases (according to the CAN protocol 1 idle phase = 11 recessive bits in sequence). Simply spoken a soft software reset interrupts and cancels all bus activities and - if necessary - recovers from Bus Off state.

Notes on Bit RS

Bit RS directly reflects the internal status.

RS is '0' during transmission or when the SAE 81C90/91 is idle.

RS is '1' during reception or during the synchronization after a reset.

Interrupt Register

INT	7	6	5	4	3	2	1	0
Address: 11 _H	TCI	EPI	BOI	WUPI	RFI	WLI	TI	RI
Reset Value: 00 _H	rw	rw	rw	rw	rw	rw	rw	rw

Bit(field)	Function
RI	Receive Interrupt After a valid message has been received and filed, this bit is set and an interrupt generated. This bit will remain set until all bits of the registers RRR1 and RRR2 are reset.
TI	Transmit Interrupt This bit is set and an interrupt generated as soon as a transmit request has been processed.
WLI	Warning Level Interrupt If at least one of the two error counters is greater than or equals 96, this bit is set and an interrupt generated.
RFI	Remote Frame Interrupt This interrupt is generated after reception of a remote frame.
WUPI	Wake Up Interrupt After a wake-up this bit is set and an interrupt generated.
BOI	Bus Off Interrupt This bit is set and an interrupt generated when the Bus Off status is entered.
EPI	Error Passive Interrupt If at least one of the two error counters is greater than or equals 128, this bit is set and an interrupt generated.
TCI	Transmit Check Interrupt If the transmit-check error counter reaches 4, this bit is set and an interrupt generated.

Note: All bits of this register must be reset by software. This is done by writing '0' to the respective bit location, writing '1' has no effect.

An interrupt is only generated if the respective IMSK bit is set. The bits in this register are set independent of register IMSK (see below).

The interrupt output is active for at least one bit time. The interrupt output is deactivated when all enabled request bits are cleared. A request bit is enabled by setting its corresponding mask bit. Masked request bits do not activate the interrupt output.

Interrupt-Mask Register

These mask bits determine if an event activates the INT pin. They do not influence the INT register.

IMSK	7	6	5	4	3	2	1	0
Address: 0A _H	ETCI	EEPI	EBOI	EWUPI	ERFI	EWLI	ETI	ERI
Reset Value: 00 _H	rw	rw	rw	rw	rw	rw	rw	rw

Bit(field)	Function
ERI	Enable Receive Interrupt '0': No receive interrupt enabled. '1': Receive interrupts are enabled.
ETI	Enable Transmit Interrupt '0': No transmit interrupt enabled. '1': Completed transmit jobs generate interrupts.
EWLI	Enable Warning Level Interrupt '0': No warning level interrupt enabled. '1': There is an interrupt when the warning level is reached.
ERFI	Enable Remote Frame Interrupt '0': No remote frame interrupt enabled. '1': A receive interrupt is generated after receiving a remote frame
EWUPI	Enable Wake Up Interrupt '0': No wake up interrupt enabled. '1': Wake-up interrupt is enabled.
EBOI	Enable Bus Off Interrupt '0': No bus off interrupt enabled. '1': Bus off interrupt is enabled.
EEPI	Enable Error Passive Interrupt '0': No error passive interrupt enabled. '1': Error passive interrupt is enabled.
ETCI	Enable Transmit Check Error Interrupt '0': No transmit check interrupt enabled. '1': Transmit-check error interrupt is enabled.

Bit-Length Registers

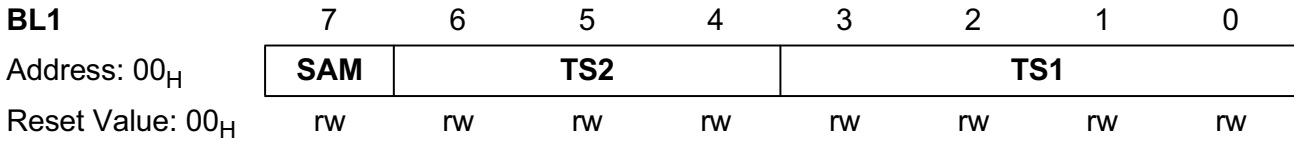

Bit(field)	Function
TS1	Length of Timing Segment 1 (TSeg1). $t_{\text{Tseg1}} = (\text{TS1} + 1) \times t_{\text{SCL}}$. For t_{SCL} see baud-rate prescaler BRP.
TS2	Length of Timing Segment 2 (TSeg2). $t_{\text{Tseg2}} = (\text{TS2} + 1) \times t_{\text{SCL}}$. For t_{SCL} see baud-rate prescaler BRP.
SAM	Sample Rate '0': Input signal is sampled once per bit. '1': Input signal is sampled three times per bit. Note: Bit SAM should only be set to '1' using very low baud rates.

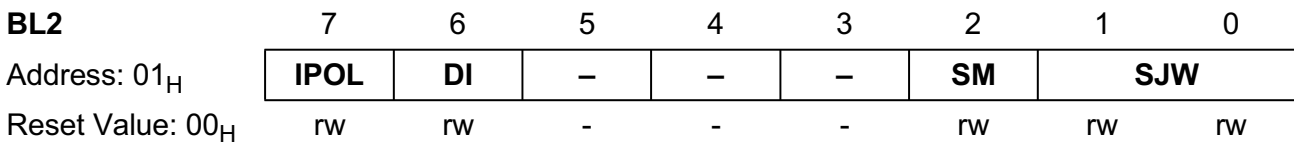

Bit(field)	Function
SJW	Maximum Synchronization Jump Width. $t_{\text{SJWwidth}} = (\text{SJW} + 1) \times t_{\text{SCL}}$. For t_{SCL} see baud-rate prescaler BRP.
SM	Speed Mode (Defines edge used for synchronization) '0': Recessive to dominant is used. '1': Both edges are used. Note: According to the CAN specification this bit should not be set to '1'.
DI	Digital Input '0': The input signal is applied to the input comparator. ¹⁾ '1': The input signal on pin RX0 is evaluated digitally. The input comparator is inactive. Pin RX1 should be on V_{SS} .
IPOL	Input Polarity '0': The input level remains unaltered. '1': The input level is inverted.

Note: Not defined bit positions must be '0' for write accesses.
 The Bit Length Registers BL1 and BL2 can only be written while bit IM (MOD.0) is set.
¹⁾ If the bus lines work according to the ISO specification, additional circuitry is necessary for interconnection of the input comparator to the bus lines.

Baud Rate Prescaler Register

The register is not readable and can only be written when bit IM (MOD.0) is set.

BRPR	7	6	5	4	3	2	1	0
Address: 03 _H	-	-	BRP					
Reset Value: 00 _H	-	-	W	W	W	W	W	W

Bit(field)	Function
BRP	<p>Baud Rate Prescaler This prescaler determines the period of the system clock: $t_{SCL} = (BRP + 1) \times 2 \times t_{OSC}$, where $t_{OSC} = 1 / f_{crystal}$.</p>

Note: Not defined bit positions must be '0' for write accesses.

The bit length t_{BL} is computed as follows:

$$t_{BL} = t_{TSeg1} + t_{TSeg2} + 1 t_{SCL}$$

The baudrate BR can be computed with the following formula:

$$BR = f_{crystal} / (2 \times (BRP + 1) \times (TS1 + TS2 + 3))$$

- Note:** BRP see Baud Rate Prescaler Register
 TS1 see Bit Length Register 1
 TS2 see Bit Length Register 1

Receive-Ready Registers

RRR2	7	6	5	4	3	2	1	0
Address: 05 _H	RR15	RR14	RR13	RR12	RR11	RR10	RR9	RR8
Reset Value: 00 _H	rw	rw	rw	rw	rw	rw	rw	rw

RRR1	7	6	5	4	3	2	1	0
Address: 04 _H	RR7	RR6	RR5	RR4	RR3	RR2	RR1	RR0
Reset Value: 00 _H	rw	rw	rw	rw	rw	rw	rw	rw

Bit(field)	Function
RRn	Receive Ready Bit '0': No new message received in object n. '1': A new message has been received and stored in object n.

These register bits can be reset by writing '0' to the respective bit, writing '1' has no effect. Bit RRn is set when a message has arrived and been written into the memory location of message n. Setting this bit by hardware can generate a receive interrupt, which can be blocked by bit RIMn in the receive-interrupt-mask register. Bits RRn must be reset by software.

Receive-Interrupt-Mask Registers

Setting bit RIMn enables a receive interrupt to be generated if the receive-ready bit RRn has been set, i.e. a message has arrived and was written into the memory location of message n.

RIMR2	7	6	5	4	3	2	1	0
Address: 07 _H	RIM15	RIM14	RIM13	RIM12	RIM11	RIM10	RIM9	RIM8
Reset Value: 00 _H	rw	rw	rw	rw	rw	rw	rw	rw

RIMR1	7	6	5	4	3	2	1	0
Address: 06 _H	RIM7	RIM6	RIM5	RIM4	RIM3	RIM2	RIM1	RIM0
Reset Value: 00 _H	rw	rw	rw	rw	rw	rw	rw	rw

Bit(field)	Function
RIMn	Receive Interrupt Mask Bit '0': No interrupt upon reception of object n. '1': When a new message is stored in object n an interrupt is generated.

Note: Bit ERI in the interrupt-mask register IM blocks all receive interrupts, even if bits RIMn are set.

Transmit Request Registers

The **Transmit Request Set Registers** provide a transmission request bit (TRS_n) for each message object. Setting a transmission request bit causes the respective message x to be transmitted. The bit is cleared by hardware after transmission. Several bits can be set simultaneously. In this way all messages whose request bits are set are transmitted in turn, starting with the memory location with the highest number.

Note: A transmission request bit is set by writing '1' to the respective bit location (TRS_n). Writing '0' has no effect.

TRSR2	7	6	5	4	3	2	1	0
Address: 09 _H	TRS15	TRS14	TRS13	TRS12	TRS11	TRS10	TRS9	TRS8
Reset Value: 00 _H	rw	rw	rw	rw	rw	rw	rw	rw

TRSR1	7	6	5	4	3	2	1	0
Address: 08 _H	TRS7	TRS6	TRS5	TRS4	TRS3	TRS2	TRS1	TRS0
Reset Value: 00 _H	rw	rw	rw	rw	rw	rw	rw	rw

Bit(field)	Function
TRS _n	<p>Transmit Request Set Bit</p> <p>'0': No change of the respective transmit request bit.</p> <p>'1': The respective transmit request bit is cleared.</p>

n = 0...15

The **Transmit Request Reset Registers** provide a transmit request reset bit (TRR_n) for each transmit request bit TRS_n, i.e. for each message object.

Writing '1' to a TRR_n bit clears the corresponding transmission request bit TRS_n. This causes a transmission request, initiated by the corresponding bit TRS_n, to be cancelled, provided that it is not currently processed.

This scheme avoids conflicts when writing to register bits while they are cleared by hardware because of a completed transmission.

Note: Registers TRRR_x cannot be read.

TRRR2

	7	6	5	4	3	2	1	0
Address: 19 _H	TRR15	TRR14	TRR13	TRR12	TRR11	TRR10	TRR9	TRR8
Reset Value: 00 _H	w	w	w	w	w	w	w	w

TRRR1

	7	6	5	4	3	2	1	0
Address: 18 _H	TRR7	TRR6	TRR5	TRR4	TRR3	TRR2	TRR1	TRR0
Reset Value: 00 _H	w	w	w	w	w	w	w	w

Bit(field)	Function
TRRx	Transmit Request Reset Bit '0': No change of the respective transmit request bit. '1': The respective transmit request bit is cleared.

Remote-Request-Pending Registers

RRPR2

	7	6	5	4	3	2	1	0
Address: 1B _H	RRP15	RRP14	RRP13	RRP12	RRP11	RRP10	RRP9	RRP8
Reset Value: 00 _H	r	r	r	r	r	r	r	r

RRPR1

	7	6	5	4	3	2	1	0
Address: 1A _H	RRP7	RRP6	RRP5	RRP4	RRP3	RRP2	RRP1	RRP0
Reset Value: 00 _H	r	r	r	r	r	r	r	r

Bit(field)	Function
RRPn	Remote Request Pending Bit '0': No remote request pending. '1': A remote request (remote frame) for message n was received but is not yet answered by the transmission of the corresponding data frame.

n = 0...15

Message Time Stamp

This mechanism stores the time at which a specific message was received, i.e. it assigns a time stamp to that message. For this purpose the contents of the free-running time stamp counter TSC is copied to the time stamp register TSRn of the respective message object upon reception of this message.

The **Time Stamp Counter Registers** provide access to the free-running time stamp counter.

TSCH	7	6	5	4	3	2	1	0
Address: 1C _H	TSC.15	TSC.14	TSC.13	TSC.12	TSC.11	TSC.10	TSC.9	TSC.8
Reset Value: 00 _H	rw	rw	rw	rw	rw	rw	rw	rw

TSCL	7	6	5	4	3	2	1	0
Address: 1D _H	TSC.7	TSC.6	TSC.5	TSC.4	TSC.3	TSC.2	TSC.1	TSC.0
Reset Value: 00 _H	rw	rw	rw	rw	rw	rw	rw	rw

Bit(field)	Function
TSC	Time Stamp Counter Current contents of the free running time stamp counter.

The **Time-Stamp Registers** are available for each of message objects 0...7 (see table below) and contain the time-stamp of the corresponding message. These registers can only be read.

TSRnH	7	6	5	4	3	2	1	0
Address: 3X _H	TSn.15	TSn.14	TSn.13	TSn.12	TSn.11	TSn.10	TSn.9	TSn.8
Reset Value: UU _H	r	r	r	r	r	r	r	r

TSRnL	7	6	5	4	3	2	1	0
Address: 3X _H	TSn.7	TSn.6	TSn.5	TSn.4	TSn.3	TSn.2	TSn.1	TSn.0
Reset Value: UU _H	r	r	r	r	r	r	r	r

Bit(field)	Function
TSn	Time Stamp n A 16-bit timer value to identify the time of reception of message n.

n = 0...7

Time Stamp Register Table

Address	Function	
30 _H	High Byte	Time-Stamp 0
31 _H	Low Byte	
32 _H	High Byte	Time-Stamp 1
33 _H	Low Byte	
:	:	:
3C _H	High Byte	Time-Stamp 6
3D _H	Low Byte	
3E _H	High Byte	Time-Stamp 7
3F _H	Low Byte	

Transmit Check Error Counter

TCEC	7	6	5	4	3	2	1	0
Address: 15 _H	-	-	-	-	-	TCECV		
Reset Value: 00 _H	-	-	-	-	-	rw	rw	rw

Bit(field)	Function
TCECV	Transmit Check Error Counter Value Number of errors detected by the transmit check unit. When a count of 4 is reached an interrupt is generated if enabled. If bit TCE (CTRL.1) is set to '1' the Bus Off status is entered in this case.

Note: Not defined bit positions must be '0' for write accesses.

Transmit Check Data Register

This register supports an error analysis when a transmit check error is encountered. Reading TCD provides the byte which was actually being sent when the error occurred.

TCD	7	6	5	4	3	2	1	0
Address: 16 _H	Data Byte							
Reset Value: XX _H	r	r	r	r	r	r	r	r

Bit(field)	Function
Data Byte	The data byte which was attempted to be sent while a transmit check error was encountered.

Port Control Registers

These registers control the parallel ports P0 and P1 which are provided in the SAE 81C90.

The **Port Direction Registers PxPDR** select each port pin separately for input (PxPDR.n='0') or output (PxPDR.n='1'). After reset the ports are switched as inputs.

P1PDR	7	6	5	4	3	2	1	0
Address: 2C _H	P1PD.7	P1PD.6	P1PD.5	P1PD.4	P1PD.3	P1PD.2	P1PD.1	P1PD.0
Reset Value: 00 _H	rw	rw	rw	rw	rw	rw	rw	rw

P0PDR	7	6	5	4	3	2	1	0
Address: 28 _H	P0PD.7	P0PD.6	P0PD.5	P0PD.4	P0PD.3	P0PD.2	P0PD.1	P0PD.0
Reset Value: 00 _H	rw	rw	rw	rw	rw	rw	rw	rw

The **Port Latch Registers PxLR** store the output data for those port pins that are switched to output.

P1LR	7	6	5	4	3	2	1	0
Address: 2E _H	P1L.7	P1L.6	P1L.5	P1L.4	P1L.3	P1L.2	P1L.1	P1L.0
Reset Value: 00 _H	rw	rw	rw	rw	rw	rw	rw	rw

P0LR	7	6	5	4	3	2	1	0
Address: 2A _H	P0L.7	P0L.6	P0L.5	P0L.4	P0L.3	P0L.2	P0L.1	P0L.0
Reset Value: 00 _H	rw	rw	rw	rw	rw	rw	rw	rw

The **Port Pin Registers PxPR** provide the current level of the port pins. These registers can only be read.

P1PR	7	6	5	4	3	2	1	0
Address: 2D _H	P1P.7	P1P.6	P1P.5	P1P.4	P1P.3	P1P.2	P1P.1	P1P.0
Reset Value: 00 _H	r	r	r	r	r	r	r	r

P0PR	7	6	5	4	3	2	1	0
Address: 29 _H	P0P.7	P0P.6	P0P.5	P0P.4	P0P.3	P0P.2	P0P.1	P0P.0
Reset Value: 00 _H	r	r	r	r	r	r	r	r

In parallel to the standard CMOS structure there are additional internal pullup devices of about 10...200 kΩ at each port pin.

Note: Registers PxPDR and PxPL may be used for general purpose storage if the ports are not used.

Bit Timing

A regular bit period is composed of the following three segments:

- synchronization segment
- timing segment 1
- timing segment 2.

The sampling point is between timing segment 1 and timing segment 2.

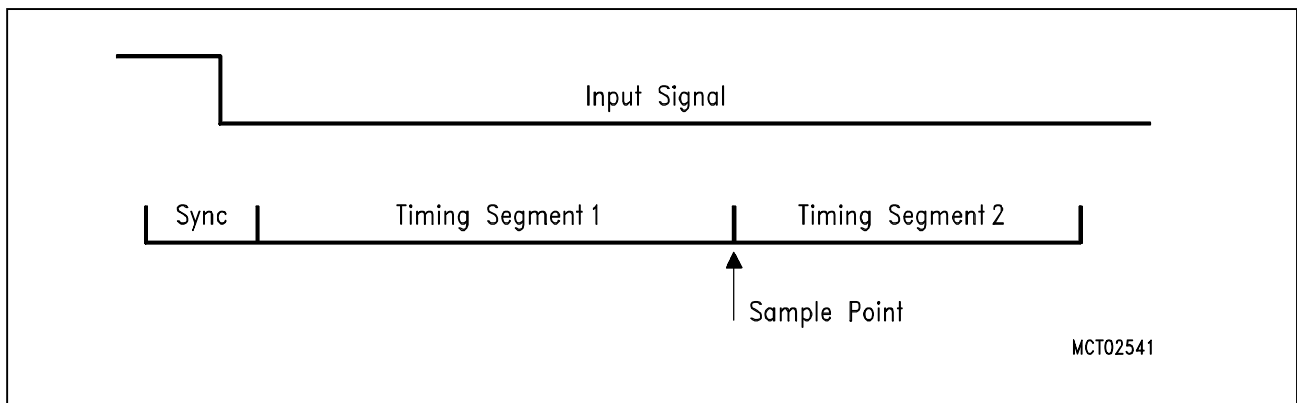

Figure 6
Bit Time Segments

Synchronization

The edge of the input signal is expected during the sync segment (duration = 1 system clock cycle = $1 t_{SCL}$).

Timing Segment 1 (TSeg1)

Timing segment 1 determines the sampling point within a bit period. This point is always at the end of segment 1. The segment is programmable from 1 to $16 t_{SCL}$ (see bit-length register BL1).

Timing Segment 2 (TSeg2)

Timing segment 2 provides extra time for internal processing after the sampling point. The segment is programmable from 1 to $8 t_{SCL}$ (see bit-length register BL1).

Synchronization Jump Width (SJW)

To compensate for phase shifts between the oscillator frequencies of the different bus stations, each CAN controller must be able to synchronize to the relevant signal edge of the incoming signal. The synchronization jump width (SJW) determines the maximum number of system clock pulses by which the bit period can be lengthened or shortened for resynchronization. The synchronization jump width is programmable from 1 to $4 t_{SCL}$ (see bit-length register BL2).

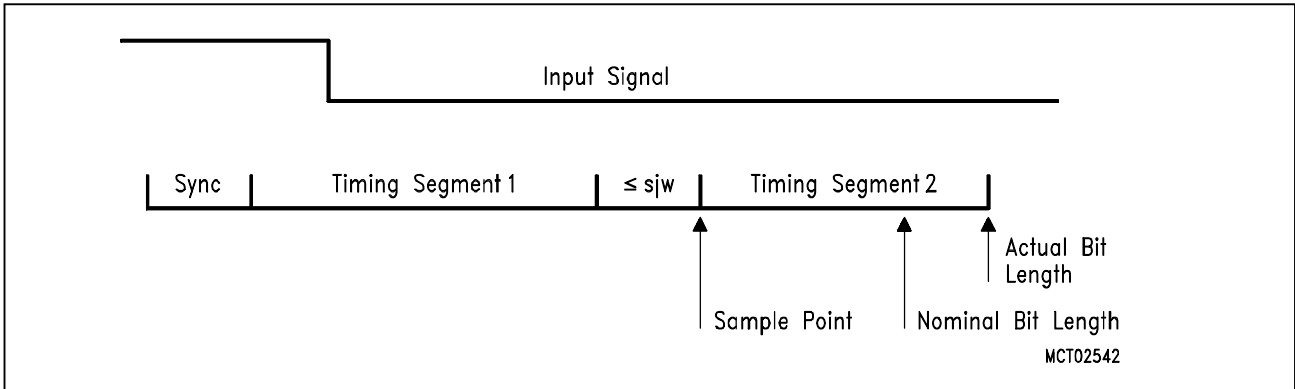

Figure 7
Lengthening a Bit Period

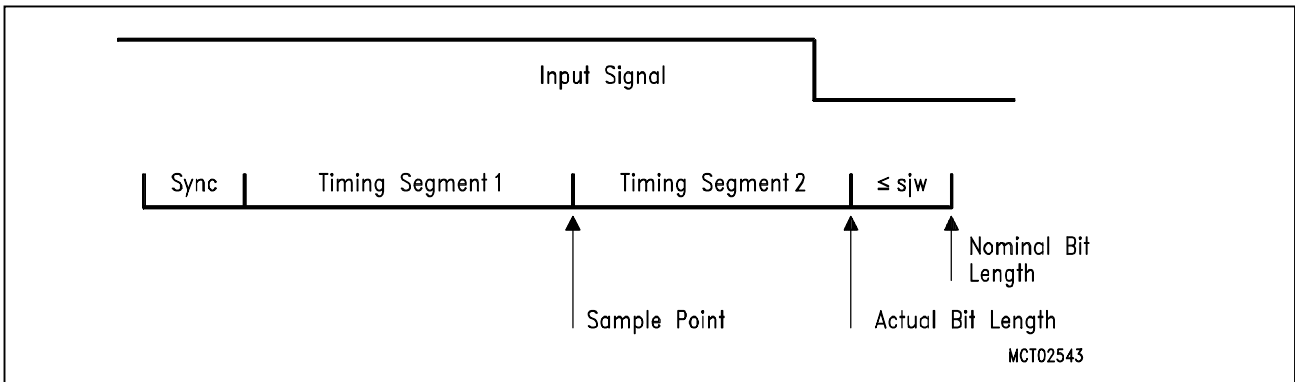

Figure 8
Shortening a Bit Period

Delay Times

The total delay is calculated from the following single delays:

- $2 \times$ physical bus t_{Bus} (max. 100 ns acc. to CAN specification)
- $2 \times$ input comparator t_{Comp} (depends on application circuit)
- $2 \times$ output driver t_{Driver} (depends on application circuit)
- $1 \times$ input to output of CAN controller t_{InOut} (max. $1 t_{SCL} + 80$ ns)

$$t_{Delay} = 2 \times (t_{Bus} + t_{Comp} + t_{Driver}) + t_{InOut}$$

Recommendations

On the premise of the stated conditions, there are the following essential requirements to be maintained:

$$\begin{aligned}
 t_{TSeg1} &\geq t_{Seg2} \\
 t_{TSeg1} &\geq t_{Delay} \\
 t_{TSeg2} &> t_{SJW} \\
 t_{TSeg2} &\geq 3 \times t_{SCL} + t_{SJW}
 \end{aligned}$$

if bit SAM = 1 (otherwise bit recognition does not work).

Host Interfaces

There are two different host interfaces implemented in the SAE 81C90/91.

Data and addresses on a multiplexed 8-bit bus, compatible with Siemens microcontrollers (C5xx, C16x), can be transferred via the parallel interface (PI). Using the serial synchronous interface (SI), any host controller with a serial three-lead interface can be connected with.

The interface is selected by hardware through the wiring of the MS (Mode Select) pin. This pin may not be switched during operation. If there is a High level on the MS pin, the SI and thus pins DI, DO, CLK, \overline{W} and TIM are activated, while pins AD5 through AD7, \overline{RD} , \overline{WR} and ALE are inactive. A Low level on the MS pin switches to the PI and thus activates pins AD0 through AD7, \overline{RD} , \overline{WR} and ALE.

Parallel Interface PI

The parallel interface uses a multiplexed 8-bit address/data bus. First the address of the required register is applied to the pins AD0 through AD7. A falling edge on pin ALE means that this address is transferred to an on-chip latch. After this, data can either be written into the selected register (pin $\overline{WR} = 0$) or read from it (pin $\overline{RD} = 0$) via the address/data bus. Pin \overline{CS} must be 0 for the entire duration of the $\overline{RD}/\overline{WR}$ active time so that the circuit is activated.

Serial Synchronous Interface SI

If the SI is used the unused pins of PI must be set to inactive levels (\overline{RD} , \overline{WR} to V_{DD} and ALE, AD5, AD6, AD7 to V_{SS}).

Communication on the SI is accomplished according to the following procedure:

Each access to the stand-alone Full-CAN circuit has to be started by activating the device ($\overline{CS} = 0$). After the beginning of access, an address must be written first and then data can be read or written. The required function is determined by pin \overline{W} ($\overline{W} = 1$: read; $\overline{W} = 0$: write). If the automatic decrementing of the address is activated (bit ADE in the MOD register), any number of data bytes can be accessed in succession. Finally the device has to be deactivated.

Procedure:

- Activate device ($\overline{CS} = 0$)
- Set pin \overline{W} to 1 for read, to 0 for write
- Write in address of first data byte
- Read out/write in one or more data bytes
- Deactivate device ($\overline{CS} = 1$)

The most-significant bit is always output as the first bit of an address or a data byte.

Data from pin DI are transferred into the internal shift register with the **rising** edge of the clock. The active clock edge of pin DO is selectable via the pin TIM. If this pin is 0 the data are output from the shift register to pin DO with the **rising** clock edge (Timing A). If the pin TIM is 1, the output of data is done with the **falling** edge (Timing B).

The timing for reading and writing of two data bytes with automatic decrementing activated is illustrated below.

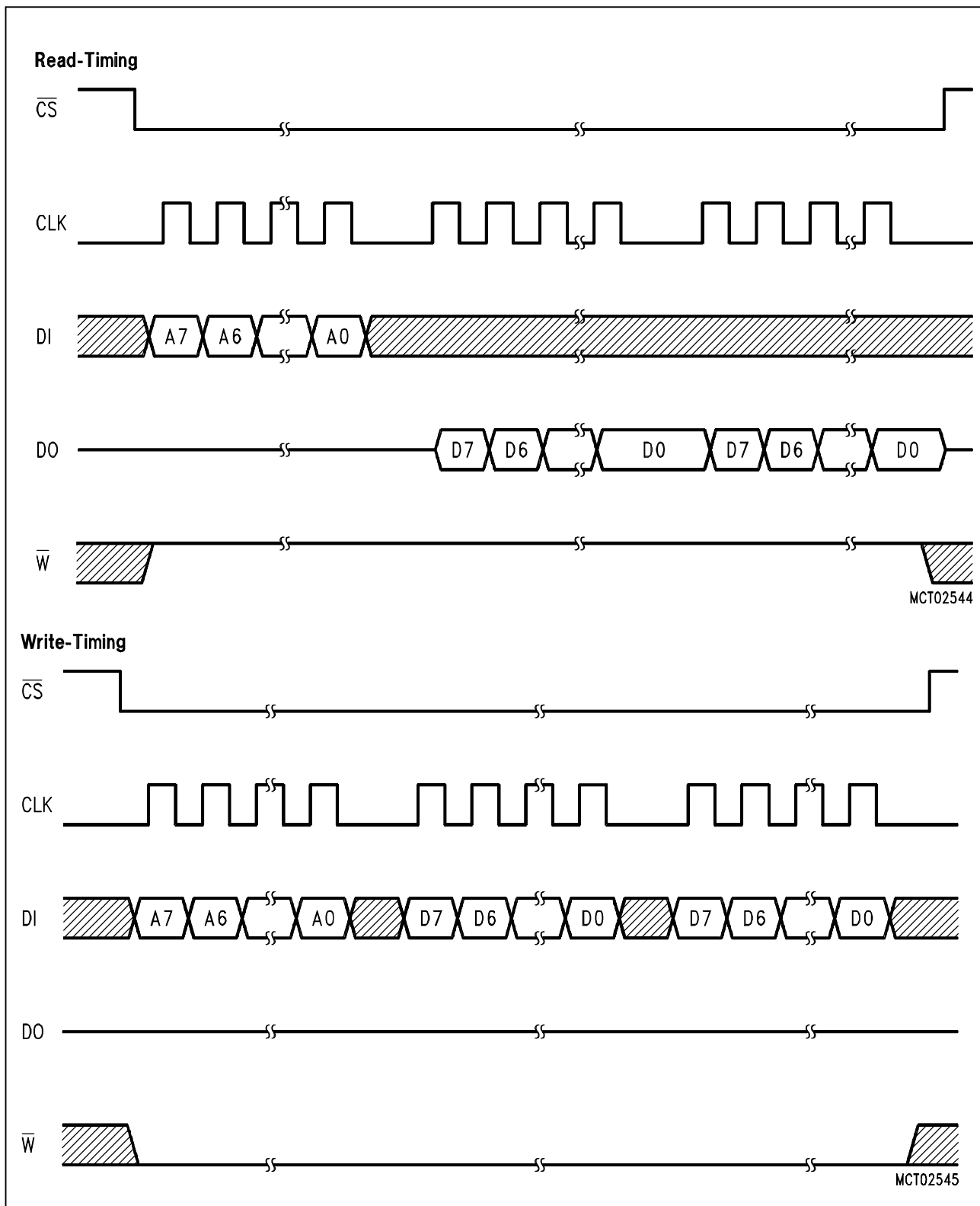

Figure 9
Serial Interface Timing (for 2 Data Bytes)

Absolute Maximum Ratings

Ambient temperature under bias (T_A):	- 40 to + 110 °C
Storage temperature (T_{ST}).....	- 50 to + 150 °C
Voltage on V_{CC} pins with respect to ground (V_{SS})	- 0.5 to + 6.0 V
Voltage on any pin with respect to ground (V_{SS}).....	- 0.5 to $V_{CC} + 0.5$ V
Input current on any pin during overload condition.....	- 10 to + 10 mA
Absolute sum of all input currents during overload condition	100 mA
Power dissipation.....	0.5 W

Note: Stresses above those listed under “Absolute Maximum Ratings” may cause permanent damage to the device. This is a stress rating only and functional operation of the device at these or any other conditions above those indicated in the operational sections of this specification is not implied. Exposure to absolute maximum rating conditions for extended periods may affect device reliability. During overload conditions ($V_{IN} > V_{CC}$ or $V_{IN} < V_{SS}$) the voltage on pins with respect to ground (V_{SS}) must not exceed the values defined by the Absolute Maximum Ratings.

Parameter Interpretation

The parameters listed in the following partly represent the characteristics of the SAE 81C90/91 and partly its demands on the system. To aid in interpreting the parameters right, when evaluating them for a design, they are marked in column “Symbol”:

DC (Device Characteristics):

The logic of the SAE 81C90/91 will provide signals with the respective timing characteristics.

SR (System Requirement):

The external system must provide signals with the respective timing characteristics to the SAE 81C90/91.

DC Characteristics

$$V_{CC} = 5\text{ V} \pm 10\%; \quad V_{SS} = 0\text{ V}$$

$$T_A = -40\text{ to }+110\text{ }^\circ\text{C}$$

Parameter	Symbol	Limit Values		Unit	Test Condition
		min.	max.		
Input low voltage (all except XTAL1 and XTAL2)	V_{IL} SR	0	$0.3 V_{CC}$	V	–
Input low voltage (XTAL1 and XTAL2)	V_{ILX} SR	0	0.5	V	–
Input high voltage (all except XTAL1 and XTAL2)	V_{IH} SR	$0.7 V_{CC}$	V_{CC}	V	–
Input high voltage (XTAL1 and XTAL2)	V_{IHx} SR	$V_{CC} - 1.0$	V_{CC}	V	–
Comparator input voltage ¹⁾	V_{CI} SR	0.5	$V_{CC} + 0.5$	V	–
Common mode voltage ²⁾	V_{ICOM} SR	1.5	$V_{CC} - 1.5$	V	–
Hysteresis ²⁾	V_{HYS} DC	–	100 ³⁾	mV	–
Offset voltage ²⁾	V_{OFF} DC	–	100 ³⁾	mV	–
Output low voltage (all except CLKOUT, TX0, TX1)	V_{OL} DC	–	$0.2 V_{CC}$	V	$I_{OL} = 1.6\text{ mA}$
Output low voltage (CLKOUT)	V_{OLC} DC	–	0.4	V	$I_{OL1} = 10\text{ mA}$
Output high voltage (all except CLKOUT, TX0, TX1)	V_{OH} DC	$0.8 V_{CC}$	V_{CC}	V	$I_{OH} = -1.6\text{ mA}$
Output high voltage (CLKOUT)	V_{OHC} DC	$V_{CC} - 0.8$	V_{CC}	V	$I_{OH} = -10\text{ mA}$
Input leakage current	I_I DC	–	± 1	μA	$0\text{ V} < V_{IN} < V_{CC}$ ⁴⁾
Source output current (TX0, TX1)	I_{SRC} DC	5	–	mA	$V_O = V_{CC} - 1\text{ V}$
Sink output current (TX0, TX1)	I_{SNK} DC	5	–	mA	$V_O = 1\text{ V}$
Low end capacitance ⁵⁾	C_L DC	6.8	12	pF	
Pin capacitance ²⁾	C_1 DC	–	10	pF	$f = 1\text{ MHz}$ $T_A = 25\text{ }^\circ\text{C}$
Power supply current	I_{CC}	–	30	mA	

Notes

- 1) If the bus lines work according to the ISO specification, additional circuitry is necessary for interconnection of the input comparator to the bus lines.
- 2) Not 100% tested, guaranteed by design characterization.
- 3) This value is a typical value!
- 4) This specification does not apply to the port pins (P00...P07, P10...P17) due to the implemented pullups!
- 5) In oscillator mode the size of the low-end capacitance must correspond to the specification of the crystal manufacturer. The optimum values depend on the selected crystal, the intended frequency and the actual application hardware (stray capacitances). 10 pF are recommended for C_L .
For best results keep the crystal circuitry connections as short as possible and keep the CLKOUT line away from it. If the CLKOUT signal is not required by the system it should be switched off.

AC Characteristics (General Timing)

$V_{CC} = 5\text{ V} \pm 10\%$; $V_{SS} = 0\text{ V}$
 $T_A = -40\text{ to }+110\text{ }^\circ\text{C}$

Parameter	Symbol	Limit Values		Unit	Test Conditions
		min.	max.		
Oscillator period	t_{OSC} SR	50	-	ns	
Clock input high time	t_H SR	23.5	-	ns	
Clock input low time	t_L SR	23.5	-	ns	
Reset pulse width	t_{RES} SR	2	-	t_{OSC}	
Output rise time ¹⁾	t_{QR} DC	-	40	ns	$C_L = 70\text{ pF}$
Output fall time ¹⁾	t_{QF} DC	-	40	ns	$C_L = 70\text{ pF}$
CLKOUT rise time ¹⁾	t_{QRC} DC	-	20	ns	$C_L = 50\text{ pF}$
CLKOUT fall time ¹⁾	t_{QFC} DC	-	20	ns	$C_L = 50\text{ pF}$

¹⁾ Not 100% tested, guaranteed by design characterization.

AC Characteristics (SI Timing)

$V_{CC} = 5\text{ V} \pm 10\%$; $V_{SS} = 0\text{ V}$
 $T_A = -40\text{ to }+110\text{ }^\circ\text{C}$; $C_L = 50\text{ pF}$

Parameter	Symbol	Limit Values		Unit	Test Conditions
		min.	max.		
Chip Select Setup	t_{CSS} SR	10		ns	
Clock High Time	t_{CH} SR	$1.5 t_{OSC} + 10$		ns	
Clock Low Time	t_{CL} SR	$1.5 t_{OSC} + 10$		ns	
Clock Period	t_C SR	$4 t_{OSC}$		ns	
DI Setup	t_{DIS} SR	10		ns	
DI Hold	t_{DIH} SR	0		ns	
Address to Data Out	t_{ADO} DC	$3 t_{OSC}$		ns	
Output Delay	t_{OD} DC		25	ns	
Data Float after \overline{CS} high	t_{DF} DC		25	ns	
Chip Select Hold	t_{CSH} SR	$1 t_{OSC}$		ns	
Write to Clock	t_{WC}	0		ns	
\overline{W} to \overline{CS} high	t_{WCS} SR	0		ns	
Address to Data In	t_{ADI} DC	0		ns	

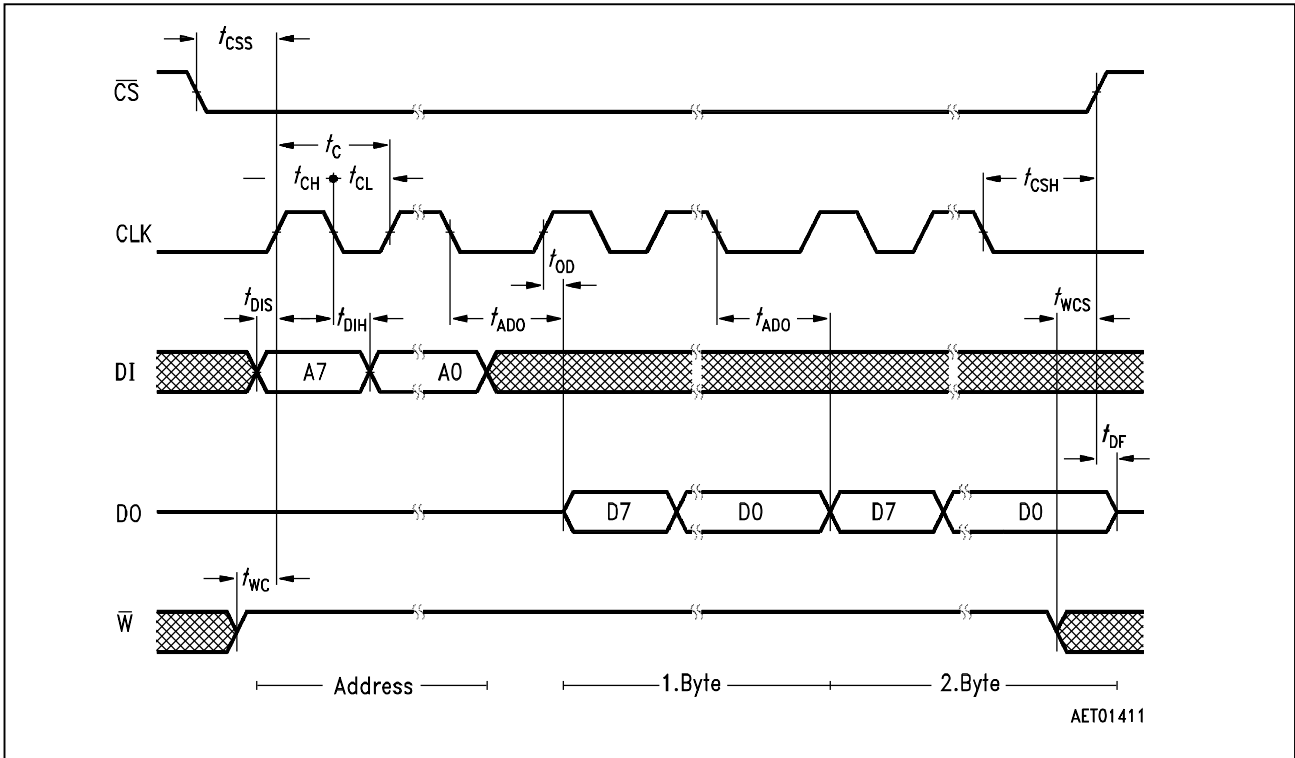

Figure 10
SI-Read-Timing (Timing A: Pin TIM = 0)

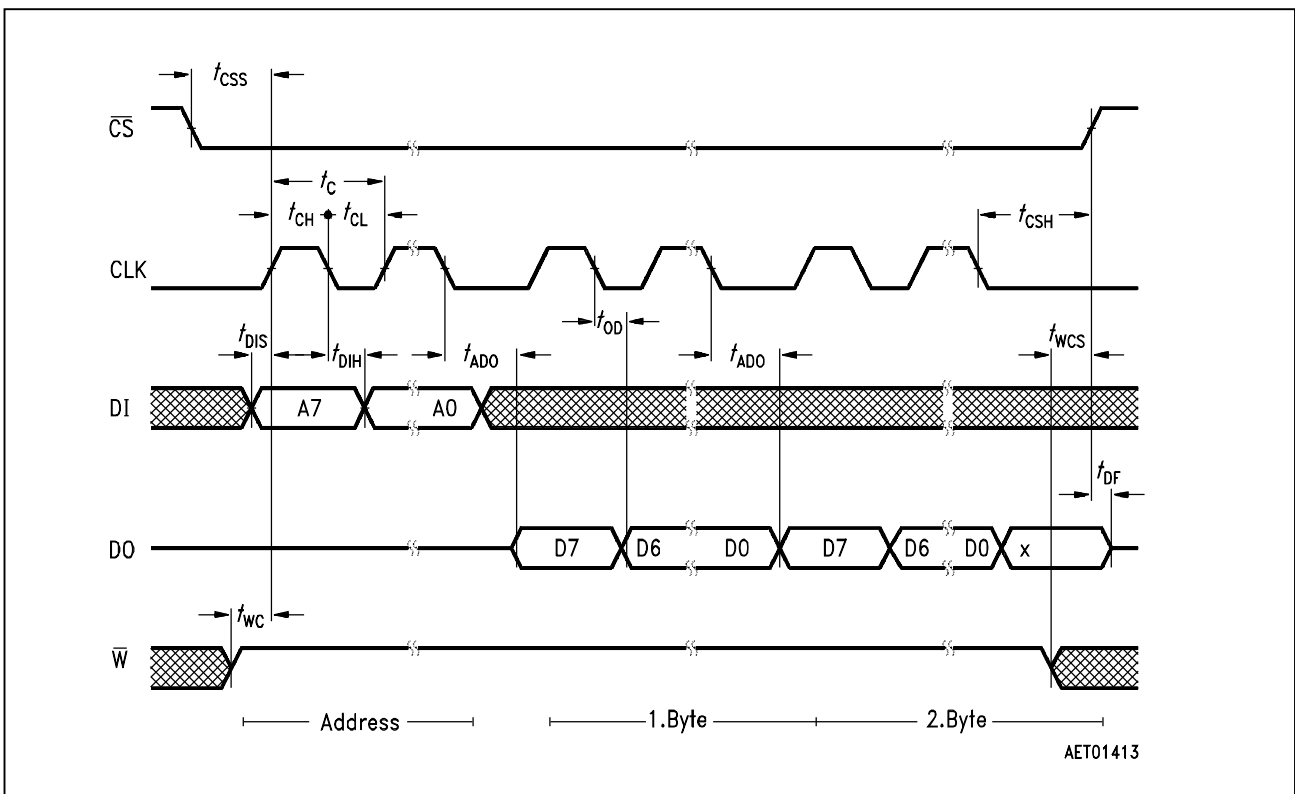

Figure 11
SI-Read-Timing (Timing B: Pin TIM = 1)

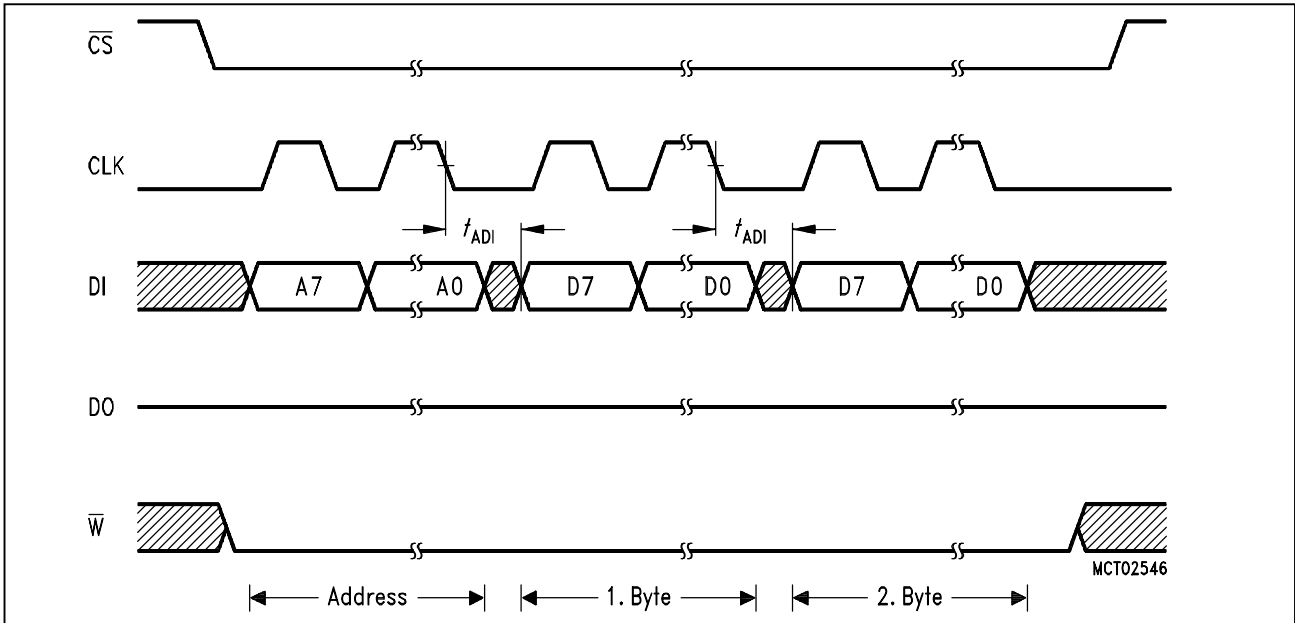
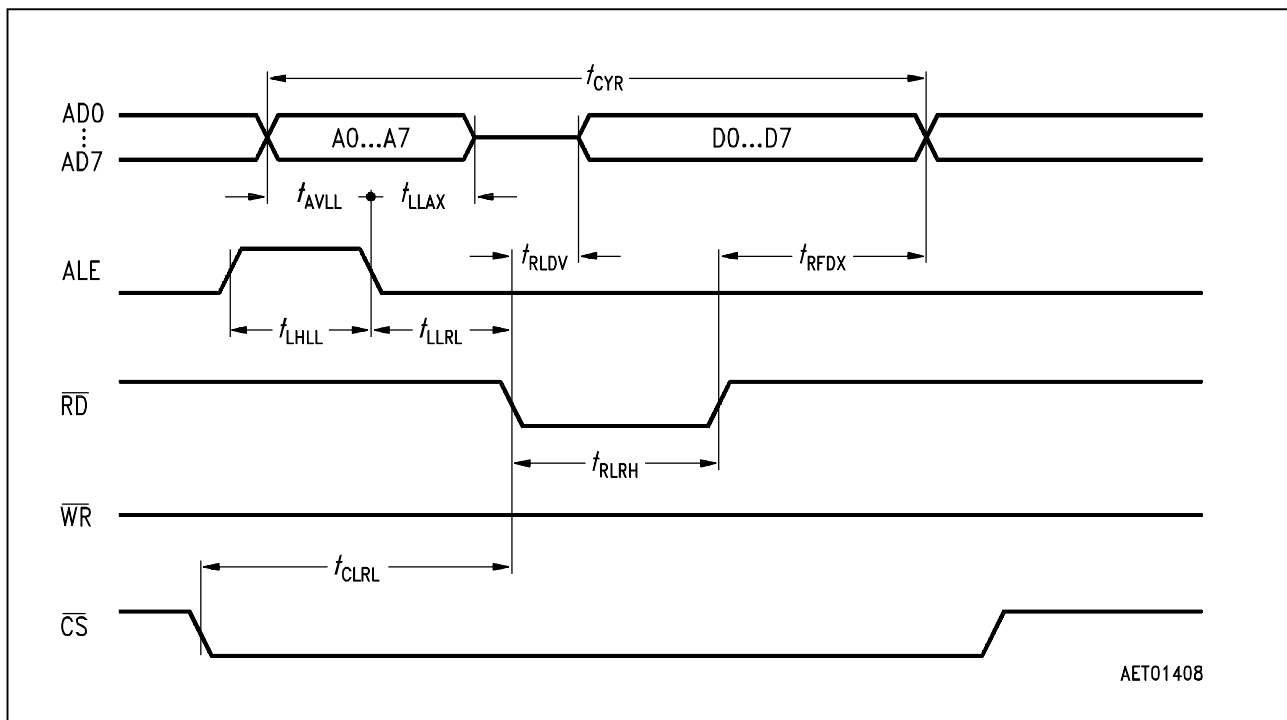

Figure 12
SI-Write-Timing

AC Characteristics (PI Timing)

$V_{CC} = 5\text{ V} \pm 10\%$; $V_{SS} = 0\text{ V}$
 $T_A = -40\text{ to }+110\text{ }^\circ\text{C}$; $C_L = 50\text{ pF}$

Parameter	Symbol	Limit Values		Unit	Test Condition
		min.	max.		
Read-Cycle time	t_{CYR} DC	$4 t_{OSC}$		ns	
Write-Cycle time	t_{CYW} DC	$4 t_{OSC}$		ns	
ALE pulse width	t_{LHLL} DC	30		ns	
Address setup to ALE low	t_{AVLL} SR	10		ns	
Address hold after ALE low	t_{LLAX} SR	10		ns	
\overline{RD} pulse width	t_{RLRH} SR	$2 t_{OSC} + 30$		ns	
\overline{WR} pulse width	t_{WLWH} SR	$2 t_{OSC} + 30$		ns	
ALE low to \overline{WR} active	t_{LLWL} SR	20		ns	
ALE low to \overline{RD} active	t_{LLRL} SR	20		ns	
Data float after \overline{RD} high	t_{RFDX} DC	0	20	ns	
\overline{RD} low to data valid	t_{RLDV} DC		$2 t_{OSC} + 20$	ns	
Data setup before \overline{WR} high	t_{DVWH} SR	10		ns	
Data hold after \overline{WR} high	t_{WHDX} SR	5		ns	
\overline{CS} low to \overline{RD} low	t_{CLRL} / SR	0		ns	
\overline{CS} low to \overline{WR} low	t_{CLWL} SR	0		ns	
\overline{WR} high to next ALE low	t_{WHLL} SR	$1.5 t_{OSC}$		ns	



AET01408

Figure 13
PI Timing: Read-Cycle-Timing

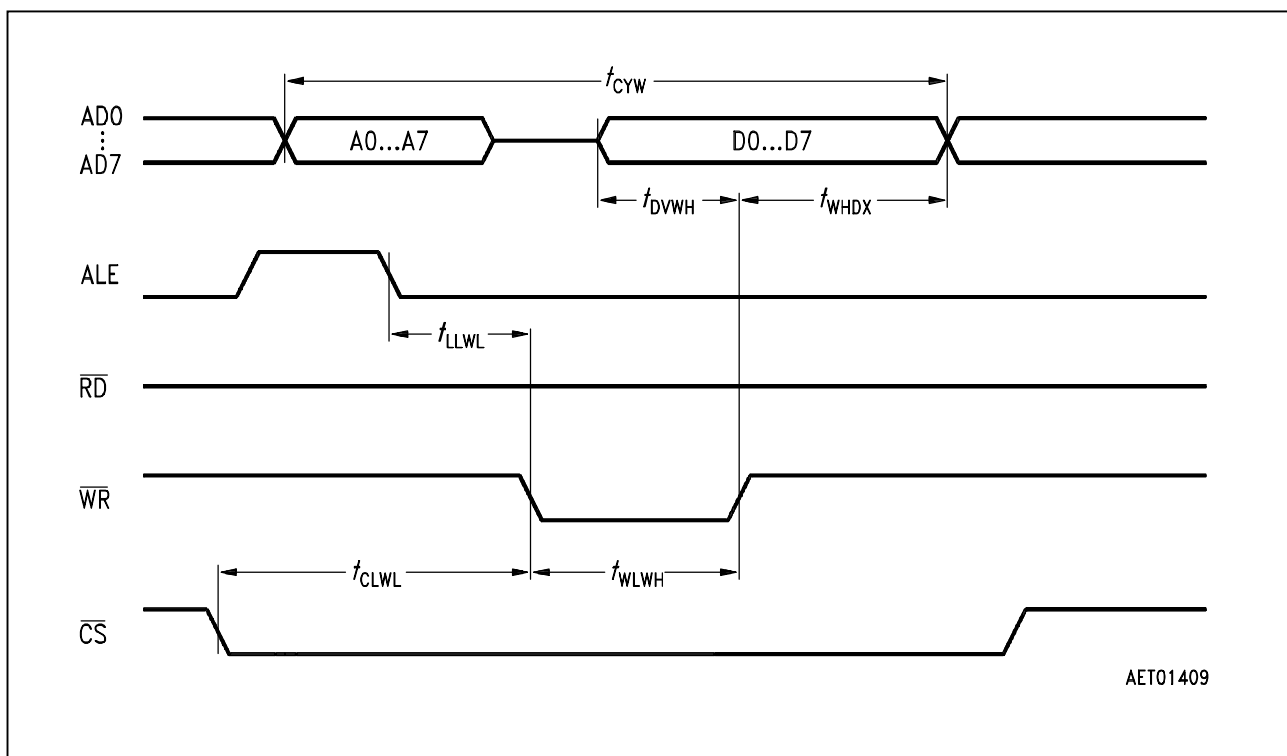

AET01409

Figure 14
PI Timing: Write-Cycle-Timing