

Typical Applications

- 3V Dual-Band GSM Handsets
- Commercial and Consumer Systems
- Portable Battery-Powered Equipment
- GSM, E-GSM and DCS/PCS Products
- GPRS Class 10 Compatible

Product Description

The RF3110 is a high-power, high-efficiency power amplifier module with integrated power control. The device is self-contained with 50Ω input and output terminals. The power control function is also incorporated, eliminating the need for directional couplers, detector diodes, power control ASICs and other power control circuitry; this allows the module to be driven directly from the DAC output. The device is designed for use as the final RF amplifier in GSM/DCS and PCS handheld digital cellular equipment and other applications in the 880MHz to 915MHz, 1710MHz to 1785MHz and 1850MHz to 1910MHz bands. On-board power control provides over 35dB of control range with an analog voltage input; and, power down with a logic “low” for standby operation.

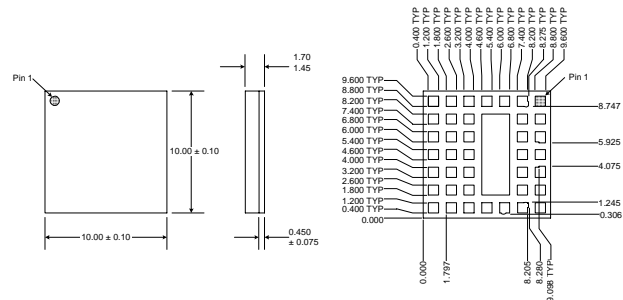

Optimum Technology Matching® Applied

- Si BJT GaAs HBT GaAs MESFET
 Si Bi-CMOS SiGe HBT Si CMOS

Package Style: Module

Features

- Complete Power Control Solution
- Single 2.9V to 5.5V Supply Voltage
- +35dBm GSM Output Power at 3.5V
- +33dBm DCS/PCS Output Power at 3.5V
- 55% GSM and 55% DCS/PCS η_{EFF}
- 10mmx10mm Package Size

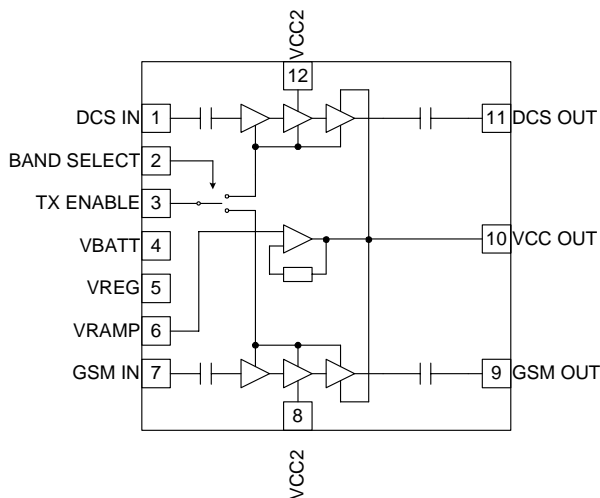

Functional Block Diagram

Ordering Information

RF3110	Triple-Band GSM/DCS/PCS Power Amp Module
RF3110 PCBA	Fully Assembled Evaluation Board

RF Micro Devices, Inc. Tel (336) 664 1233
 7628 Thorndike Road Fax (336) 664 0454
 Greensboro, NC 27409, USA <http://www.rfmd.com>

Absolute Maximum Ratings

Parameter	Rating	Unit
Supply Voltage	-0.5 to +6.0	V _{DC}
Power Control Voltage (V _{RAMP})	-0.5 to +1.8	V
Input RF Power	+11.5	dBm
Duty Cycle at Max Power	37.5	%
Output Load VSWR	8:1	
Operating Case Temperature	-40 to +85	°C
Storage Temperature	-55 to +150	°C



Caution! ESD sensitive device.

RF Micro Devices believes the furnished information is correct and accurate at the time of this printing. However, RF Micro Devices reserves the right to make changes to its products without notice. RF Micro Devices does not assume responsibility for the use of the described product(s).

2

POWER AMPLIFIERS

Parameter	Specification			Unit	Condition
	Min.	Typ.	Max.		
Overall (GSM Mode)					Temp=+25 °C, V _{CC} =3.5V, V _{RAMP} Max, V _{RAMP} =V _{RAMP} Max, P _{IN} =6dBm, Freq=880MHz to 915MHz, 12.5% Duty Cycle, Pulse Width=577µs
Operating Frequency Range		880 to 915		MHz	
Maximum Output Power	+34.5	35.0		dBm	Temp = 25 °C, V _{CC} =3.5V, V _{RAMP} =V _{RAMP} Max
	+32.0			dBm	Temp=+85 °C, V _{CC} =2.9V, V _{RAMP} =V _{RAMP} Max
Total Efficiency		55		%	At P _{OUT,MAX} , V _{CC} =3.5V
Input Power Range	+4	+6	+8	dBm	Full output power guaranteed at minimum drive level
Output Noise Power		-86		dBm	RBW=100kHz, 925MHz to 935MHz, P _{OUT} ≥ +5dBm
		-88		dBm	RBW=100kHz, 935MHz to 960MHz, P _{OUT} ≥ +5dBm
Forward Isolation		-35	-30	dBm	TX_ENABLE=0V, PIN=+8dBm
Second Harmonic		-15	-5	dBm	
Third Harmonic		-30	-15	dBm	
All other Non-Harmonic Spurious			-36	dBm	
Input Impedance		50		Ω	
Input VSWR			2.5:1		
Output Load VSWR	8:1				P _{OUT,MAX} -5dB<P _{OUT} <P _{OUT,MAX} Spurious<-36dBm, V _{RAMP} =0.2V to 1.6V, RBW=3MHz
Output Load Impedance		50		Ω	Load impedance presented at RF OUT pad
Power Control V_{RAMP}					
Power Control "ON"			1.6	V	Max. P _{OUT} , Voltage supplied to the input
Power Control "OFF"		0.2	0.25	V	Min. P _{OUT} , Voltage supplied to the input
Power Control Range		35		dB	V _{RAMP} =0.2V to 1.6V
V _{RAMP} Input Capacitance		15		pF	DC to 2MHz
V _{RAMP} Input Current			10	µA	V _{RAMP} =1.6V
Turn On/Off Time			4	µS	V _{RAMP} =0 to 1.6V

Note: V_{RAMP} Max=3/8*VBATT+0.18≤1.6V

Parameter	Specification			Unit	Condition
	Min.	Typ.	Max.		
Overall Power Supply					
Power Supply Voltage	2.9	3.5	5.5	V	Specifications
Power Supply Current		2		A	Nominal operating limits, P _{OUT} <+33dBm
V _{REG} Voltage	2.7	2.8	2.9	V	DC Current at P _{OUT,MAX}
V _{REG} Current		7		mA	P _{IN} <-30dBm, V _{RAMP} =0V,
		10		μA	Temp=-40°C to +85°C
					TX Enable=High
					TX Enable=Low
Overall (DSC/PCS Mode)					Temp=25°C, V _{CC} =3.5V, V _{RAMP} =V _{RAMP}
Operating Frequency Range		1710 to 1910		MHz	Max, P _{IN} =6dBm, Freq=1710MHz to
Maximum Output Power	+32	+33		dBm	1785MHz, 12.5% Duty Cycle, pulse
		31.5		dBm	width=577μs
		30		dBm	Temp=25°C, V _{CC} =3.5V, V _{RAMP} =V _{RAMP}
		29.5		dBm	Max, 1710MHz to 1785MHz
Total Efficiency	45	52		%	1850-1910MHz
		45			Temp=+85°C, V _{CC} =2.9V, V _{RAMP} =V _{RAMP}
Input Power Range	+4	+6	+8	dBm	Max, 1710MHz to 1785MHz
Output Noise Power			-77	dBm	1850MHz to 1910MHz
Forward Isolation		-37	-30	dBm	At P _{OUT,MAX} , V _{CC} =3.5V, 1710-1785MHz
Second Harmonic		-25	-15	dBm	1850-1910MHz
Third Harmonic		-30	-15	dBm	Full output power guaranteed at minimum
All other Non-Harmonic Spurious			-36	dBm	drive level
Input Impedance		50		Ω	RBW=100kHz, 1805MHz to 1880MHz and
Input VSWR		-	2.5		1930MHz to 1990MHz, P _{OUT} ≥ 34.5dBm,
Output Load VSWR	8:1				V _{CC} =3.5V
Output Load Impedance		50		Ω	TX_ENABLE=0V, P _{IN} =+8dBm
					P _{OUT} = +32.5dBm
Power Control V_{RAMP}					
Power Control "ON"			1.6	V	Max. P _{OUT} , Voltage supplied to the input
Power Control "OFF"		0.2	0.25	V	Min. P _{OUT} , Voltage supplied to the input
Power Control Range		33		dB	V _{RAMP} =0.15V to 1.6V, P _{IN} =+8dBm
V _{RAMP} Input Capacitance		15		pF	DC to 2MHz
V _{RAMP} Input Current			10	μA	V _{RAMP} =1.6V
			10	μA	V _{RAMP} =0V
Turn On/Off Time			4	μs	V _{RAMP} =0 to 1.6V

Note: V_{RAMP} max=3/8*VBATT+0.18≤1.6V

Parameter	Specification			Unit	Condition
	Min.	Typ.	Max.		
Overall Power Supply					
Power Supply Voltage		3.5		V	Specifications Nominal operating limits, P _{OUT} <+33dBm DC Current at P _{OUT,MAX} P _{IN} <-30dBm, V _{RAMP} =0V, Temp=-40°C to +85°C
	2.9		5.5	V	
Power Supply Current		1.3		A	
		1	10	μA	
V _{REG} Voltage	2.7	2.8	2.9	V	
V _{REG} Current		7		mA	TX Enable=High
		10		μA	TX Enable=Low

Pin	Function	Description	Interface Schematic
1	DCS IN	RF input to the DCS band. This is a 50Ω input.	
2	BAND SELECT	Allows external control to select the GSM or DCS band with a logic high or low. A logic low enables the GSM band whereas a logic high enables the DCS band.	
3	TX ENABLE	This signal enables the PA module for operation with a logic high. Once TX Enable is asserted the RF output level will increase to 0dBm.	
4	VBATT	Power supply for the module. This should be connected to the battery.	
5	VREG	Regulated voltage input for power control function. (2.8V nom)	
6	VRAMP	Ramping signal from DAC. A simple RC filter may need to be connected between the DAC output and the VRAMP input depending on the baseband selected. The ramping profiles shown later in the data sheet are recommended profiles for meeting the GSM specification for burst timing and transient spectrum.	
7	GSM IN	RF input to the GSM band. This is a 50Ω input.	
8	VCC2	Controlled voltage input to driver stage for GSM bands. This voltage is part of the power control function for the module. This node must be connected to V _{CC} out.	
9	GSM OUT	RF output for the GSM band. This is a 50Ω output. The output load line matching is contained internal to the package.	
10	VCC OUT	Controlled voltage output to feed V _{CC2} . This voltage is part of the power control function for the module. It can not be connected to anything other than V _{CC2} , nor can any component be placed on this node (i.e. decoupling capacitor).	
11	DCS OUT	RF output for the DCS band. This is a 50Ω output. The output load line matching is contained internal to the package.	
12	VCC2	Controlled voltage input to DCS driver stage. This voltage is part of the power control function for the module. This node must be connected to V _{CC} out	
Pkg Base	GND		

Pin Out

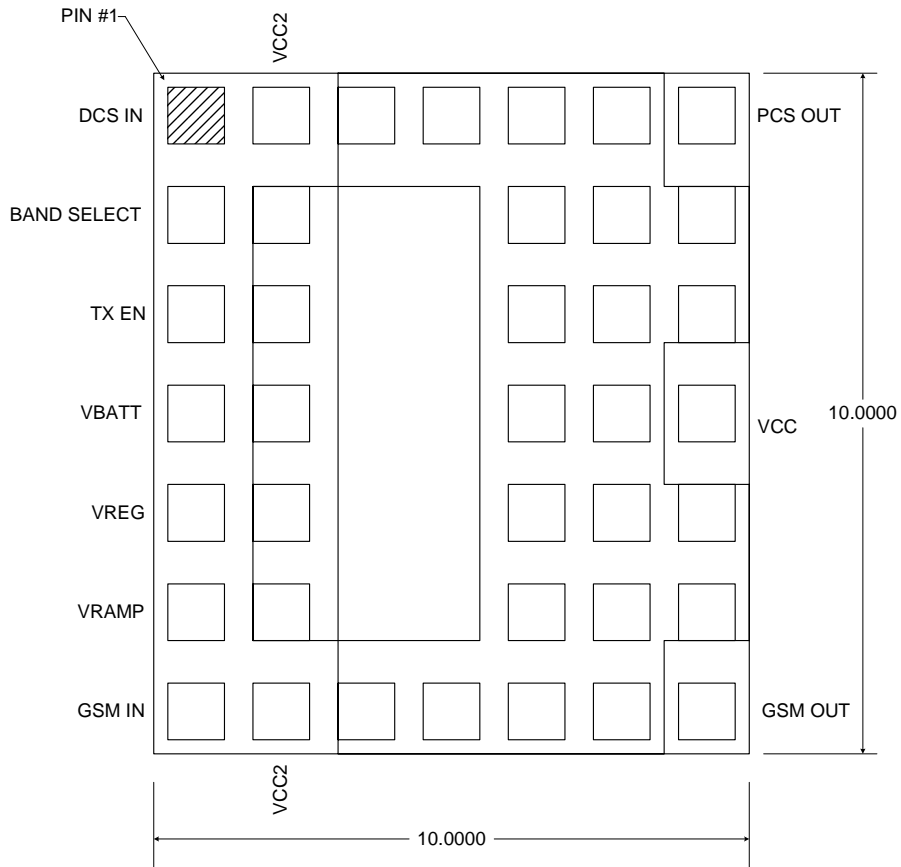

2
POWER AMPLIFIERS

Application Schematic

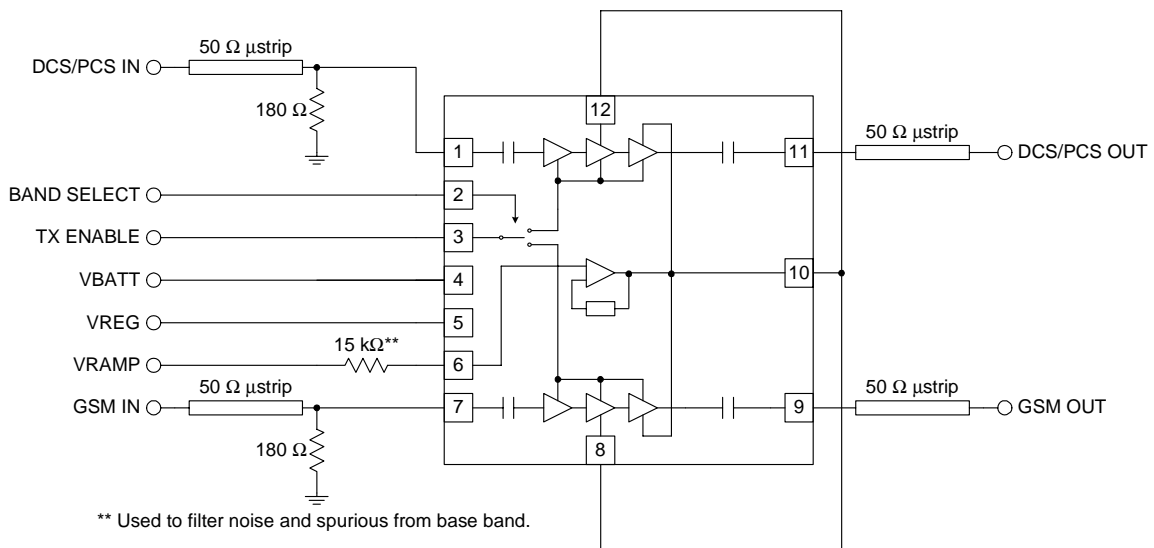

Evaluation Board Schematic

(Download [Bill of Materials](http://www.rfmd.com) from www.rfmd.com.)

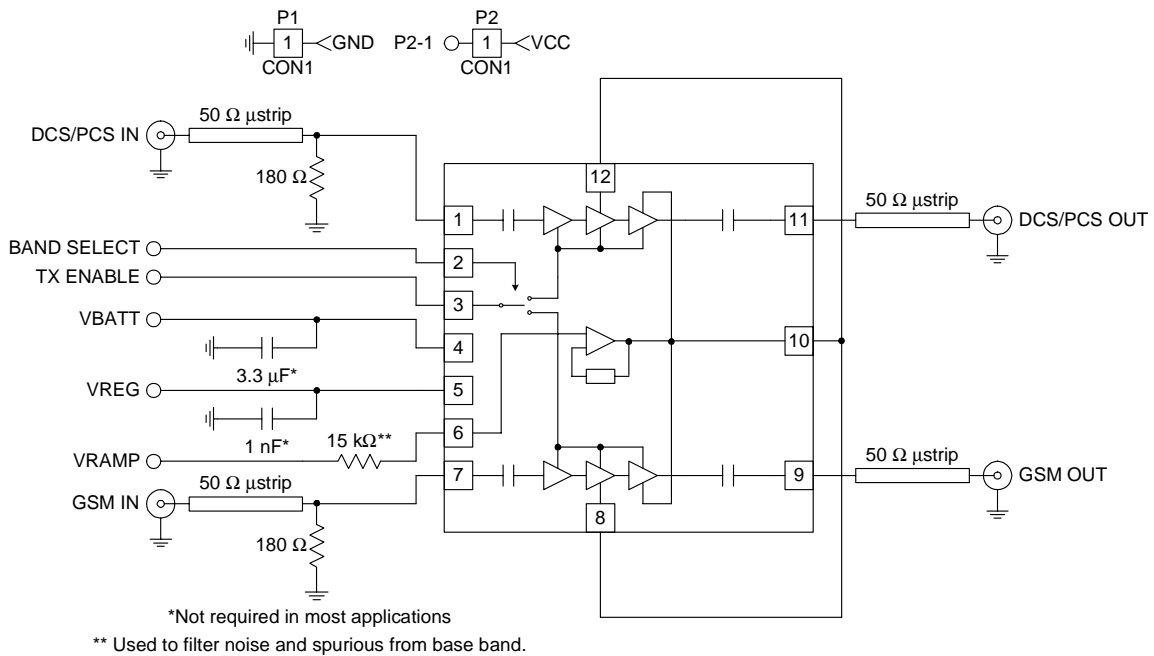

Theory of Operation

Overview

The RF3110 is a triple-band GSM/DCS/PCS power amplifier module that incorporates an indirect closed loop method of power control. This simplifies the phone design by eliminating the need for the complicated control loop design. The indirect closed loop is fully self contained and required does not require loop optimization. It can be driven directly from the DAC output in the baseband circuit.

Theory of Operation

The indirect closed loop is essentially a closed loop method of power control that is invisible to the user. Most power control systems in GSM sense either forward power or collector/drain current. The RF3110 does not use a power detector. A high-speed control loop is incorporated to regulate the collector voltages of the amplifier while the stages are held at a constant bias. The V_{RAMP} signal is multiplied and the collector voltages are regulated to the multiplied V_{RAMP} voltage. The basic circuit is shown in the following diagram.

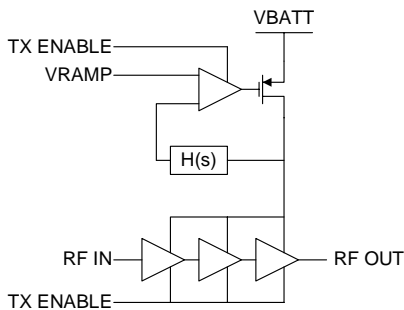

By regulating the power, the stages are held in saturation across all power levels. As the required output power is decreased from full power down to 0dBm, the collector voltage is also decreased. This regulation of output power is demonstrated in Equation 1 where the relationship between collector voltage and output power is shown. Although load impedance affects output power, supply fluctuations are the dominate mode of power variations. With the RF3110 regulating collector voltage, the dominant mode of power fluctuations is eliminated.

$$P_{dBm} = 10 \cdot \log \left[\frac{(2 \cdot V_{CC} - V_{SAT})^2}{8 \cdot R_{LOAD} \cdot 10^{-3}} \right] \quad (\text{Eq. 1})$$

There are several key factors to consider in the implementation of a transmitter solution for a mobile phone. Some of them are:

- Effective efficiency (η_{eff})
- Current draw and system efficiency
- Power variation due to Supply Voltage
- Power variation due to frequency
- Power variation due to temperature
- Input impedance variation
- Noise power
- Loop stability
- Loop bandwidth variations across power levels
- Burst timing and transient spectrum trade offs
- Harmonics

Talk time and power management are key concerns in transmitter design since the power amplifier has the highest current draw in a mobile terminal. Considering only the power amplifier's efficiency does not provide a true picture for the total system efficiency. It is important to consider effective efficiency which is represented by η_{EFF} . (η_{EFF} considers the loss between the PA and antenna and is a more accurate measurement to determine how much current will be drawn in the application). η_{EFF} is defined by the following relationship (Equation 2):

$$\eta_{EFF} = \frac{\sum_{n=1}^m P_N - P_{IN}}{P_{DC}} \cdot 100 \quad (\text{Eq. 4})$$

Where P_n is the sum of all positive and negative RF power, P_{IN} the input power and P_{DC} is the delivered DC power. In dB the formula becomes (Equation 3):

$$\eta_{EFF} = \frac{10^{\frac{P_{PA} + P_{LOSS}}{10}} - 10^{\frac{P_{IN}}{10}}}{V_{BAT} \cdot I_{BAT} \cdot 10} \quad (\text{Eq. 3})$$

Where P_{PA} is the output power from the PA, P_{LOSS} the insertion loss, P_{IN} the input power to the PA and P_{DC} the delivered DC power.

The RF3110 improves the effective efficiency by minimizing the P_{LOSS} term in the equation. A directional coupler may introduce 0.4 dB to 0.5 dB loss to the transit path. To demonstrate the improvement in effective efficiency consider the following example:

Conventional PA Solution:

$$\begin{array}{l} P_{PA} = +33 \text{ dBm} \\ P_{IN} = +6 \text{ dBm} \\ P_{LOSS} = -0.4 \text{ dB} \\ V_{BAT} = 3.5 \text{ V} \\ I_{BAT} = 1.1 \text{ A} \end{array} \Rightarrow \eta_{EFF} = 47.2\%$$

RF3110 Solution:

$$\begin{array}{l} P_{PA} = +33 \text{ dBm} \\ P_{IN} = +6 \text{ dBm} \\ P_{LOSS} = 0 \text{ dB} \\ V_{BAT} = 3.5 \text{ V} \\ I_{BAT} = 1.1 \text{ A} \end{array} \Rightarrow \eta_{EFF} = 51.72\%$$

The RF3110 solution improves effective efficiency 5%.

Output power does not vary due to supply voltage under normal operating conditions if V_{RAMP} is sufficiently lower than V_{BATT} . By regulating the collector voltage to the PA the voltage sensitivity is essentially eliminated. This covers most cases where the PA will be operated. However, as the battery discharges and approaches its lower power range the maximum output power from the PA will also drop slightly. In this case it is important to also decrease V_{RAMP} to prevent the power control from inducing switching transients. These transients occur as a result of the control loop slowing down and not regulating power in accordance with V_{RAMP} .

The switching transients due to low battery conditions are regulated by incorporating the following relationship limiting the maximum V_{RAMP} voltage (Equation 2). Although no compensation is required for typical battery conditions, the battery compensation required for extreme conditions is covered by the relationship in Equation 4. This should be added to the terminal software.

$$V_{RAMP} \leq \frac{3}{8} \cdot V_{BATT} + 0.18 \quad (\text{Eq. 4})$$

Note: Output power is limited by battery voltage. The relationship in Equation 4 does not limit output power. Equation 4 limits the V_{RAMP} voltage to correspond with the battery voltage.

Due to reactive output matches, there are output power variations across frequency. There are a number of components that can make the effects greater or less.

The components following the power amplifier often have insertion loss variation with respect to frequency. Usually, there is some length of microstrip that follows the power amplifier. There is also a frequency response found in directional couplers due to variation in the coupling factor over frequency, as well as the sensitivity of the detector diode. Since the RF3110 does not use a directional coupler with a diode detector, these variations do not occur.

Input impedance variation is found in most GSM power amplifiers. This is due to a device phenomena where C_{BE} and C_{CB} (C_{GS} and C_{SG} for a FET) vary over the bias voltage. The same principle used to make varactors is present in the power amplifiers. The junction capacitance is a function of the bias across the junction. This produces input impedance variations as the V_{apc} voltage is swept. Although this could present a problem with frequency pulling the transmit VCO off frequency, most synthesizer designers use very wide loop bandwidths to quickly compensate for frequency variations due to the load variations presented to the VCO.

The RF3110 presents a very constant load to the VCO. This is because all stages of the RF3110 are run at constant bias. As a result, there is constant reactance at the base emitter and base collector junction of the input stage to the power amplifier.

Noise power in PA's where output power is controlled by changing the bias voltage is often a problem when backing off of output power. The reason is that the gain is changed in all stages and according to the noise formula (Equation 5),

$$F_{TOT} = F1 + \frac{F2 - 1}{G1} + \frac{F3 - 1}{G1 \cdot G2} \quad (\text{Eq. 5})$$

the noise figure depends on noise factor and gain in all stages. Because the bias point of the RF3110 is kept constant the gain in the first stage is always high and the overall noise power is not increased when decreasing output power.

Power control loop stability often presents many challenges to transmitter design. Designing a proper power control loop involves trade-offs affecting stability, transient spectrum and burst timing.

In conventional architectures the PA gain (dB/ V) varies across different power levels, and as a result the loop bandwidth also varies. With some power amplifiers it is possible for the PA gain (control slope) to change from 100dB/V to as high as 1000dB/V. The challenge in this scenario is keeping the loop bandwidth wide enough to meet the burst mask at low slope regions which often causes instability at high slope regions.

The RF3110 loop bandwidth is determined by internal bandwidth and the RF output load and does not change with respect to power levels. This makes it easier to maintain loop stability with a high bandwidth loop since the bias voltage and collector voltage do not vary.

An often overlooked problem in PA control loops is that a delay not only decreases loop stability it also affects the burst timing when, for instance the input power from the VCO decreases (or increases) with respect to temperature or supply voltage. The burst timing then appears to shift to the right especially at low power levels. The RF3110 is insensitive to a change in input power and the burst timing is constant and requires no software compensation.

Switching transients occur when the up and down ramp of the burst is not smooth enough or suddenly changes shape. If the control slope of a PA has an inflection point within the output power range or if the slope is simply too steep it is difficult to prevent switching transients. Controlling the output power by changing the collector voltage is as earlier described based on the physical relationship between voltage swing and output power. Furthermore all stages are kept constantly biased so inflection points are nonexistent.

Harmonics are natural products of high efficiency power amplifier design. An ideal class "E" saturated power amplifier will produce a perfect square wave. Looking at the Fourier transform of a square wave reveals high harmonic content. Although this is common to all power amplifiers, there are other factors that contribute to conducted harmonic content as well. With most power control methods a peak power diode detector is used to rectify and sense forward power. Through the rectification process there is additional squaring of the waveform resulting in higher harmonics. The RF3110 address this by eliminating the need for the detector diode. Therefore the harmonics coming out of the PA should represent the maximum power of the harmonics throughout the transmit chain. This is based upon proper harmonic termination of the transmit port. The receive port termination on the T/R switch as well as the harmonic impedance from the switch itself will have an impact on harmonics. Should a problem arise, these terminations should be explored.

The RF3110 incorporates many circuits that had previously been required external to the power amplifier. The shaded area of the diagram below illustrates those components and the following table itemizes a comparison between the RF3110 Bill of Materials and a conventional solution:

Component	Conventional Solution	RF3110
Power Control ASIC	\$0.80	N/A
Directional Coupler	\$0.20	N/A
Buffer	\$0.05	N/A
Attenuator	\$0.05	N/A
Various Passives	\$0.05	N/A
Mounting Yield (other than PA)	\$0.12	N/A
Total	\$1.27	\$0.00

Note: Output power is limited by battery voltage. The relationship in Equation 4 does not limit output power. Equation 4 limits V_{RAMP} to correspond with the battery voltage.

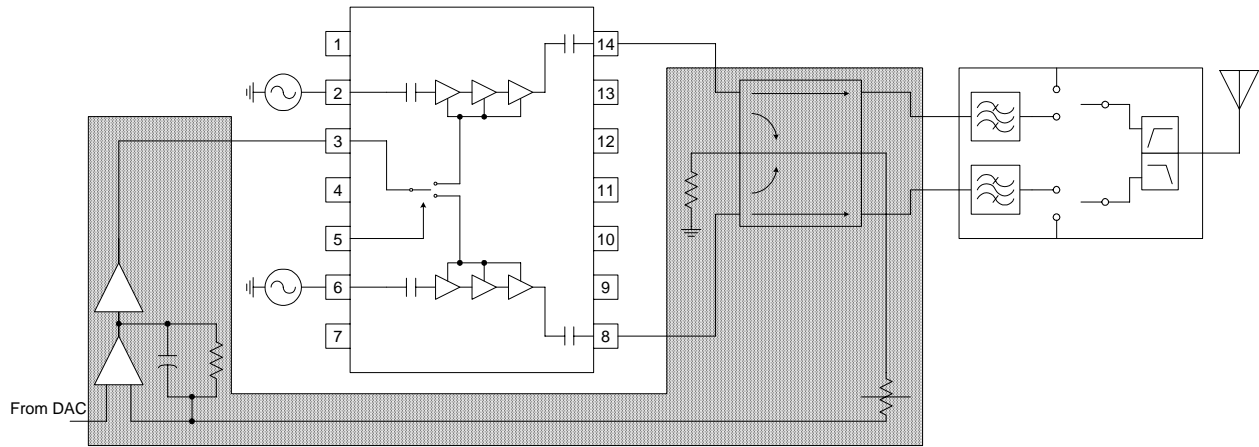

*Shaded area eliminated with Indirect Closed Loop using RF3110

Evaluation Board Layout Board Size 2.0" x 2.0"

Board Thickness 0.032", Board Material FR-4, Multi-layer

2

POWER AMPLIFIERS

