

R1LP0408C-I Series

Wide Temperature Range Version
4 M SRAM (512-kword × 8-bit)

REJ03C0067-0100Z

Rev. 1.00

Aug.01.2003

Description

The R1LP0408C-I is a 4-Mbit static RAM organized 512-kword × 8-bit. R1LP0408C-I Series has realized higher density, higher performance and low power consumption by employing CMOS process technology (6-transistor memory cell). The R1LP0408C-I Series offers low power standby power dissipation; therefore, it is suitable for battery backup systems. It has packaged in 32-pin SOP, 32-pin TSOP II.

Features

- Single 5 V supply: 5 V ± 10%
- Access time: 55/70 ns (max)
- Power dissipation:
 - Active: 10 mW/MHz (typ)
 - Standby: 4 μW (typ)
- Completely static memory.
 - No clock or timing strobe required
- Equal access and cycle times
- Common data input and output.
 - Three state output
- Directly TTL compatible.
 - All inputs and outputs
- Battery backup operation.
- Operating temperature: -40 to +85°C

R1LP0408C-I Series

Ordering Information

Type No.	Access time	Package
R1LP0408CSP-5SI	55 ns	525-mil 32-pin plastic SOP (32P2M-A)
R1LP0408CSP-7LI	70 ns	
R1LP0408CSB-5SI	55 ns	400-mil 32-pin plastic TSOP II (32P3Y-H)
R1LP0408CSB-7LI	70 ns	
R1LP0408CSC-5SI	55 ns	400-mil 32-pin plastic TSOP II reverse (32P3Y-J)
R1LP0408CSC-7LI	70 ns	

Pin Arrangement

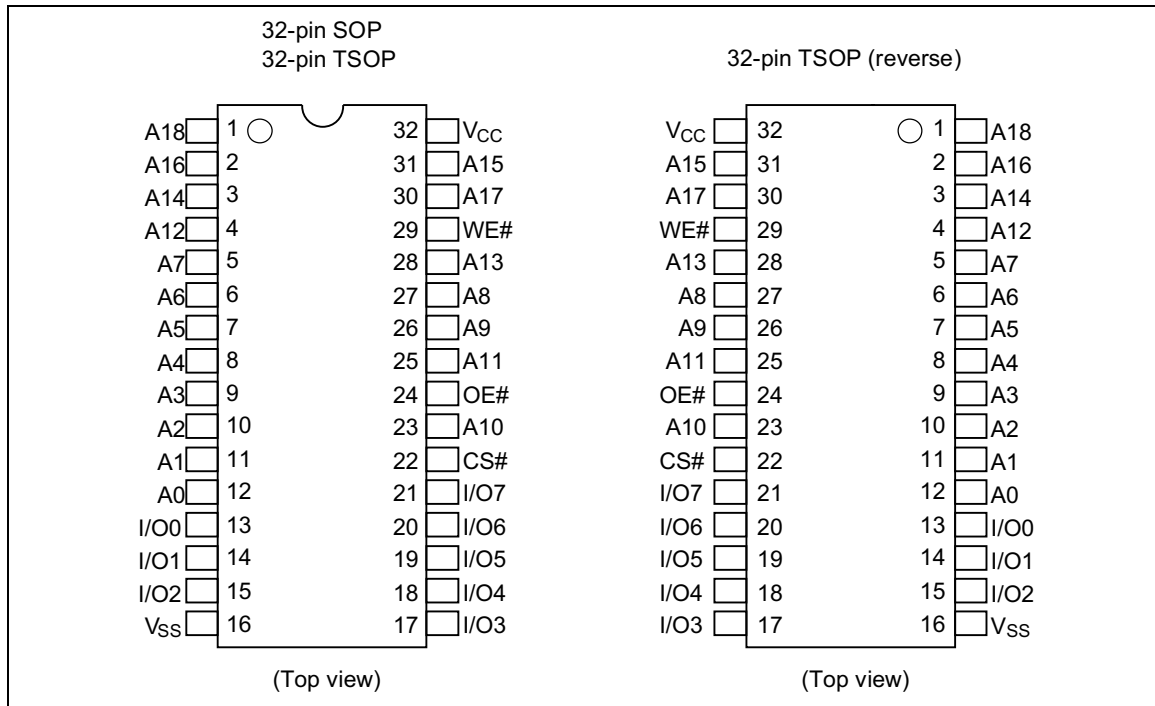

Pin Description

Pin name	Function
A0 to A18	Address input
I/O0 to I/O7	Data input/output
CS# (\overline{CS})	Chip select
OE# (\overline{OE})	Output enable
WE# (\overline{WE})	Write enable
V _{CC}	Power supply
V _{SS}	Ground

Block Diagram

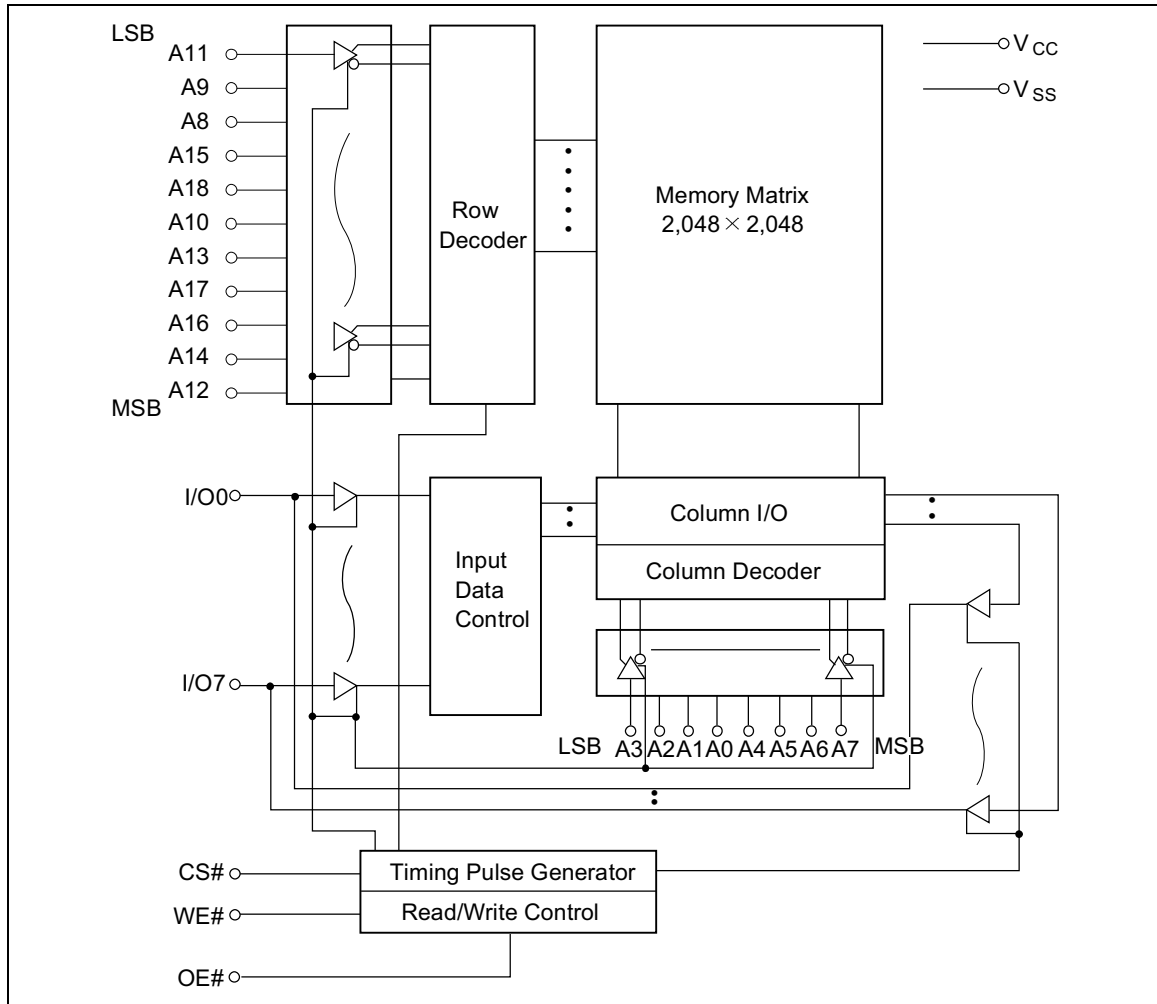

R1LP0408C-I Series

Operation Table

WE#	CS#	OE#	Mode	V _{CC} current	I/O0 to I/O7	Ref. cycle
×	H	×	Not selected	I _{SB} , I _{SB1}	High-Z	—
H	L	H	Output disable	I _{CC}	High-Z	—
H	L	L	Read	I _{CC}	Dout	Read cycle
L	L	H	Write	I _{CC}	Din	Write cycle (1)
L	L	L	Write	I _{CC}	Din	Write cycle (2)

Note: H: V_{IH}, L: V_{IL}, ×: V_{IH} or V_{IL}

Absolute Maximum Ratings

Parameter	Symbol	Value	Unit
Power supply voltage relative to V _{SS}	V _{CC}	−0.5 to +7.0	V
Terminal voltage on any pin relative to V _{SS}	V _T	−0.5* ¹ to V _{CC} + 0.3* ²	V
Power dissipation	P _T	0.7	W
Operating temperature	Topr	−40 to +85	°C
Storage temperature range	Tstg	−65 to +150	°C
Storage temperature range under bias	Tbias	−40 to +85	°C

Notes: 1. V_T min: −3.0 V for pulse half-width ≤ 30 ns.

2. Maximum voltage is +7.0 V.

DC Operating Conditions

(Ta = −40 to +85°C)

Parameter	Symbol	Min	Typ	Max	Unit
Supply voltage	V _{CC}	4.5	5.0	5.5	V
	V _{SS}	0	0	0	V
Input high voltage	V _{IH}	2.2	—	V _{CC} + 0.3	V
Input low voltage	V _{IL}	−0.3* ¹	—	0.8	V

Note: 1. V_{IL} min: −3.0 V for pulse half-width ≤ 30 ns.

R1LP0408C-I Series

DC Characteristics

Parameter	Symbol	Min	Typ* ¹	Max	Unit	Test conditions	
Input leakage current	$ I_{iI} $	—	—	1	μA	$V_{in} = V_{SS}$ to V_{CC}	
Output leakage current	$ I_{Lo} $	—	—	1	μA	CS# = V_{IH} or OE# = V_{IH} or WE# = V_{IL} or $V_{IO} = V_{SS}$ to V_{CC}	
Operating current	I_{CC}	—	1.5	3	mA	CS# = V_{IL} , Others = V_{IH}/V_{IL} , $I_{IO} = 0$ mA	
Average operating current	I_{CC1}	—	8	25	mA	Min. cycle, duty = 100%, CS# = V_{IL} , Others = V_{IH}/V_{IL} , $I_{IO} = 0$ mA	
	I_{CC2}	—	2	5	mA	Cycle time = 1 μs , duty = 100%, $I_{IO} = 0$ mA, CS# ≤ 0.2 V, $V_{IH} \geq V_{CC} - 0.2$ V, $V_{IL} \leq 0.2$ V	
Standby current	I_{SB}	—	0.1	0.5	mA	CS# = V_{IH}	
Standby current	to +85°C	I_{SB1}	—	—	20* ²	μA	$V_{in} \geq 0$ V, CS# $\geq V_{CC} - 0.2$ V
			—	—	10* ³	μA	
	to +40°C	I_{SB1}	—	1.0* ²	10* ²	μA	
			—	1.0* ³	3* ³	μA	
-20°C to +25°C	I_{SB1}	—	0.8* ²	10* ²	μA		
		—	0.8* ³	3* ³	μA		
Output low voltage	V_{OL}	—	—	0.4	V	$I_{OL} = 2.1$ mA	
Output high voltage	V_{OH}	2.4	—	—	V	$I_{OH} = -1.0$ mA	
	V_{OH2}	2.6	—	—	V	$I_{OH} = -0.1$ mA	

Notes: 1. Typical values are at $V_{CC} = 5.0$ V, $T_a = +25^\circ\text{C}$ and specified loading, and not guaranteed.

2. L version. (-7LI)

3. SL version. (-5SI)

Capacitance

($T_a = +25^\circ\text{C}$, $f = 1.0$ MHz)

Parameter	Symbol	Min	Typ	Max	Unit	Test conditions	Note
Input capacitance	C_{in}	—	—	8	pF	$V_{in} = 0$ V	1
Input/output capacitance	$C_{i/O}$	—	—	10	pF	$V_{i/O} = 0$ V	1

Note: 1. This parameter is sampled and not 100% tested.

R1LP0408C-I Series

AC Characteristics

($T_a = -40$ to $+85^\circ\text{C}$, $V_{CC} = 5\text{ V} \pm 10\%$, unless otherwise noted.)

Test Conditions

- Input pulse levels: $V_{IL} = 0.4\text{ V}$, $V_{IH} = 2.4\text{ V}$
- Input rise and fall time: 5 ns
- Input and output timing reference levels: 1.5 V
- Output load: 1 TTL Gate + C_L (50 pF) (R1LP0408C-5I)
1 TTL Gate + C_L (100 pF) (R1LP0408C-7I)
(Including scope and jig)

Read Cycle

Parameter	Symbol	R1LP0408C-I				Unit	Notes
		-5		-7			
		Min	Max	Min	Max		
Read cycle time	t_{RC}	55	—	70	—	ns	
Address access time	t_{AA}	—	55	—	70	ns	
Chip select access time	t_{CO}	—	55	—	70	ns	
Output enable to output valid	t_{OE}	—	25	—	35	ns	
Chip select to output in low-Z	t_{LZ}	10	—	10	—	ns	2
Output enable to output in low-Z	t_{OLZ}	5	—	5	—	ns	2
Chip deselect to output in high-Z	t_{HZ}	0	20	0	25	ns	1, 2
Output disable to output in high-Z	t_{OHZ}	0	20	0	25	ns	1, 2
Output hold from address change	t_{OH}	10	—	10	—	ns	

R1LP0408C-I Series

Write Cycle

Parameter	Symbol	R1LP0408C-I				Unit	Notes
		-5		-7			
		Min	Max	Min	Max		
Write cycle time	t_{WC}	55	—	70	—	ns	
Chip selection to end of write	t_{CW}	50	—	60	—	ns	4
Address setup time	t_{AS}	0	—	0	—	ns	5
Address valid to end of write	t_{AW}	50	—	60	—	ns	
Write pulse width	t_{WP}	40	—	50	—	ns	3, 12
Write recovery time	t_{WR}	0	—	0	—	ns	6
Write to output in high-Z	t_{WHZ}	0	20	0	25	ns	1, 2, 7
Data to write time overlap	t_{DW}	25	—	30	—	ns	
Data hold from write time	t_{DH}	0	—	0	—	ns	
Output active from end of write	t_{OW}	5	—	5	—	ns	2
Output disable to output in high-Z	t_{OHZ}	0	20	0	25	ns	1, 2, 7

- Notes:
- t_{HZ} , t_{OHZ} and t_{WHZ} are defined as the time at which the outputs achieve the open circuit conditions and are not referred to output voltage levels.
 - This parameter is sampled and not 100% tested.
 - A write occurs during the overlap (t_{WP}) of a low CS# and a low WE#. A write begins at the later transition of CS# going low or WE# going low. A write ends at the earlier transition of CS# going high or WE# going high. t_{WP} is measured from the beginning of write to the end of write.
 - t_{CW} is measured from CS# going low to the end of write.
 - t_{AS} is measured from the address valid to the beginning of write.
 - t_{WR} is measured from the earlier of WE# or CS# going high to the end of write cycle.
 - During this period, I/O pins are in the output state so that the input signals of the opposite phase to the outputs must not be applied.
 - If the CS# low transition occurs simultaneously with the WE# low transition or after the WE# transition, the output remain in a high impedance state.
 - Dout is the same phase of the write data of this write cycle.
 - Dout is the read data of next address.
 - If CS# is low during this period, I/O pins are in the output state. Therefore, the input signals of the opposite phase to the outputs must not be applied to them.
 - In the write cycle with OE# low fixed, t_{WP} must satisfy the following equation to avoid a problem of data bus contention. $t_{WP} \geq t_{DW} \text{ min} + t_{WHZ} \text{ max}$

Timing Waveform

Read Timing Waveform (WE# = V_{IH})

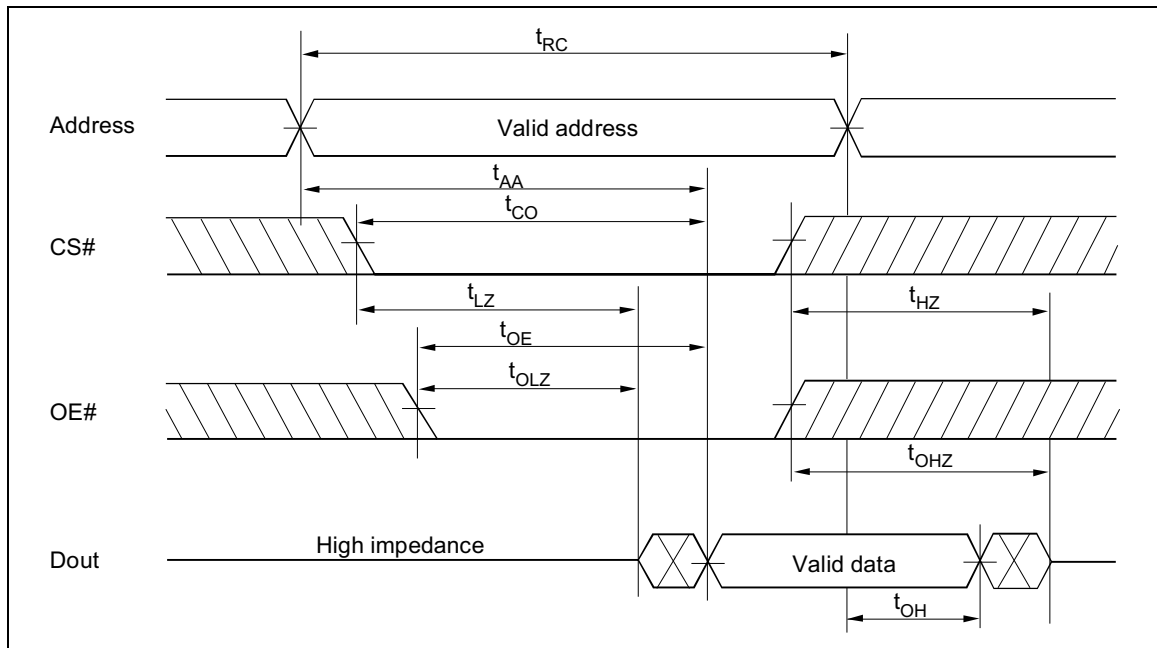

Write Timing Waveform (1) (OE# Clock)

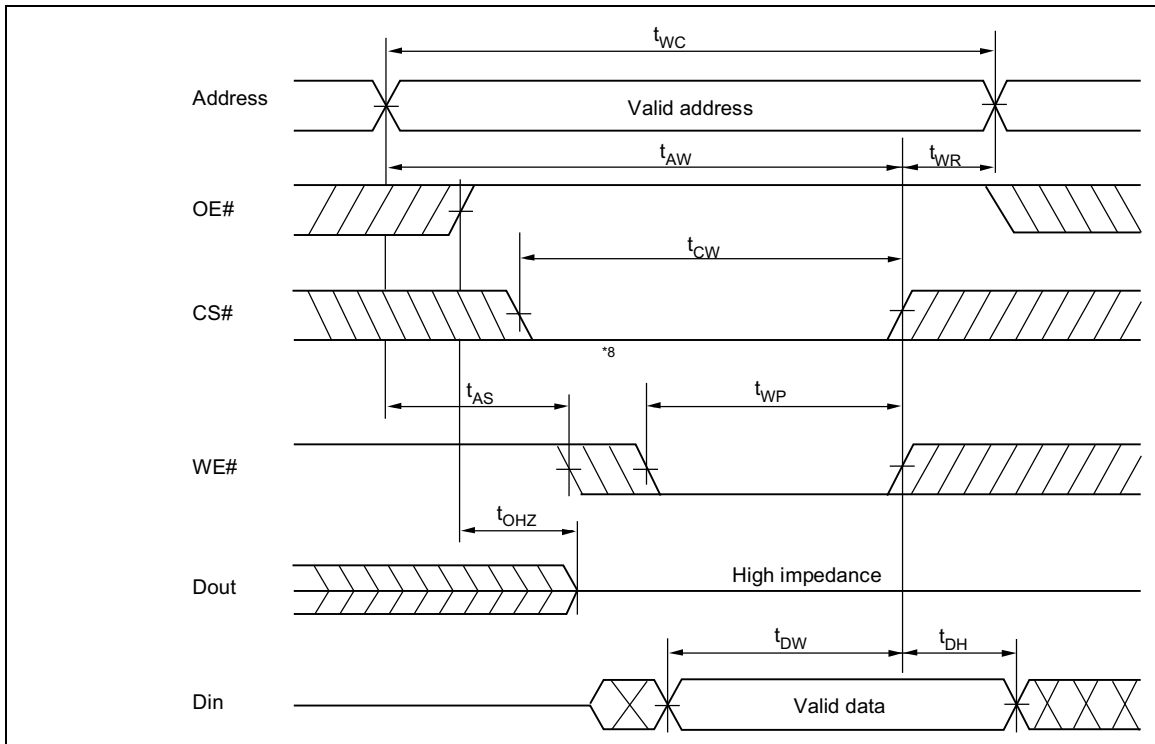

Write Timing Waveform (2) (OE# Low Fixed)

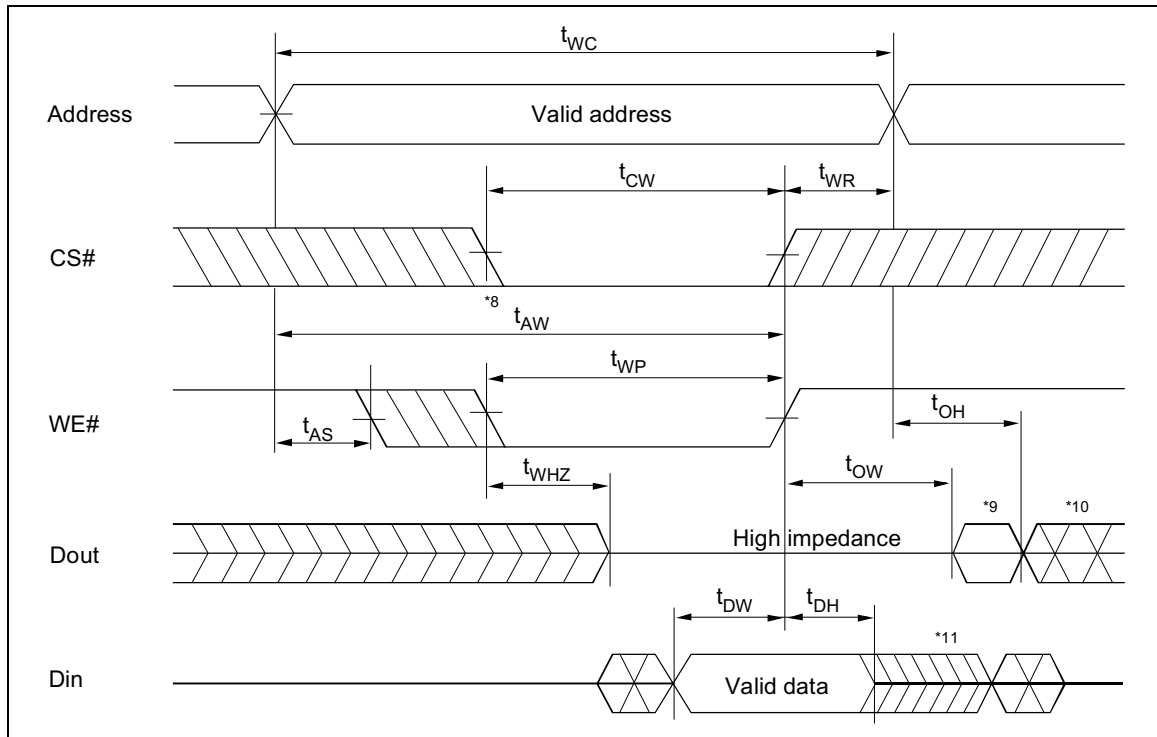

R1LP0408C-I Series

Low V_{CC} Data Retention Characteristics

($T_a = -40$ to $+85^\circ\text{C}$)

Parameter	Symbol	Min	Typ ^{*4}	Max	Unit	Test conditions ^{*3}	
V_{CC} for data retention	V_{DR}	2	—	—	V	$CS\# \geq V_{CC} - 0.2\text{ V}$, $V_{in} \geq 0\text{ V}$	
Data retention current	to $+85^\circ\text{C}$	I_{CCDR}^{*1}	—	—	20	μA	$V_{CC} = 3.0\text{ V}$, $V_{in} \geq 0\text{ V}$ $CS\# \geq V_{CC} - 0.2\text{ V}$
		I_{CCDR}^{*2}	—	—	10		
	to $+40^\circ\text{C}$	I_{CCDR}^{*1}	—	1.0	10	μA	
		I_{CCDR}^{*2}	—	1.0	3		
	-20°C to $+25^\circ\text{C}$	I_{CCDR}^{*1}	—	0.8	10	μA	
		I_{CCDR}^{*2}	—	0.8	3		
Chip deselect to data retention time	t_{CDR}	0	—	—	ns	See retention waveform	
Operation recovery time	t_R	t_{RC}^{*5}	—	—	ns		

- Notes:
1. This characteristic is guaranteed only for L version.
 2. This characteristic is guaranteed only for SL version.
 3. CS# controls address buffer, WE# buffer, OE# buffer, and Din buffer. In data retention mode, Vin levels (address, WE#, OE#, I/O) can be in the high impedance state.
 4. Typical values are at $V_{CC} = 3.0\text{ V}$, $T_a = +25^\circ\text{C}$ and specified loading, and not guaranteed.
 5. t_{RC} = read cycle time.

Low V_{CC} Data Retention Timing Waveform (CS# Controlled)

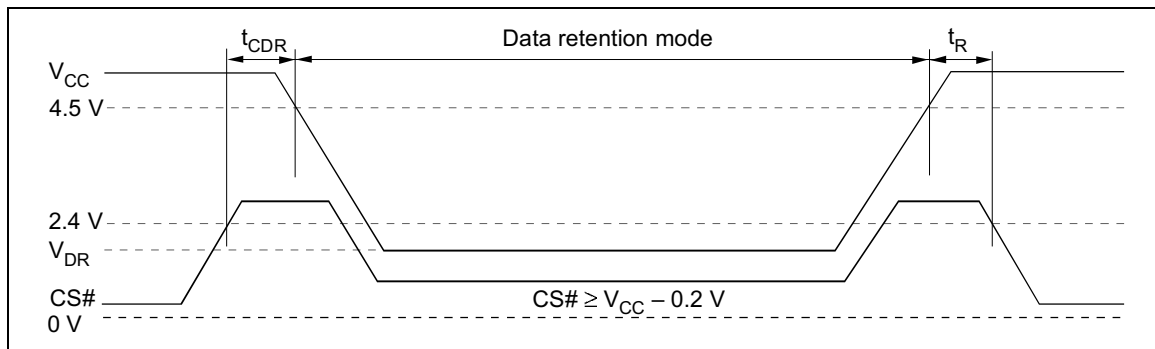

Renesas Technology Corp. Sales Strategic Planning Div. Nippon Bldg., 2-6-2, Ohte-machi, Chiyoda-ku, Tokyo 100-0004, Japan

Keep safety first in your circuit designs!

1. Renesas Technology Corporation puts the maximum effort into making semiconductor products better and more reliable, but there is always the possibility that trouble may occur with them. Trouble with semiconductors may lead to personal injury, fire or property damage.
Remember to give due consideration to safety when making your circuit designs, with appropriate measures such as (i) placement of substitutive, auxiliary circuits, (ii) use of nonflammable material or (iii) prevention against any malfunction or mishap.

Notes regarding these materials

1. These materials are intended as a reference to assist our customers in the selection of the Renesas Technology Corporation product best suited to the customer's application; they do not convey any license under any intellectual property rights, or any other rights, belonging to Renesas Technology Corporation or a third party.
 2. Renesas Technology Corporation assumes no responsibility for any damage, or infringement of any third-party's rights, originating in the use of any product data, diagrams, charts, programs, algorithms, or circuit application examples contained in these materials.
 3. All information contained in these materials, including product data, diagrams, charts, programs and algorithms represents information on products at the time of publication of these materials, and are subject to change by Renesas Technology Corporation without notice due to product improvements or other reasons. It is therefore recommended that customers contact Renesas Technology Corporation or an authorized Renesas Technology Corporation product distributor for the latest product information before purchasing a product listed herein.
The information described here may contain technical inaccuracies or typographical errors.
Renesas Technology Corporation assumes no responsibility for any damage, liability, or other loss rising from these inaccuracies or errors.
Please also pay attention to information published by Renesas Technology Corporation by various means, including the Renesas Technology Corporation Semiconductor home page (<http://www.renesas.com>).
 4. When using any or all of the information contained in these materials, including product data, diagrams, charts, programs, and algorithms, please be sure to evaluate all information as a total system before making a final decision on the applicability of the information and products. Renesas Technology Corporation assumes no responsibility for any damage, liability or other loss resulting from the information contained herein.
 5. Renesas Technology Corporation semiconductors are not designed or manufactured for use in a device or system that is used under circumstances in which human life is potentially at stake. Please contact Renesas Technology Corporation or an authorized Renesas Technology Corporation product distributor when considering the use of a product contained herein for any specific purposes, such as apparatus or systems for transportation, vehicular, medical, aerospace, nuclear, or undersea repeater use.
 6. The prior written approval of Renesas Technology Corporation is necessary to reprint or reproduce in whole or in part these materials.
 7. If these products or technologies are subject to the Japanese export control restrictions, they must be exported under a license from the Japanese government and cannot be imported into a country other than the approved destination.
Any diversion or reexport contrary to the export control laws and regulations of Japan and/or the country of destination is prohibited.
 8. Please contact Renesas Technology Corporation for further details on these materials or the products contained therein.
-

RENESAS

<http://www.renesas.com>

Copyright © 2003. Renesas Technology Corporation, All rights reserved. Printed in Japan.
Colophon 0.0

R1LP0408C-I Series

Revision Record

Rev.	Date	Contents of Modification	Drawn by	Approved by
1.00	Aug. 01, 2003	Initial issue		
